

**REPAIR PARTS MANUAL**  
**MODEL NO. 290042**  
**850 Series 17 Inch**  
**Tiller**

---

**CRAFTSMAN<sup>®</sup>**

# TILLER - - MODEL NUMBER 917.290042

## HANDLES

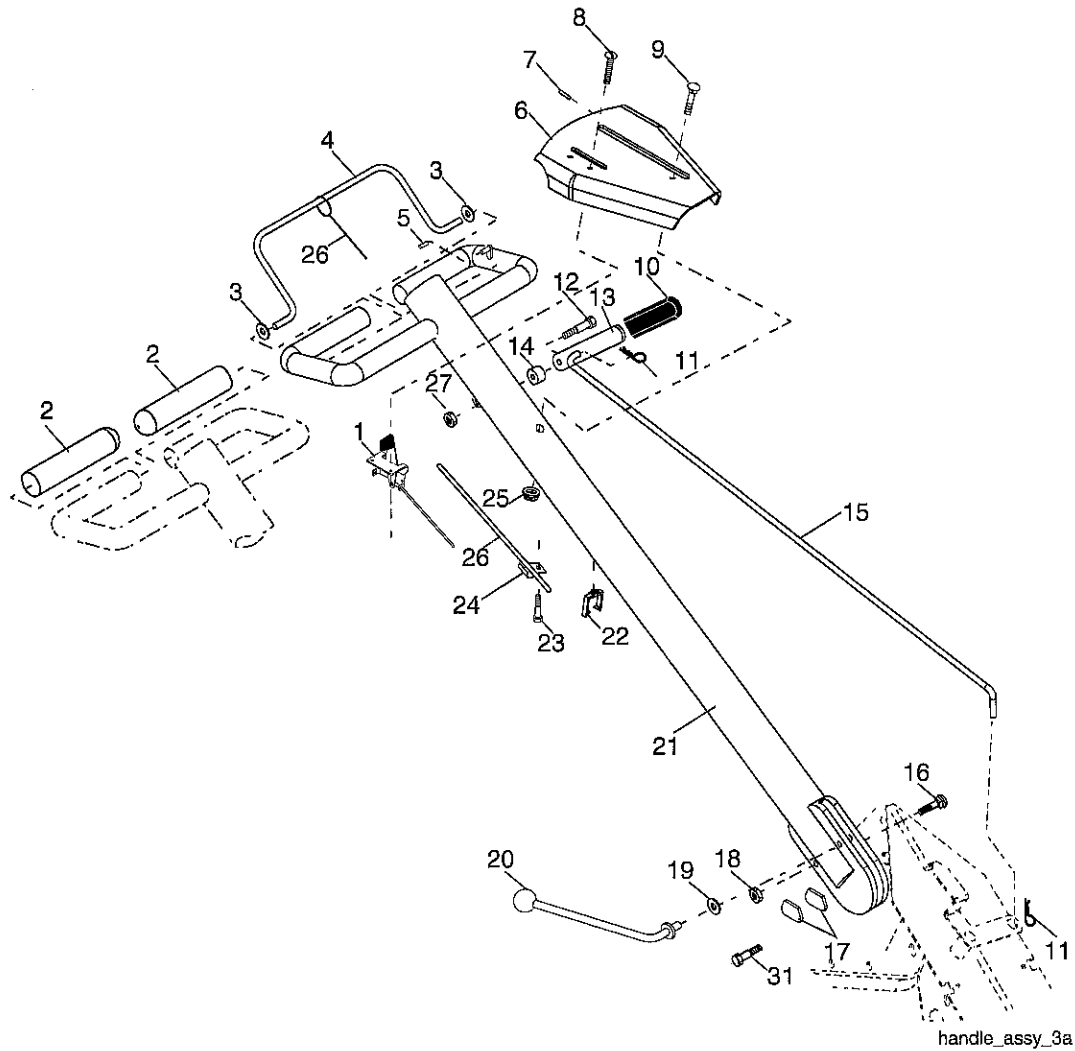

KEY NO.	PART NO.	DESCRIPTION
1	189482	Throttle, Control
2	141406	Grip, Handle
3	110673X	Grommet, Handle
4	127254X	Bar, Drive Control Assembly
5	6712J	Cap, Vinyl
6	188403	Panel, Control
7	110641X	Bushing, Split
8	17720408	Screw 1/4-20 x 1/2
9	72010520	Bolt, 5/16-18 x 2-1/2
10	110646X	Handle, Grip
11	STD624004	Retainer Spring
12	81328	Bolt, Shoulder
13	187497	Handle, Shift
14	109313X	Grommet, Rubber
15	110702X	Rod, Shift
16	STD533710	Bolt, Rdhd Sqnk 3/8-16 x 1 Gr. 5
17	109229X	Lock, Handle

KEY NO.	PART NO.	DESCRIPTION
18	STD541437	Nut, Crownlock 3/8-16
19	19131611	Washer 13/32 x 1 x 11 Ga.
20	109228X	Lever, Lock, Handle
21	420524	Handle, Assemble
22	165197	Clip, Plastic, Cable
23	86777	Screw, Hex, Washer Hd, Slotted #10-24 x 1/2
24	9484R	Clip
25	73970500	Locknut, Hex, Flange
26	110675X	Clutch, Cable
27	73900400	Nut, Hex Flange 1/4-20 unc
31	150696	Bolt, Pivot

**NOTE:** All component dimensions given in U.S. inches.  
1 inch = 25.4 mm

# TILLER - - MODEL NUMBER 917.290042

## MAINFRAME, LEFT SIDE

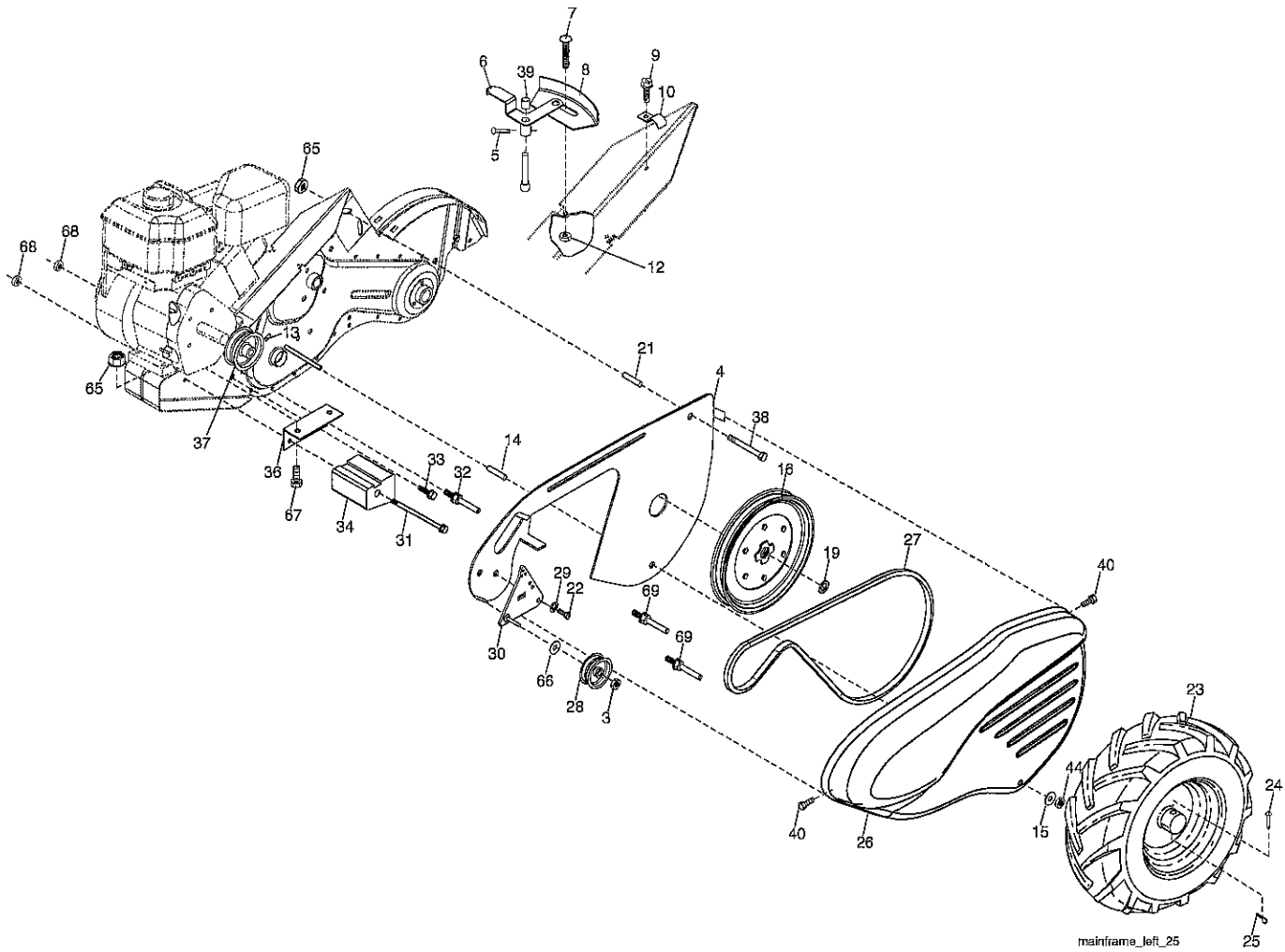

mainframe\_left\_25

KEY NO.	PART NO.	DESCRIPTION	KEY NO.	PART NO.	DESCRIPTION
3	STD541037	Nut, Hex 3/8-16	27	132801	Belt, V
4	432420	Shield, Inner Belt Guard	28	104679X	Pulley, Idler
5	164329	Pin, Shift Lever	29	12000032	Ring, Klip
6	162756	Lever, Shift	30	159229	Bracket, Idler
7	STD532505	Bolt, Carriage 1/4-20 x 1/2 Gr. 5	31	102384X	Bolt, Hex 5/16-16 x 12
8	161530	Plate, Shift Indicator	32	102141X	Shaft, Idler Arm
9	86777	Screw, Hex, Washer Head, Slotted #10-24 x 1/2	33	STD523710	Bolt, Hex 3/8-16 x 1
10	9484R	Clip	34	102383X	Counterweight, LH
12	73510400	Nut, Keps Hex 1/4-20 unc	36	102331X	Bracket, Reinforcement, LH
13	23230506	Screw, Set, 5/16-18 x 3/8	37	130812	Sheave, Engine
14	110652X	Spacer, Split .327 x .42 x 2.09	38	74760544	Bolt, Fin Hex 5/16-18 x 2-3/4
15	STD551031	Washer 11/32 x 11/16 x 16 Ga.	39	140062	Cap, Plunger
16	145102	Sheave, Transmission	40	170488	Screw Hex Wsh. Slit #10-24 x .50
19	12000028	Ring, Retainer	44	STD541431	Nut, Lock 5/16-18
21	156117	Spacer, Split .327 x .42 x 1.220	65	73970500	Nut, Lock Hex Flange
22	74770508	Bolt, Fin Hex 5/16-24 x 1/2	66	19131312	Washer 13/32 x 13/16 x 12 Ga.
23	102190X	Tire	67	74760524	Bolt 5/16-18 x 1-1/2
	183122X613	Rim	68	73510600	Nut, Keps, Hex 3/8-16 unc
	795R	Tire Valve	69	164173	Keeper Belt Engine
24	126875X	Rivet, Drilled			
25	STD624008	Retainer Spring			
26	165501X428	Guard, Belt			

**NOTE:** All component dimensions given in U.S. inches.  
1 inch = 25.4 mm

# TILLER - - MODEL NUMBER 917.290042

## MAINFRAME, RIGHT SIDE

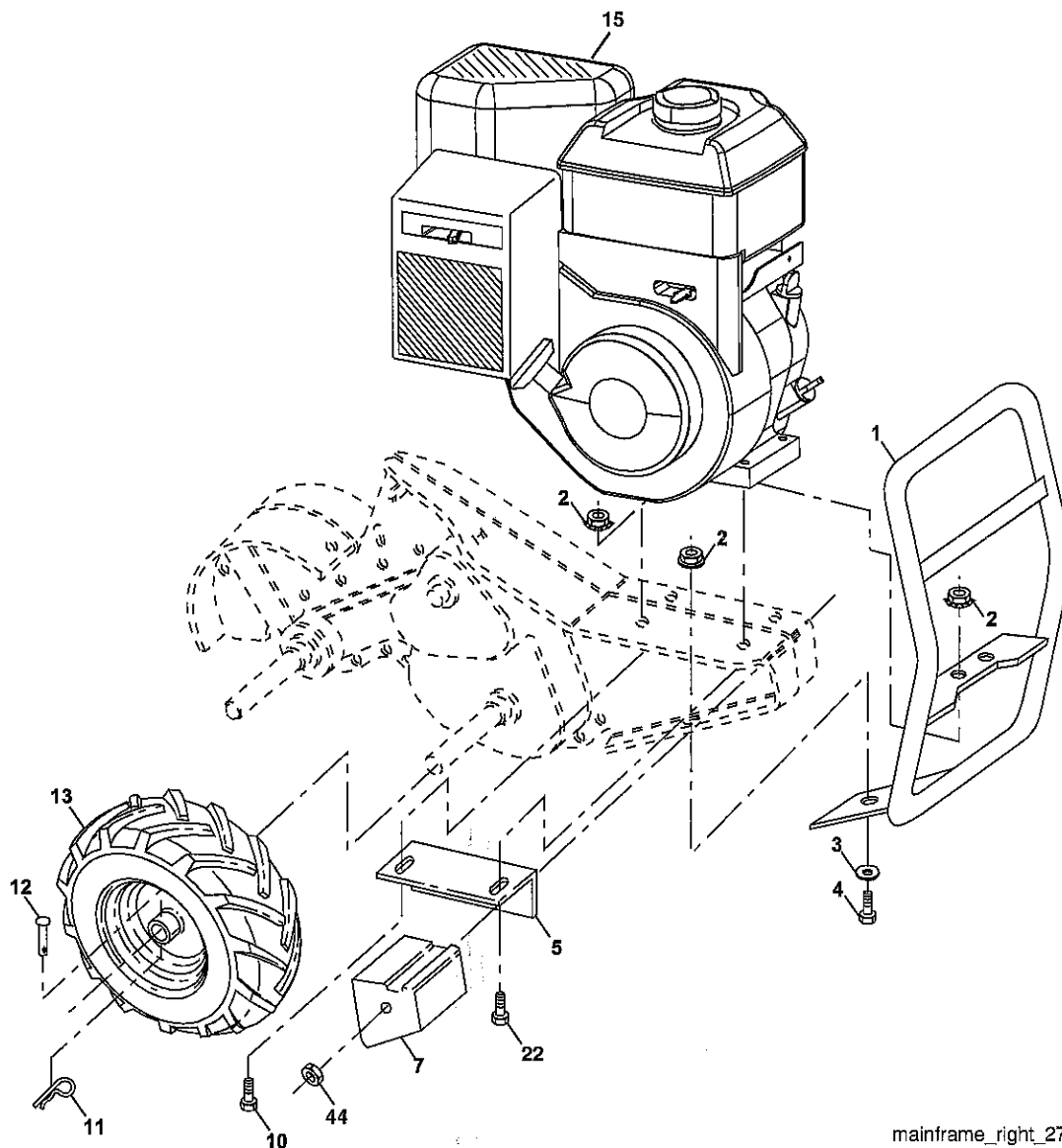

mainframe\_right\_27

KEY NO.	PART NO.	DESCRIPTION
1	185190	Bumper
2	73970500	Locknut, Hex, Flange 5/16-18
3	STD551031	Washer 11/32 x 11/16 x 16, Ga.
4	74760512	Bolt, Hex 5/16-18 x 3/4
5	102332X	Bracket, Reinforcement
7	102173X	Counter Weight, R.H.
10	74760524	Bolt, Hex 5/16-18 x 1-1/2
11	STD624008	Retainer Spring
12	126875X	Rivet, Drilled
13	102190X	Tire

KEY NO.	PART NO.	DESCRIPTION
	183122X613	Rim
	795R	Tire Valve
15	-----	Engine, (See Breakdown) Briggs Model No. 120202-0422-B1
22	74760528	Bolt, Fin Hex 5/16-18 unc x 1-3/4
44	73510600	Nut, Keps, Hex 3/8-16 unc

**NOTE:** All component dimensions given in U.S.inches.  
1 inch = 25.4 mm

# TILLER - - MODEL NUMBER 917.290042

## TRANSMISSION

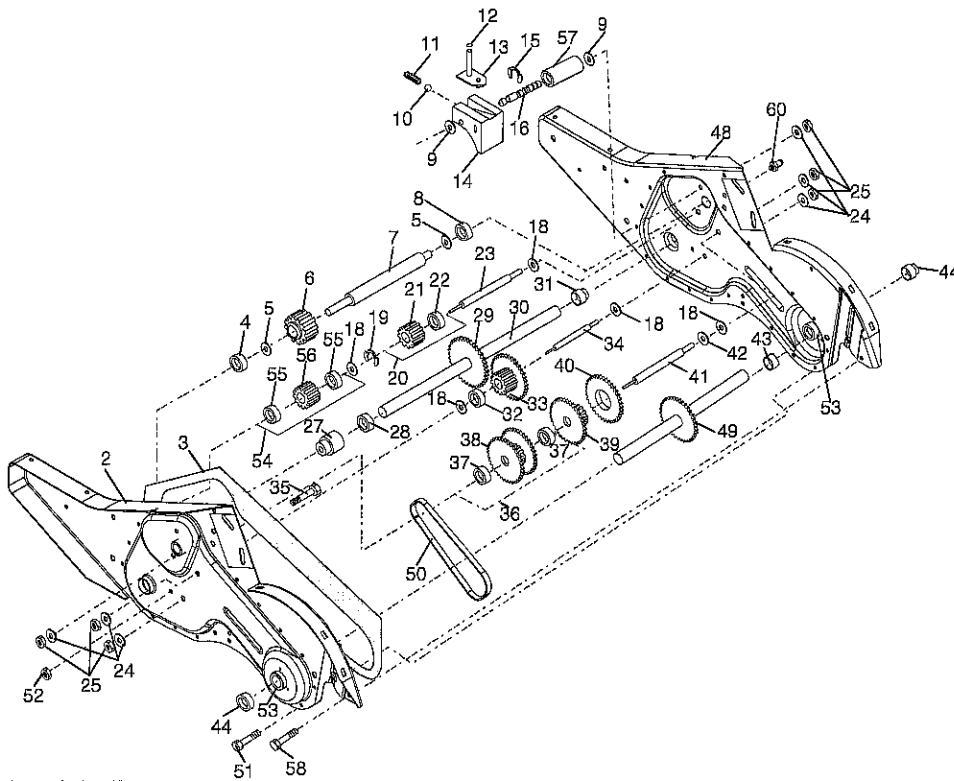

transmission\_7

KEY NO.	PART NO.	DESCRIPTION	KEY NO.	PART NO.	DESCRIPTION
1	188240	Transmission Assembly (Includes Key Nos. 2-52)	32	106388X	Spacer 0.70 x 1.00 x 1.150
2	188220	Gearcase, LH w/Bearing (Includes Key No. 4)	33	102121X	Sprocket and Gear Assembly
3	161963	Gasket, Gearcase	34	102112X	Shaft, Reduction (2nd)
4	5020J	Bearing, Needle	35	102101X	Screw, Whiz, Lock 5/16-18 x 3-1/2
5	1370H	Washer, Thrust 5/8 x 1.10 x 1/32	36	161524	Sprocket Assembly w/Bearing (Includes Key Nos. 37 and 38)
6	161520	Pinion, Input	37	100413K	Bearing, Needle
7	161518	Shaft, Input	38	161525	Sprocket, Tine
8	4895H	Bearing, Needle	39	161526	Gear, Cluster, Red 1st & 2nd
9	154467	Washer, Seal	40	105346X	Gear, Reverse
10	7392M	Ball, Steel	41	161523	Shaft, Reduction (1st)
11	100371K	Spring, Shift, Fork	42	4220R	Washer, Thrust
12	106160X	O-Ring	43	106146X	Spacer 1.01 x 1.75 x 0.760
13	142145	Arm, Shift	44	155236	Seal Asm. Oil
14	8353J	Fork, Shift	48	188235	Gearcase, R.H. w/Bearing (Includes Key No. 8)
15	12000039	Ring, Klip	49	132688	Shaft, Tine
16	161516	Shaft, Shift	50	106147X	Chain, Roller #50-50 Pitch
18	4358J	Washer	51	17720408	Screw 1/4-20 x 1/2
19	12000040	Ring, Klip	52	73220500	Nut, Hex 5/16-18
20	102114X	Gear, Assembly, Reverse Idler (Includes Key Nos. 21 and 22)	53	165140	Bearing Kit, Tine Shaft
21	102115X	Gear, Reverse Idler	54	161528	Gear, DRT Idler w/Bearing (Includes Key No. 55)
22	6803J	Bearing, Needle	55	3400R	Bearing, Needle
23	161527	Shaft, Reverse Idler	56	161529	Gear, DRT Idler
24	STD551143	Washer, Lock 7/16	57	165889	Spacer, Split .52 x .64 x 1.04
25	STD541143	Nut, Hex 7/16-20	58	179520	Screw 1/4-20 x .875
27	143009	Bearing, Shaft, Ground Drive LH	60	183226	Fitting Grease
28	106390X	Spacer 0.765 x 1.125 x 1.23	--	6066J	Grease, Plastilube #1
29	102134X	Chain #35-50 Pitch			
30	150737	Ground Shaft Assembly			
31	143008	Bearing, Shaft, Ground Drive R.H.			

**NOTE:** All component dimensions given in U.S. inches.  
1 inch = 25.4 mm

# TILLER - - MODEL NUMBER 917.290042

## TINE SHIELD

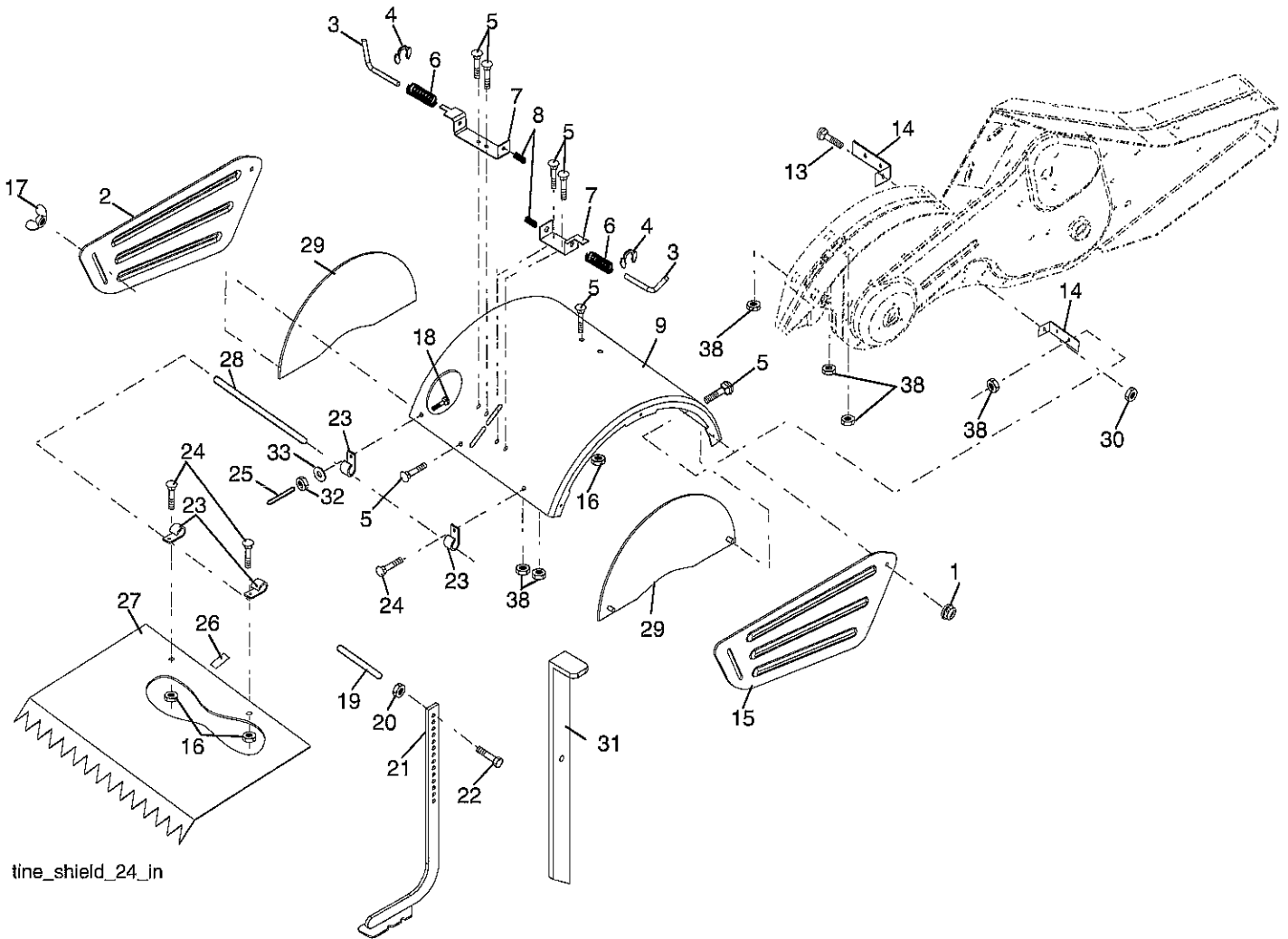

tine\_shield\_24\_in

KEY NO.	PART NO.	DESCRIPTION
1	73900500	Nut, Lock Hex Flange 5/16-18 unc
2	161415X428	Shield, Side, Outer L. H.
3	8393J	Pin, Stake, Depth
4	12000035	Ring, Klip
5	180847	Bolt Rdhd Sqkn 5/16-18 x 3/4
6	8394J	Spring
7	8392J	Bracket, Latch
8	109230X	Spring, Depth Stake
9	188862X428	Shield, Tine
13	72110510	Bolt, Carriage 5/16-18 x 1-1/4
14	124343X	Bracket, Shield Tine
15	161414X428	Shield, Side, Outer R.H.
16	73900400	Nut, Hex Flange 1/4-20
17	162175	Nut, Wing Forged 5/16-18
18	STD532512	Bolt, Carriage 1/4-20 x 1-1/4
19	102701X	Grip
20	STD541037	Nut, Hex 3/8-16
21	102156X	Stake, Depth

KEY NO.	PART NO.	DESCRIPTION
22	74930632	Bolt, Hex 3/8-16 x 2
23	4440J	Hinge
24	72140404	Bolt, Carriage 1/4-20 x 1/2
25	6712J	Cap, Vinyl
26	109227X	Pad, Idler
27	102695X428	Shield, Leveling
28	120588X	Pin, Hinge
29	197761X428	Shield, Side
30	73970500	Nut Lock Hex Flange
31	163498X613	Stake, Drag
32	73220400	Nut, Fin, Hex 1/4-20 unc
33	STD551125	Washer Lock Hvy Helical 1/4
38	73510500	Nut, Keps 5/16-18 unc

**NOTE:** All component dimensions given in U.S. inches.  
1 inch = 25.4 mm

# TILLER - - MODEL NUMBER 917.290042

## TINE ASSEMBLY

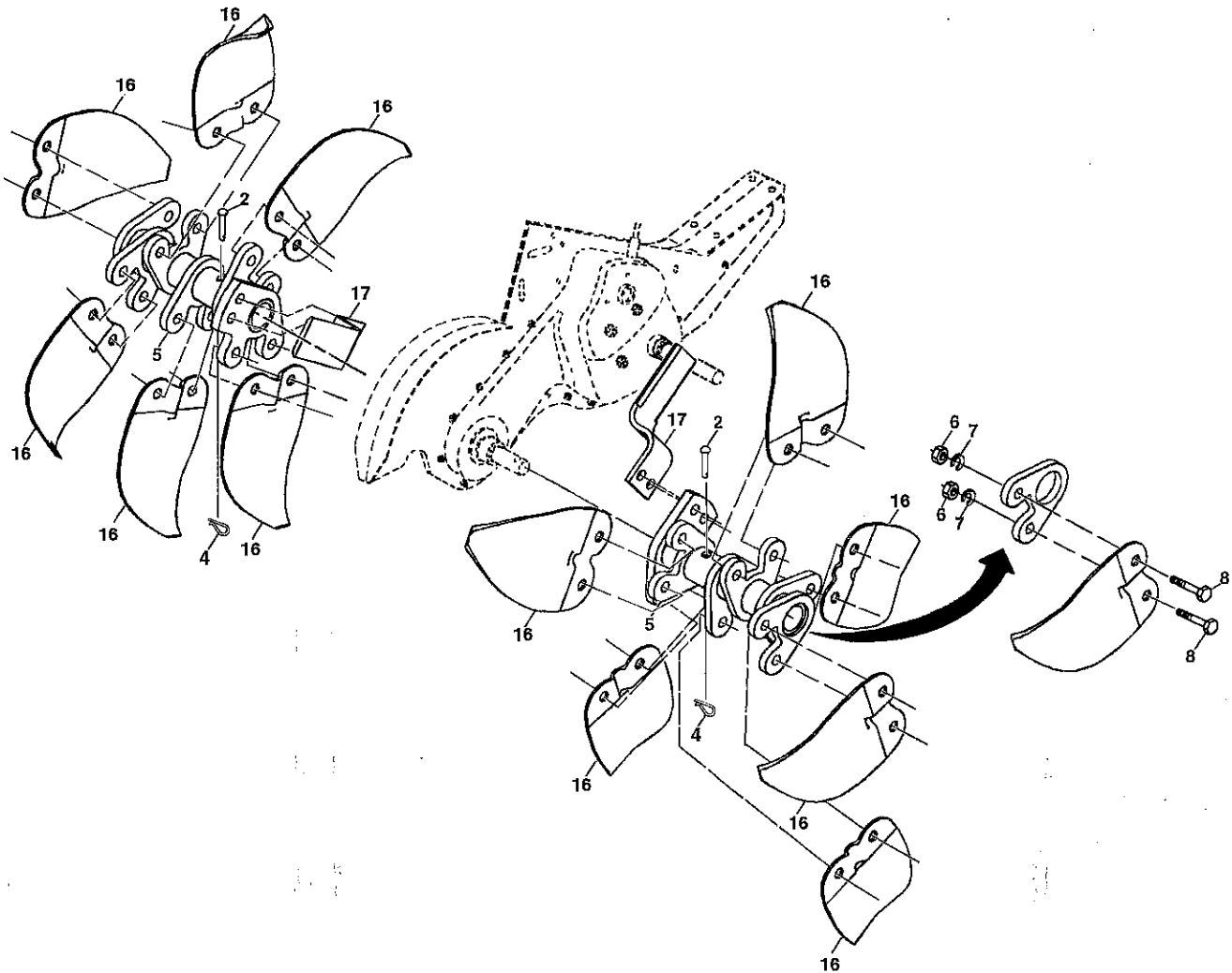

KEY NO.	PART NO.	DESCRIPTION
2	132673	Pin, Shear
4	3146R	Clip, Hairpin
5	188845	Tine Assembly
6	73610600	Nut, Hex 3/8-24
7	STD551137	Washer, Lock 3/8

KEY NO.	PART NO.	DESCRIPTION
8	74610616	Bolt, Hex 3/8-24 x 1
16	163499	Tine, Spade
17	163500	Tine, Cleaning

**NOTE:** All component dimensions given in U.S. inches.  
1 inch = 25.4 mm

# TILLER - - MODEL NUMBER 917.290042

## DECALS

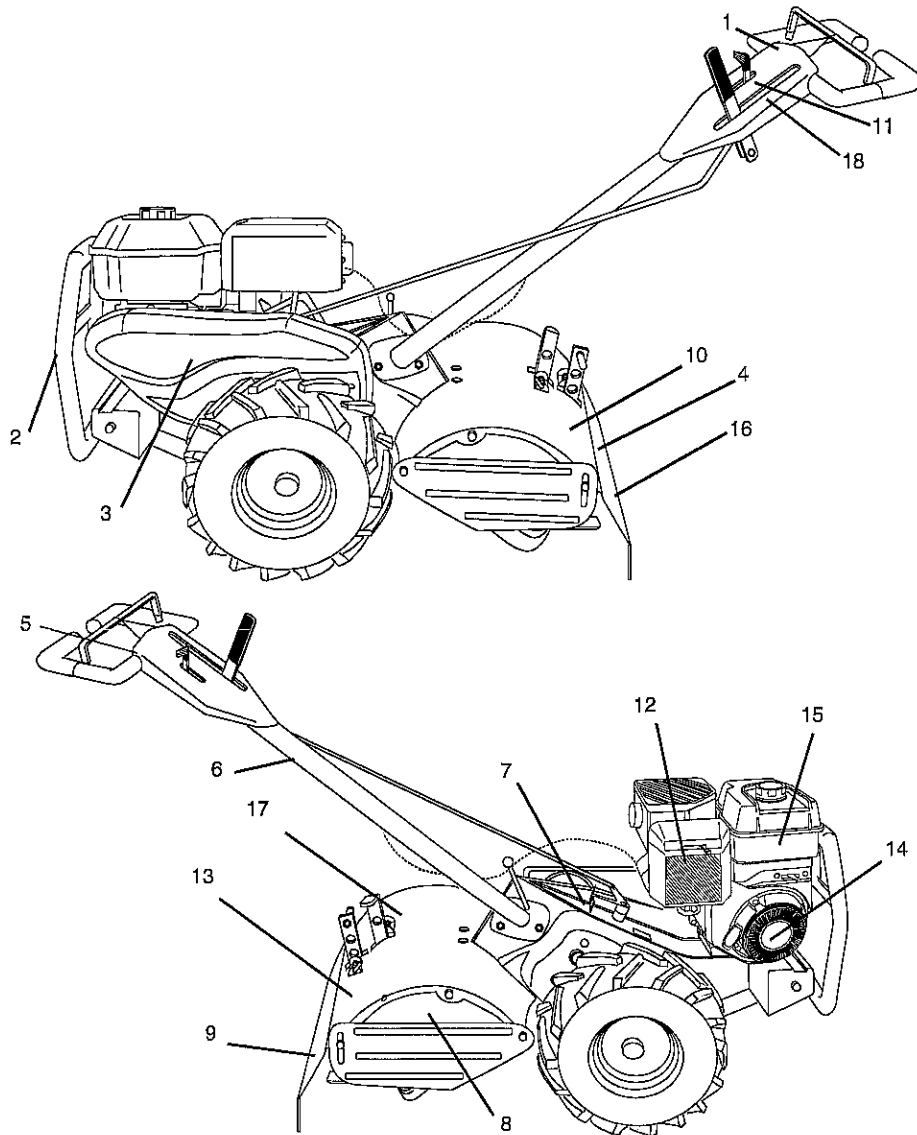

KEY NO.	PART NO.	DESCRIPTION
1	427011	Decal, Console
2	417984	Decal, Logo
3	427008	Decal, Belt Guard
4	196620	Decal, Tine Shield
5	196622	Decal, Caution, Drive Control
6	159877	Decal, Hand Placement
7	196621	Decal, Shift Indicator
8	196638	Decal, Tine, Shield, Counter Rotating Tines
9	176557	Decal, Warning, DRT
10	404460	Decal, Tiller
11	419743	Decal, Console Fast/Stop
12	417554	Decal, BS 850 A/C
13	404462	Decal, Tine Shield
14	411816	Decal, Rewind
15	417682	Decal, OHV
16	145437	Decal, Euro
17	404455	Decal, Tiller
18	420447	Decal, Serv. Console
--	412945	Manual, Operator's (Euro)
--	412946	Manual, Operator's (Scan)
--	426990	Manual, Parts



**TILLER - - MODEL NUMBER 917.290042**  
**ENGINE, BRIGGS & STRATTON -- MODEL NUMBER 120202, TYPE NO. 0422-B1**

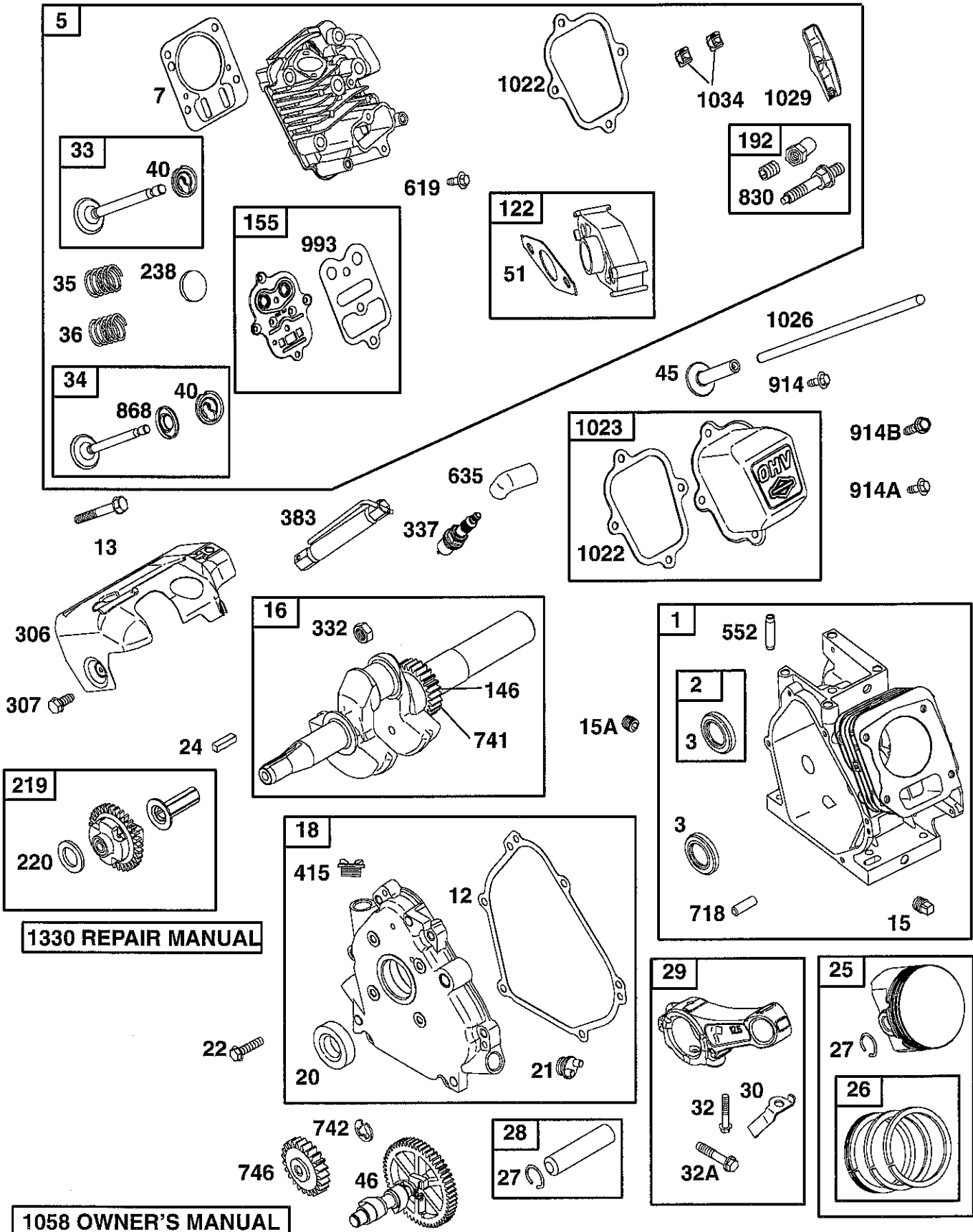

**TILLER -- MODEL NUMBER 917.290042**  
**ENGINE, BRIGGS & STRATTON -- MODEL NUMBER 120202, TYPE NO. 0422-B1**

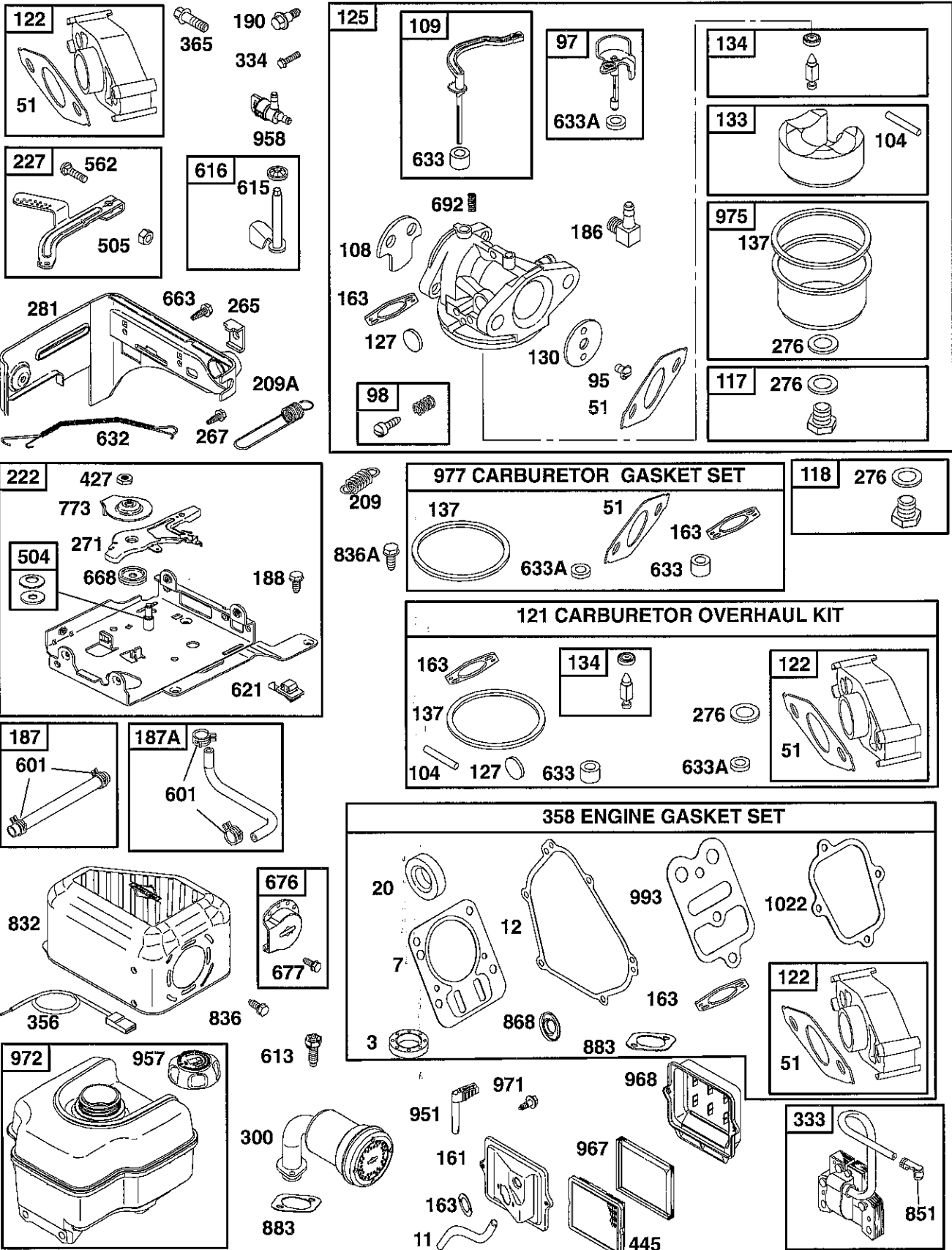

**TILLER - - MODEL NUMBER 917.290042  
ENGINE, BRIGGS & STRATTON -- MODEL NUMBER 120202, TYPE NO. 0422-B1**

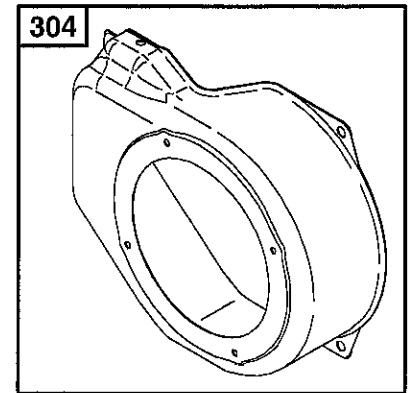
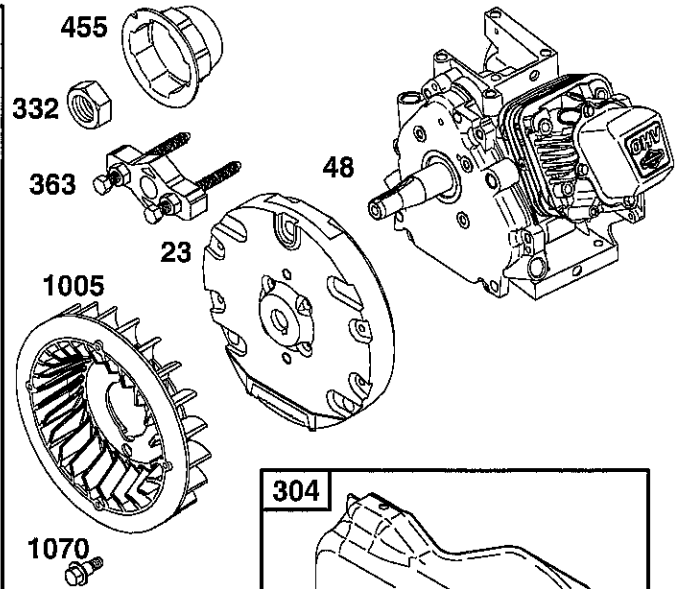
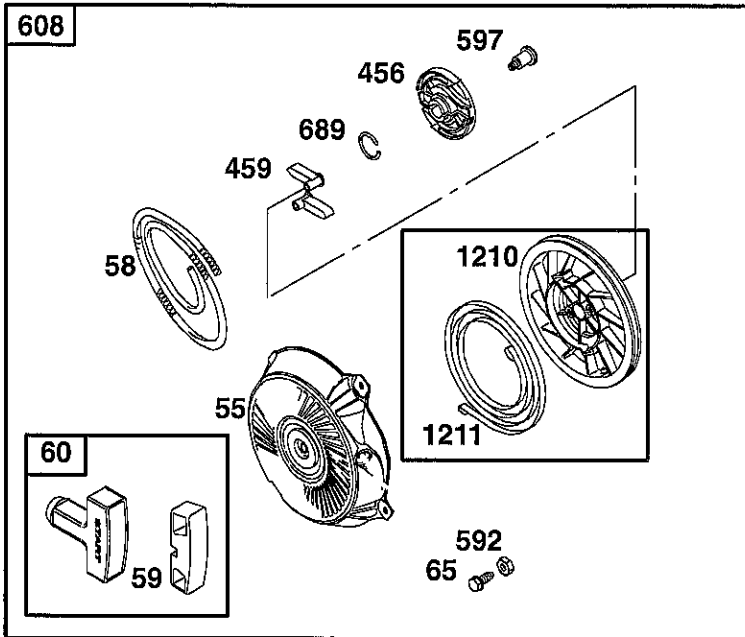

305

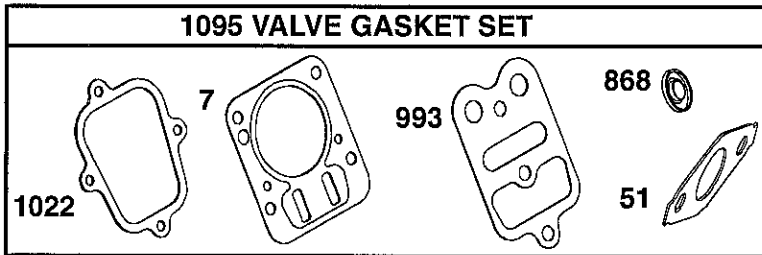

**1036 EMISSIONS LABEL**

**1329 REPLACEMENT ENGINE**

**TILLER - - MODEL NUMBER 917.290042**  
**ENGINE, BRIGGS & STRATTON -- MODEL NUMBER 120202, TYPE NO. 0422-B1**

KEY NO.	PART NO.	DESCRIPTION	KEY NO.	PART NO.	DESCRIPTION
1	699510	Cylinder Assembly	187	791766	Line-Fuel (Cut to Required Length)
2	399269	Kit-Bushing/Seal (Magneto Side)	187A	692601	Line-Fuel (Molded)
3	299819s	• Seal-Oil (Magneto Side)	188	699479	Screw (Control Bracket)
5	699486	Head-Cylinder	190	699220	Screw (Fuel Tank)
7	698210	•+ Gasket-Cylinder Head	192	694543	Adjustor-Rocker Arm
11	790632	Tube-Breather	209	691278	Spring-Governor
12	699485	• Gasket-Crankcase	209A	692571	Spring-Governor
13	699482	Screw (Cylinder Head)	219	693578	Gear-Governor
15	691686	Plug-Oil Drain	220	691724	Washer (Governor Gear)
15A	691682	Plug-Oil Drain	222	699589	Bracket-Control
16	699445	Crankshaft	227	692573	Control Lever-Governor
18	699696	Cover-Crankcase	238	691300	Cap-Valve
20	692550	• Seal-Oil (PTO Side)	265	691024	Clamp-Casing
21	281658s	Cap-Oil Fill	267	699492	Screw (Casing Clamp)
22	699478	Screw (Crankcase Cover/Sump)	271	694256	Lever-Control
23	699488	Flywheel	276	271716	Ø Washer-Sealing
24	222698s	Key-Flywheel	281	699639	Panel-Control
25	791968	Piston Assembly (Standard)	300	693593	Muffler
--	791326	Piston Assembly (.020" Oversize)	304	699598	Housing-Blower
26	791969	Ring Set (Standard)	305	699480	Screw (Blower Housing)
--	791324	Ring Set (.020" Oversize)	306	693610	Shield-Cylinder
27	691866	Lock-Piston Pin	307	699483	Screw (Cylinder Shield)
28	499423	Pin-Piston	332	699359	Nut (Flywheel)
29	690124	Rod-Connecting	333	695711	Armature-Magneto
30	692562	Dipper-Connecting Rod	334	699477	Screw (Armature Magneto)
32	691664	Screw (Connecting Rod)	337	691043	Plug-Spark
32A	695759	Screw (Connecting Rod)	356	692390	Wire-Stop
33	499642	Valve-Exhaust	358	791797	Gasket Set-Engine
34	499641	Valve-Intake	363	19069	Flywheel Puller
35	691304	Spring-Valve (Intake)	365	699484	Screw (Carburetor)
36	691304	Spring-Valve (Exhaust)	383	19374	Wrench-Spark Plug
40	692194	Retainer-Valve	415	693463	Plug
45	690977	Tappet-Valve	427	694255	Nut (Control Bracket)
46	693404	Camshaft	445	491588s	Filter-Air Cleaner Cartridge
48	791518	Short Block	455	692591	Cup-Flywheel
51	692555	• Ø‡+ Gasket-Intake	456	692299	Plate-Pawl Friction
55	691422	Housing-Rewind Starter	459	281505s	Pawl-Ratchet
58	693389	Rope-Starter (Cut to Required Length)	504	694254	Washer Set
59	805957	Insert-Grip	505	691251	Nut (Governor Control Lever)
60	691915	Grip-Starter Rope	552	692346	Bushing-Governor Crank
65	690837	Screw (Rewind Starter)	562	691112	Bolt (Governor Control Lever)
95	691636	Screw (Throttle Valve)	592	690800	Nut (Rewind Starter)
97	690024	Shaft-Throttle	597	691696	Screw (Pawl Friction Plate)
98	398185	Kit-Idle Speed	601	791850	Clamp-Hose
104	691242	Ø Pin-Float Hinge	608	693394	Starter-Rewind
108	692567	Valve-Choke	613	791972	Screw (Muffler)
109	690023	Shaft-Choke	615	692576	Retainer-Governor Shaft
117	498978	Jet-Main (Standard)	616	692547	Crank-Governor
118	498975	Jet-Main (High Altitude)	619	699230	Screw (Cylinder Head Plate)
121	792006	Kit-Carburetor Overhaul	621	692310	Switch-Stop
122	693749	• Ø Spacer-Carburetor	632	693408	Spring/Link-Mechanical Governor
125	696981	Carburetor	633	693867	Ø‡ Seal-Choke/Throttle Shaft
127	691739	Ø Plug-Welch	633A	691321	Ø‡ Seal-Throttle Shaft
130	691181	Valve-Throttle	635	692076	Boot-Spark Plug
133	398187	Float-Carburetor	663	699206	Screw (Control Panel)
134	398188	Ø Kit-Needle/Seat	668	694257	Spacer
137	693981	Ø‡ Gasket-Float Bowl	676	393757	Deflector-Muffler
146	690979	Key-Timing	677	690661	Screw (Muffler Deflector)
155	698214	Plate-Cylinder Head			
161	790631	Base-Air Cleaner			
163	696024	Gasket-Air Cleaner			
186	692317	Connector-Hose			

• Included in Engine Gasket Set, Key. No. 358  
Ø Included in Carburetor Overhaul Kit, Key. No. 121  
‡ Included in Carburetor Gasket Set, Key. No. 977  
+ Included in Valve Gasket Set, Key. No. 1095

**NOTE:** All component dimensions given in U.S. inches 1 inch = 25.4 mm

**TILLER - - MODEL NUMBER 917.290042**  
**ENGINE, BRIGGS & STRATTON -- MODEL NUMBER 120202, TYPE NO. 0422-B1**

KEY NO.	PART NO.	DESCRIPTION
689	691855	Spring-Friction
692	690572	Spring-Detent
718	690959	Pin-Locating
741	695087	Gear-Timing
742	692564	Retainer-E Ring
746	692566	Gear-Idler
773	694258	Retainer
830	694544	Stud-Rocker Arm
832	693583	Guard-Muffler
836	699203	Screw (Muffler Guard)
836A	699632	Screw (Muffler Guard)
851	493880s	Terminal-Spark Plug
868	692044	•+ Seal-Valve
883	691893	•+ Gasket-Exhaust
914	699481	Screw (Rocker Cover) (Bottom)
914A	692557	Screw (Rocker Cover) (Top)
914B	697551	Screw (Rocker Cover) (Center)
951	790630	Lever-Choke
957	694261	Cap-Fuel Tank
958	698180	Valve-Fuel Shut Off
961	698304	Screw (Air Cleaner Bracket)
967	273356s	Filter-Pre Cleaner
968	790633	Cover-Air Cleaner
971	690370	Screw (Air Cleaner Base)
972	694260	Tank-Fuel
975	493640	Bowl-Float
977	697001	Set-Carburetor Gasket
993	694088	•+ Gasket-Cylinder Head Plate
1005	692592	Fan-Flywheel
1022	691890	•+ Gasket-Rocker Cover
1023	499924	Cover-Rocker
1026	790287	Rod-Push
1029	691230	Arm-Rocker
1034	691343	Guide-Push Rod
1036	792814	Label-Emissions
1058	275092	Owner's Manual
1070	699201	Screw (Flywheel Fan)
1095	698215	Gasket Set-Valve
1210	498144	Pulley/Spring Assembly (Pulley)
1211	498144	Pulley/Spring Assembly (Spring)
1329	121A02-0020	Replacement Engine
1330	272147	Repair Manual

- Included in Engine Gasket Set, Key. No. 358
- ∅ Included in Carburetor Overhaul Kit, Key. No. 121
- ‡ Included in Carburetor Gasket Set, Key. No. 977
- + Included in Valve Gasket Set, Key. No. 1095

**NOTE:** All component dimensions given in U.S. inches  
1 inch = 25.4 mm

---

# SERVICE NOTES

---

---

# SERVICE NOTES

---

## LIMITED TWO YEAR WARRANTY ON CRAFTSMAN TILLER

For two years from date of purchase, when this Craftsman Tiller is maintained, lubricated, and tuned up according to the operating and maintenance instructions in the owner's manual, Sears will repair free of charge any defect in material or workmanship.

This Warranty does not cover:

- Expendable items which become worn during normal use, such as tines, spark plugs, air cleaners and belts.
- Repairs necessary because of operator abuse or negligence, including bent crankshafts and the failure to maintain the equipment according to the instructions contained in the owner's manual.
- If this Craftsman Tiller is used for commercial or rental purposes, this Warranty applies for only 30 days from the date of purchase.

WARRANTY SERVICE IS AVAILABLE BY RETURNING THE CRAFTSMAN TILLER TO THE NEAREST SEARS SERVICE CENTER/DEPARTMENT IN THE UNITED STATES. THIS WARRANTY APPLIES ONLY WHILE THIS PRODUCT IS IN USE IN THE UNITED STATES.

This Warranty gives you specific legal rights, and you may also have other rights which vary from state to state.

SEARS, ROEBUCK AND CO., D/817WA, HOFFMAN ESTATES, IL 60179

**CRAFTSMAN®**