



REPAIR PARTS MANUAL

MODEL NO. 293110

6.0 HP 17 Inch

Tiller

CRAFTSMAN®

CRAFTSMAN®

IMPORT

Max & Erik Pedersen
Aabyvej 69, DK-8230 Aabyhøj
Tlf. 8615 4444, Fax 8615 4188

172184 10.26.99 TR
PRINTED IN U.S.A.

REPAIR PARTS

TILLER - - MODEL NUMBER 917.293110

HANDLES

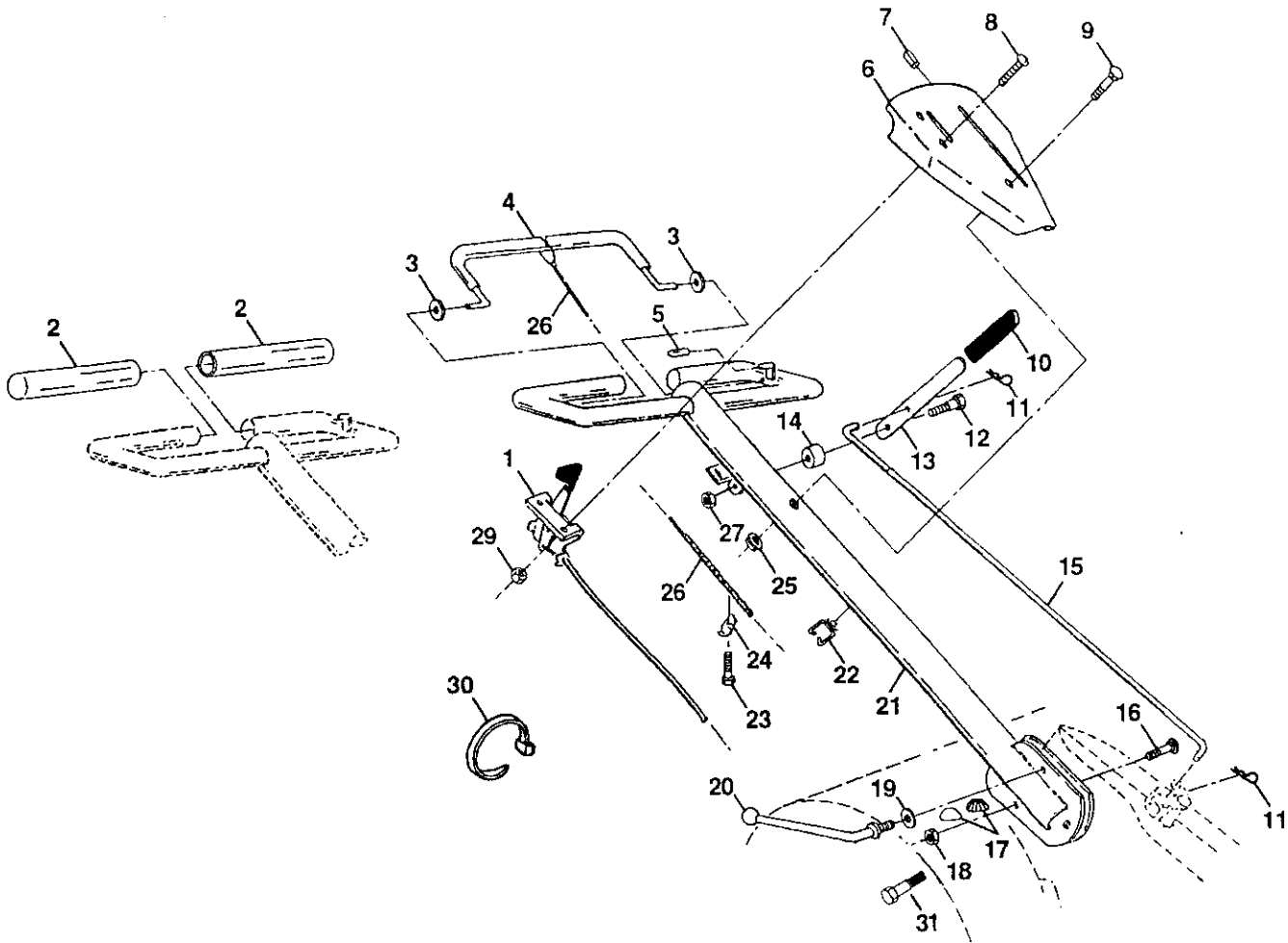

KEY NO.	PART NO.	DESCRIPTION
1	164743	Throttle, Control
2	141406	Grip, Handle
3	110673X	Grommet, Handle
4	127254X	Bar, Assembly Control
5	6712J	Cap, Vinyl
6	137119	Panel, Control
7	110641X	Bushing, Split
8	71191008	* Screw 10-24
9	72010520	* Bolt, 5/16-18 x 2.50
10	110646X	Handle, Grip
11	STD624003	* Clip, Hairpin
12	81328	Bolt, Shoulder
13	110741X	Handle, Shift
14	109313X	Grommet, Rubber
15	110702	Rod, Shift
16	STD533710	* Bolt, Carriage 3/8-16 x 1 Gr. 5
17	109229X	Lock, Handle
18	STD541437	* Nut, Centerlock 3/8-16

KEY NO.	PART NO.	DESCRIPTION
19	19131611	Washer 13/32 x 1 x 11 Ga.
20	109228X	Lever, Lock, Handle
21	150258	Column, Handle, Asm.
22	165197	Clip, Nyl Blk, Cable
23	86777	Screw, Hex, Washer #10-24 x 1/2
24	9484R	Clip
25	73970500	Locknut, Hex, Flange
26	110675X	Clutch, Cable
27	STD541025	* Nut, Fin, Hex 1/4-20
29	STD541462	Nut, Keps #10-24
30	7192J	Tie, Cable
31	150696	Bolt, Pivot

* STANDARD HARDWARE - - PURCHASE
LOCALLY Assembly

NOTE: All component dimensions given in U.S. inches.
1 inch = 25.4 mm

REPAIR PARTS

TILLER - - MODEL NUMBER 917.293110

MAINFRAME, LEFT SIDE

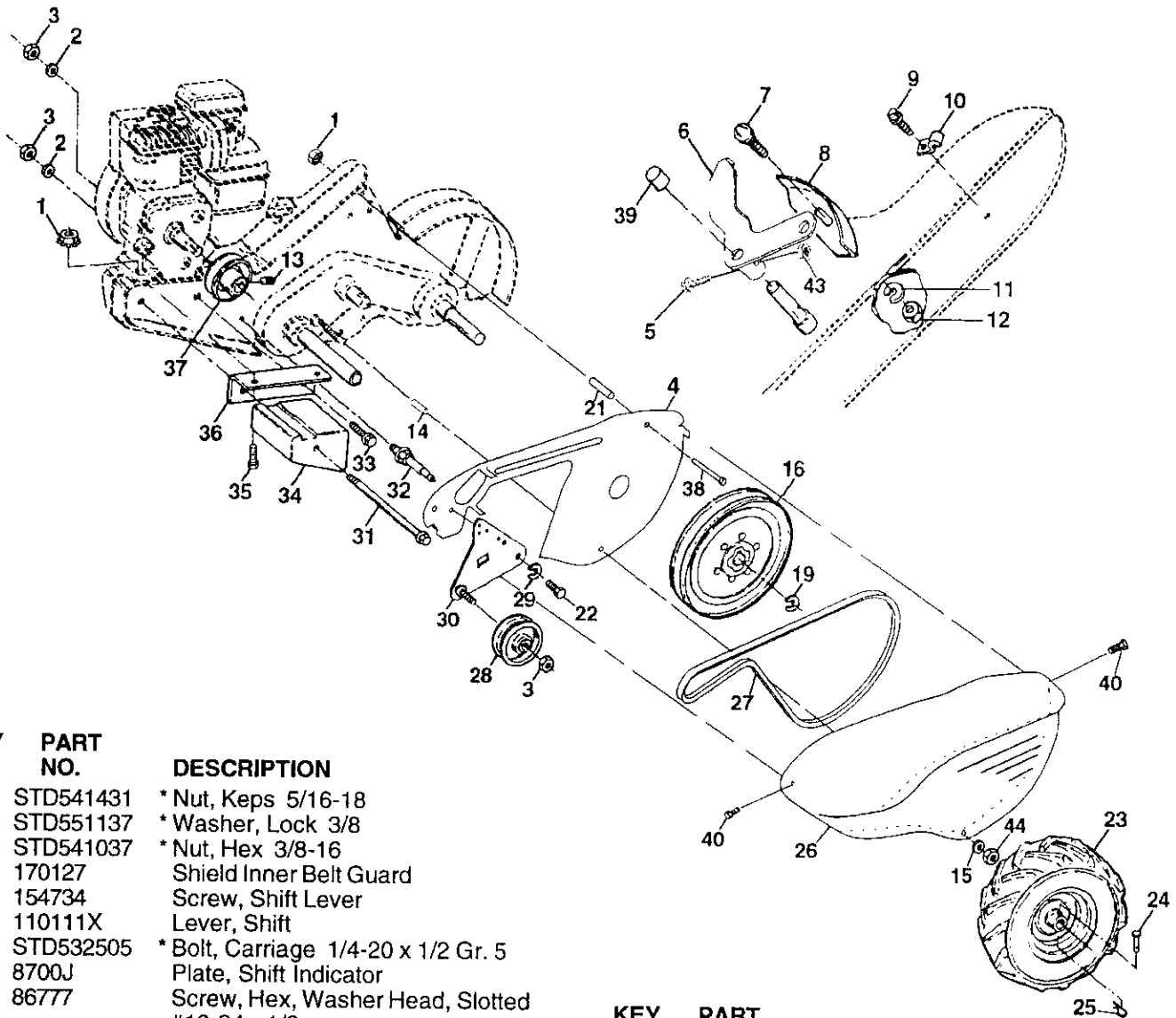

KEY NO.	PART NO.	DESCRIPTION
1	STD541431	* Nut, Keps 5/16-18
2	STD551137	* Washer, Lock 3/8
3	STD541037	* Nut, Hex 3/8-16
4	170127	Shield Inner Belt Guard
5	154734	Screw, Shift Lever
6	110111X	Lever, Shift
7	STD532505	* Bolt, Carriage 1/4-20 x 1/2 Gr. 5
8	8700J	Plate, Shift Indicator
9	86777	Screw, Hex, Washer Head, Slotted #10-24 x 1/2
10	9484R	Clip
11	STD551125	* Washer, Lock 1/4
12	STD541025	* Nut, Hex 1/4-20
13	23230506	* Screw, Set, Hex 5/16-18 x 3/8
14	156117	Spacer, Split 0.327 x 0.42 x 1.220
15	STD551031	* Washer 11/32 x 11/16 x 16 Ga.
16	145102	Sheave, Transmission
19	12000028	Ring, Retainer
21	110652X	Spacer, Split 0.327 x 0.42 x 1.668
22	74770508	Bolt Fin Hex 5/16-24 Unf x 1/2
23	5015J	Tire
	128952	Rim
	795R	Tire Valve
24	126875X	Rivet, Drilled
25	STD624003	* Retainer Spring
26	165501	Guard, Belt
27	132801	Belt, V
28	104679X	Pulley, Idler

KEY NO.	PART NO.	DESCRIPTION
29	12000032	Ring, Klip
30	159229	Bracket, Idler
31	102384X	Bolt, Hex 5/16-16 x 12
32	102141X	Shaft, Idler Arm
33	STD523710	* Bolt, Hex 3/8-16 x 1
34	102383X	Counterweight, L. H.
35	STD523120	Bolt, Hex 5/16-18 x 2
36	102331X	Bracket, Reinforcement, L. H.
37	130812	Sheave, Engine
38	74760544	Bolt Fin Hex 5/16-18 Unc x 2-3/4
39	140062	Cap, Plunger
40	170488	Screw Hex Wsh Slit #10-24 x 50
43	69180	Nut Lock #10-24
44	STD541431	Nut Lock Hx W/Ins 5/16-18 Unc

* STANDARD HARDWARE -- PURCHASE LOCALLY

NOTE: All component dimensions given in U.S. inches.
1 inch = 25.4 mm

REPAIR PARTS

TILLER - - MODEL NUMBER 917.293110

MAINFRAME, RIGHT SIDE

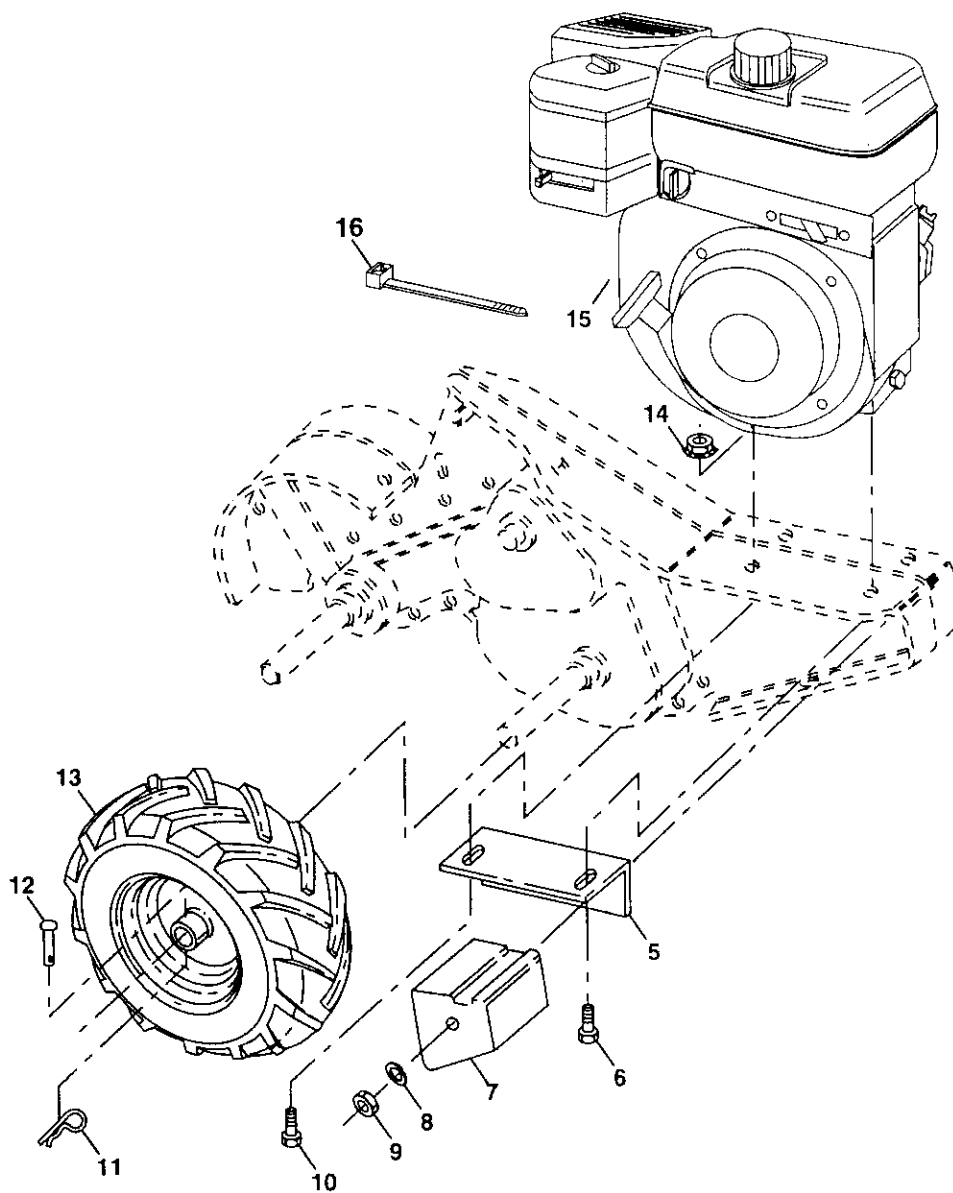

KEY NO.	PART NO.	DESCRIPTION
5	102332X	Bracket, Reinforcement
6	STD523120	Bolt Fin Hex 5/16-18
7	102173X	CounterWeight, R.H.
8	STD551137	* Washer, Lock 3/8
9	STD541037	* Nut, Hex 3/8-16
10	74760524	Bolt, Hex 5/16-18 x 1-1/2
11	STD624003	* Retainer Spring
12	126875X	Rivet, Drilled

KEY NO.	PART NO.	DESCRIPTION
13	5015J	Tire
	128952	Rim
	795R	Tire Valve
15	-----	Engine(See breakdown) Briggs Model 110402-0180-E1
16	7192J	Tie Cable

* STANDARD HARDWARE - - PURCHASE LOCALLY

NOTE: All component dimensions given in U.S.inches.
1 inch = 25.4 mm

REPAIR PARTS

TILLER - - MODEL NUMBER 917.293110

TRANSMISSION

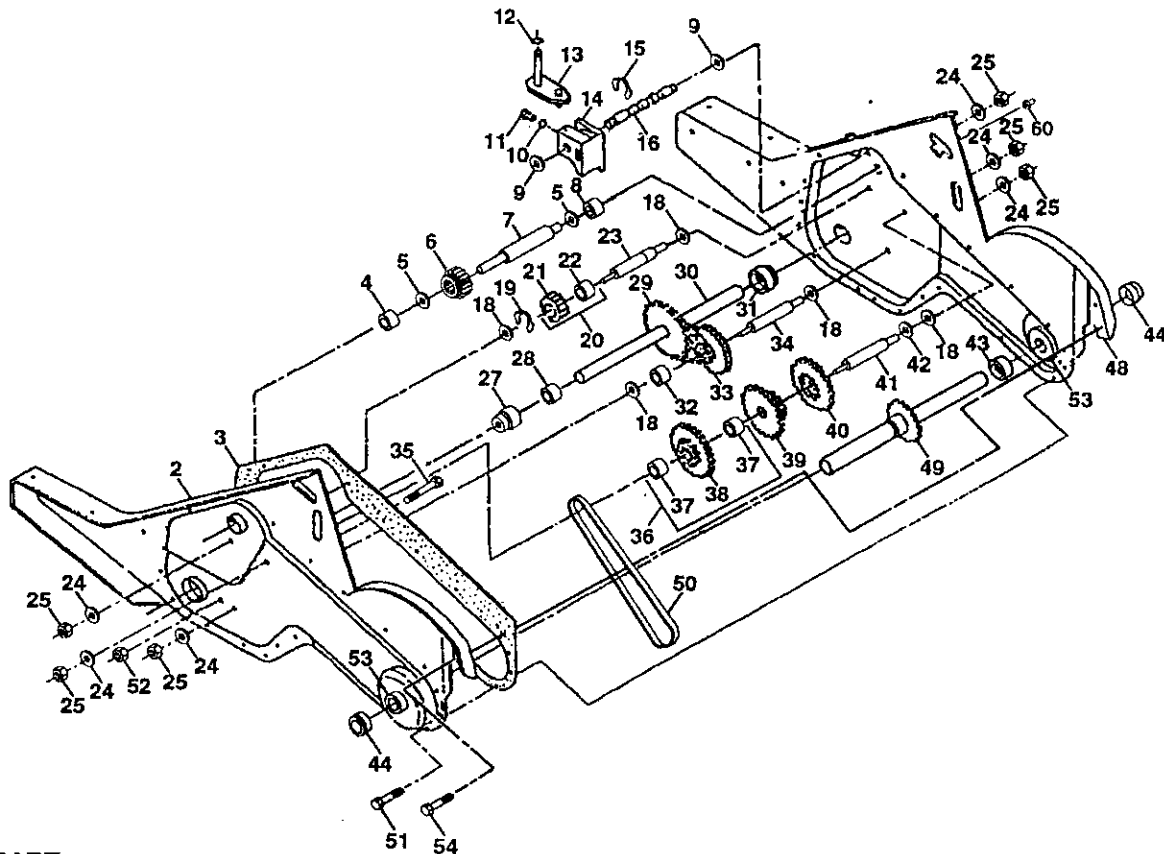

KEY NO.	PART NO.	DESCRIPTION	KEY NO.	PART NO.	DESCRIPTION
1	170337	Transmission Assembly (Includes Key Nos. 2-52)	31	143008	Bearing, Shaft, Ground Drive R.H.
2	165729	Gearcase, L.H. w/Bearing (Includes Key No. 4)	32	106388X	Spacer 0.70 x 1.00 x 1.150
3	161963	Gasket, Gearcase	33	102121X	Sprocket and Gear Assembly
4	5020J	Bearing, Needle	34	102112X	Shaft, Reduction (2nd)
5	1370H	Washer, Thrust 5/8 x 1.10 x 1/32	35	102101X	Screw, Whiz, Lock 5/16-18 x 3-1/2
6	137335	Pinion, Input	36	154355	Sprocket Assembly w/Bearing (Includes Key Nos. 37 and 38)
7	145101	Shaft, Input	37	4422J	Bearing, Needle
8	4895H	Bearing, Needle	38	154356	Sprocket, Tine
9	154467	Washer, Seal	39	105345X	Gear, Cluster, Red 1st & 2nd
10	7392M	Ball, Steel	40	105346X	Gear, Reverse
11	100371K	Spring, Shift, Fork	41	8358J	Shaft, Reduction (1st)
12	106160X	O-Ring	42	4220R	Washer, Thrust
13	142145	Arm, Shift	43	106146X	Spacer 1.01 x 1.75 x 0.760
14	8353J	Fork, Shift	44	155236	Seal Asm Oil
15	12000039	Ring, Klip	48	170338	Gearcase, R.H. w/Bearing (Includes Key No. 8)
16	154466	Shaft, Shift	49	132688	Shaft, Tine
18	4358J	Washer	50	106147X	Chain, Roller #50-50 Pitch
19	12000040	Ring, Klip	51	17720408	Screw 1/4-20 x 1/2
20	102114X	Gear, Assembly, Reverse Idler (Includes Key Nos. 21 and 22)	52	STD541031	* Nut, Hex 5/16-18
21	102115X	Gear, Reverse Idler	53	165140	Kit, Bearing
22	6803J	Bearing, Needle	54	17720412	Screw 1/4-20 x 3/4
23	102111X	Shaft, Reverse Idler	--	6066J	Grease, Plastilube #1
24	STD551143	* Washer, Lock 7/16	60	6855M	Fitting Grease
25	STD541143	* Nut, Hex 7/16-20			
27	143009	Bearing, Shaft, Ground Drive L.H.			
28	106390X	Spacer 0.765 x 1.125 x 1.23			
29	102134X	Chain #35-50 Pitch			
30	150737	Ground Shaft Assembly			

* STANDARD HARDWARE - - PURCHASE LOCALLY

NOTE: All component dimensions given in U.S. inches.
1 inch = 25.4 mm

REPAIR PARTS

TILLER - - MODEL NUMBER 917.293110

TINE SHIELD

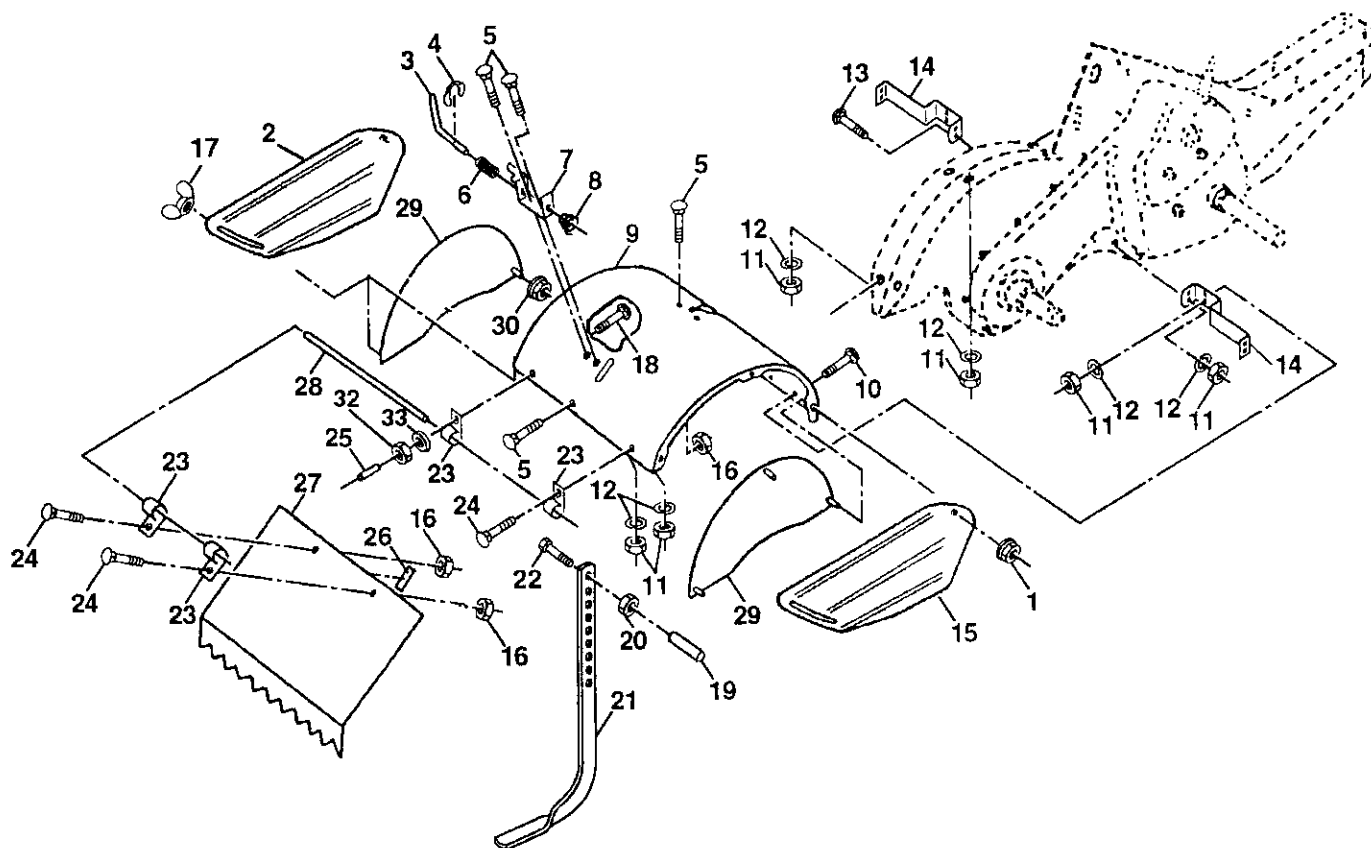

KEY NO.	PART NO.	DESCRIPTION
1	73900500	Nut, Lock Hex Flange 5/16-18
2	161415X558	Shield, Side, Outer L. H.
3	8393J	Pin, Stake, Depth
4	12000036	Ring, Klip
5	STD533107	* Bolt, Carriage 5/16-18 x 3/4 Gr 5
6	8394J	Spring
7	8392J	Bracket, Latch
8	109230X	Spring, Depth Stake
9	124289X558	Shield, Tine
10	STD533110	* Bolt, Carriage 5/16-18 x 1 Gr. 5
11	STD541031	* Washer, Lock 5/16
12	STD551131	* Nut, Hex 5/16-18
13	STD533112	Bolt, Carriage 5/16-18 x 1-1/4
14	124311X	Bracket, Shield Tine
15	161414X558	Shield, Side, Outer R.H.
16	73900400	* Nut, Hex Flange 1/4-20 x 1/2
17	162175	Nut, Wing Forged 5/16-18
18	STD532512	* Bolt, Carriage 1/4-20 x 1-1/4 Gr. 5

KEY NO.	PART NO.	DESCRIPTION
19	102701X	Grip
20	STD541037	* Nut, Hex 3/8-16
21	102156X	Stake, Depth
22	74930632	Bolt, Hex 3/8-16 x 2
23	4440J	Hinge
24	STD532505	* Bolt, Carriage 1/4-20 x 1/2
25	6712J	Cap, Vinyl
26	109227X	Pad, Idler
27	102695X558	Shield, Leveling
28	120588X	Pin, Hinge
29	124309X558	Shield, Side
30	73970500	Locknut, Hex, Flange

* STANDARD HARDWARE - - PURCHASE LOCALLY

NOTE: All component dimensions given in U.S. inches.
1 inch = 25.4 mm

REPAIR PARTS

TILLER - - MODEL NUMBER 917.293110

TINE ASSEMBLY

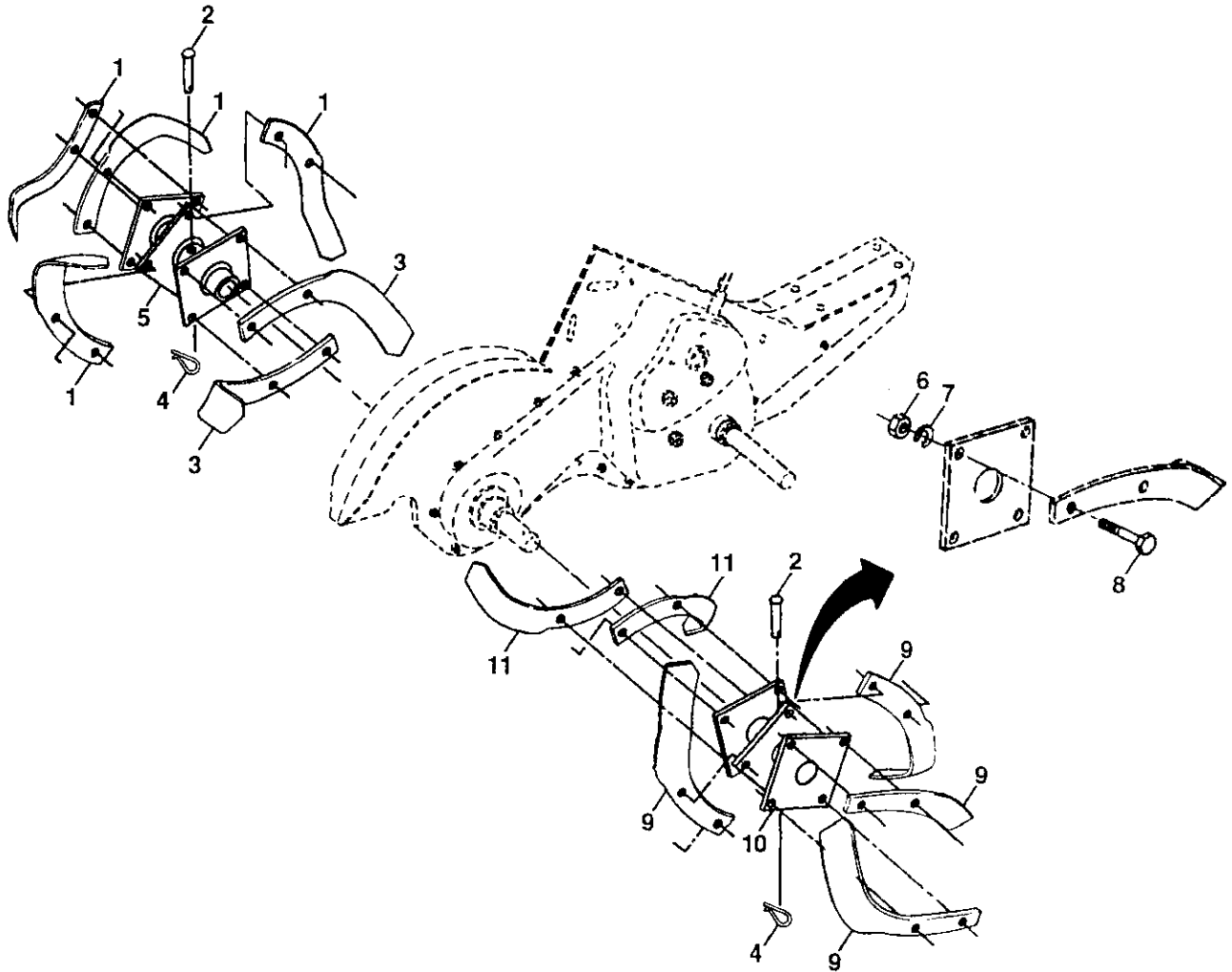

KEY NO.	PART NO.	DESCRIPTION
1	4459J	Tine, Outer, L.H.
2	132673	Pin, Shear
3	6554J	Tine, Inner, L.H.
4	3146R	Retainer, Spring
5	132727	Assembly, Hub and Plate, L.H.
6	73610600	Nut, Hex 3/8-24
7	STD551137	*Washer, Lock 3/8
8	74610616	Bolt, Hex 3/8-24 x 1

KEY NO.	PART NO.	DESCRIPTION
9	4460J	Tine, Outer, R.H.
10	132728	Assembly, Hub and Plate, R.H.
11	6555J	Tine, Inner, R.H.

*STANDARD HARDWARE--PURCHASE LOCALLY

NOTE: All component dimensions given in U.S. inches.
1 inch = 25.4 mm

REPAIR PARTS

TILLER - - MODEL NUMBER 917.293110

DECALS

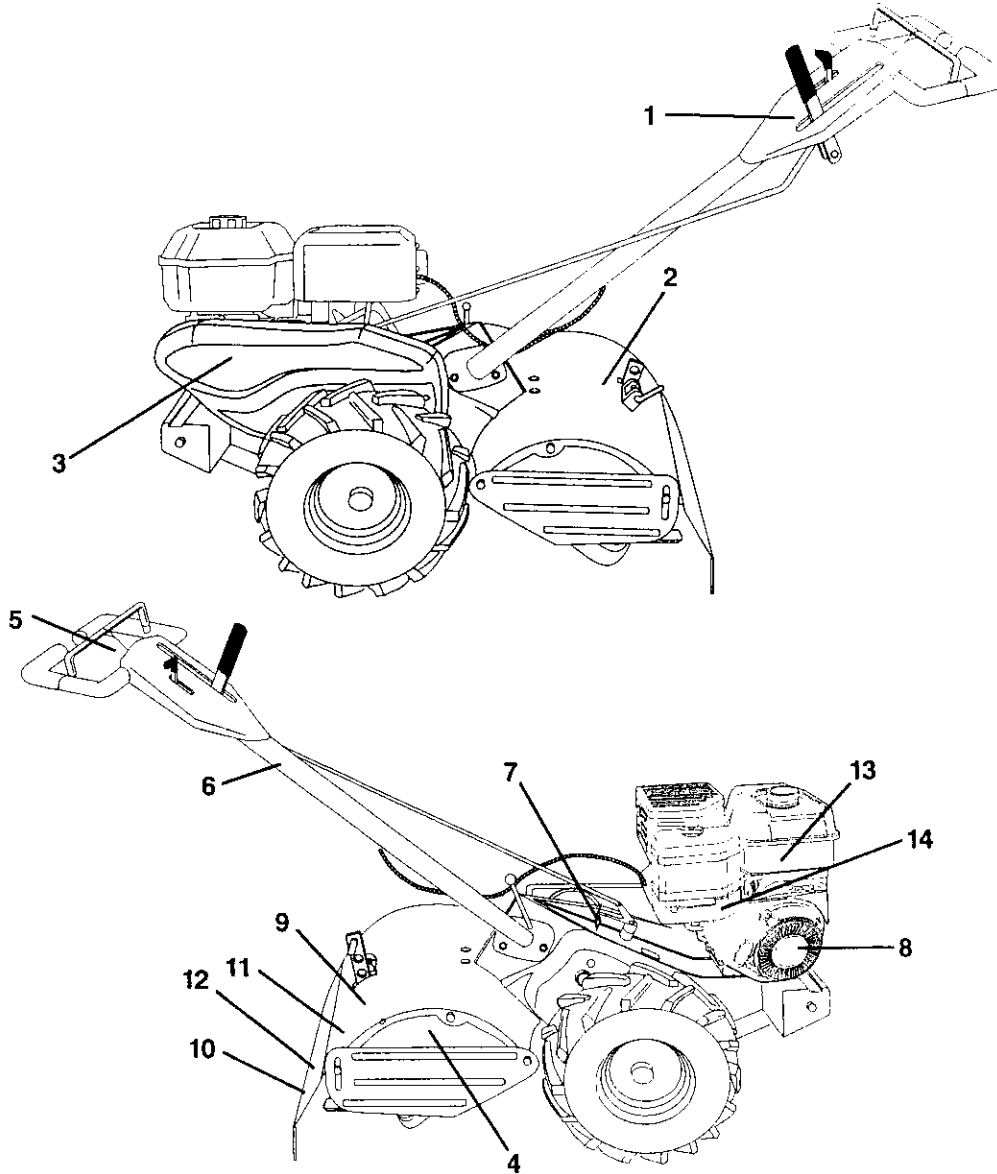

KEY NO.	PART NO.	DESCRIPTION
1	169277	Decal, Logo, Control Panel
2	166133	Decal, Logo, Tine Shield
3	166134	Decal, Logo, Belt Guard
4	157984	Decal, Description
5	137282	Decal, Caution, Drive Control
6	159877	Decal, Hand Placement
7	102180X	Decal, Shift Indicator
8	171078	Decal, Rewind
9	168260	Decal, Depth Stake
10	156129	Decal, Warning Rotating Tines
11	166138	Decal, Engine
12	145437	Decal, Europe Stand CE
13	167156	Decal, Intek
14	171076	Decal, Engine
--	172182	Manual, Operator's (Euro)
--	172183	Manual, Operator's (Scand)
--	172184	Manual, Repair Parts

REPAIR PARTS

TILLER - - MODEL NUMBER 917.293110

ENGINE, BRIGGS & STRATTON -- MODEL NUMBER 110402, TYPE NO. 0180-E1

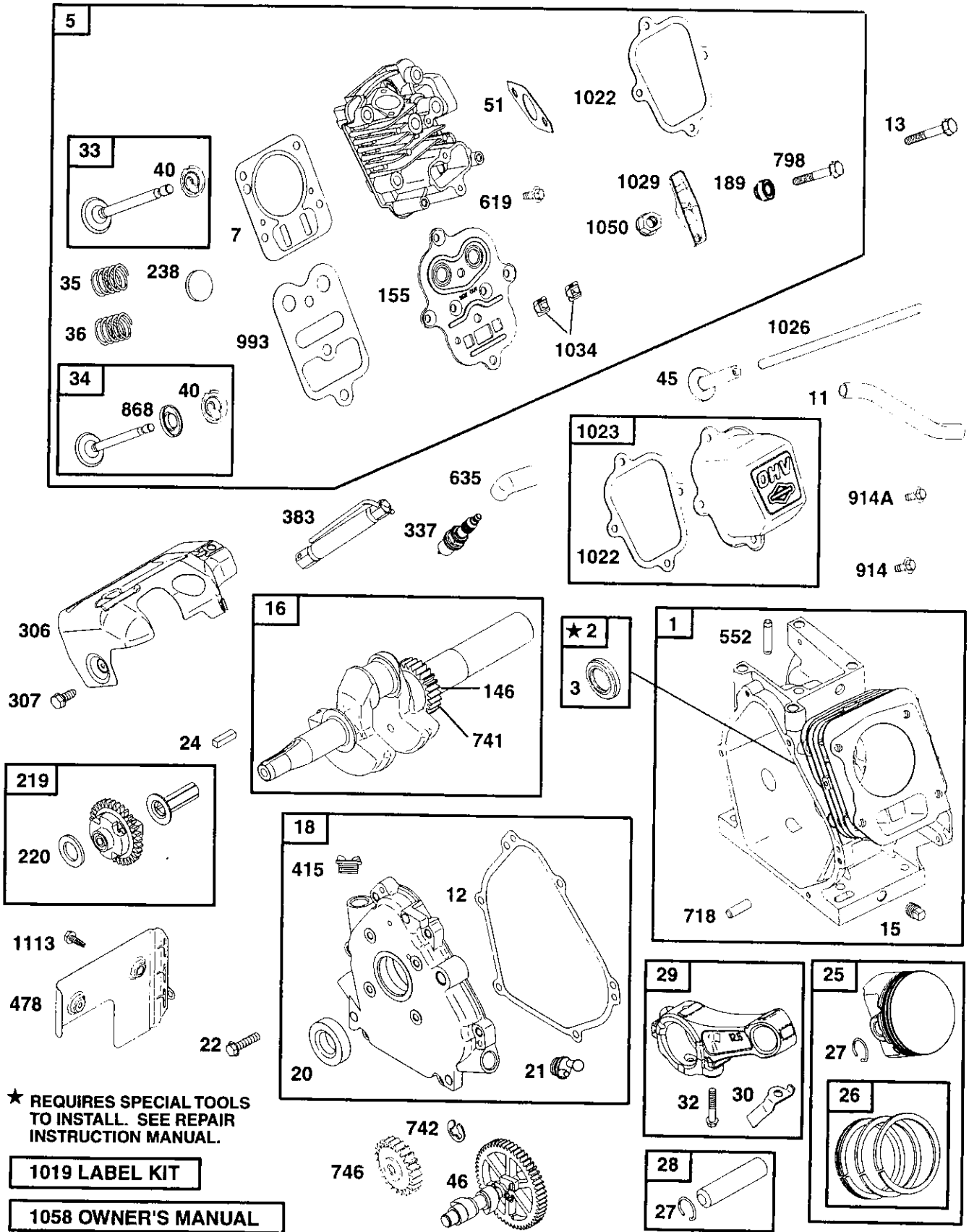

★ REQUIRES SPECIAL TOOLS TO INSTALL. SEE REPAIR INSTRUCTION MANUAL.

1019 LABEL KIT

1058 OWNER'S MANUAL

REPAIR PARTS

TILLER - - MODEL NUMBER 917.293110

ENGINE, BRIGGS & STRATTON -- MODEL NUMBER 110402, TYPE NO. 0180-E1

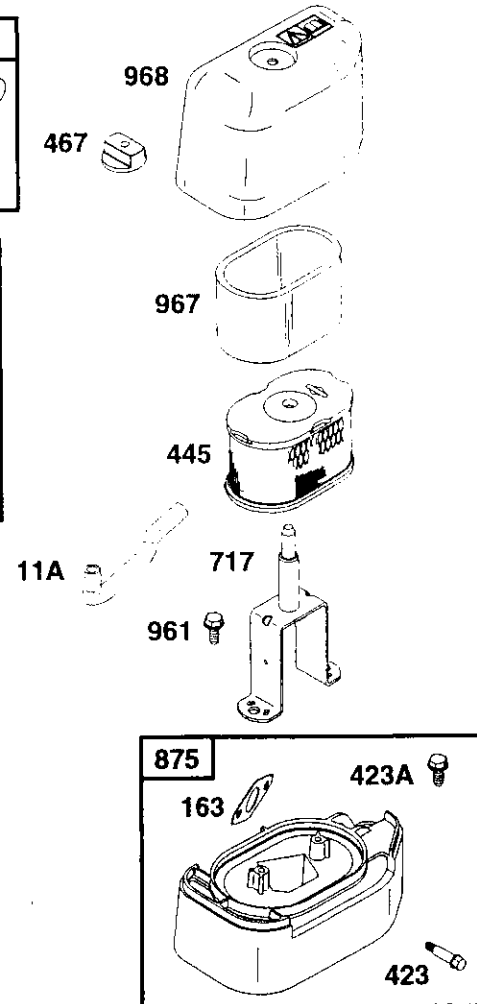
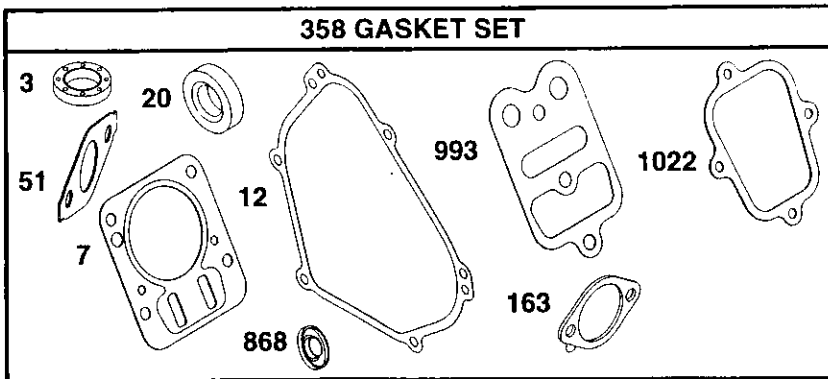
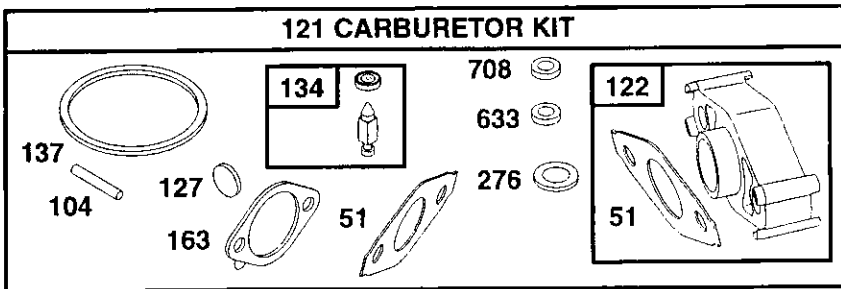
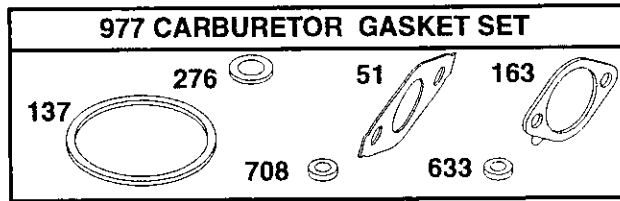
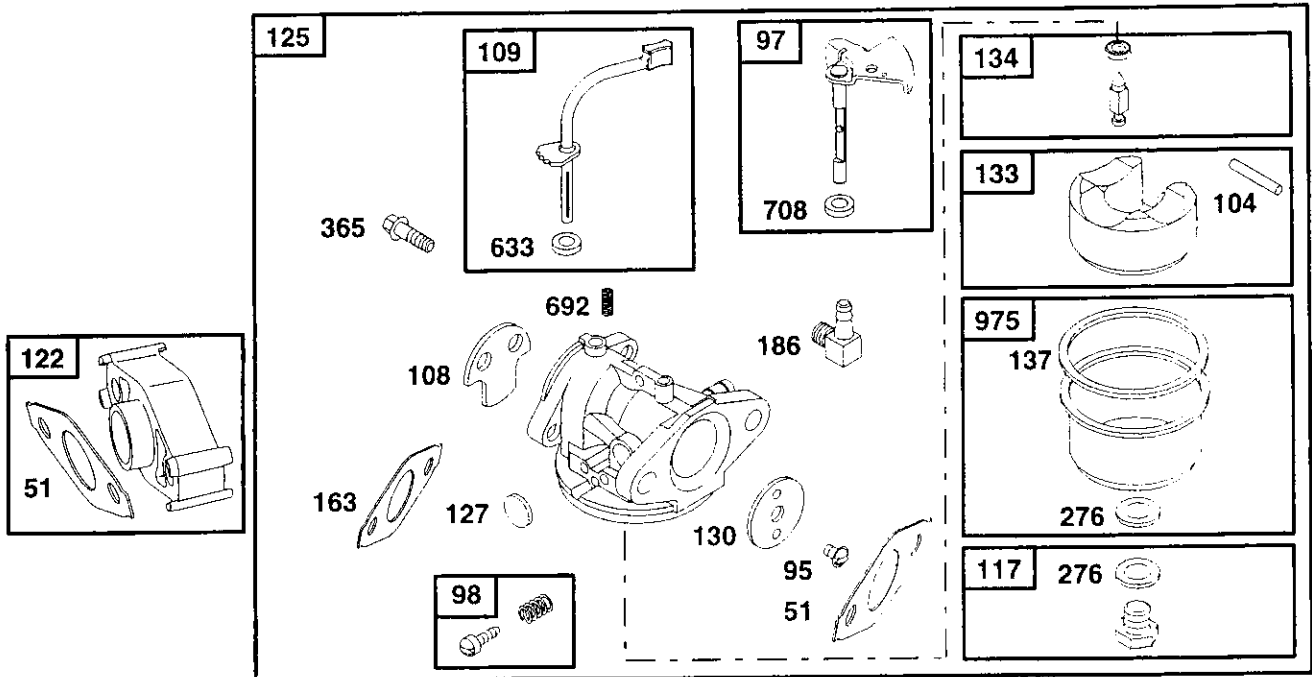

REPAIR PARTS

TILLER - - MODEL NUMBER 917.293110

ENGINE, BRIGGS & STRATTON -- MODEL NUMBER 110402, TYPE NO. 0180-E1

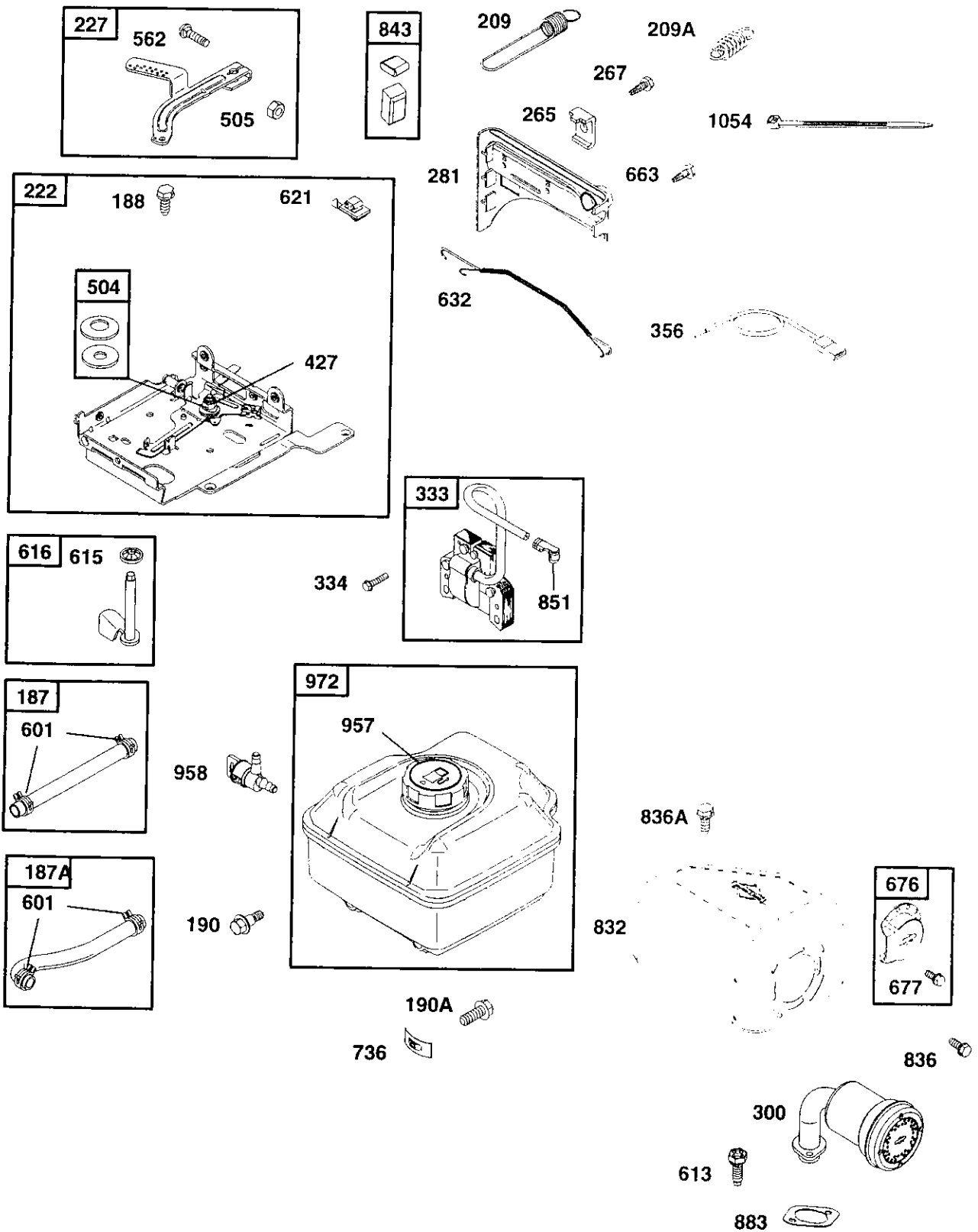

REPAIR PARTS

TILLER - - MODEL NUMBER 917.293110

ENGINE, BRIGGS & STRATTON -- MODEL NUMBER 110402, TYPE NO. 0180-E1

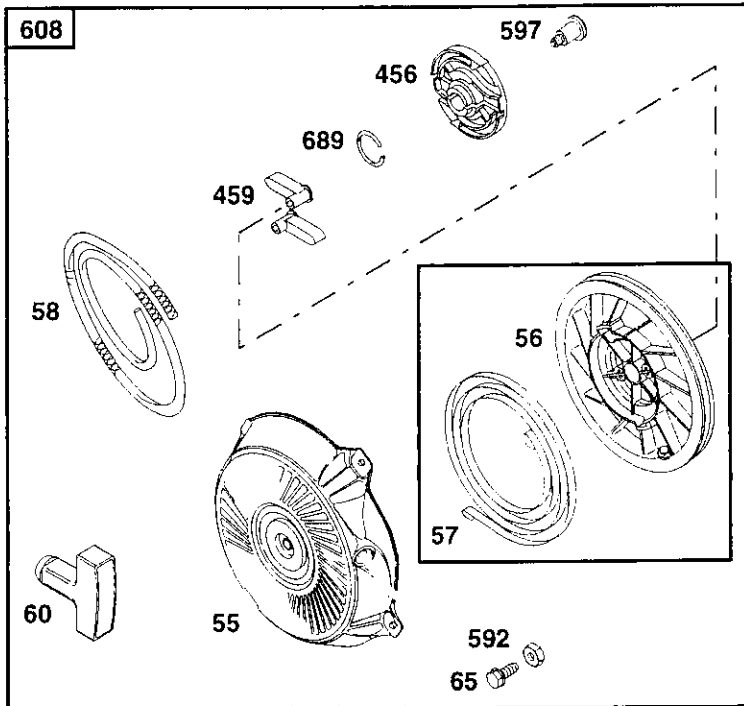

1036 EMISSIONS LABEL

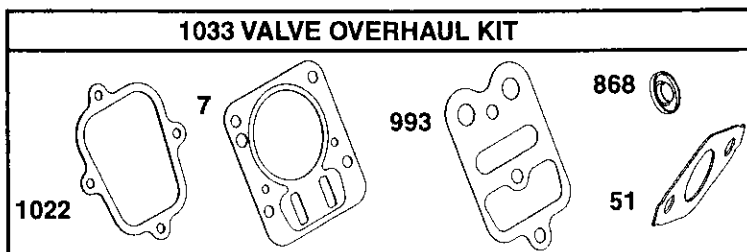
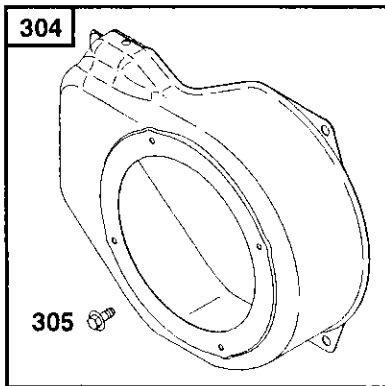
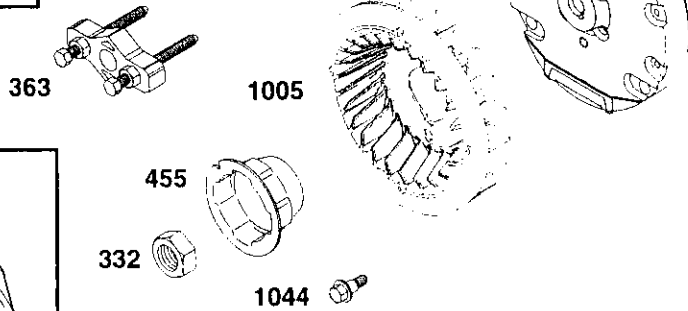

REPAIR PARTS

TILLER - - MODEL NUMBER 917.293110

ENGINE, BRIGGS & STRATTON -- MODEL NUMBER 110402, TYPE NO. 0180-E1

KEY PART NO. NO.	DESCRIPTION	KEY PART NO. NO.	DESCRIPTION		
1	693811	Cylinder Assembly	125	694112	Carburetor
2	399269	Bushing/Seal Kit	127	223472	● Welch Plug
3	299819	☆ Oil Seal	130	691181	Throttle Valve
5	693643	Cylinder Head	133	398187	Carburetor Float
7	273489	☆+ Cylinder Head Gasket	134	398188	● Needle Valve
11	692600	Breather Tube	137	693981	● ◆ Float Bowl Gasket
11A	693647	Breather Tube	146	94388	Timing Key
12	692549	☆ Crankcase Gasket	155	692556	Cylinder Head Plate
13	691137	Screw (Cylinder Head)	163	693458 ☆+ ● ◆	Air Cleaner Gasket
15	94916	Oil Drain Plug	186	493496	Hose Connector
16	693797	Crankshaft	187	492790	Fuel Line (Cut to Required Length)
18	694466	Crankcase Cover	187A	692601	Fuel Line (Molded)
20	692550	☆ Oil Seal	188	94644	Screw (Control Bracket)
21	281658	Oil Fill Cap	189	691295	Rocker Arm Ball
22	692551	Screw (Crankcase Cover)	190	692127	Screw (Fuel Tank)
23	692987	Flywheel	190A	94644	Screw (Fuel Tank)
24	222698	Flywheel Key	209	693710	Governor Spring
25	690021	Piston Assembly (Standard)	209A	261306	Governor Spring
	694167	Piston Assembly (.010" O/S)	219	693578	Governor Gear
	694168	Piston Assembly (.020" O/S)	220	221551	Washer (Governor Gear)
	694169	Piston Assembly (.030" O/S)	222	694253	Control Bracket
26	499631	Ring Set (Standard)	227	692573	Governor Lever
	692785	Ring Set (.010" O/S)	238	691300	Valve Cap
	692786	Ring Set (.020" O/S)	265	221535	Casing Clamp
	692787	Ring Set (.030" O/S)	267	692577	Screw (Casing Clamp)
27	263190	Piston Pin Lock	276	271716	● ◆ Sealing Washer
28	499423	Piston Pin	281	694252	Control Panel
29	499424	Connecting Rod	300	693593	Exhaust Muffler
30	692562	Connecting Rod Dipper	304	693621	Housing-Blower
32	94699	Screw (Connecting Rod)	305	692608	Screw (Blower Housing)
33	499642	Exhaust Valve	306	693610	Cylinder Shield
34	499641	Intake Valve	307	690345	Screw (Cylinder Shield)
35	691304	Valve Spring (Intake)	332	94877	Nut (Flywheel)
36	691304	Valve Spring (Exhaust)	333	692605	Armature-Magneto
40	93312	Valve Retainer	334	94731	Screw (Magneto Armature)
45	262679	Valve Tappet	337	491055	Sparkplug
46	693404	Camshaft	356	398808	Stop Wire
51	692555 ☆+ ● ◆	Intake Gasket (2 Required)	358	690031	Gasket Set
55	691422	Rewind Starter Housing	363	19069	Flywheel Puller
56	498144	Pulley/Spring Assembly	365	692568	Screw (Carburetor)
57	498144	Pulley/Spring Assembly			
58	693449	Starter Rope			
60	391101	Starter Rope Grip			
65	94904	Screw (Rewind Starter)			
95	94098	Screw (Throttle Valve)			
97	690024	Throttle Shaft			
98	398185	Idle Speed Kit			
104	691242	● Float Hinge Pin			
108	692567	Choke Valve			
109	693628	Choke Shaft			
117	493763	Main Jet			
121	690032	Carburetor Kit			
122	693749	● Carburetor Spacer			

RPM Settings: Low Speed: 1900-2100
High Speed: 3000-3200

☆ Included in Gasket Set, Ref Number 358.
● Included in Carburetor Kit, Ref Number 121.
◆ Included in Carburetor Gasket Set, Ref Number 977.
+ Included in Value Overhaul Kit, Ref Number 1033.

NOTE: All component dimensions given in U.S. inches
1 inch = 25.4 mm

REPAIR PARTS

TILLER - - MODEL NUMBER 917.293110

ENGINE, BRIGGS & STRATTON -- MODEL NUMBER 110402, TYPE NO. 0180-E1

KEY PART NO.	NO.	DESCRIPTION	KEY PART NO.	NO.	DESCRIPTION
383	19374	Spark Plug Wrench	832	693583	Muffler Guard
415	693463	Oil Fill Plug	836	94896	Screw (Muffler Guard)
423	690349	Screw (Air Cleaner Base)	836A	693624	Screw (Mounting)
423A	94929	Screw (Air Cleaner Base)	843	694061	Lever Sleeve
427	692575	Nut (Control Bracket)	851	493880	Sparkplug Terminal
445	690610	A/C Cartridge Filter	868	498592	★+ Valve Seal
455	692591	Flywheel Cup	875	693459	Air Cleaner Base
456	281503	Pawl Friction Plate	883	272309	Exhaust Gasket
459	281505	Ratchet Pawl	914	94786	Screw (Rocker Cover 7/16" Long)
467	493903	Air Cleaner Knob	914A	692557	Screw (Rocker Cover 3/8" Long)
478	693709	Panel	957	493988	Fuel Tank Cap
504	495659	Washer Set	958	692586	Shutoff Valve
505	231082	Nut (Governor Control Lever)	961	693598	Screw (Air Cleaner Bracket)
552	692346	Governor Crank Bushing	967	273356	Pre-Cleaner Filter
562	94852	Bolt (Governor Control Lever)	968	693460	Air Cleaner Cover
592	94908	Nut (Rewind Starter)	972	692587	Fuel Tank
597	94943	Screw (Pawl Friction Plate)	975	493640	Float Bowl
601	95162	Hose Clamp	977	690033	Carburetor Gasket Set
608	497830	Rewind Starter	993	691892	★+ Cylinder Head Plate Gasket
613	94706	Screw (Muffler)	1005	692592	Fan-Flywheel
615	692576	Governor Shaft Retainer	1019	690035	Label Kit
616	692547	Governor Crank	1022	693790	★+ Rocker Cover Gasket
619	691108	Screw (Cylinder Head Plate)	1023	499924	Rocker Cover
621	396847	Stop Switch	1026	693517	Push Rod
632	693408	Spring/Link (Mechanical Governor)	1029	691230	Rocker Arm
633	693867	● ◆ Washer (Choke Shaft)	1033	690034	Valve Overhaul Kit
635	805529	Spark Plug Boot	1034	691343	Push Rod Guide
663	694593	Screw (Control Panel)	1036	695041	Emissions Label
676	393757	Muffler Deflector	1044	692590	Screw (Flywheel)
677	94896	Screw (Muffler Deflector)	1050	692558	Nut (Rocker Arm)
689	263073	Friction Spring	1054	280275	Cable Tie
692	690572	Detent Spring (Choke)	1058	273700	Owner's Manual
708	691321	Washer (Throttle Shaft)	1113	692577	Screw (Panel)
717	693462	Air Cleaner Bracket	— —	121432-0036-E2	Replacement Engine
718	230192	Locating Pin			
736	693560	Nut Clip			
741	263157	Timing Gear			
742	692564	Ring-Retaining			
746	692566	Gear-Idler			
798	692559	Screw (Rocker Arm)			

RPM Settings: Low Speed: 1900-2100
High Speed: 3000-3200

- ★ Included in Gasket Set, Ref Number 358.
- Included in Carburetor Kit, Ref Number 121.
- ◆ Included in Carburetor Gasket Set, Ref Number 977.
- + Included in Valve Overhaul Kit, Ref Number 1033.

NOTE: All component dimensions given in U.S. inches
1 inch = 25.4 mm