

**REPAIR PARTS MANUAL**  
**MODEL NO. 293583**  
**6.5 HP 17 Inch**  
**Tiller**



# REPAIR PARTS

## TILLER - - MODEL NUMBER 917.293583

### HANDLES

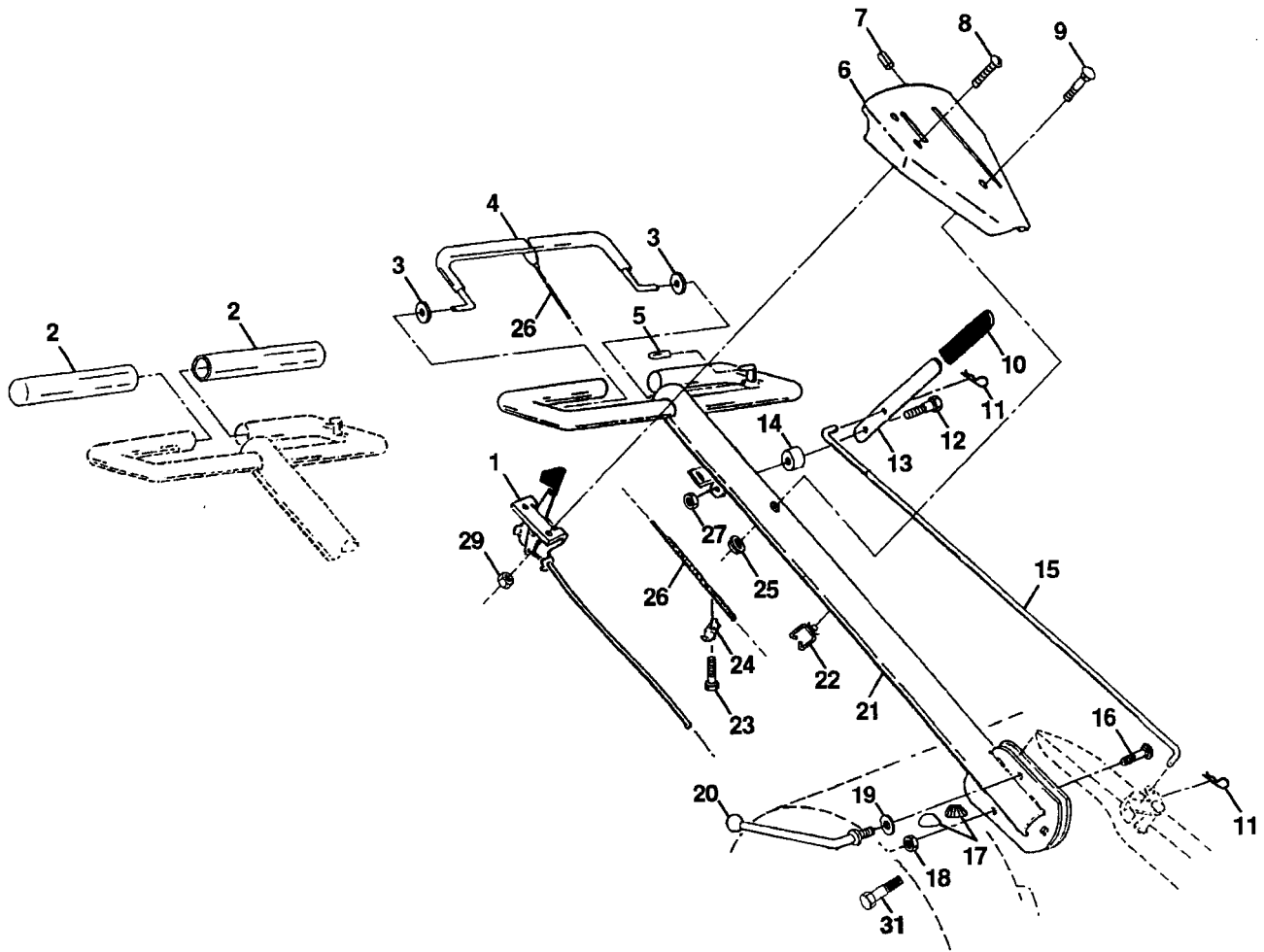

KEY NO.	PART NO.	DESCRIPTION
1	180634	Throttle, Control
2	141406	Grip, Handle
3	110673X	Grommet, Handle
4	127254X	Bar, Assembly Control
5	6712J	Cap, Vinyl
6	180500	Panel, Control
7	110641X	Bushing, Split
8	71191008	Screw 10-24
9	72010520	Bolt, 5/16-18 x 2.50
10	110646X	Handle, Grip
11	STD624003	Clip, Hairpin
12	81328	Bolt, Shoulder
13	110741X	Handle, Shift
14	109313X	Grommet, Rubber
15	110702X	Rod, Shift
16	STD533710	Bolt, Carriage 3/8-16 x 1 Gr. 5

KEY NO.	PART NO.	DESCRIPTION
17	109229X	Lock, Handle
18	STD541437	Nut, Centerlock 3/8-16
19	19131611	Washer 13/32 x 1 x 11 Ga.
20	109228X	Lever, Lock, Handle
21	150258	Column, Handle, Asm.
22	165197	Clip, Nyl Blk, Cable
23	86777	Screw, Hex, Washer #10-24 x 1/2
24	9484R	Clip
25	73970500	Locknut, Hex, Flange
26	110675X	Clutch, Cable
27	73900400	Nut, Lock 1/4-20
29	STD541462	Nut, Keps #10-24
31	150696	Bolt, Pivot

**NOTE:** All component dimensions given in U.S. inches.  
1 inch = 25.4 mm

# REPAIR PARTS

## TILLER - - MODEL NUMBER 917.293583

### MAINFRAME, LEFT SIDE

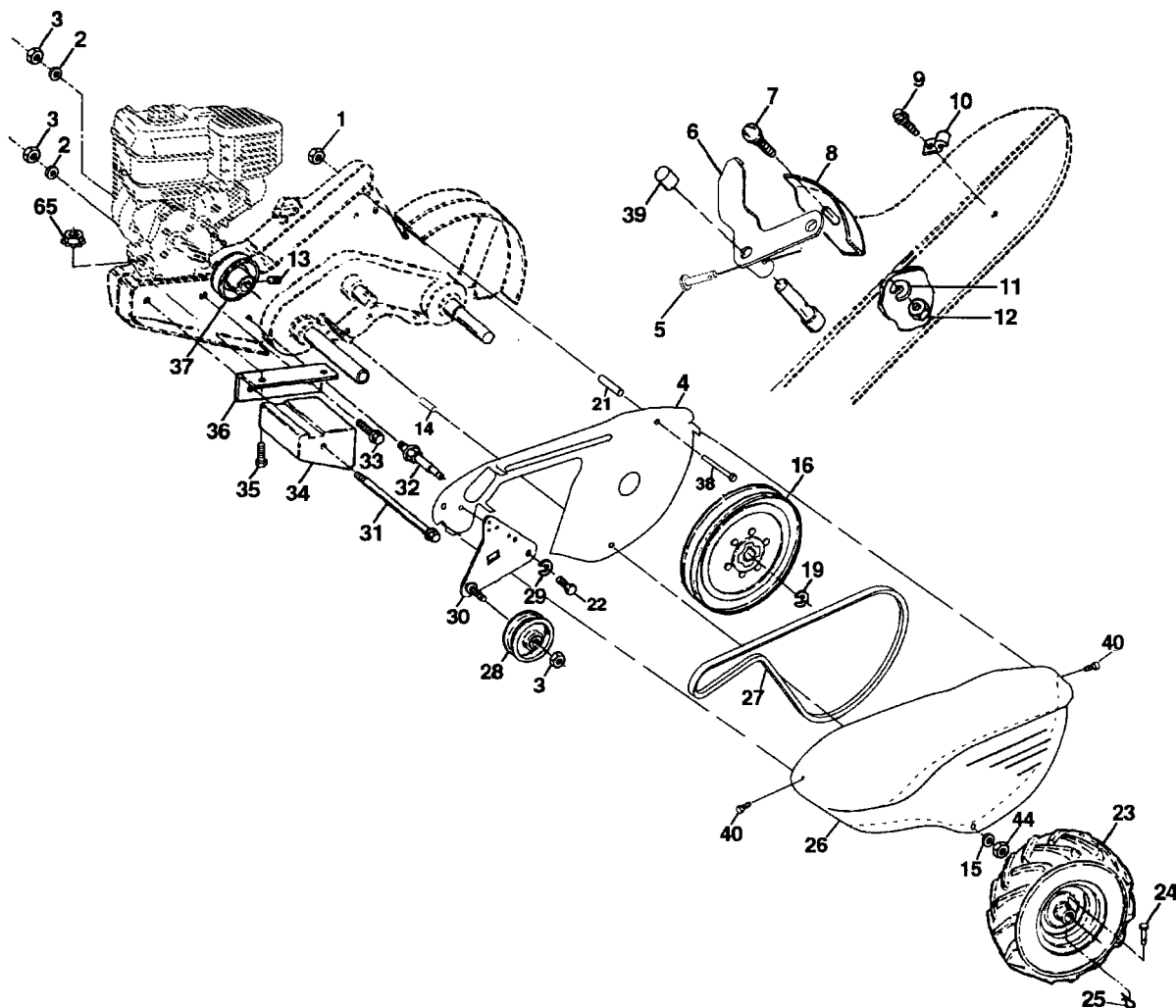

KEY NO.	PART NO.	DESCRIPTION
1	73970500	Nut, Keps 5/16-18
2	STD551137	Washer, Lock 3/8
3	STD541037	Nut, Hex 3/8-16
4	170127	Shield Inner Belt Guard
5	164329	Pin Spirol Flared
6	110111X	Lever, Shift
7	STD532505	Bolt, Carriage 1/4-20 x 1/2 Gr. 5
8	8700J	Plate, Shift Indicator
9	86777	Screw, Hex, Washer Head, Slotted #10-24 x 1/2
10	9484R	Clip
11	STD551125	Washer, Lock 1/4
12	STD541025	Nut, Hex 1/4-20
13	23230506	Screw, Set, Hex 5/16-18 x 3/8
14	156117	Spacer, Split .327 x .42 x 1.220
15	STD551031	Washer 11/32 x 11/16 x 16 Ga.
16	145102	Sheave, Transmission
19	12000028	Ring, Retainer
21	110652X	Spacer, Split .327 x .42 x 2.09
22	74770508	Bolt Fin Hex 5/16-24 UNF x 1/2
23	102190X	Tire
	150750	Rim
	795R	Tire Valve

KEY NO.	PART NO.	DESCRIPTION
24	126875X	Rivet, Drilled
25	STD624003	Retainer Spring
26	165501X558	Guard, Belt
27	132801	Belt, V
28	104679X	Pulley, Idler
29	12000032	Ring, Klip
30	159229	Bracket, Idler
31	102384X	Bolt, Hex 5/16-16 x 12
32	102141X	Shaft, Idler Arm
33	STD523710	Bolt, Hex 3/8-16 x 1
34	102383X	Counterweight, L. H.
35	74760524	Bolt, Hex 5/16-18 x 1-1/2
36	102331X	Bracket, Reinforcement, L. H.
37	130812	Sheave, Engine
38	74760544	Bolt Fin Hex 5/16-18 Unc x 2-3/4
39	140062	Cap, Plunger
40	170488	Screw Hex Wsh Slit #10-24 x 50
43	69180	Nut Lock #10-24
44	STD541431	Nut Lock Hx W/Ins 5/16-18 Unc
65	73510500	Nut, Keps 5/16-18

**NOTE:** All component dimensions given in U.S. inches.  
1 inch = 25.4 mm

# REPAIR PARTS

## TILLER - - MODEL NUMBER 917.293583

### MAINFRAME, RIGHT SIDE

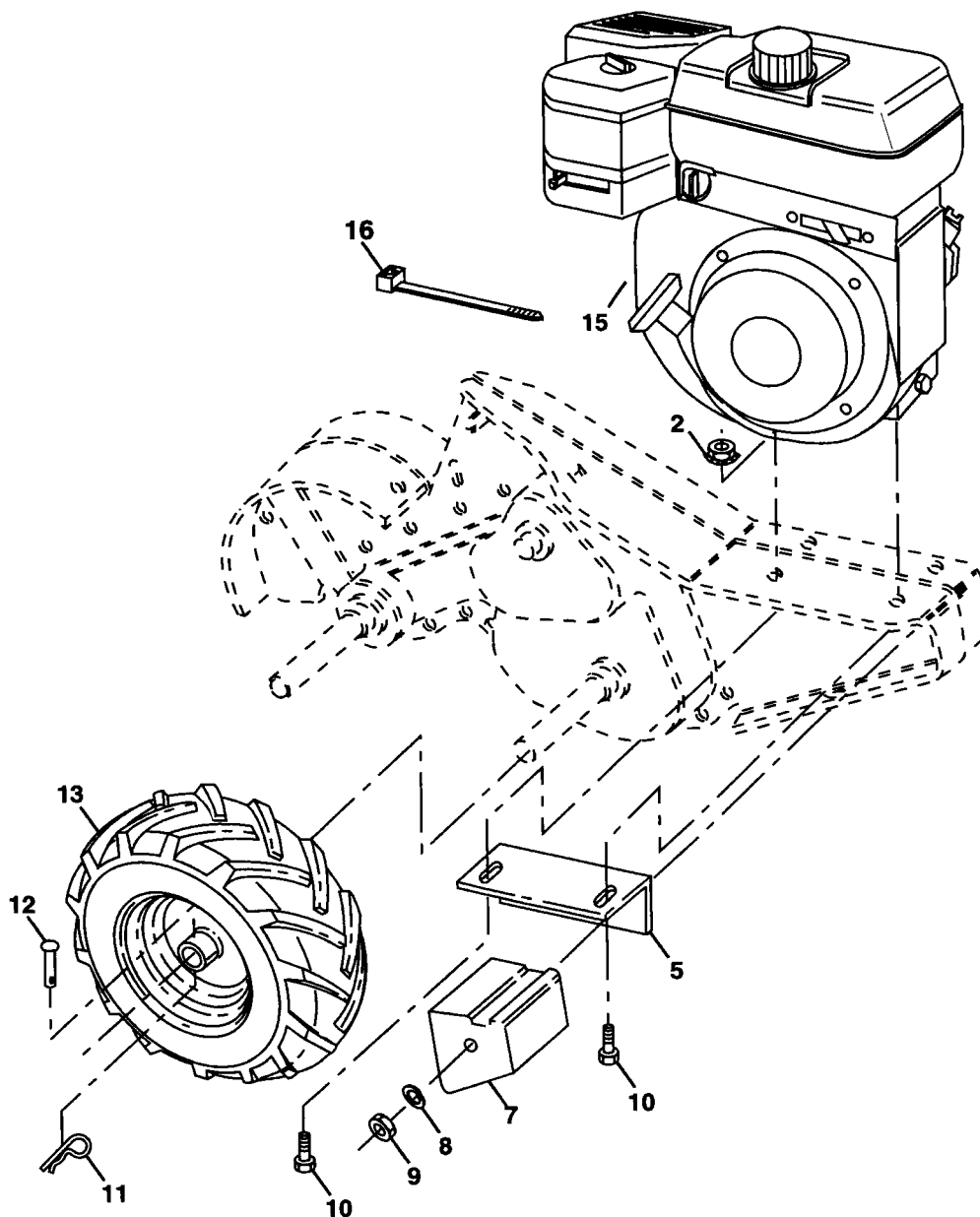

KEY NO.	PART NO.	DESCRIPTION
2	73970500	Locknut, Hex, Flange 5/16-18
5	102332X	Bracket, Reinforcement
7	102173X	Counter Weight, R.H.
8	STD551137	Washer, Lock 3/8
9	STD541037	Nut, Hex 3/8-16
10	74760524	Bolt, Hex 5/16-18 x 1-1/2
11	STD624003	Retainer Spring
12	126875X	Rivet, Drilled

KEY NO.	PART NO.	DESCRIPTION
13	102190X	Tire
	183122X624	Rim
	795R	Tire Valve
15	-----	Engine(See breakdown) Briggs Model 120402-0213-E1
16	7192J	Tie Cable

**NOTE:** All component dimensions given in U.S.inches.  
1 inch = 25.4 mm

# REPAIR PARTS

## TILLER - - MODEL NUMBER 917.293583

### TRANSMISSION

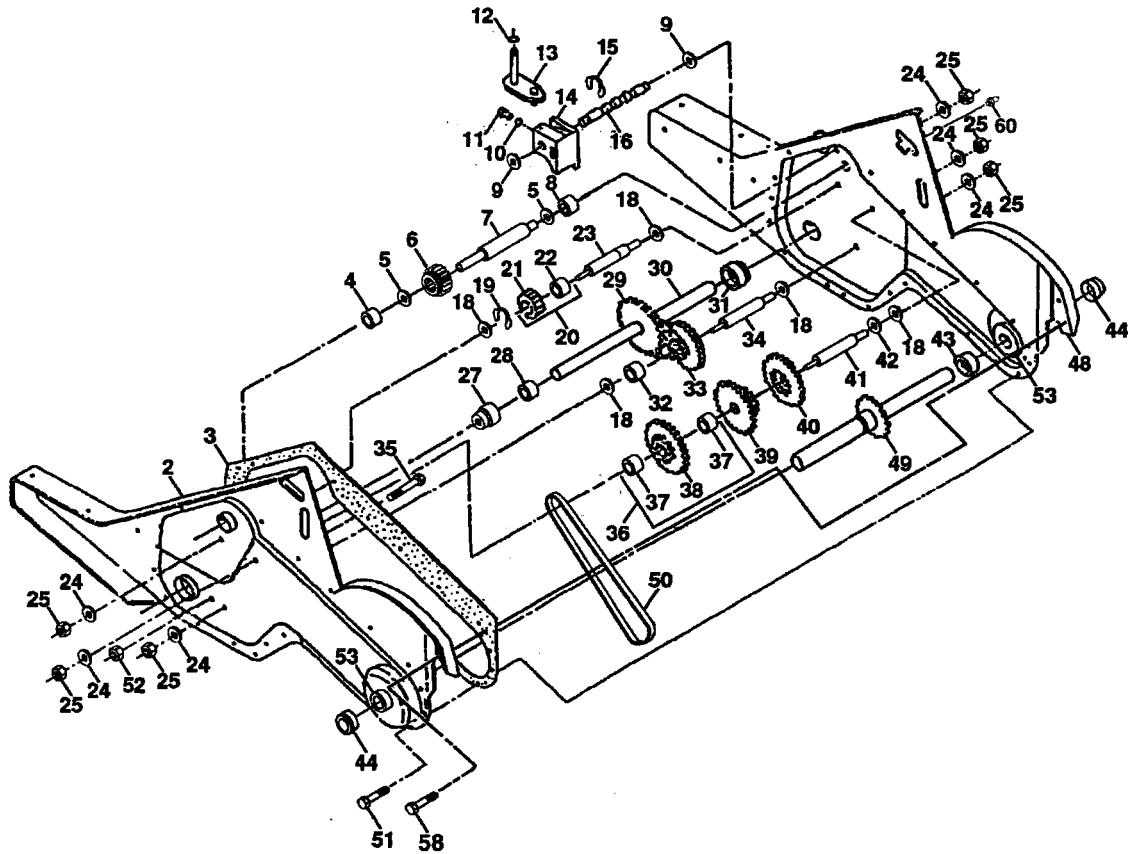

KEY NO.	PART NO.	DESCRIPTION	KEY NO.	PART NO.	DESCRIPTION
1	180677	Transmission Assembly (Includes Key Nos. 2-52)	29	102134X	Chain #35-50 Pitch
2	180627	Gearcase, L.H. w/Bearing (Includes Key No. 4)	30	150737	Ground Shaft Assembly
3	161963	Gasket, Gearcase	31	143008	Bearing, Shaft, Ground Drive R.H.
4	5020J	Bearing, Needle	32	106388X	Spacer 0.70 x 1.00 x 1.150
5	1370H	Washer, Thrust 5/8 x 1.10 x 1/32	33	102121X	Sprocket and Gear Assembly
6	137335	Pinion, Input	34	102112X	Shaft, Reduction (2nd)
7	145101	Shaft, Input	35	102101X	Screw, Whiz, Lock 5/16-18 x 3-1/2
8	4895H	Bearing, Needle	36	154355	Sprocket Assembly w/Bearing (Includes Key Nos. 37 and 38)
9	154467	Washer, Seal	37	4422J	Bearing, Needle
10	7392M	Ball, Steel	38	154356	Sprocket, Tine
11	100371K	Spring, Shift, Fork	39	105345X	Gear, Cluster, Red 1st & 2nd
12	106160X	O-Ring	40	105346X	Gear, Reverse
13	142145	Arm, Shift	41	8358J	Shaft, Reduction (1st)
14	8353J	Fork, Shift	42	4220R	Washer, Thrust
15	12000039	Ring, Klip	43	106146X	Spacer 1.01 x 1.75 x 0.760
16	154466	Shaft, Shift	44	155236	Seal Asm Oil
18	4358J	Washer	48	180631	Gearcase, R.H. w/Bearing (Includes Key No. 8)
19	12000040	Ring, Klip	49	132688	Shaft, Tine
20	102114X	Gear, Assembly, Reverse Idler (Includes Key Nos. 21 and 22)	50	106147X	Chain, Roller #50-50 Pitch
21	102115X	Gear, Reverse Idler	51	17720408	Screw 1/4-20 x 1/2
22	6803J	Bearing, Needle	52	STD541031	Nut, Hex 5/16-18
23	102111X	Shaft, Reverse Idler	53	165140	Kit, Bearing
24	STD551143	Washer, Lock 7/16	58	179520	Bolt Shoulder
25	STD541143	Nut, Hex 7/16-20	60	6855M	Fitting Grease
27	143009	Bearing, Shaft, Ground Drive L.H.	--	6066J	Grease, Plastilube #1
28	106390X	Spacer 0.765 x 1.125 x 1.23			

**NOTE:** All component dimensions given in U.S. inches.  
1 inch = 25.4 mm

# REPAIR PARTS

## TILLER - - MODEL NUMBER 917.293583

### TINE SHIELD

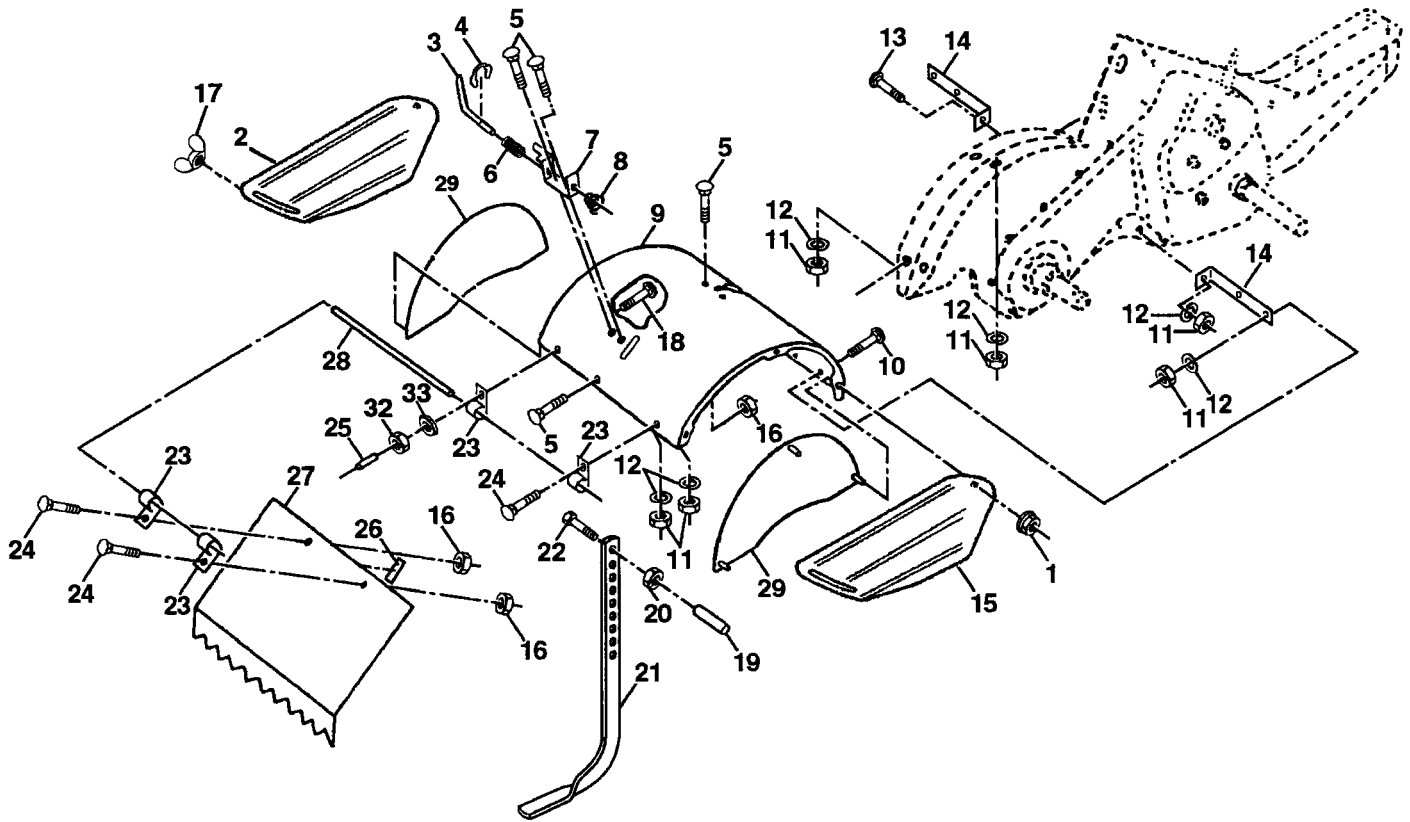

KEY NO.	PART NO.	DESCRIPTION
1	73900500	Nut, Lock Hex Flange 5/16-18
2	161415X558	Shield, Side, Outer L. H.
3	8393J	Pin, Stake, Depth
4	12000036	Ring, Klip
5	180847	Bolt, Carriage 5/16-18 x 3/4
6	8394J	Spring
7	8392J	Bracket, Latch
8	109230X	Spring, Depth Stake
9	102326X558	Shield, Tine
10	STD533110	Bolt, Carriage 5/16-18 x 1 Gr. 5
11	STD541031	Washer, Lock 5/16
12	STD551131	Nut, Hex 5/16-18
13	STD533112	Bolt, Carriage 5/16-18 x 1-1/4
14	124343X	Bracket, Shield Tine
15	161414X558	Shield, Side, Outer R.H.
16	73900400	Nut, Hex Flange 1/4-20 x 1/2
17	162175	Nut, Wing Forged 5/16-18

KEY NO.	PART NO.	DESCRIPTION
18	STD532512	Bolt, Carriage 1/4-20 x 1-1/4 Gr.
19	102701X	Grip
20	STD541037	Nut, Hex 3/8-16
21	102156X	Stake, Depth
22	74930632	Bolt, Hex 3/8-16 x 2
23	4440J	Hinge
24	STD532505	Bolt, Carriage 1/4-20 x 1/2
25	6712J	Cap, Vinyl
26	109227X	Pad, Idler
27	102695X558	Shield, Leveling
28	120588X	Pin, Hinge
29	104085X558	Shield, Side
32	73220400	Nut, Fin, Hex 1/4-20 UNC
33	STD551125	Washer Lock Hvy Helical 1/4

**NOTE:** All component dimensions given in U.S. inches.  
1 inch = 25.4 mm

# REPAIR PARTS

TILLER - - MODEL NUMBER 917.293583

## TINE ASSEMBLY

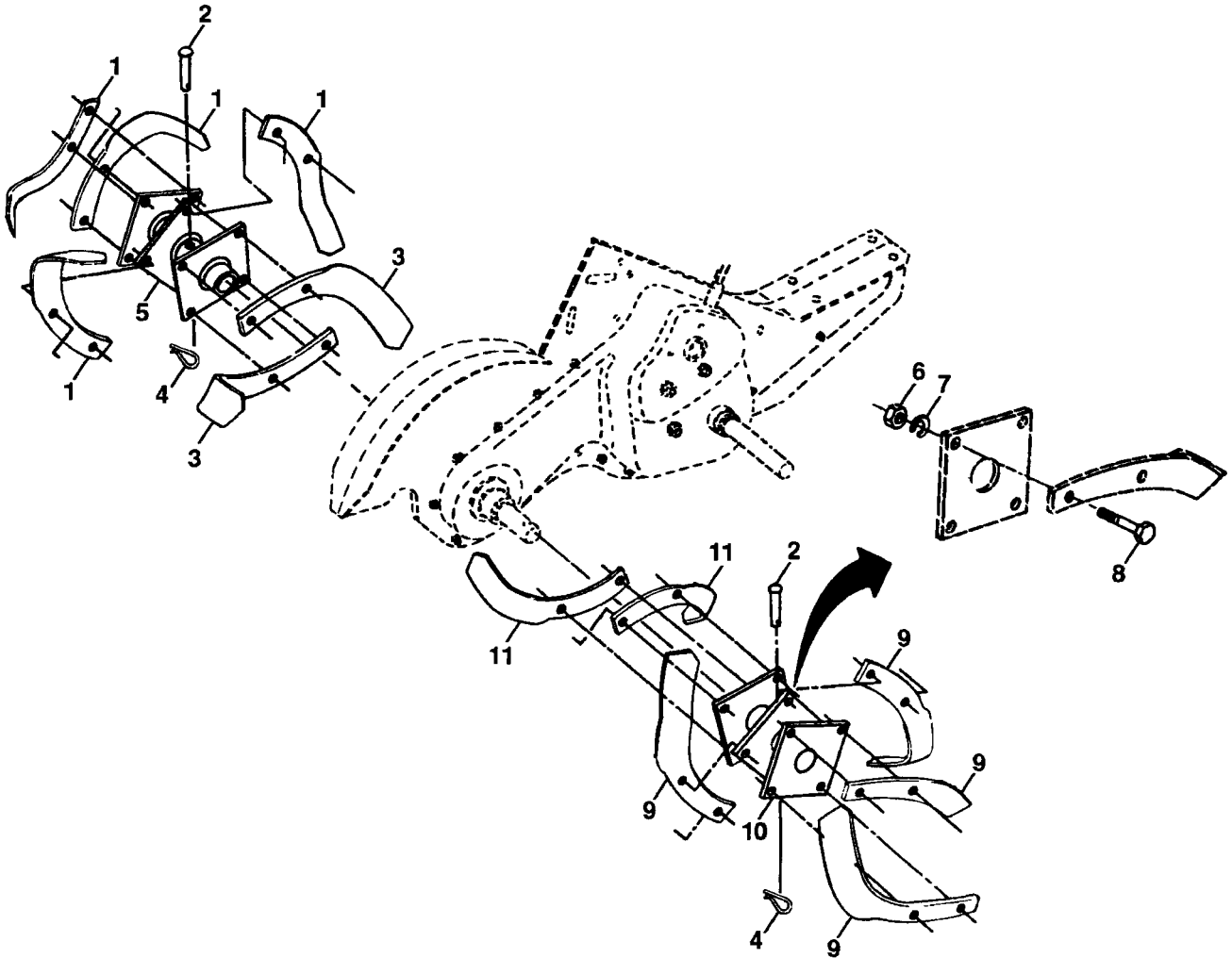

KEY NO.	PART NO.	DESCRIPTION
1	4459J	Tine, Outer, L.H.
2	132673	Pin, Shear
3	6554J	Tine, Inner, L.H.
4	3146R	Retainer, Spring
5	132727	Assembly, Hub and Plate, L.H.
6	73610600	Nut, Hex 3/8-24
7	STD551137	Washer, Lock 3/8

KEY NO.	PART NO.	DESCRIPTION
8	74610616	Bolt, Hex 3/8-24 x 1
9	4460J	Tine, Outer, R.H.
10	132728	Assembly, Hub and Plate, R.H.
11	6555J	Tine, Inner, R.H.

**NOTE:** All component dimensions given in U.S. inches.  
1 inch = 25.4 mm

# REPAIR PARTS

## TILLER - - MODEL NUMBER 917.293583

### DECALS

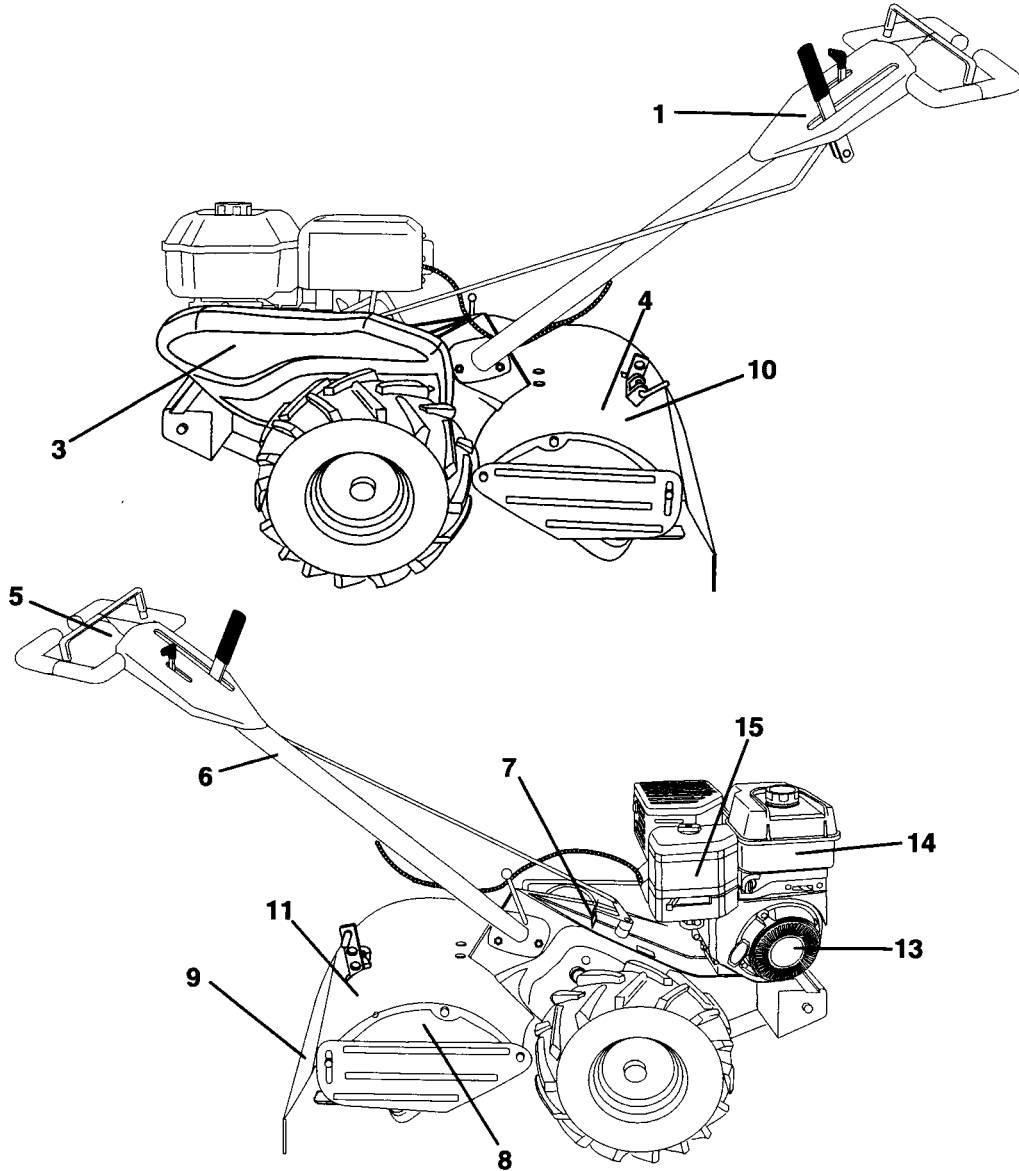

KEY NO.	PART NO.	DESCRIPTION
1	178976	Decal, Logo, Control Panel
3	176735	Decal, Logo, Belt Guard
4	166133	Decal, Description
5	137282	Decal, Control, Tine
6	159877	Decal, Hand Placement
7	102180X	Decal, Shift Indicator
8	157984	Decal, Tine Shield, Counter Rotating Tines
9	176557	Decal, Warning 4-Sym
10	168260	Decal, Tine Depth Stake
11	145437	Decal, Europe Stand CE
13	171078	Decal, Rewind
14	167156	Decal, Craftsman IC
15	171079	Decal, Intek
--	182552	Manual, Operator's (Euro)
--	182553	Manual, Operator's (Scand)
--	186827	Manual, Repair Parts



# REPAIR PARTS

TILLER - - MODEL NUMBER 917.293583

ENGINE, BRIGGS & STRATTON -- MODEL NUMBER 120402, TYPE NO. 0213-E1

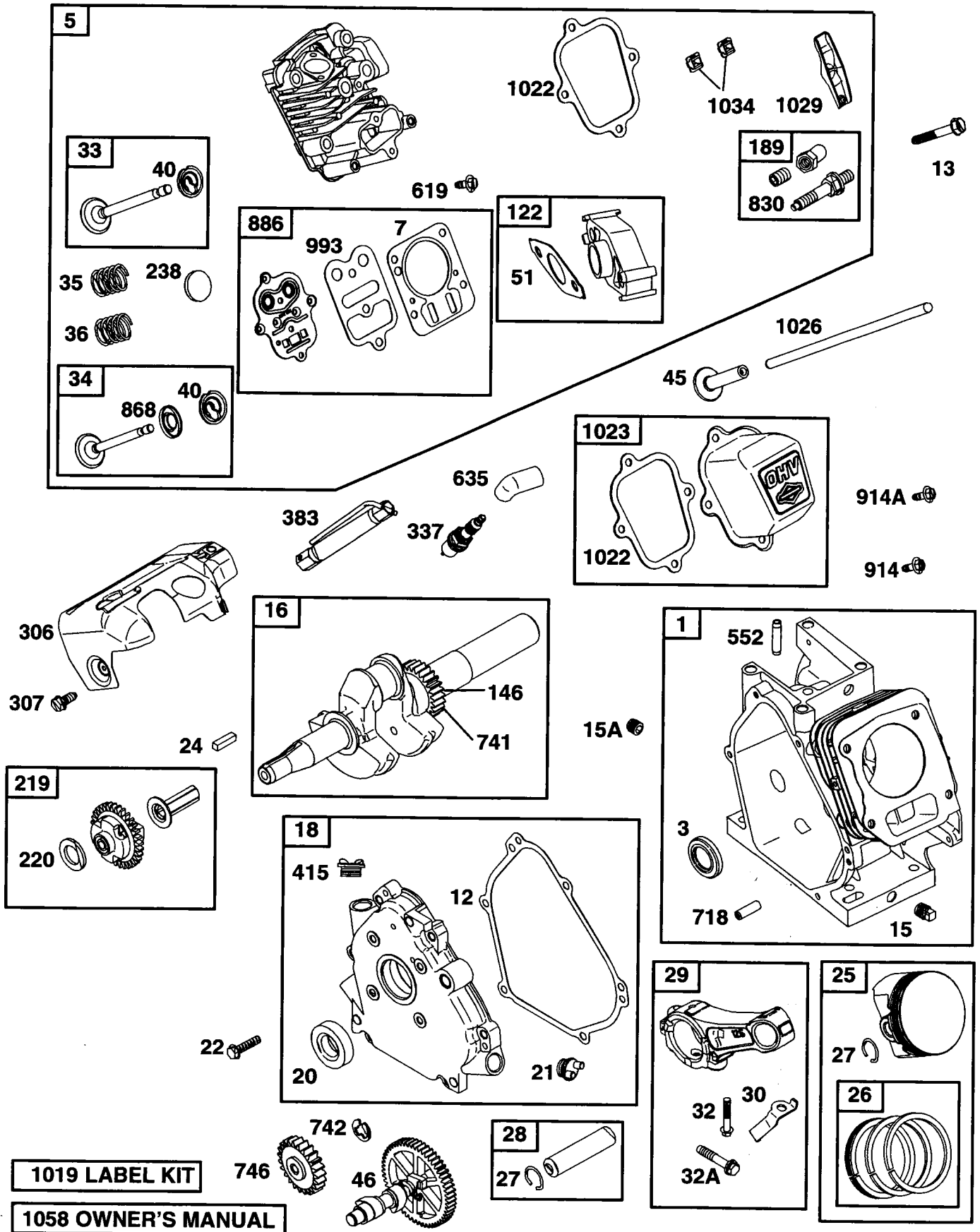

# REPAIR PARTS

TILLER - - MODEL NUMBER 917.293583

ENGINE, BRIGGS & STRATTON -- MODEL NUMBER 120402, TYPE NO. 0213-E1

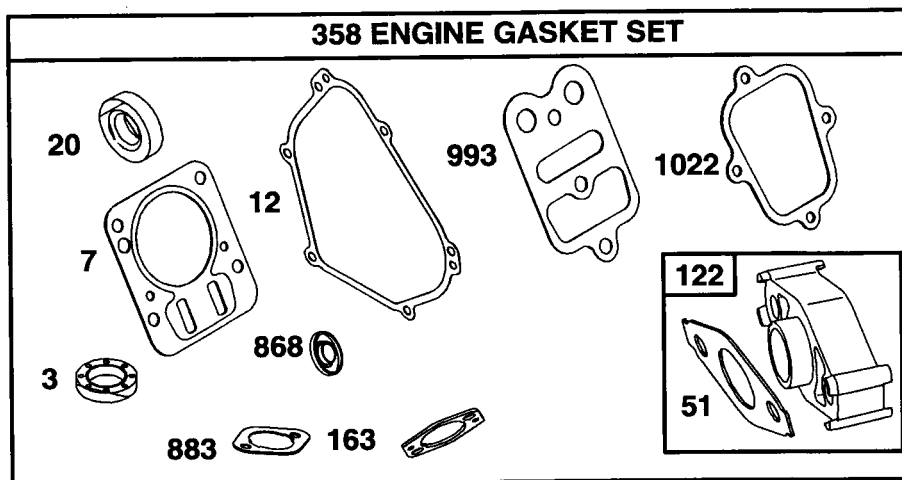
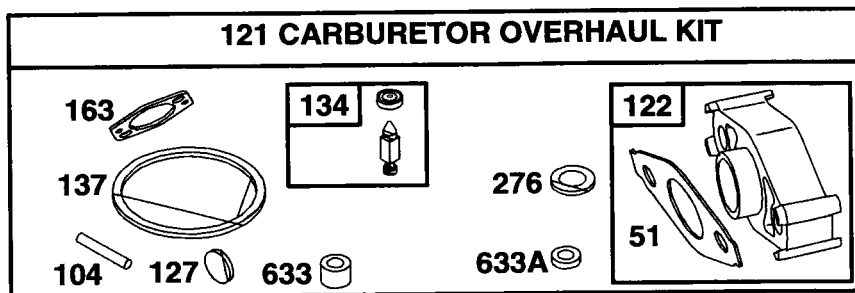
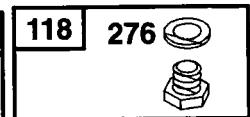
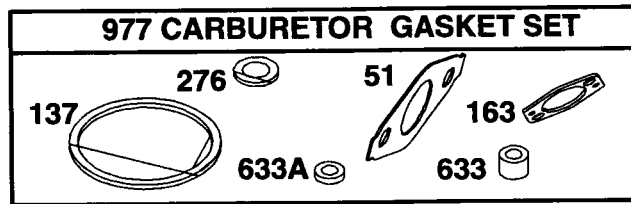
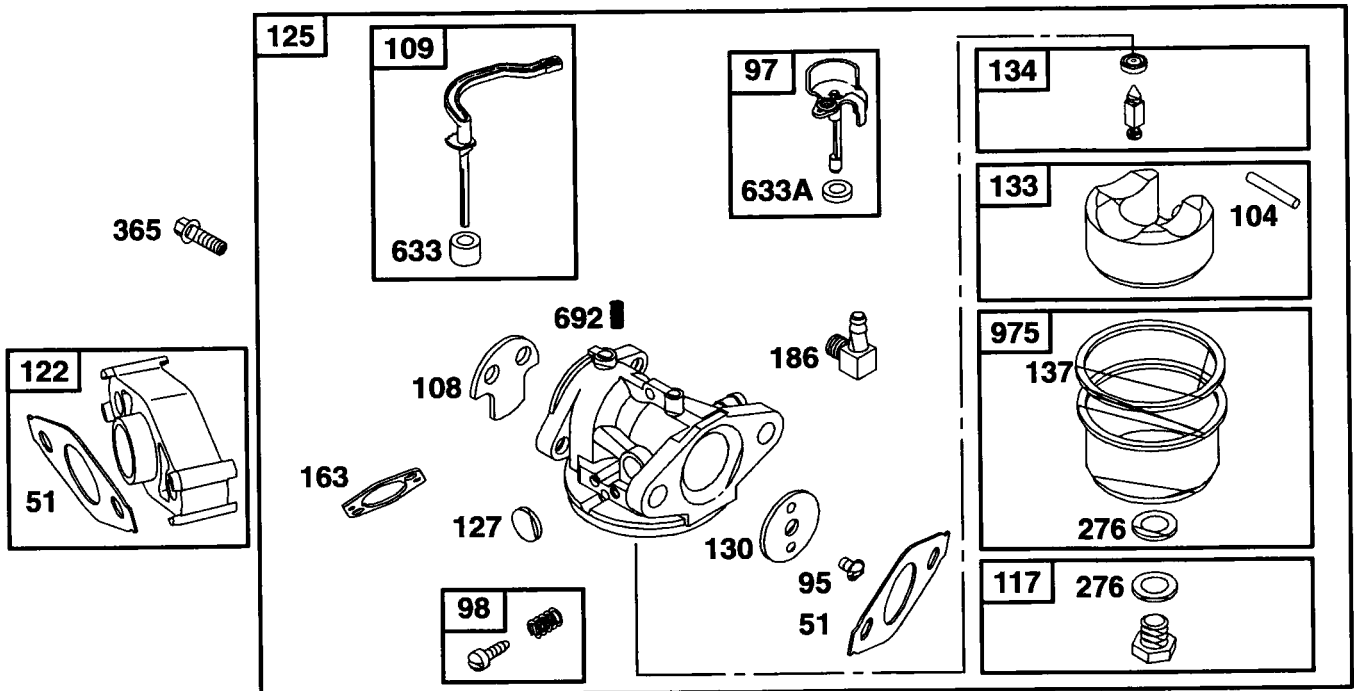

# REPAIR PARTS

TILLER - - MODEL NUMBER 917.293583

ENGINE, BRIGGS & STRATTON -- MODEL NUMBER 120402, TYPE NO. 0213-E1

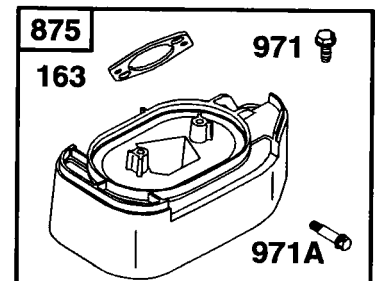
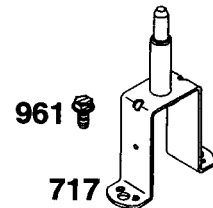
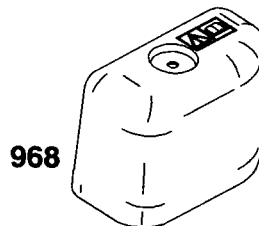
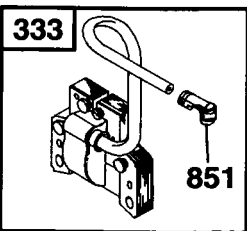
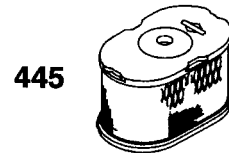
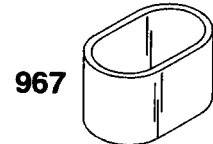
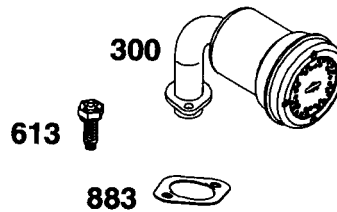
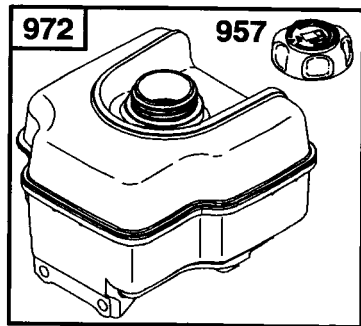
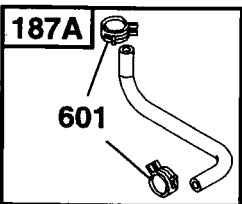
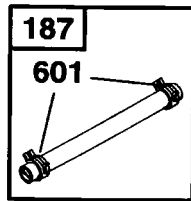
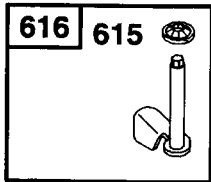
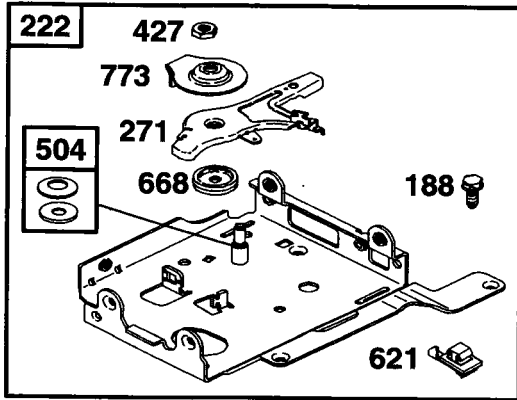
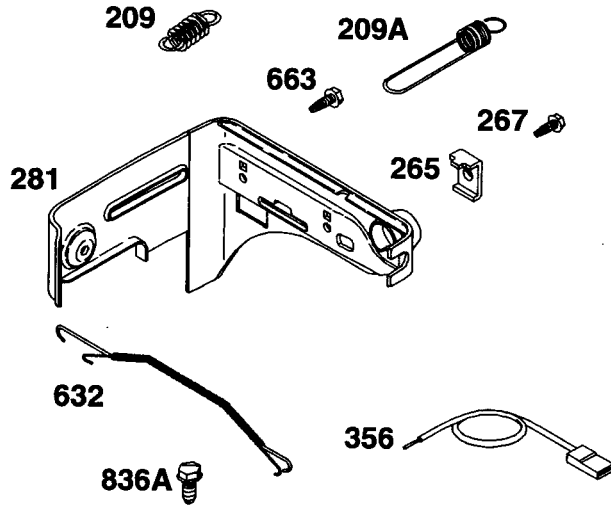
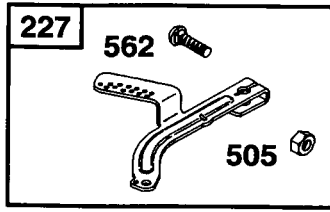

# REPAIR PARTS

TILLER - - MODEL NUMBER 917.293583

ENGINE, BRIGGS & STRATTON -- MODEL NUMBER 120402, TYPE NO. 0213-E1

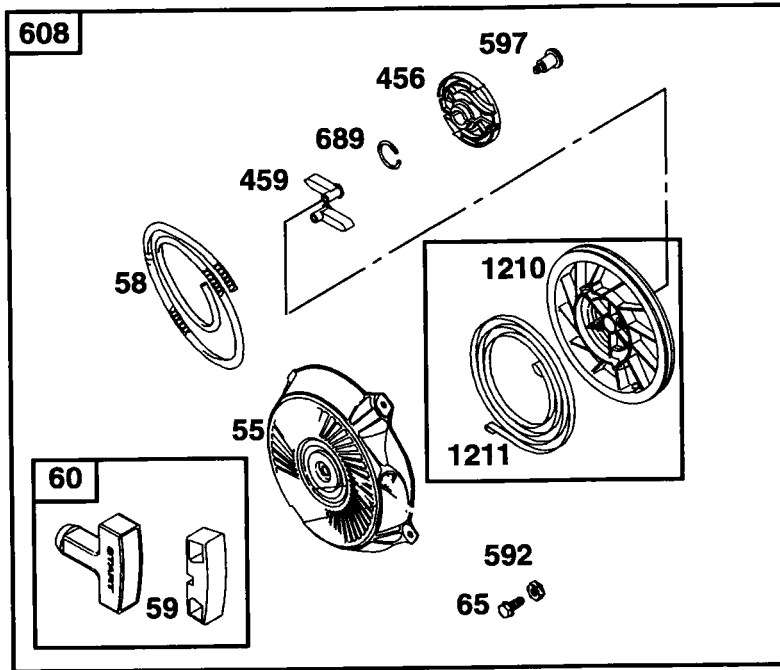

## 1036 EMISSIONS LABEL

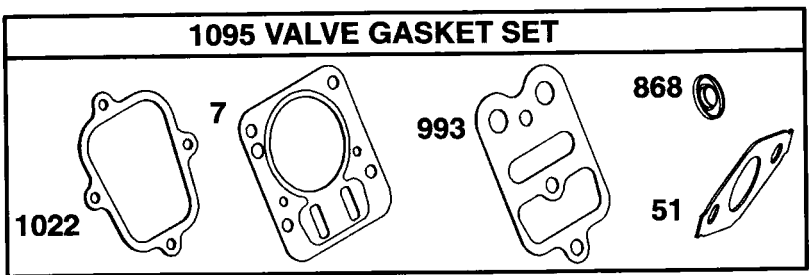
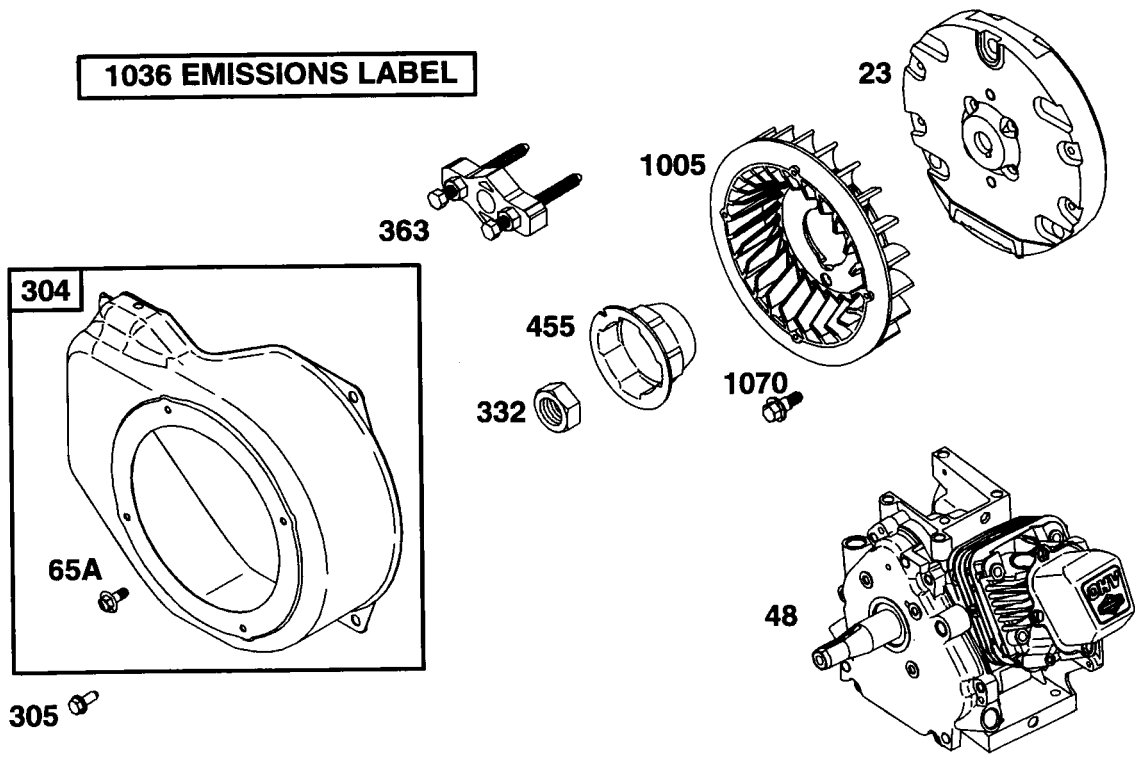

# REPAIR PARTS

## TILLER - - MODEL NUMBER 917.293583

### ENGINE, BRIGGS & STRATTON -- MODEL NUMBER 120402, TYPE NO. 0213-E1

KEY NO.	PART NO.	DESCRIPTION	KEY NO.	PART NO.	DESCRIPTION
1	693811	Cylinder Assembly	95	691636	Screw (Throttle Valve)
3	299819	• Seal-Oil (Magneto Side)	97	690024	Shaft-Throttle
5	693643	Head-Cylinder	98	398185	Kit-Idle Speed
7	695166	•+ Gasket-Cylinder Head	104	691242	∅ Pin-Float Hinge
11	693647	Tube-Breather	108	691182	Valve-Choke
12	692549	• Gasket-Crankcase	109	693628	Shaft-Choke
13	691137	Screw (Cylinder Head)	117	690048	Jet-Main (Standard)
15	691686	Plug-Oil Drain	118	498977	Jet-Main (High Altitude)
15A	691682	Plug-Oil Drain	121	695157	Kit-Carburetor Overhaul
16	693887	Crankshaft	122	693749	• ∅ Spacer-Carburetor
18	694466	Cover-Crankcase	125	693518	Carburetor
20	692550	• Seal-Oil (PTO Side)	127	691739	∅ Plug-Welch
21	281658	Cap-Oil Fill	130	691181	Valve-Throttle
22	692551	Screw (Engine Sump)	133	398187	Float-Carburetor
23	692987	Flywheel	134	398188	∅ Kit-Needle/Seat
24	222698	Key-Flywheel	137	693981	∅ ‡ Gasket-Float Bowl
25	690021	Piston Assembly (Standard)	146	690979	Key-Timing
	694167	Piston Assembly (.010" O.S.)	163	693458	Gasket-Air Cleaner
	694168	Piston Assembly (.020" O.S.)	186	692317	Connector-Hose
	694169	Piston Assembly (.030" O.S.)	187	691050	Line-Fuel (Cut to Required Length)
26	499631	Ring Set-Piston (Standard)	187A	692601	Line-Fuel (Molded)
	692785	Ring Set-Piston (.010" O.S.)	188	690877	Screw (Control Bracket)
	692786	Ring Set-Piston (.020" O.S.)	189	694543	Ball-Rocker Arm
	692787	Ring Set-Piston (.030" O.S.)	190	692127	Screw (Fuel Tank)
27	691866	Lock-Piston Pin	209	691278	Spring-Governor
28	499423	Pin-Piston	209A	692571	Spring-Governor
29	690124	Rod-Connecting	219	693578	Gear-Governor
30	692562	Dipper-Connecting Rod	220	691724	Washer (Governor Gear)
32	691664	Screw (Connecting Rod)	222	694253	Bracket-Control
32A	695759	Screw (Connecting Rod)	227	692573	Control Lever-Governor
33	499642	Valve-Exhaust	238	691300	Cap-Valve
34	499641	Valve-Intake	265	691024	Clamp-Casing
35	691304	Spring-Valve (Intake)	267	692577	Screw (Casing Clamp)
36	691304	Spring-Valve (Exhaust)	271	694256	Lever-Control
40	692194	Retainer-Valve	276	271716	∅ ‡ Sealing Washer
45	690977	Tappet-Valve	281	694252	Panel-Control
46	693404	Camshaft	300	693593	Muffler
48	-----	Short Block (120402-0194-E2 Replacement Engine)	304	693621	Housing-Blower
			305	690960	Screw (Blower Housing)
51	692555	•∅ ‡+ Gasket-Intake			
55	691422	Housing-Rewind Starter			
58	693389	Rope-Starter (Cut to Required Length)			
59	805957	Insert-Grip			
60	715257	Grip-Starter Rope			
65	690837	Screw (Blower Housing)			
65A	692608	Screw (Rewind Starter)			

RPM Settings: Low Speed: 1900-2100  
High Speed: 3000-3200

- Included in Engine Gasket Set, Key. No. 358
- ∅ Included in Carburetor Overhaul Kit, Key. No. 121
- ‡ Included in Carburetor Gasket Set, Key. No. 977
- + Included in Valve Gasket Set, Key. No. 1095

**NOTE:** All component dimensions given in U.S. inches 1 inch = 25.4 mm

# REPAIR PARTS

## TILLER - - MODEL NUMBER 917.293583

### ENGINE, BRIGGS & STRATTON -- MODEL NUMBER 120402, TYPE NO. 0213-E1

KEY NO.	PART NO.	DESCRIPTION	KEY NO.	PART NO.	DESCRIPTION
306	693610	Shield-Cylinder	746	692566	Gear-Idler
307	690345	Screw (Cylinder Shield)	773	694258	Retainer
332	690662	Nut (Flywheel)	830	694544	Stud (Rocker Arm)
333	695711	Armature-Magneto	832	693583	Guard-Muffler
334	691061	Screw (Armature Magneto)	836	690661	Screw (Muffler Guard)
337	491055	Spark Plug	836A	693624	Screw (Muffler Guard)
356	692390	Wire-Stop	851	493880	Terminal-Sparkplug
358	695155	Engine Gasket Set	868	692044	*+ Seal-Valve
363	19069	Flywheel Puller	875	693459	Base-Air Cleaner
365	692568	Screw (Carburetor)	883	691893	*+ Gasket-Exhaust
383	19374	Wrench-Spark Plug	886	696268	Gasket Kit-Cylinder Head/ Plate
415	693463	Plug	914	692198	Screw (Rocker Cover)
427	694255	Nut (Control Bracket)	914A	692557	Screw (Rocker Cover)
445	697029	Filter-Air Cleaner Cartridge	957	694261	Cap-Fuel Tank
455	692591	Cup-Flywheel	958	692586	Valve-Fuel Shut Off
456	692299	Plate-Pawl Friction	961	693598	Screw (Air Cleaner Bracket)
467	691668	Knob-Air Cleaner	967	273356	Filter-Pre Cleaner
459	281505	Pawl-Ratchet	968	693460	Cover-Air Cleaner
504	694254	Washer Set	971	690349	Screw (Air Cleaner Base)
505	691251	Nut (Governor Control Lever)	971A	691693	Screw (Air Cleaner Base)
552	692346	Bushing-Governor Crank	972	694260	Tank-Fuel
562	691112	Bolt (Governor Control Lever)	975	493640	Bowl-Float
592	690800	Nut (Rewind Starter)	977	695156	Set-Carburetor Gasket
597	691696	Screw (Pawl Friction Plate)	993	694088	*+ Gasket-Cylinder Head Plate
601	95162	Clamp-Hose	1005	692592	Fan-Flywheel
608	693394	Starter-Rewind	1019	694852	Kit-Label
613	691665	Screw (Muffler)	1022	691890	*+ Gasket-Rocker Cover
615	692576	Retainer-Governor Shaft	1023	499924	Cover-Rocker
616	692547	Crank-Governor	1026	693517	Rod-Push
619	691108	Screw (Cylinder Head Plate)	1029	691230	Arm-Rocker
621	692310	Switch-Stop	1034	691343	Guide-Push Rod
632	693408	Spring/Link-Mechanical Governor	1036	697004	Label-Emissions
633	693867	Ø‡ Seal-Choke/Throttle Shaft	1058	275092	Owner's Manual
633A	691321	Ø‡ Seal-Throttle Shaft	1070	692590	Screw (Flywheel Fan)
635	692076	Boot-Sparkplug	1095	695289	Set-Valve Gasket
663	694593	Screw (Control Panel)	1210	498144	Assembly-Pulley/Spring (Pulley)
668	694257	Spacer	1211	498144	Assembly-Pulley/Spring (Spring)
676	393757	Deflector-Muffler			
677	690661	Screw (Muffler Deflector)			
689	691855	Spring-Friction			
692	690572	Spring-Detent			
717	693462	Bracket-Air Cleaner			
718	690959	Pin-Locating			
741	692565	Gear-Timing			
742	692564	Retainer-E Ring			

RPM Settings: Low Speed: 1900-2100  
High Speed: 3000-3200

- Included in Engine Gasket Set, Key. No. 358
- Ø‡ Included in Carburetor Overhaul Kit, Key. No. 121
- ‡ Included in Carburetor Gasket Set, Key. No. 977
- + Included in Valve Gasket Set, Key. No. 1095

**NOTE:** All component dimensions given in U.S. inches 1 inch = 25.4 mm