

# REPAIR PARTS MANUAL

MODEL NO. 250420

Lawn Tractor

13,5 38"



# HOW TO USE THIS MANUAL

This manual is designed to provide the customer with a means to identify the parts on his/her tractor when ordering repair parts. The illustrations may or may not represent the actual assemblies; therefore, it is not recommended to use this manual as a guide to assemble or disassemble the tractor. Some hardware and parts are drawn larger in order to more readily identify them.

Each tractor has its own model number.

The model number for your tractor can be found on the fender under the seat.

When ordering parts, always give the following information:

- Product - "Tractor"
- Model Number - "250420"
- Part Number
- Part Description

## TABLE OF CONTENTS

<b>SCHEMATIC.....</b>	<b>3</b>
<b>ELECTRICAL.....</b>	<b>4-5</b>
<b>CHASSIS.....</b>	<b>6-7</b>
<b>DRIVE.....</b>	<b>8-9</b>
<b>STEERING.....</b>	<b>10-11</b>
<b>SEAT.....</b>	<b>12</b>
<b>DECALS.....</b>	<b>13</b>
<b>ENGINE.....</b>	<b>14-15</b>
<b>MOWER LIFT.....</b>	<b>16-17</b>
<b>MOWER DECK.....</b>	<b>18-19</b>
<b>TRANSAXLE.....</b>	<b>20-21</b>
<b>ENGINE BREAKDOWN.....</b>	<b>22-27</b>
<b>WARRANTY.....</b>	<b>28</b>

# TRACTOR- -MODEL NO. 917. 250420

## SCHEMATIC

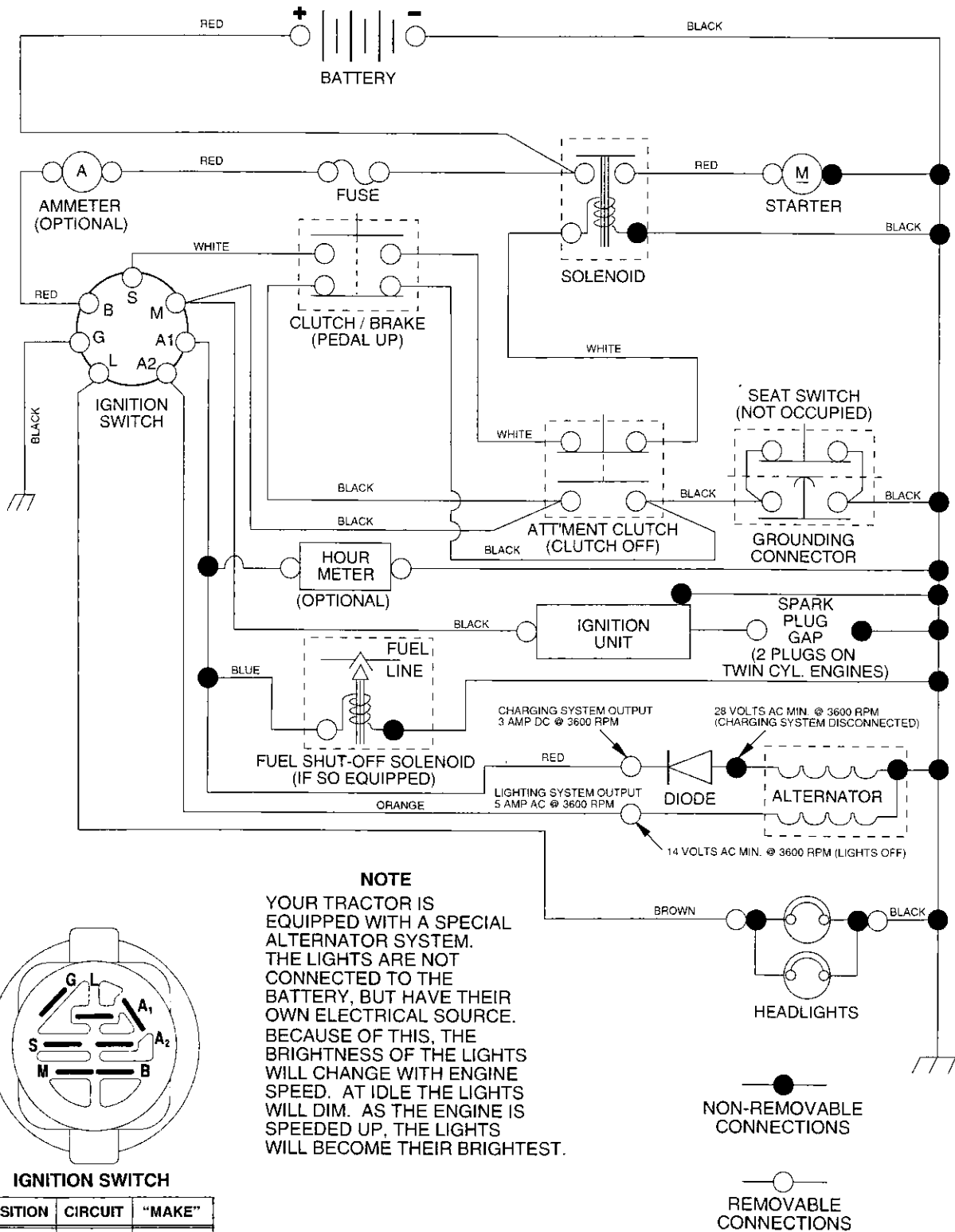

**NOTE**  
 YOUR TRACTOR IS EQUIPPED WITH A SPECIAL ALTERNATOR SYSTEM. THE LIGHTS ARE NOT CONNECTED TO THE BATTERY, BUT HAVE THEIR OWN ELECTRICAL SOURCE. BECAUSE OF THIS, THE BRIGHTNESS OF THE LIGHTS WILL CHANGE WITH ENGINE SPEED. AT IDLE THE LIGHTS WILL DIM. AS THE ENGINE IS SPEEDED UP, THE LIGHTS WILL BECOME THEIR BRIGHTEST.

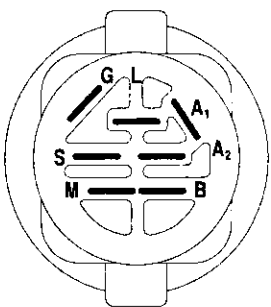

**IGNITION SWITCH**

POSITION	CIRCUIT	"MAKE"
OFF	M+G+A1	NONE
RUN/LIGHT	B+A1	A2+L
RUN	B+A1	NONE
START	B + S + A1	NONE

**WIRING INSULATED CLIPS**  
**NOTE:** IF WIRING INSULATED CLIPS WERE REMOVED FOR SERVICING OF UNIT, THEY SHOULD BE REPLACED TO PROPERLY SECURE YOUR WIRING.



# REPAIR PARTS

## TRACTOR- -MODEL NO. 917. 250420

### ELECTRICAL

KEY NO.	PART NO.	DESCRIPTION
1	144925	Battery 12 VOLT 25 AMP
2	74760412	Bolt Hex Hd 1/4-20unc x 3/4
8	156417	Case Battery
16	153664	Switch, Interlock Push-In
21	166181	Harness Asm Light W/4152j
22	4152J	Bulb Light #1156
24	4799J	Cable Battery 6 Ga 11" red
25	146147	Cable Battery 6 Ga w/16 wire red
26	175158	Fuse 20 AMP
27	73510400	Nut, Keps Hex 1/4-20 UNC
28	4207J	Cable Ground 6 Ga 12" black
29	121305X	Switch Plunger Nc Gray
30	175566	Switch Ign
33	140403	Key Ign Molded Craftsman
40	170217	Harness Ign
41	71110408	Bolt Blk. Fin Hex 1/4-20 Unc x 1/2
42	131563	Cover Terminal Red
43	175141	Solenoid
48	140844	Adapter Ammeter
52	141940	Protection Wire Loop

**NOTE:** All component dimensions give in U.S. inches  
1 inch = 25.4 mm

# REPAIR PARTS

TRACTOR- -MODEL NO. 917. 250420

## CHASSIS AND ENCLOSURES

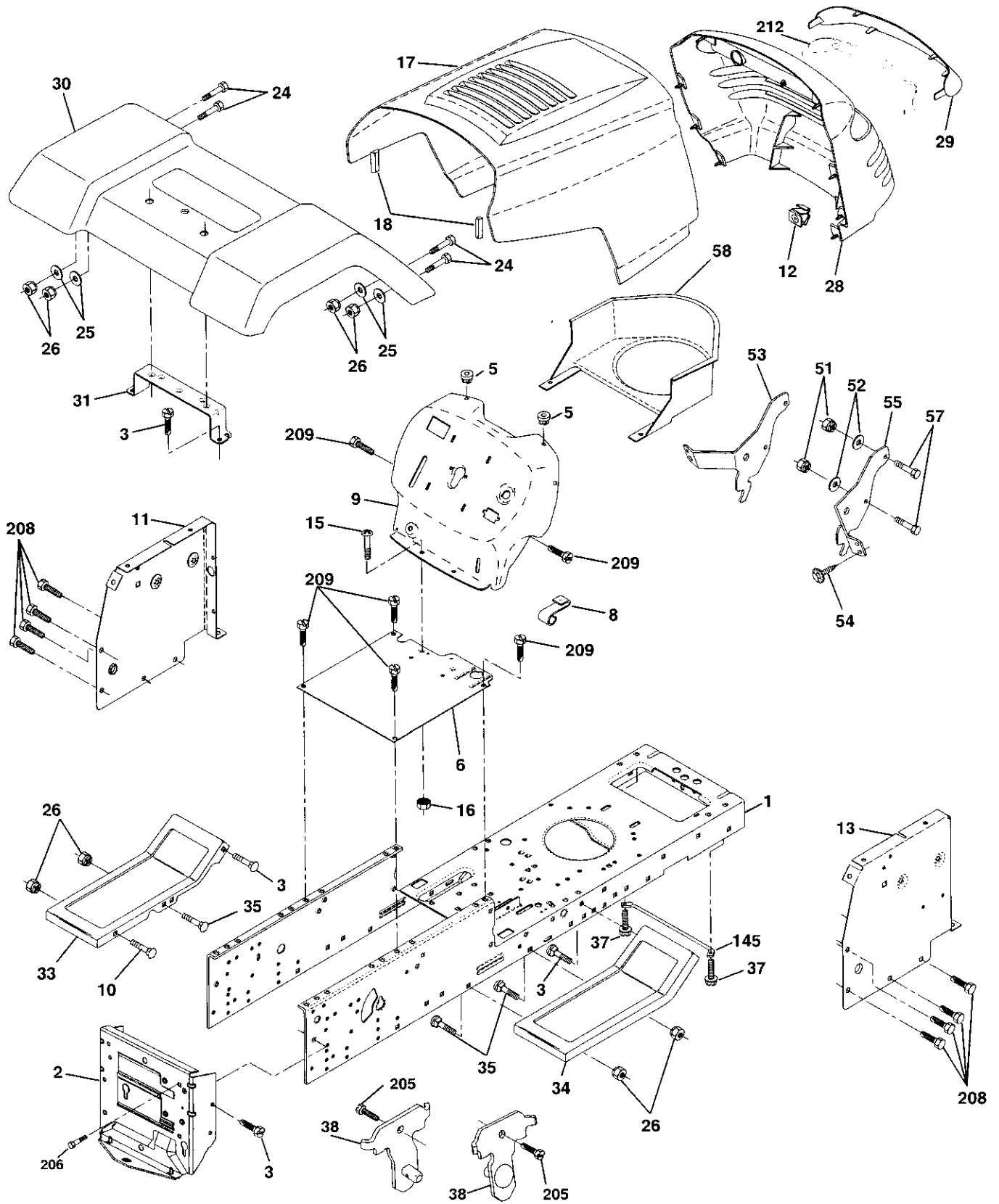

# REPAIR PARTS

## TRACTOR- -MODEL NO. 917. 250420

### CHASSIS AND ENCLOSURES

KEY NO.	PART NO.	DESCRIPTION
1	169831	Chassis
2	176554	Drawbar
3	17060612	Screw 3/8-16 x 3/4
5	155272	Bumper Hood/Dash
6	155924X014	Saddle
8	126471X	Clip
9	168347X011	Dash
10	STD533710	Bolt, Carriage 3/8-16 x 3/4
11	155927	Panel, Dash, L.H.
12	145660	Clip Tinnerman Grille P/L
13	172107X010	Panel, Asm. SLKSCR Dash R.H.
15	74180512	Screw Mach Thrd 5/16-18 UNC 3/4
16	73510500	Nut Keps 5/16-18 UNC
17	159639X558	Hood Assembly
18	126938X	Bumper Hood
24	74780616	Bolt Fin Hex 3/8-16 UNC x 1 Gr. 5
25	19131312	Washer 13/32 x 13/16 x 12 Gauge
26	STD541437	Nut, Lock Hex W/Ins. 3/8-16 UNC
28	150407	Grille w/Lens Asm.
29	150209X599	Lens, Grille
30	169465X558	Fender
31	136619	Bracket, Fender Support
33	105476X558	Footrest LH
34	105475X558	Footrest RH
35	72140608	Bolt RDHD Sqnk 3/8-16 UNC x 1
37	17490508	Screw Thdrol 5/16-18 x 1/2 TYT
38	169834	Bracket Asm Pivot
51	73800400	Nut Lock w/Insert 1/4-20 UNC
52	19091416	Washer 9/32 x 7/8 x 16 Ga.
53	144697	Bracket Grille LH
54	161464	Screw Hex WSHD 8-18 x 7/8
55	144696	Bracket Grille RH
57	STD522507	Bolt, Fin Hex 1/4-20 UNC x .75
58	150127	Duct Air Engine
145	156524	Rod Pivot Chassis/Hood
205	17490608	Screw Hexwsh Thdrol 3/8-16 x 1/2
206	170165	Bolt Shoulder 5/16-18 TT
208	17670608	Screw Thdrol 3/8-16 x 1/2
209	17000612	Screw Hexwsh Thdrl 3/8-16 x 3/4
212	156494	Insert Lens Reflective
--	5479J	Plug, Button

**NOTE:** All component dimensions give in U.S. inches  
1 inch = 25.4 mm

# REPAIR PARTS

TRACTOR- -MODEL NO. 917. 250420

## DRIVE

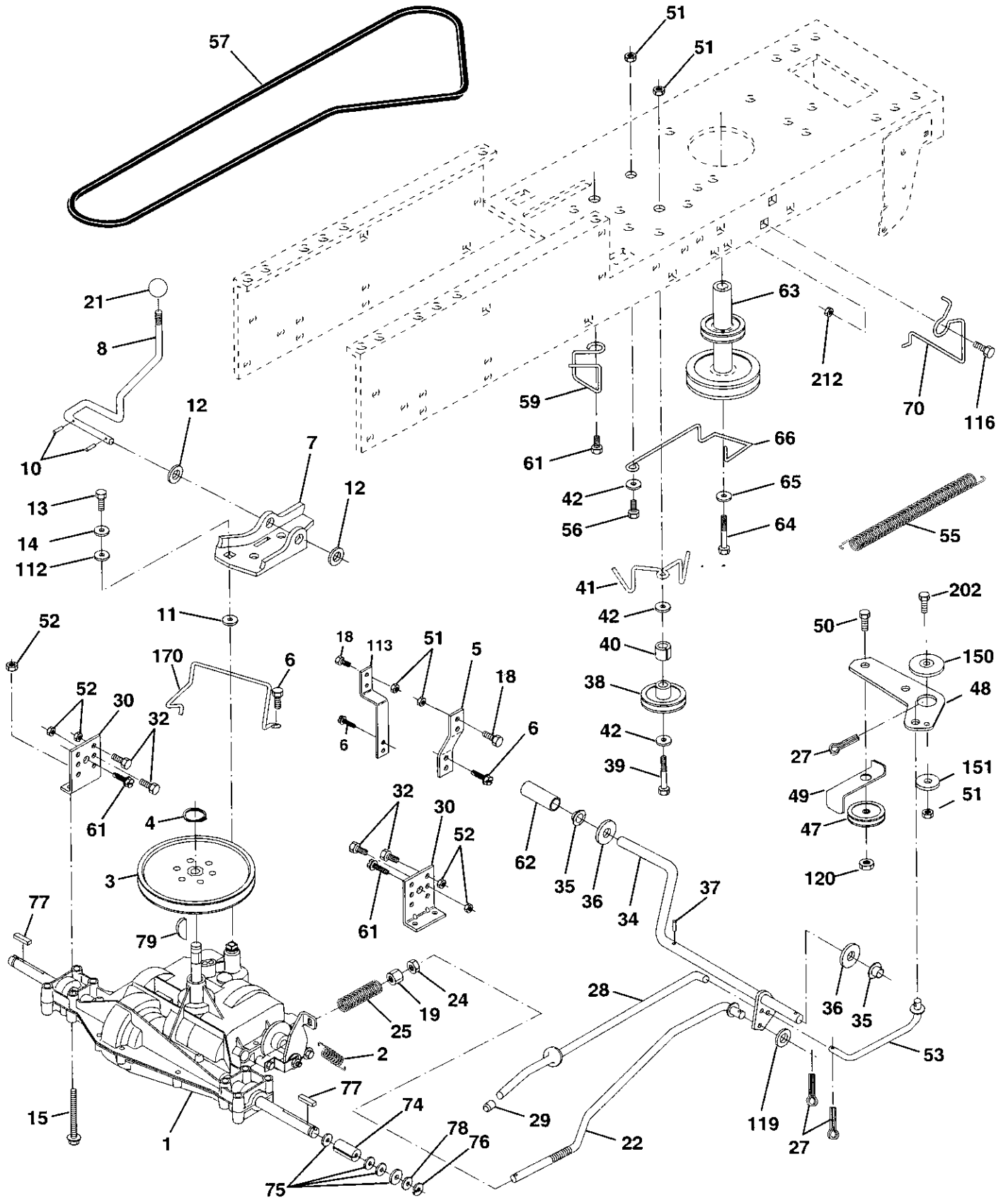



# REPAIR PARTS

## TRACTOR- -MODEL NO. 917. 250420

### DRIVE

KEY NO.	PART NO.	DESCRIPTION	KEY NO.	PART NO.	DESCRIPTION
1	-----	Transaxle Dana D4360-139 (Order parts from transaxle Manufacturer)	47	127783	Pulley Idler V Groove Plastic
2	146682	Spring Return Brake T/a Zinc	48	154407	Bellcrank Asm. Clutch
3	123666X	Pulley Transaxle 18/20" tires	49	123205X	Retainer Belt Style Spring
4	12000028	Ring Retainer # 5100-62	50	74760624	Bolt Hex Hd 3/8-16unc x1-1/2
5	121520X	Strap Torque 30 Degrees	51	73680600	Nut Crownlock 3/8-16 UNC
6	17060512	Screw 5/16-18 x 3/4	52	73680500	Nut Crown Lock 5/16-18
7	162240	Bracket Saddle Shift T/a	53	105710X	Link Clutch 7 66
8	131679	Rod Shf Sdl LYYT Str Blk	55	105709X	Spring Return Clutch 6 75
10	76020416	Pin Cotter 1/8 x 1 Cad	56	74760620	Bolt Fin Hex 3/8-16 unc x 1-1/4
11	105701X	Washer Plate 388 Sq Hole	57	160855	V-Belt Gd Drive 9530
12	19151216	Washer 15/32 x 3/4 x 16ga	59	169691	Keeper Belt Centerspan
13	74550412	Bolt 1/4-28unf Gr8 W/Patch	61	17060612	Screw 3/8-16 x 3/4
14	10040400	Washer Lock Hvy Helical 1/4	62	8883R	Cover Pedal Blk Round
15	74490544	Bolt Hex Flghd 5/16-18 x Gr. 5	63	140186	Pulley Eng Cl Mech 38deg
18	74780616	Bolt Fin Hex 3/8-16 UNC x 1 Gr. 5	64	71170764	Bolt Hex 7/16-20 x 4 Gr 5
19	73800600	Nut Lock Hex W/Ins. 3/8-16 Unc	65	10040700	Washer Lock Hlcl Spr 7/16
21	106933X	Knob Rd 1/2-13 Plstc Thds	66	154778	Keeper Belt Engine FP
22	130804	Rod Brake Blk Zinc 26 840	70	134683	Guide Belt Mower Drive RH
24	73350600	Nut Hex Jam 3/8-16 Unc	74	109502X	Spacer Axle
25	106888X	Spring Rod Brake 2 00 Zinc	75	121749X	Washer 25/32 x 1-1/4 x16 Ga
26	19131016	Washer 13/32 x 5/8 x 16 Ga	76	12000001	E-ring #5133-75
27	76020412	Pin Cotter 1/8 x 3/4 Cad	77	123583X	Key Square 2 0 x 1845/ 1865
28	145204	Rod Brake Parking Lt/Yt	78	121748X	Washer 25/32 x1-5/8 x 16 Ga
29	71673	Cap Brake Parking	79	2228M	Key Woodruff
30	174973	Bracket Mtg Transaxle	112	19091210	Washer 9/32 x 3/4 x 10 Ga
32	74760512	Bolt Hex Hd 5/16-18unc x 3/4	113	127285X	Strap Torque LH LT
34	155071	Shaft Asm Pedal Foot	116	72140608	Bolt RDHD Sqnk 3/8-16 UNC x 1
35	120183X	Bearing Nylon Blk 629 Id	119	19131016	Washer 13/32 x 5/8 x 16 Ga.
36	19211616	Washer 21/32 x 1 x 16 Ga	120	73900600	Nut Lock Flg. 3/8-16 UNC
37	1572H	Pin Roll 3/16 x 1"	150	165850	Bushing Bellcrank GRD Drive
38	131494	Pulley Idler Flat	151	19133210	Washer 13/32 x 2 x 10 Ga.
39	74760644	Bolt Fin Hex 3/8-16 UNC x 2-3/4 Gr. 5	170	173898	Keeper Belt Transaxle Gear
40	4470J	Spacer Split 395 x 59 Bzp	202	72110612	Bolt Carr. Sh 3/8-16 x 1-1/2 Gr. 5
41	165838	Keeper Belt Idler	212	145212	Nut Hex Flange Lock
42	19131312	Washer 13/32 x 13/16 x 12 Ga			

**NOTE:** All component dimensions given in U. S. inches 1 inch = 25.4 mm



# REPAIR PARTS

## TRACTOR- -MODEL NO. 917. 250420

### STEERING ASSEMBLY

KEY NO.	PART NO.	DESCRIPTION
1	139768	Steering Wheel
2	156483	Front Axle Assembly
3	157473	Spindle Assembly, L.H.
4	169839	Spindle Assembly, R.H.
5	6266H	Bearing, Race, Thrust, Hardened
6	121748X	Washer 25/32 x 1-5/8 x 16 Gauge
7	19272016	Washer 27/32 x 1-1/4 x 16 Gauge
8	12000029	Ring, Klip
9	3366R	Bearing, Steering Column
10	169832	Link, Drag
11	STD551137	Washer, Lock
13	136518	Spacer, Bearing, Front Axle
15	145212	Nut Lock Hex Flange
17	156546	Shaft Assembly, Steering
18	57079	Washer, Thrust .515 x .750 x .033
19	160395	Support, Shaft
22	165857	Screw Hex WSH HDTorx
23	165851	Pittman Shaft Assembly
25	154406	Bracket, Steering
26	126847X	Bushing, Link, Drag
27	136874	Gear, Sector
28	19131416	Washer 13/32 x 7/8 x 16 Gauge
29	17060612	Screw 3/8-16 x 3/4
30	STD561210	Pin
32	130465	Rod, Tie
36	155099	Bushing, Steering
37	152927	Screw TT #10-32 x 5 x 3/8 Flange
38	139769	Cap Wheel Steer OPP Blk
39	19133812	Washer 13/32 x 2-3/8 x 12 Gauge
40	STD541537	Nut Lock Center 3/8-24 UNF
41	100711L	Adaptor, Steering Wheel
42	145054X428	Boot, Steering Dash P/L Mtl Blk
43	121749X	Washer 25/32 x 1-1/4 x 16 Gauge
44	153720	Extension Steering Non-Adjust
46	121232X	Cap, Spindle
47	6855M	Fitting, Grease
51	STD541431	Nut Lock Hx W/Ins 5/16-18 UNC
54	74780520	Bolt Fin Hex 5/16-18 UNC x 1-1/4
62	167902	Kit, Steering Assembly, Service
63	STD523710	Bolt Fin Hex 3/8-16 unc. x 1 Gr. 5
65	160367	Spacer Brace Axle
66	154404	Bearing Arm Pittman
67	72140618	Bolt Rdhd Sq 3/8-16 x 2-1/4
68	169827	Brace Axle
79	19132012	Washer 13/32 x 1-1/4 x 12 Ga.
80	74950612	Bolt Hex Nylon 3/8-16 x 3/4
82	169835	Bracket Susp Chassis Front
85	133835	Fastener Christmas Tree

**NOTE:** All component dimensions given in U.S. inches 1 inch = 25.4 mm

# REPAIR PARTS

## TRACTOR- -MODEL NO. 917.250420

### SEAT ASSEMBLY

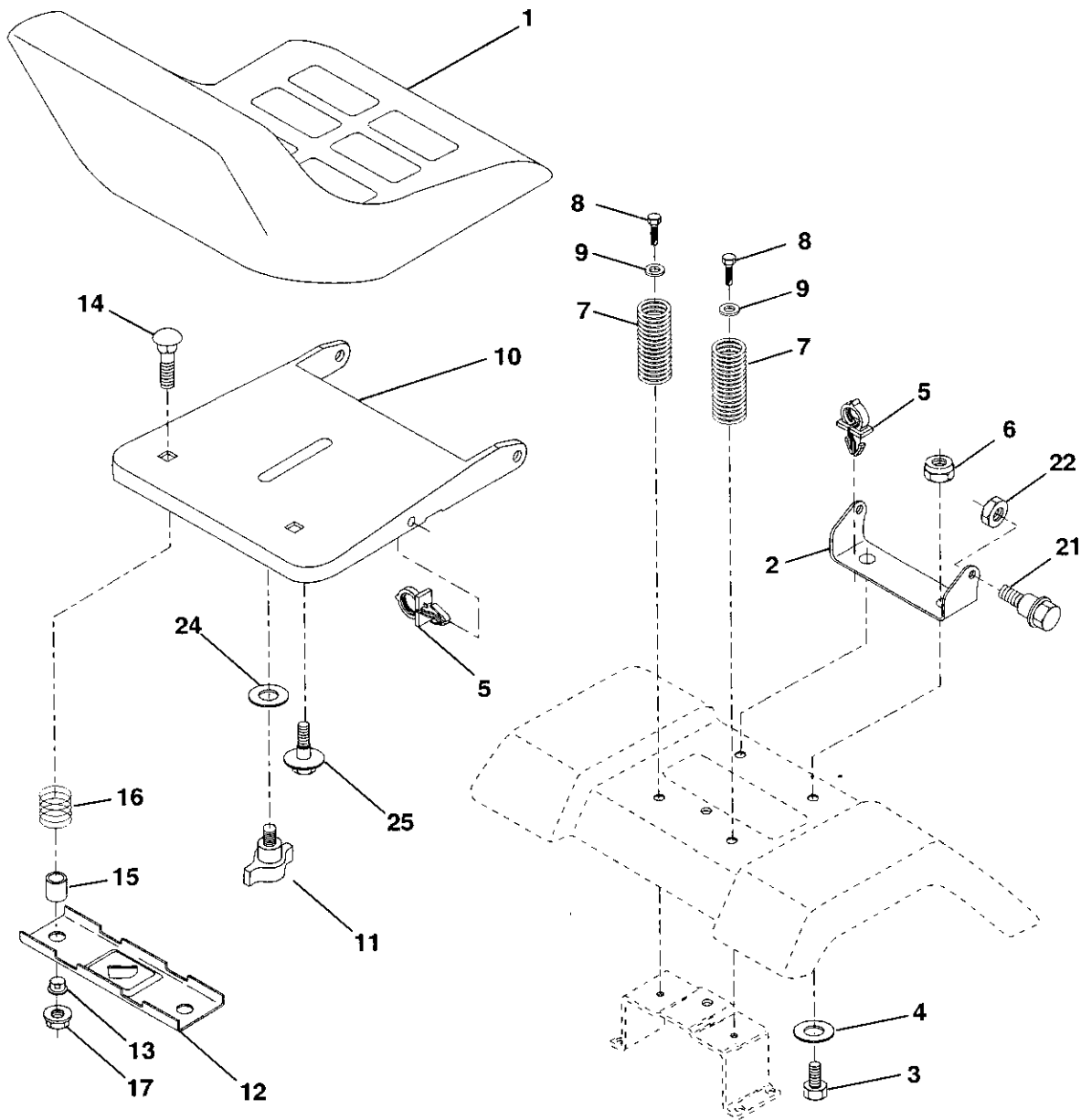

KEY NO.	PART NO.	DESCRIPTION
1	127427	Seat
2	140551	Bracket Pnt Pivot Seat (blk )
3	71110616	Bolt Fin Hex 3/8-16unc X 1
4	19131610	Washer 13/32 X 3/4 X 10 Ga
5	145006	Clip Push In Hinged
6	STD541437	Nut Hex Lock w/lns 3/8-16 Unc
7	124181X	Spring Seat Cprsn 2 250 Blk Zi
8	17000616	Screw 3/8-16 X 1 -1/2
9	19131614	Washer 13/32 X 1 X 14 Ga
10	174894	Pan Pnt Seat (blk )
11	166369	Knob Seat
12	121246X	Bracket Pnt Mounting Switch

KEY NO.	PART NO.	DESCRIPTION
13	121248X	Bushing Snap Blk Nyl 50 Id
14	72050412	Bolt Rdhd Sht Nk 1/4-20x1-1/2
15	134300	Spacer Split 28 X 96 Zinc
16	121250X	Spring Cprsn 1 27 Blk Pnt
17	123976X	Nut Lock 1/4 Lge Flg Gr 5 Zinc
21	171852	Bolt Shoulder 5/16-18 Unc-2A
22	STD541431	Nut Hex Lock w/lns 5/16-18
24	19171912	Washer 17/32 X 1-3/16 X 12 Ga
25	127018X	Bolt Shoulder 5/16-18 X 62

**NOTE:** All component dimensions given in U.S. inches  
1 inch = 25.4 mm

# REPAIR PARTS

TRACTOR- -MODEL NO. 917.250420

## DECALS

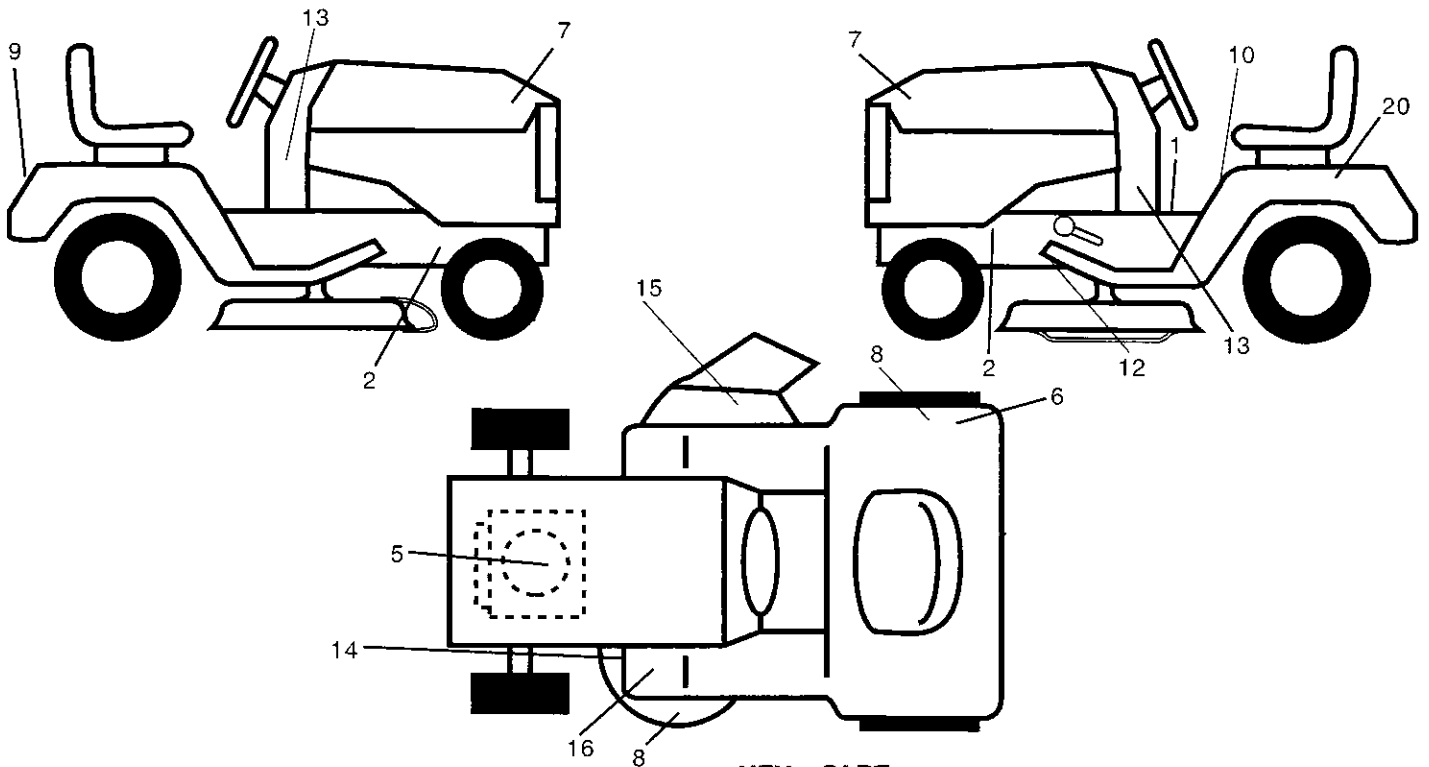

KEY NO.	PART NO.	DESCRIPTION
1	140837	Decal Brake Parking Saddle
2	159736	Decal Chassis Hot Muffler
5	176450	Decal, Hp Engine
6	126187X	Decal Certification
7	171704	Decal, Hood
8	145437	Decal CE
9	163204	Decal, Fender Craftsman
10	145498	Decal Read Owners Manual
12	146046	Decal, V-belt Dr Sch
13	177109	Decal, Dash, Panel

KEY NO.	PART NO.	DESCRIPTION
14	136832	Decal, V-belt Schematic
15	145494	Decal Cut Finger
16	159737	Decal Brake/Clutch
20	145005	Decal, Battery Dngr/Psn Eng
--	162598	Decal Drawbar Load Limit
--	138311	Decal, Lift Handle
--	165800X428	Pad, Footrest LH STLT
--	165799X428	Pad, Footrest RH STLT
--	177903	Manual, Oper (Euro)
--	177904	Manual, Oper (Scan)
--	177905	Manual Parts

## WHEELS & TIRES

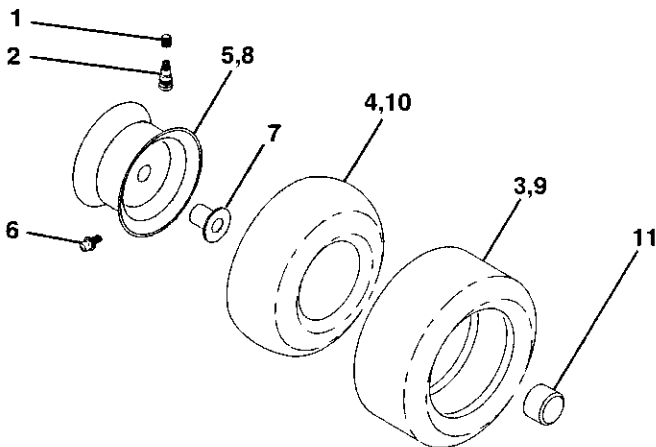

KEY NO.	PART NO.	DESCRIPTION
1	59192	Cap Valve Tire
2	65139	Stem Valve
3	106222X	Tire F Ts 15 X 6 0 - 6 Service
4	59904	Tube Inner Front #35060
5	106732X427	Rim Asm 6"front White Service
6	278H	Fitting Grease
7	9040H	Bearing Flange
8	106108X427	Rim Asm 8"rear White Service
9	124635X	Tire R Ts 18 X 8 5-8 Service
10	7152J	Tube Rear 9 5 X 8 Service
11	104757X428	Cap Axle Blk 1 50 X 1 00
--	144334	Sealant, Tire (10 oz. tube)

**NOTE:** All component dimensions given in U.S. inches  
1 inch = 25.4 mm

# REPAIR PARTS

TRACTOR- -MODEL NO. 917.250420

## ENGINE

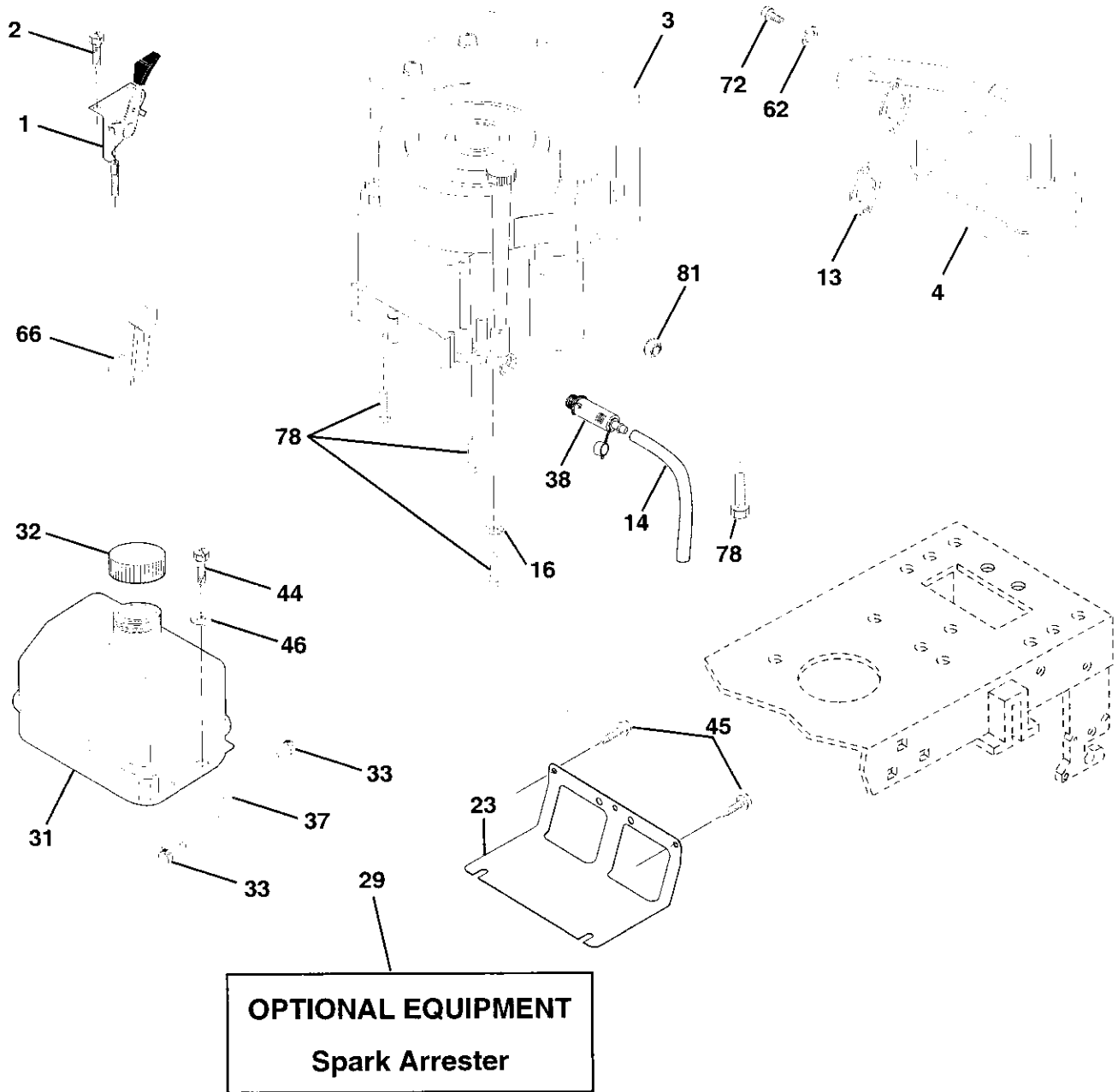

# REPAIR PARTS

## TRACTOR- -MODEL NO. 917.250420

### ENGINE

KEY NO.	PART NO.	DESCRIPTION
1	170549	Control Throttle/Choke
2	17720410	Screw Hex Thd Cut 1/4-20x5/8 T
3	-----	Engine (See Breakdown) Briggs Model 28R707-1147-E1
4	137348	Muffler
13	165291	Gasket 1 313 Id Tin Plated
14	148456	Tube Drain Oil
16	STD551237	Washer Lock Ext Tooth 3/8
23	169837	Shield BRN/DBR Guard
29	137180	Arrestor Spark
31	109202X	Tank Fuel 1 25 Fr
32	158990	Cap Asm Fuel W/sym Vented
33	123487X	Clamp Hose Bik
37	137040	Line Fuel 20"
38	148315	Plug Oil Drain
40	124028X	Bushing Snap Nyl Bik Fuel Line
44	17670412	Screw Hexwsh Thdrol 1/4-20x3/4
45	17000612	Screw Hexwsh Thdr 3/8-16 x 3/4
46	19091416	Washer 9/32 X 7/8 X 16ga
62	STD551131	Washer Lock Hvy Hlcl Spr 5/16
66	127951	Stop Throttle
72	71070512	Screw Hexhd Cap 5/16-18x3/4
78	17060620	Screw 3/8-16x1-1/4
81	73510400	Nut Keps Hex 1/4-20unc

**NOTE:** All component dimensions given in U.S. inches  
1 inch = 25.4 mm

# REPAIR PARTS

TRACTOR- -MODEL NO. 917.250420

## MOWER LIFT

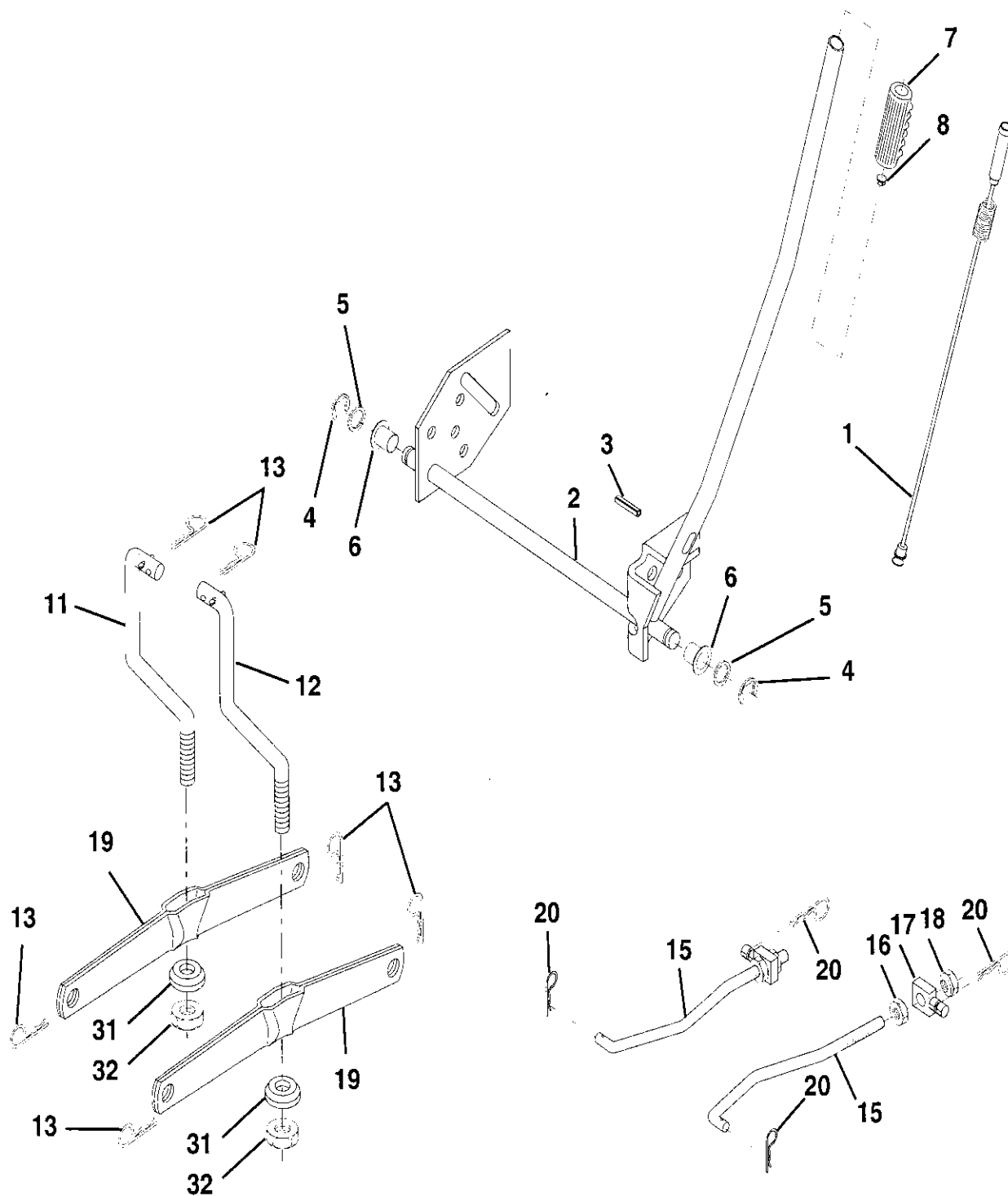



# REPAIR PARTS

TRACTOR- -MODEL NO. 917.250420

## MOWER LIFT

KEY NO.	PART NO.	DESCRIPTION
1	159460	Washer Asm Inner Spring W/ Plunger
2	159471	Shaft Asm. Lift RH
3	105767X	Pin Groove
4	12000002	E Ring #5133-62
5	19211621	Washer 21/32 x 1 x 21 Ga.
6	120183X	Bearing Nylon
7	125631X	Grip Handle Fluted
8	122365X	Button Plunger Read
11	139865	Link Asm Lift L.H.
12	139866	Link Asm Lift R.H.
13	STD624008	Retainer Spring
15	173288	Link Front
16	73350800	Nut Jam Hex 1/2-13 Unc
17	130171	Trunnion Blk Zinc
18	73800800	Nut Lockw/wsh 1/2-13 Unc
19	139868	Arm Suspension Mower
20	163552	Retainer Spring
31	169865	Bearing, Pvt. Lift.
32	73540600	Nut Crownlock 3/8-24

**NOTE:** All component dimensions given in U.S. inches  
1 inch = 25.4 mm



# REPAIR PARTS

TRACTOR- -MODEL NO. 917.250420

## MOWER

KEY NO.	PART NO.	DESCRIPTION	KEY NO.	PART NO.	DESCRIPTION
1	170280	Mower Housing Assembly	68	144200	Belt
2	72140506	Bolt, Carriage 5/16-18 x 3/4	69	76020312	Pin, Cotter 3/32 x 3/4
3	138017	Bracket Asm. Fram Sway Bar	86	7631J	Runner, LH
4	169970	Bracket, Asm. Deck Sway Bar	87	128772	Runner, RH
5	4939M	Retainer, Spring	88	19111216	Washer 11/32 x 3/4 x 16 Ga
6	130832	Asm. Suspension Rear	89	19131612	Washer 13/32 x 1 x 12 Ga
8	850857	Bolt, Hex 3/8-24 x 1-1/4 Gr 8	107	133502	Spacer, Retainer
9	10030600	Washer, Lock, Hlcl Sprg 3/8	108	133503	Stiffener, Idler Arm
10	140296	Washer, Hard Blade Mower Vented	109	74760640	Bolt, Hex Head 3/8-16 x2-1/2
11	134148	Blade, Mower, Mulching 38"	110	142587	Upstop Deck Front 38"
13	137645	Shaft and Bearing Assembly (Includes Key Number 15)	113	17060512	Screw 5/16-18 x 3/4
14	128774	Mandrel Housing, Vented	122	131289	Rod, Brake, LH
15	110485X	Ball Bearing, Mandrel	123	169971	Rod, Brake, RH
16	174493	Stripper, Mower, Vented	146	165891	Bolt Carriage Idler
19	132827	Bolt, Shoulder	148	169022	Spring Return Idler
21	73680500	Nut, Crownlock 5/16-18	149	165898	Retainer Spring Yellow Zinc
23	137607	Bracket, Mower Deflector	150	19091216	Washer 9/32 x 3/4 x 16 Ga.
24	105304X	Cap, Sleeve	151	169670	Bracket Clutch
25	123713X	Spring, Deflector	152	172758	Cable Clutch 38 In
26	110452X	Nut, Push	153	169674	Washer Flat 3/8" Type B
27	106736X428	Shield, Deflector	154	169675	Spring Retainer
28	19111016	Washer 11/32 x 3/4 x 16 Ga	155	169671	Spring Retention Lever
29	106735X	Rod, Hinge	156	169672	Spacer
30	157722	Screw, Thdro Washer Hd	157	169669	Rod Clutch
31	129963	Washer, Spacer	158	17720410	Screw Hex Thd Cut 1/4-20x5/8
32	153532	Pulley, Mandrel	--	130794	Mandrel Assembly (Includes Key Numbers 13-15, 17-19, 31 and 33)
33	137266	Nut, Flangelock 9/16	--	171665	Mower Deck, Complete
36	131494	Pulley, Idler, Flat			
40	73680600	Nut Crownlock 3/8-16 UNC			
45	4497H	Retainer, Spring			
53	130840	Brake Assembly			
54	133943	Washer Hardened			
55	133840	Idler Arm Assembly			
56	165723	Spacer, Retainer			
67	149846	Knob			

**NOTE:** All component dimensions given in U.S. inches  
1 inch = 25.4 mm

# REPAIR PARTS

TRACTOR - - MODEL NUMBER 917.250420

DANA TRANSAXLE - MODEL NUMBER 4360-139

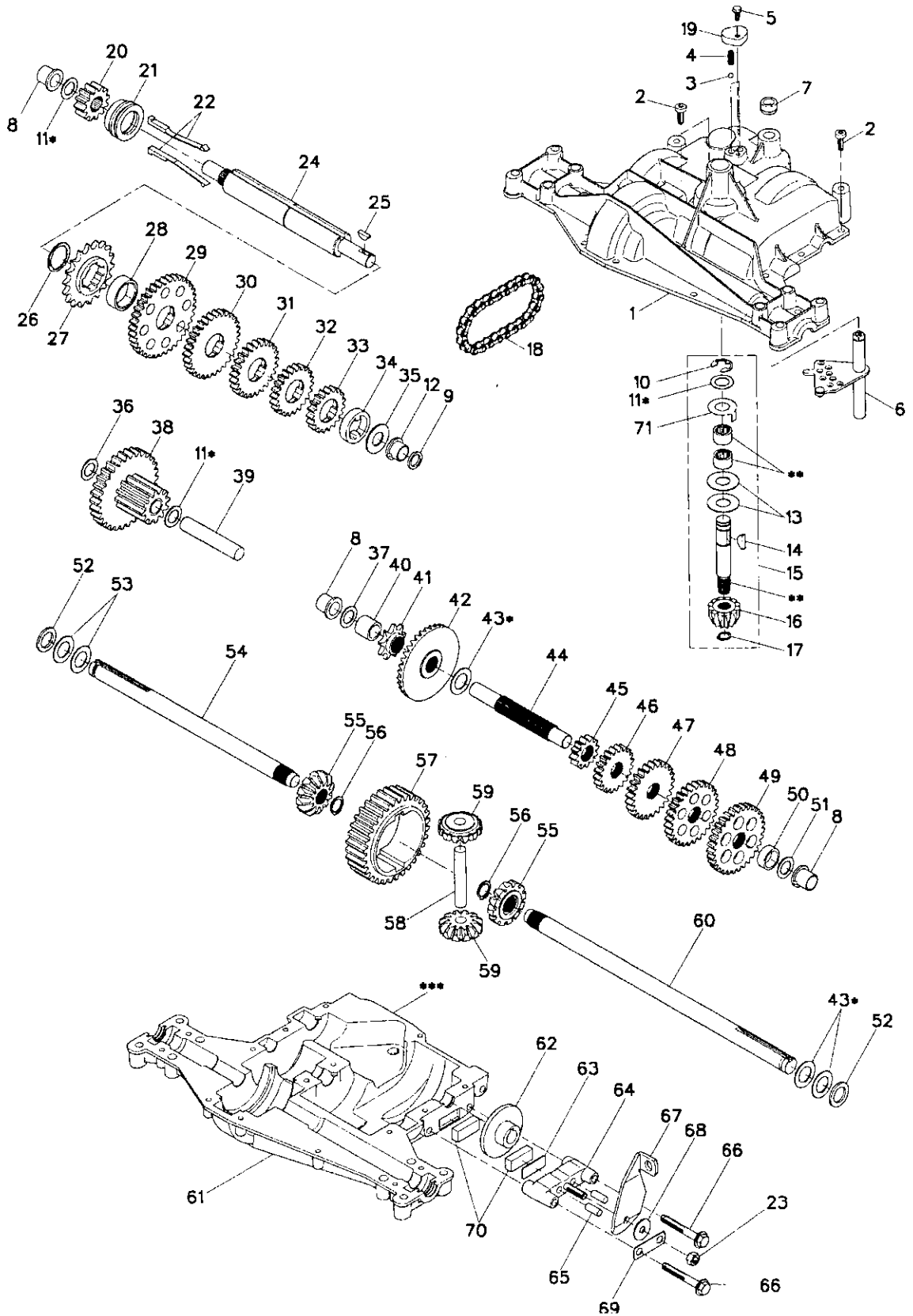

# REPAIR PARTS

## TRACTOR - - MODEL NUMBER 917.250420

### DANA TRANSAXLE - MODEL NUMBER 4360-139

KEY NO.	PART NO.	DESCRIPTION	KEY NO.	PART NO.	DESCRIPTION
1	170981	Housing, Upper	41	105928X	Sprocket, 9T
2	2274J	Screw, Tapping, 1/4-20 X .734	42	170988	Gear, Bevel, 36T
3	134400	Ball, Detent	43	134394	*Assy, Kit, Shim, .750 Shaft
4	105904X	Spring, Detent	44	120473X	Shaft, Drive
5	160940	Screw, Tapping, No. 10-24 X .482	45	142678	Gear, Spur, 12T
6	138235	Assy, Kit, Shifter	46	124641 X	Gear, Spur, 20T
7	108727X	V-Ring	47	106589X	Gear, Spur, 25T
8	148266	Bearing, Flange	48	120408X	Gear, Spur, 28T
9	148269	Seal, Oil	49	105937X	Gear, Spur, 31T
10	2225J	Ring, Retaining	50	105936X	Spacer, .781 X 1.00 X .375
11	134793	*Assy, Kit, Shim, .625 Shaft	51	2226J	Washer, Plain, .632 X 1.00 X .060
12	148268	Bearing, Flange	52	134401	Washer, Neoprene
13	120415X	Washer, Plain, .632 X 1.38 X .046	53	2264J	Washer, Plain, .758 X 1.25 X .031
14	142674	Key, Woodruff, No. 9	54	160946	Axle, LH
15	170983	Assy, Kit, Input Shaft	55	170990	Gear, Miter, T, Splined
16	170986	Pinion, Bevel, 12T	56	160948	Ring, Retaining
17	105909X	Ring, Retaining	57	110071X	Gear, Spur, 32T
18	105910X	Chain, 24 Pitches	58	120952X	Shaft, Cross
19	160942	Cover, Detent	59	170991	Gear, Miter, 1 2T, Idler
20	160943	Gear, Spur, 1 2T	60	160950	Axle, RH
21	148267	Collar, Clutch	61	170992	Housing, Lower
22	138236	Assy, Kit, Clutch Keys	62	7294J	Disc, Brake
23	73810500	Nut, Lock, 5/16-24	63	108989X	Spacer, Brake Puck
24	142676	Shaft, Intermediate	64	160952	Jaw, Brake
25	2244J	Key, Woodruff, No. 61	65	120954X	Pin, Dowel
26	105916X	Ring, Retaining	66	160953	Screw, Tapping, 5/16-18 X 2.35
27	12047OX	Sprocket, 1 8T	67	138244	Lever, Actuating
28	110070X	Spacer, 1. 131 X 1.45 X .494	68	108996X	Washer, Plain, .321 X 1.00 X .055
29	142677	Gear, Spur, 37T	69	160954	Bracket, Anti-Rotation
30	124644X	Gear, Spur, 30T	70	120951X	Puck, Friction
31	108980X	Gear, Spur, 25T	71	174256	Washer, Anti Rotation
32	120406X	Gear, Spur, 22T	72	120416X	Grease
33	134796	Gear, Spur, 1 9T			
34	134797	Spacer, 1. 133 X 1.50 X .375			
35	105925X	Washer, Plain, .640 X 1.37 X .061			
36	2228J	Washer, Plain, .632 X 1.00 X .046			
37	170987	Washer, Plain, .632 X 1.00 X .031			
38	174255	Assy, Gear, Comb., 12T & 30T			
39	124639X	Shaft, Idler			
40	120472X	Spacer, .633 X .87 X .755			

**NOTE:** All component dimensions given in U.S. inches  
1 inch = 25.4 mm

- \* Use in various combinations to maintain proper clearances.
- \*\* Order Key No. 15.
- \*\*\* Silicone Sealant to be applied between Upper and Lower Housings (use Loctite Ultra Gray Silicone 5699 or equivalent).

# REPAIR PARTS

TRACTOR - - MODEL NUMBER 917.250420

BRIGGS & STRATTON ENGINE - - MODEL NUMBER 28R707, TYPE NUMBER 1147-E1

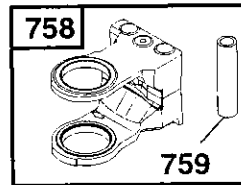
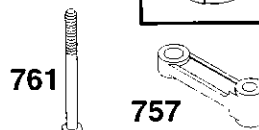
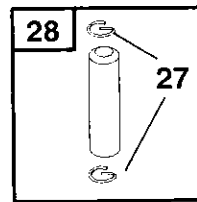
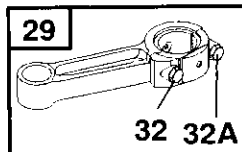
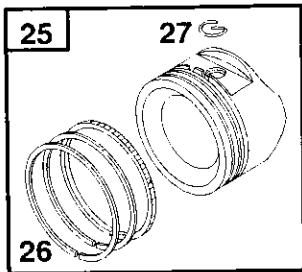
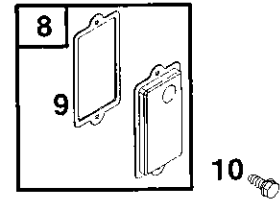
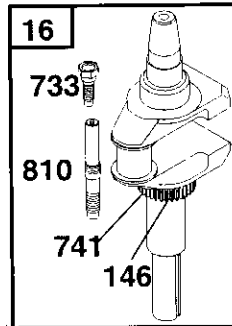
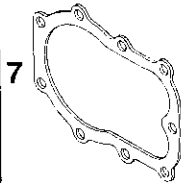
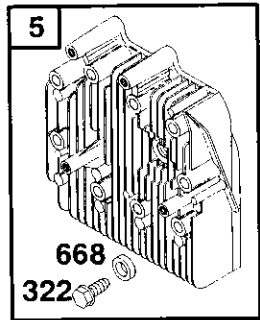
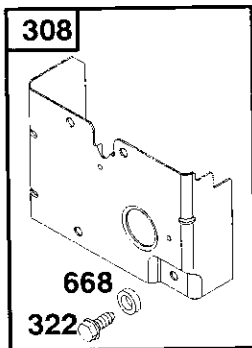
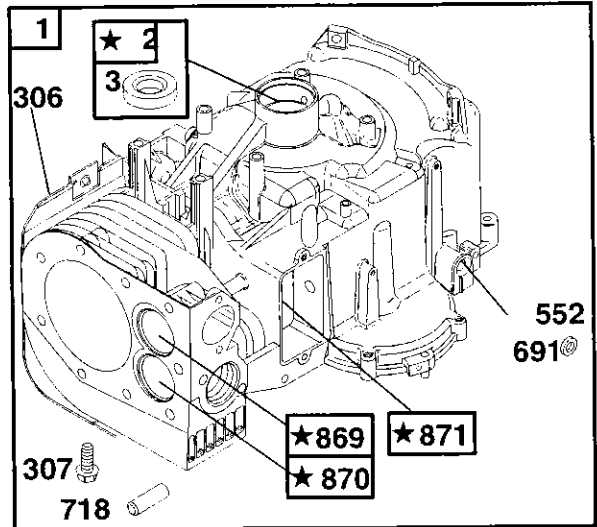
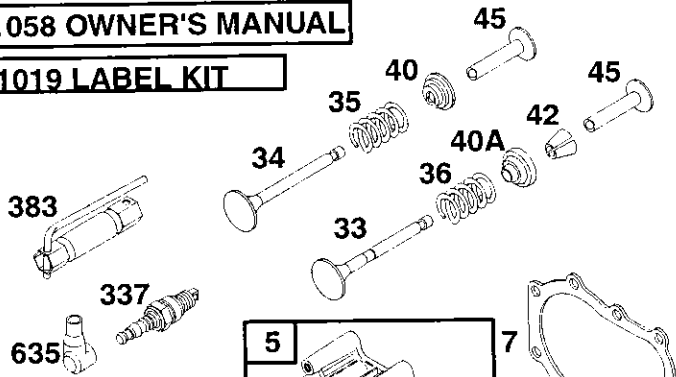

★ REQUIRES SPECIAL TOOLS TO INSTALL. SEE REPAIR INSTRUCTION MANUAL.

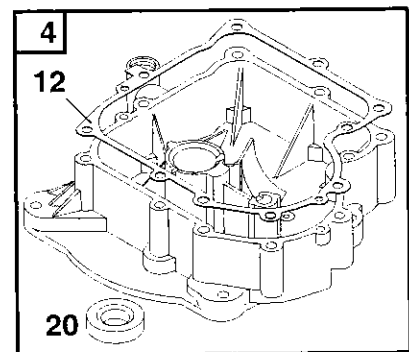
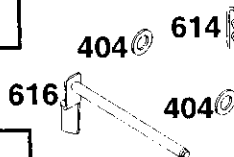
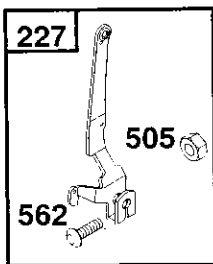
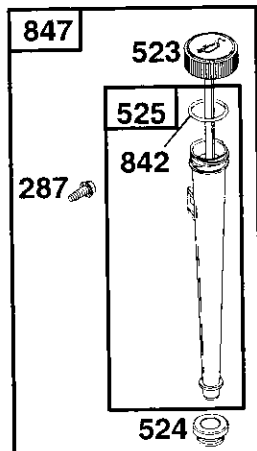
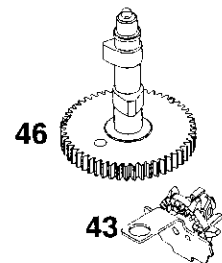

# REPAIR PARTS

TRACTOR - - MODEL NUMBER 917.250420

BRIGGS & STRATTON ENGINE - - MODEL NUMBER 28R707, TYPE NUMBER 1147-E1

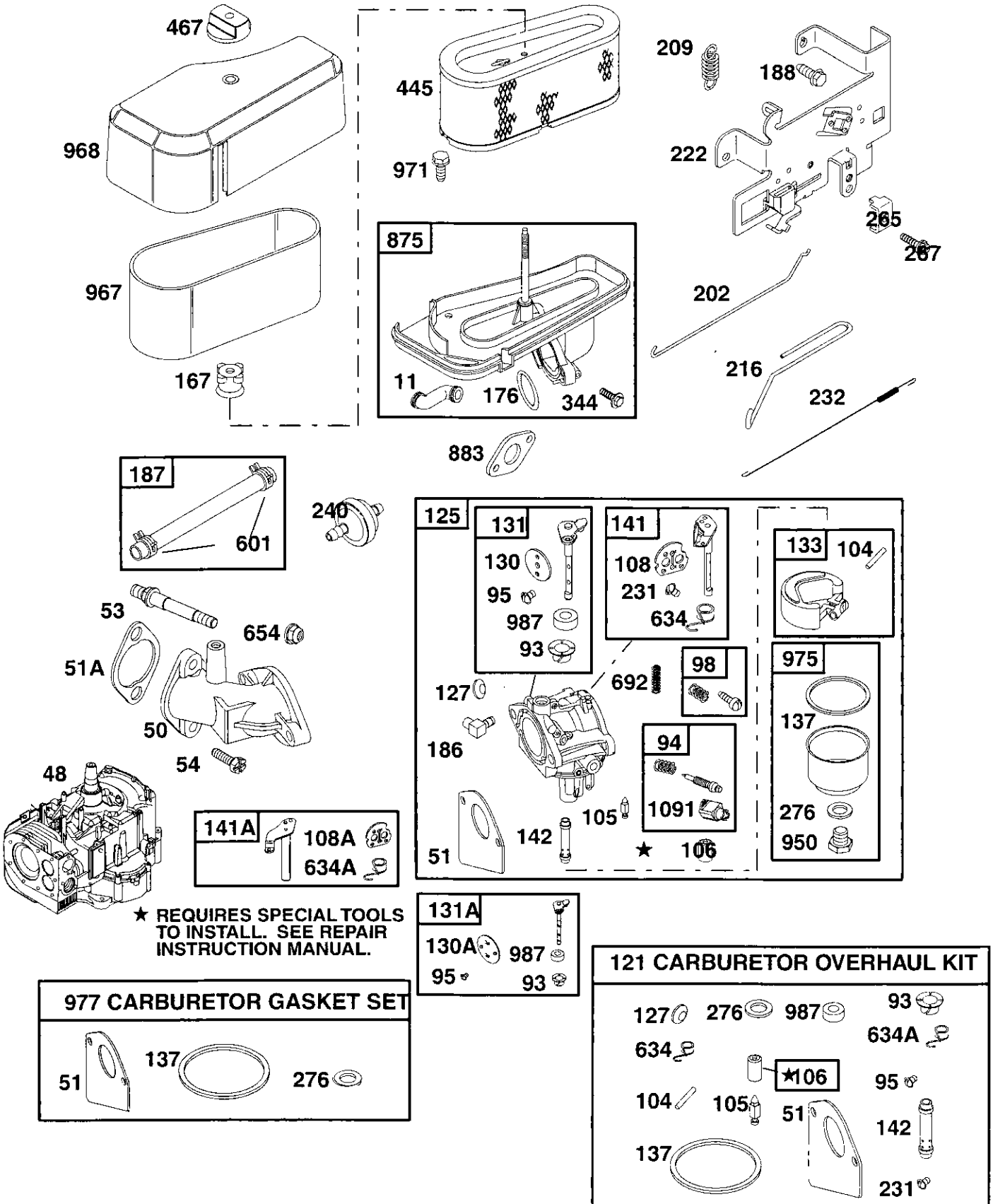

# REPAIR PARTS

TRACTOR - - MODEL NUMBER 917.250420

BRIGGS & STRATTON ENGINE - - MODEL NUMBER 28R707, TYPE NUMBER 1147-E1

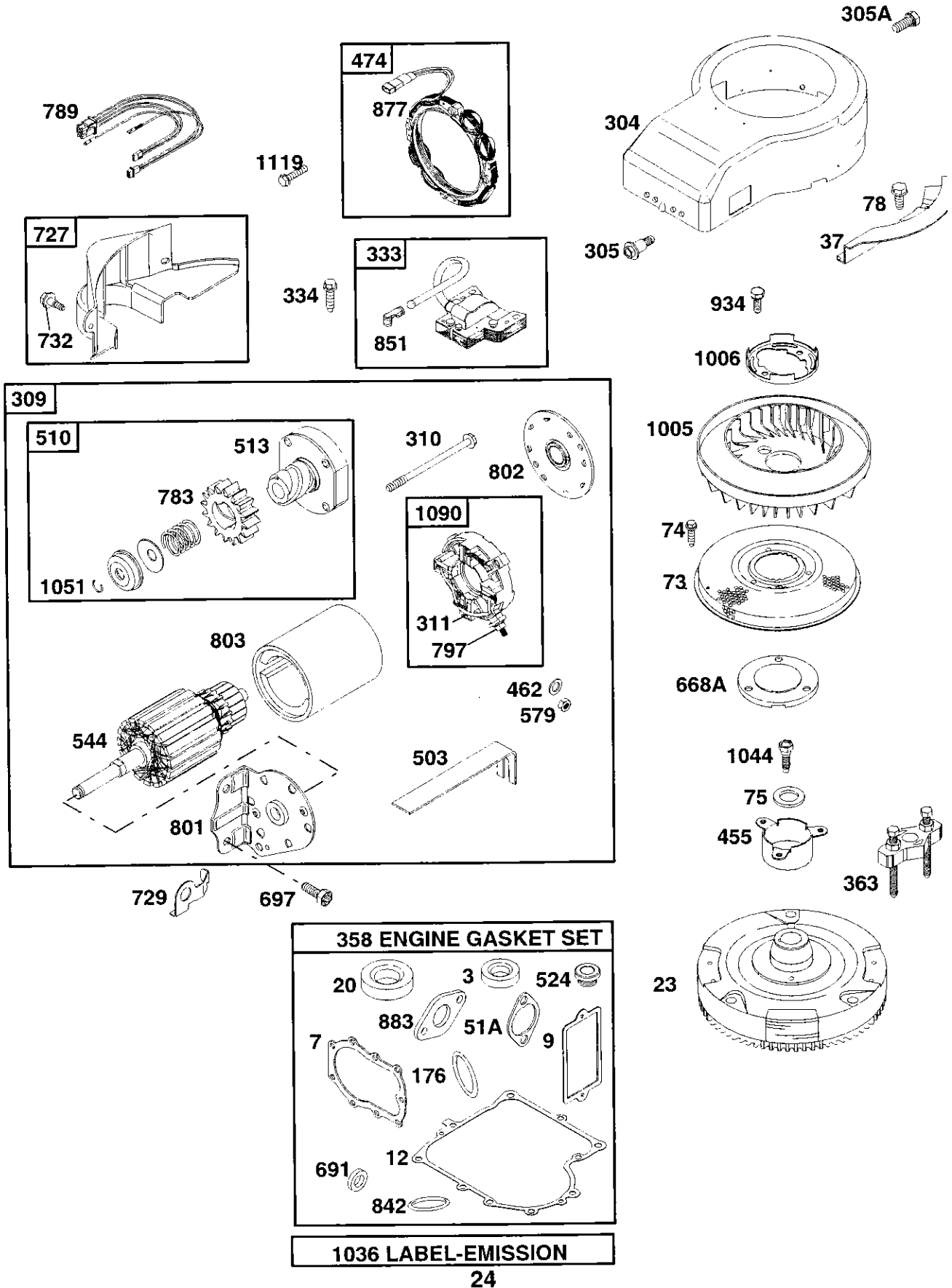



# REPAIR PARTS

TRACTOR - - MODEL NUMBER 917.250420

BRIGGS & STRATTON ENGINE - - MODEL NUMBER 28R707, TYPE NUMBER 1147-E1

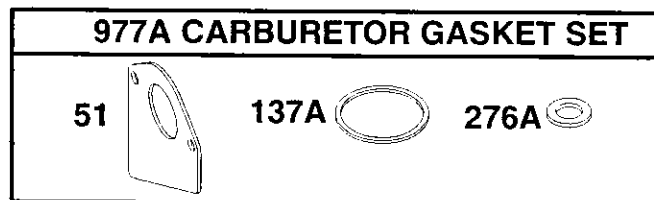
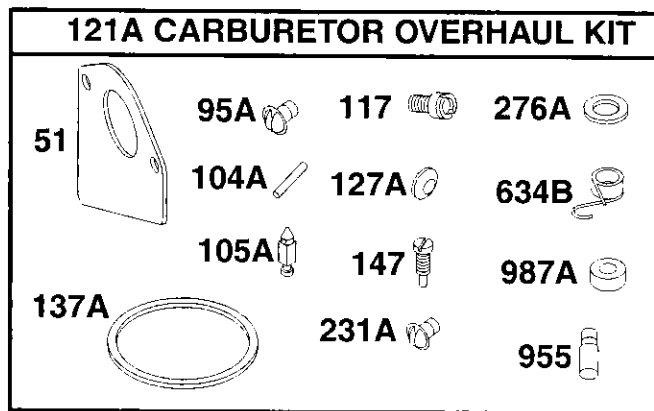
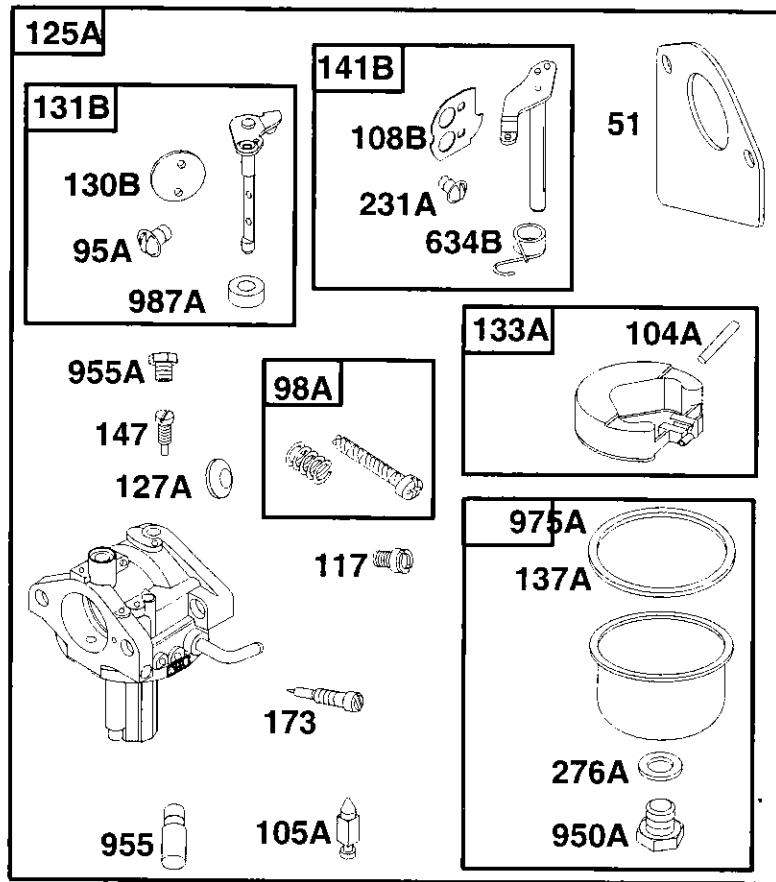

# REPAIR PARTS

## TRACTOR - - MODEL NUMBER 917.250420

### BRIGGS & STRATTON ENGINE - - MODEL NUMBER 28R707, TYPE NUMBER 1147-E1

KEY NO.	PART NO.	DESCRIPTION	KEY NO.	PART NO.	DESCRIPTION
1	496413	Cylinder Assembly	95A	690718	Ø Screw (Throttle Valve)
2	399269	Kit-Bushing/Seal	98	495800	Idle Speed Kit
3	391086	• Seal-Oil (Magneto Side)	98A	694907	Idle Speed Kit
4	494238	Sump-Engine	104	690525	Ø Pin-Float Hinge
5	494240	Head-Cylinder	104A	694918	Ø Pin-Float Hinge
7	271866	•+ Gasket-Cylinder Head	105	231855	Ø Valve-Float Needle
8	495735	Breather Assembly	105A	694922	Ø Valve-Float Needle
9	27803	•+ Gasket-Breather	106	690577	Ø Seat-Inlet
10	691666	Screw (Breather Assembly)	108	690464	Valve-Choke (Manual Choke)
11	692253	Tube-Breather	108A	692344	Valve-Choke (Choke A Matic)
12	692226	• Gasket-Crankcase (.015 Thick, Std.)	108B	694923	Valve-Choke
	692406	• Gasket-Crankcase (.005 Thick)	117	690880	Ø Jet-Main (Standard)
	692405	• Gasket-Crankcase (.009 Thick)		694925	Ø Jet-Main (High Altitude)
13	690904	Screw (Cylinder Head)	121	499220	Kit-Carburetor Overhaul (Walbro)
15	690946	Plug-Oil Drain	121A	694930	Kit-Carburetor Overhaul (Nikki)
16	693944	Crankshaft	125	498027	Carburetor (Walbro)
20	291675	• Seal-Oil (PTO Side)	125A	694941	Carburetor (Nikki)
22	692125	Screw (Engine Sump)	127	695005	Ø Plug-Welch
23	693557	Flywheel (Steel Ring Gear)	127A	694916	Ø Plug-Welch
24	222698	Key-Flywheel	130	691750	Valve-Throttle
25	499284	Piston Assembly (Standard)	130A	694917	Valve-Throttle
	499288	Piston Assembly (.010 O.S.)	130B	694917	Valve-Throttle
	499292	Piston Assembly (.020 O.S.)	131	494885	Throttle Shaft Kit
	499296	Piston Assembly (.030 O.S.)	131A	494379	Throttle Shaft Kit
26	391780	Ring Set-Piston (Standard)	131B	694909	Throttle Shaft Kit
	392331	Ring Set-Piston (Chrome, Standard)	133	494381	Float-Carburetor
	391781	Ring Set-Piston (.010 O.S.)	133A	694914	Float-Carburetor
	391782	Ring Set-Piston (.020 O.S.)	137	281165	Ø‡ Gasket-Float Bowl
	499999	Ring Set-Piston (.030 O.S.)	137A	694920	Ø‡ Gasket-Float Bowl
27	691299	Lock-Piston Pin	141	495097	Choke Shaft Kit (Manual Choke)
28	498319	Pin-Piston (Standard)	141A	495931	Choke Shaft Kit (Choke A Matic)
	498320	Pin-Piston (.005 O.S.)	141B	694913	Choke Shaft Kit
29	494504	Rod-Connecting (Standard)	142	691434	Ø Nozzle-Carburetor (Standard)
	490469	Rod-Connecting (.020 U.S.)		497737	Nozzle-Carburetor (High Altitude)
32	690356	Screw (Connecting Rod)	146	691639	Key-Timing
32A	690348	Screw (Connecting Rod)	147	694927	Ø Jet-Pilot
33	262246	Valve-Exhaust	167	692297	Seal-Air Cleaner Nut
34	262247	Valve-Intake	173	694926	Valve-Idle Mixture
35	691605	Spring-Valve (Intake)	176	691917	•+ O-Ring Seal (Air Cleaner Base)
36	691597	Spring-Valve (Exhaust)	186	692317	Connector-Hose
37	690456	Guard-Flywheel	187	691050	Line-Fuel (Cut to Required Length)
40	690656	Retainer-Valve (Intake)	188	691693	Screw (Control Bracket)
40A	691939	Retainer-Valve (Exhaust)	202	691841	Link-Mechanical Governor
42	494553	Keeper-Valve	209	690480	Spring-Governor
43	691968	Slinger-Governor/Oil	216	691840	Link-Choke
45	691811	Tappet-Valve	222	694042	Bracket-Control
46	692123	Camshaft	227	691374	Control Lever-Governor
48	496050	Short Block (Replacement Engine 311707-0028-E1)	231	691636	Ø Screw (Choke Valve)
50	691711	Manifold-Intake			
51	692284	Ø‡ Gasket-Intake			
51A	272554	•+ Gasket-Intake			
53	691098	Stud (Carburetor)			
54	690953	Screw (Intake Manifold)			
73	690492	Screen-Rotating			
74	691655	Screw (Rotating Screen)			
75	690582	Washer (Flywheel)			
78	690661	Screw (Flywheel Guard)			
93	690602	Ø Bushing-Throttle Shaft			
94	498030	Idle Mixture Kit			
95	691636	Ø Screw (Throttle Valve)			

RPM Settings: Low Speed: 1900-2100  
High Speed: 3000-3200

- Included in Engine Gasket Set, Key. No. 358
- Ø Included in Carburetor Overhaul Kit, Key. No. 121 and 121A
- ‡ Included in Carburetor Gasket Set, Key. No. 977 and 977A
- + Included in Valve Gasket Set, Key. No. 1095

**NOTE:** All component dimensions given in U.S. inches 1 inch = 25.4 mm

# REPAIR PARTS

## TRACTOR - - MODEL NUMBER 917.250420

### BRIGGS & STRATTON ENGINE - - MODEL NUMBER 28R707, TYPE NUMBER 1147-E1

KEY NO.	PART NO.	DESCRIPTION	KEY NO.	PART NO.	DESCRIPTION
231A	690718	Ø Screw (Choke Valve)	741	691284	Gear-Timing
232	691842	Spring-Governor Link	757	691714	Link-Counterweight
240	394358	Filter-Fuel	758	692423	Counterweight
265	691024	Clamp-Casing	759	691239	Pin-Counterweight
267	695134	Screw (Casing Clamp)	761	691096	Screw (Counterweight)
276	692255	Ø‡ Sealing Washer	783	693713	Gear-Pinion
276A	690997	Ø‡ Sealing Washer	789	695050	Harness-Wiring
287	691002	Screw (Dipstick Tube)	797	693167	Nut (Brush Retainer)
304	690844	Housing-Blower	801	691429	Cap-Drive
305	692198	Screw (Blower Housing)	802	691286	Cap-End
305A	692127	Screw (Blower Housing)	803	693757	Housing-Starter
306	690459	Shield-Cylinder	810	691779	Extension-Crankshaft
307	691003	Screw (Cylinder Shield)	842	691870	• Dipstick/Tube Seal
308	491490	Cover-Cylinder Head	847	496415	Dipstick/Tube Assembly
309	693551	Motor-Starter	851	493880	Terminal-Spark Plug
310	690323	Bolt (Starter Motor)	869	691802	Seat-Valve (Intake)
311	497608	Brush Set	870	262405	Seat-Valve (Exhaust)
322	692198	Screw (Cylinder Head Cover)	871	261961	Bushing-Valve Guide (Exhaust Valve)
333	492341	Armature-Magneto		231218	Bushing-Valve Guide (Brass Intake Valve)
334	691061	Screw (Armature Magneto)	875	694942	Base-Air Cleaner
337	802592	Spark Plug	877	393456	Wire-Alternator
344	693675	Screw (Cable Clamp)	883	692236	*+ Gasket-Exhaust
358	494241	Engine Gasket Set	934	691058	Screw (Fan Retainer)
363	19203	Flywheel Puller	950	691657	Screw-Float Bowl
383	89838	Wrench-Spark Plug	950A	694919	Screw-Float Bowl
404	691691	Washer (Governor Crank)	955	694924	Ø Plug-Carburetor
445	496894	Filter-Air Cleaner Cartridge	955A	694921	Plug-Carburetor
455	691173	Cup-Flywheel	967	272403	Filter-Pre Cleaner
462	691261	Washer (Starter Cable)	968	691916	Cover-Air Cleaner
467	691668	Knob-Air Cleaner	971	692126	Screw (Air Cleaner Base)
474	691063	Alternator	975	495933	Bowl-Float
503	691532	Strap-Starter	975A	694908	Bowl-Float
505	691251	Nut (Governor Control Lever)	977	494385	Gasket Set-Carburetor
510	693699	Drive-Starter	977A	694931	Gasket Set-Carburetor
513	692024	Clutch-Drive	987	691326	Ø Seal-Throttle Shaft
523	692014	Dipstick	987A	690998	Ø Seal-Throttle Shaft
524	281370	• Seal-Dipstick Tube	1005	695056	Fan-Flywheel
525	691398	Tube-Dipstick	1006	690452	Retainer-Fan
544	692034	Armature-Starter	1019	491252	Kit-Label
552	491986	Bushing-Governor Lever	1036	695699	Label-Emissions
562	691119	Bolt (Governor Control Lever)	1044	691658	Screw (Flywheel)
579	691029	Nut (Starter Cable)	1051	691265	Ring-Retainer
601	95162	Clamp-Hose	1058	274787	Owner's Manual
614	691620	Pin-Cotter	1090	691293	Retainer-Brush
616	692012	Crank-Governor	1091	691333	Cap-Limiter
634	690801	Ø Seal/Spring Assembly (Manual Choke)	1095	498539	Valve Gasket Set
634A	690802	Ø Seal/Spring Assembly (Choke A Matic)	1119	691183	Screw (Alternator)
634B	694912	Ø Seal/Spring Assembly			
635	66538	Boot-Spark Plug			
654	690958	Nut (Carburetor)			
668	690510	Spacer			
668A	691323	Spacer			
691	692407	• Governor Shaft Seal			
692	690572	Spring-Detent			
697	690372	Screw (Starter Motor)			
718	690959	Pin-Locating			
727	490324	Cover-Starter Drive			
729	691224	Clip-Wire			
732	691002	Screw (Starter Drive Cover)			
733	691658	Screw (Crankshaft Extension)			

RPM Settings: Low Speed: 1900-2100  
High Speed: 3000-3200

- Included in Engine Gasket Set, Key. No. 358
- Ø Included in Carburetor Overhaul Kit, Key. No. 121 and 121A
- ‡ Included in Carburetor Gasket Set, Key. No. 977 and 977A
- + Included in Valve Gasket Set, Key. No. 1095

**NOTE:** All component dimensions given in U.S. inches  
1 inch = 25.4 mm

## **LIMITED ONE YEAR WARRANTY ON CRAFTSMAN RIDING EQUIPMENT**

For one (1) year from the date of purchase, if this Craftsman Riding Equipment is maintained, lubricated and tuned up according to the instructions in the owner's manual, Sears will repair or replace, free of charge, any parts found to be defective in material or workmanship.

This Warranty does not cover:

- Expendable items which become worn during normal use, such as blades, spark plugs, air cleaners, belts, etc.
- Tire replacement or repair caused by punctures from outside objects, such as nails, thorns, stumps, or glass.
- Repairs necessary because of operator abuse, negligence, improper storage or accident or the failure to maintain the equipment according to the instructions contained in the owner's manual.
- Riding equipment used for commercial or rental purposes.

## **LIMITED 90 DAY WARRANTY ON BATTERY**

For ninety (90) days from date of purchase, if any battery included with this riding equipment proves defective in material or workmanship and our testing determines the battery will not hold a charge, Sears will replace the battery at no charge.

IN-HOME WARRANTY SERVICE ON YOUR CRAFTSMAN RIDING EQUIPMENT IS AVAILABLE AT NO-CHARGE FOR 30 DAYS FROM THE DATE OF PURCHASE. PLEASE CONTACT YOUR NEAREST SERVICE CENTER. AFTER 30 DAYS FROM THE DATE OF PURCHASE, WARRANTY SERVICE IS AVAILABLE BY TAKING YOUR CRAFTSMAN RIDING EQUIPMENT TO YOUR NEAREST SEARS SERVICE CENTER. (IN-HOME WARRANTY SERVICE WILL STILL BE AVAILABLE AFTER 30 DAYS FROM THE DATE OF PURCHASE BUT A STANDARD TRIP CHARGE WILL APPLY.) THIS WARRANTY APPLIES ONLY WHILE THIS PRODUCT IS IN THE UNITED STATES.

This Warranty gives you specific legal rights, and you may also have other rights which may vary from state to state.

SEARS, ROEBUCK AND CO., D/817 WA, HOFFMAN ESTATES, IL 60179

---

# SERVICE NOTES

---

---

# SERVICE NOTES

---

---

# SERVICE NOTES

---

**CRAFTSMAN®**