

REPAIR PARTS MANUAL
MODEL NO. 253653
Lawn Tractor

CRAFTSMAN[®]

HOW TO USE THIS MANUAL

This manual is designed to provide the customer with a means to identify the parts on his/her tractor when ordering repair parts. The illustrations may or may not represent the actual assemblies; therefore, it is not recommended to use this manual as a guide to assemble or disassemble the tractor. Some hardware and parts are drawn larger in order to more readily identify them.

Each tractor has its own model number.

The model number for your tractor can be found on the fender under the seat.

When ordering parts, always give the following information:

- Product - "Tractor"
- Model Number - "253653"
- Part Number
- Part Description

TABLE OF CONTENTS

SCHEMATIC	3
ELECTRICAL.....	4-5
CHASSIS	6-7
DRIVE.....	8-9
STEERING	10-11
SEAT	12
DECALS.....	13
ENGINE.....	14-15
MOWER LIFT.....	16-17
MOWER DECK	18-19
TRANSAXLE BREAKDOWN	20-21
ENGINE BREAKDOWN.....	22-27
WARRANTY.....	BACK COVER

TRACTOR- -MODEL NO. 917.253653

SCHEMATIC

SCH11

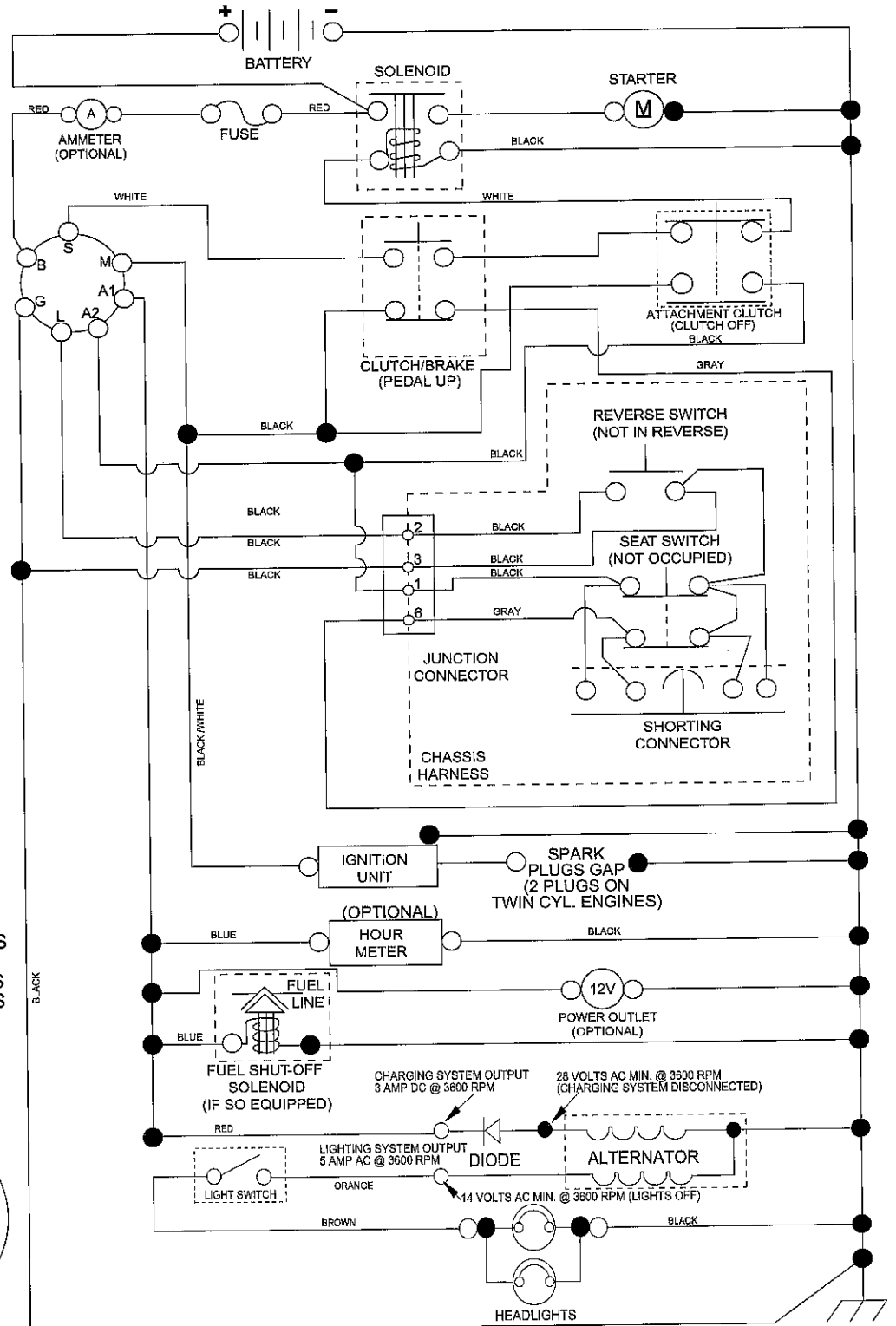

NOTE
YOUR TRACTOR IS EQUIPPED WITH A SPECIAL ALTERNATOR SYSTEM. THE LIGHTS ARE NOT CONNECTED TO THE BATTERY, BUT HAVE THEIR OWN ELECTRICAL SOURCE. BECAUSE OF THIS, THE BRIGHTNESS OF THE LIGHTS WILL CHANGE WITH ENGINE SPEED. AT IDLE THE LIGHTS WILL DIM. AS THE ENGINE IS SPEEDED UP, THE LIGHTS WILL BECOME THEIR BRIGHTEST.

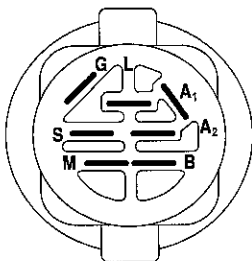

IGNITION SWITCH

POSITION	CIRCUIT	"MAKE"
OFF	M+G+A1	
RUN/OVERRIDE	B+A1	
RUN	B+A1	L+A2
START	B + S + A1	

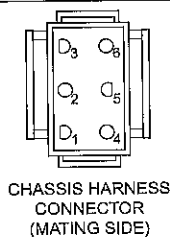

CHASSIS HARNESS CONNECTOR (MATING SIDE)

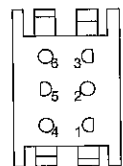

DASH HARNESS CONNECTOR (MATING SIDE)

WIRING INSULATED CLIPS
NOTE: IF WIRING INSULATED CLIPS WERE REMOVED FOR SERVICING OF UNIT, THEY SHOULD BE RE-INSTALLED TO PROPERLY SECURE YOUR WIRING.

NON-REMOVABLE CONNECTIONS
REMOVABLE CONNECTIONS

REPAIR PARTS

TRACTOR- -MODEL NO. 917.253653

ELECTRICAL

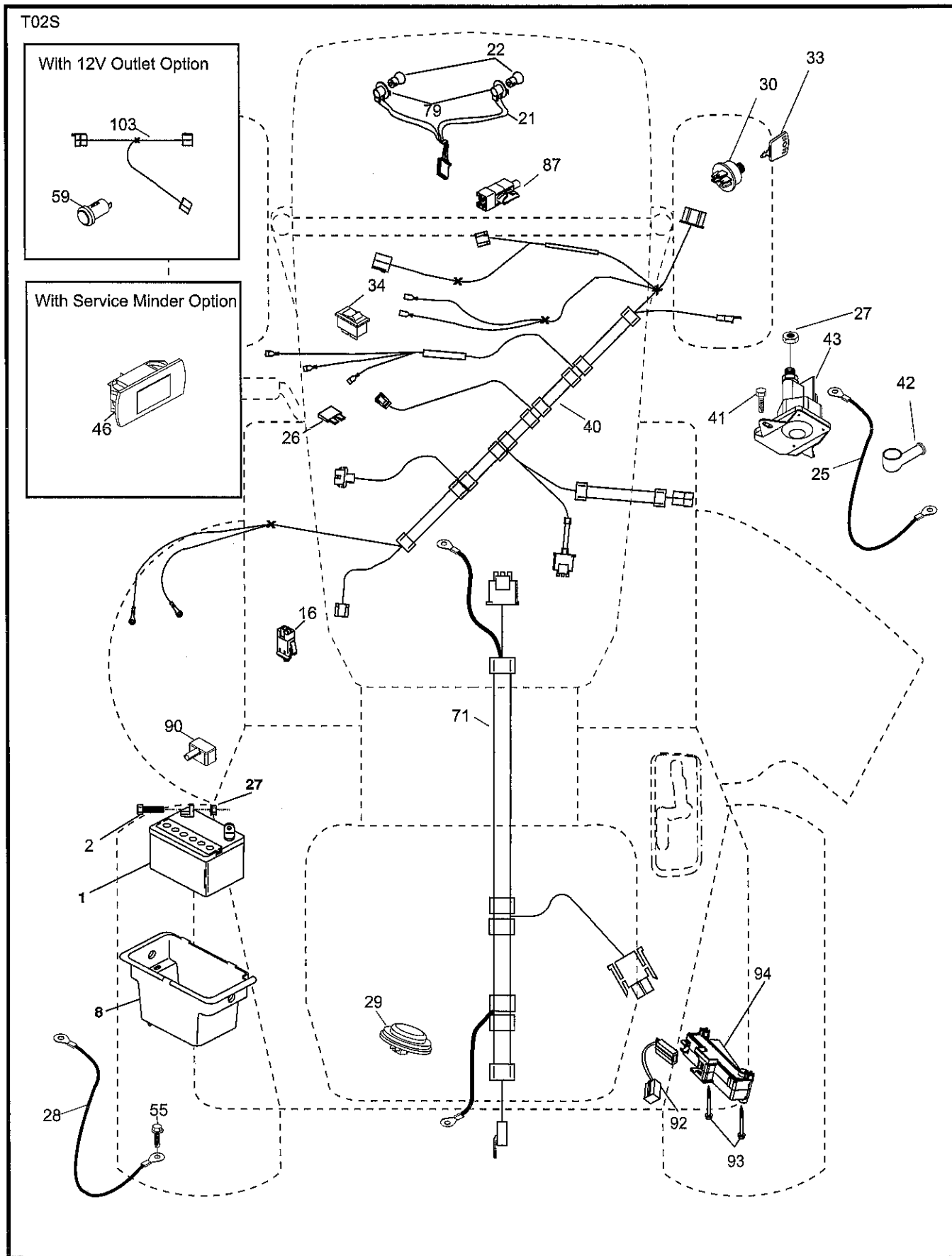

REPAIR PARTS

TRACTOR- -MODEL NO. 917.253653

ELECTRICAL

KEY NO.	PART NO.	DESCRIPTION
1	163465	Battery
2	74760412	Bolt Hex Hd 1/4-20 unc x 3/4
8	193228	Box Battery
16	176138	Switch Interlock Push-In
21	400252	Harness Socket Light w/4152J
22	4152J	Bulb Light
25	412894	Cable Starter
26	175158	Fuse
27	73510400	Nut Keps Hex 1/4-20 unc
28	198885	Cable, Ground
29	401545	Switch, Seat
30	193350	Switch, Ign
33	411934	Key/Chain
34	110712X	Switch Light / Reset
40	401098	Harness Ign. Dash
41	17720408	Screw Thd Cut 1/4-20 x 1/2
42	131563	Cover, Terminal
43	192507	Solenoid
55	17060512	Screw Thdrol 5/16-18 x 3/4 TYTT
71	400449	Harness Ign. Chassis
79	175242	Bulbholder Asm. Incan Descent
87	197802	Switch Interlock Clutch Cable
90	400725	Cover Terminal Battery
92	196615	Harness Pigtail Reverse Switch
93	192540	Screw Plastite 10 - 14 x 2 00
94	191834	Module Reverse Ros

NOTE: All component dimensions given in U.S. inches.
1 inch = 25.4 mm.

REPAIR PARTS

TRACTOR- -MODEL NO. 917.253653

CHASSIS AND ENCLOSURES

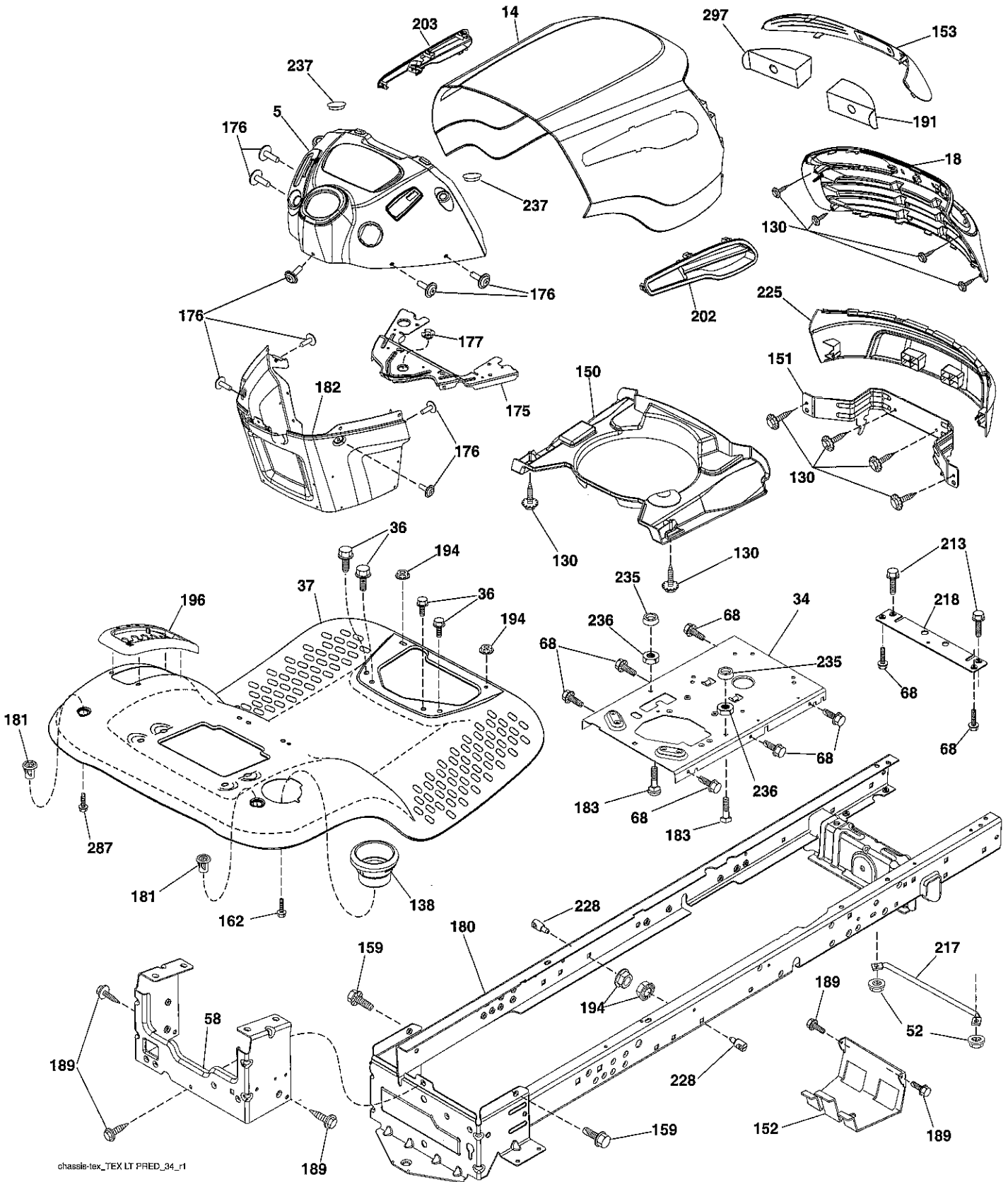

chassis-tex_TEX LT PRED_34_r1

REPAIR PARTS

TRACTOR- -MODEL NO. 917.253653

CHASSIS AND ENCLOSURES

KEY NO.	PART NO.	DESCRIPTION
5	408874X428	Dash
14	198416X613	Hood
18	423156	Grille
34	196125	Plate Engine
36	17060512	Screw 5/16-18 x 3/4
37	414872X613	Fender
52	73680500	Nut Crown Lock 5/16-18
58	412280	Drawbar Upper
68	17490508	Screw Thdrol 5/16-18 x 1/2
130	416358	Screw #10 x 0.750
138	193224X428	Cupholder
150	400267	Duct Heat Hood
151	187568	Bracket Pivot
152	199535	Shield Browning/Debris
153	400550X599	Lens
159	17000612	Screw Hexwsh Thdrol 3/8-16 x 3/4
162	142432	Screw Hex Wsh Hi-Lo 1/4 x 1/2
175	199472	Crossmember
176	400776	Screw 10-24 x 5/8 Wshd Qdrx
177	195228	Bushing Steering
180	415063	Chassis
181	193102X428	Bushing Mtg. Fender Crgo.
182	407176	Dash Lower
183	74520520	Bolt Full Thd 5/16-18 x 1-1/4
189	17000512	Screw 5/16-18 x 3/4
191	416502	Insert Reflective RH
194	73900500	Nut Lock Hex Flange 5/16-18
196	414579	Console Asm. Deck Lift
202	423173	Vent Hood Side Panel RH
203	423172	Vent Hood Side Panel LH
213	74760512	Bolt Hex Hd 5/16-18 unc x 3/4
217	409167	Rod Pivot Hood
218	196395	X-Piece Hood Stop
225	400549X613	Bumper
228	195161	Stud Fastener
235	406129	Spacer Fender
236	73930500	Nut Center Lock 5/16-18
237	403704	Plug Mount Cargo
287	17600406	Screw 1/4-20 x 3/8
297	401827	Insert Reflective LH

NOTE: All component dimensions given in U.S. inches.
1 inch = 25.4 mm.

REPAIR PARTS

TRACTOR- -MODEL NO. 917.253653

DRIVE

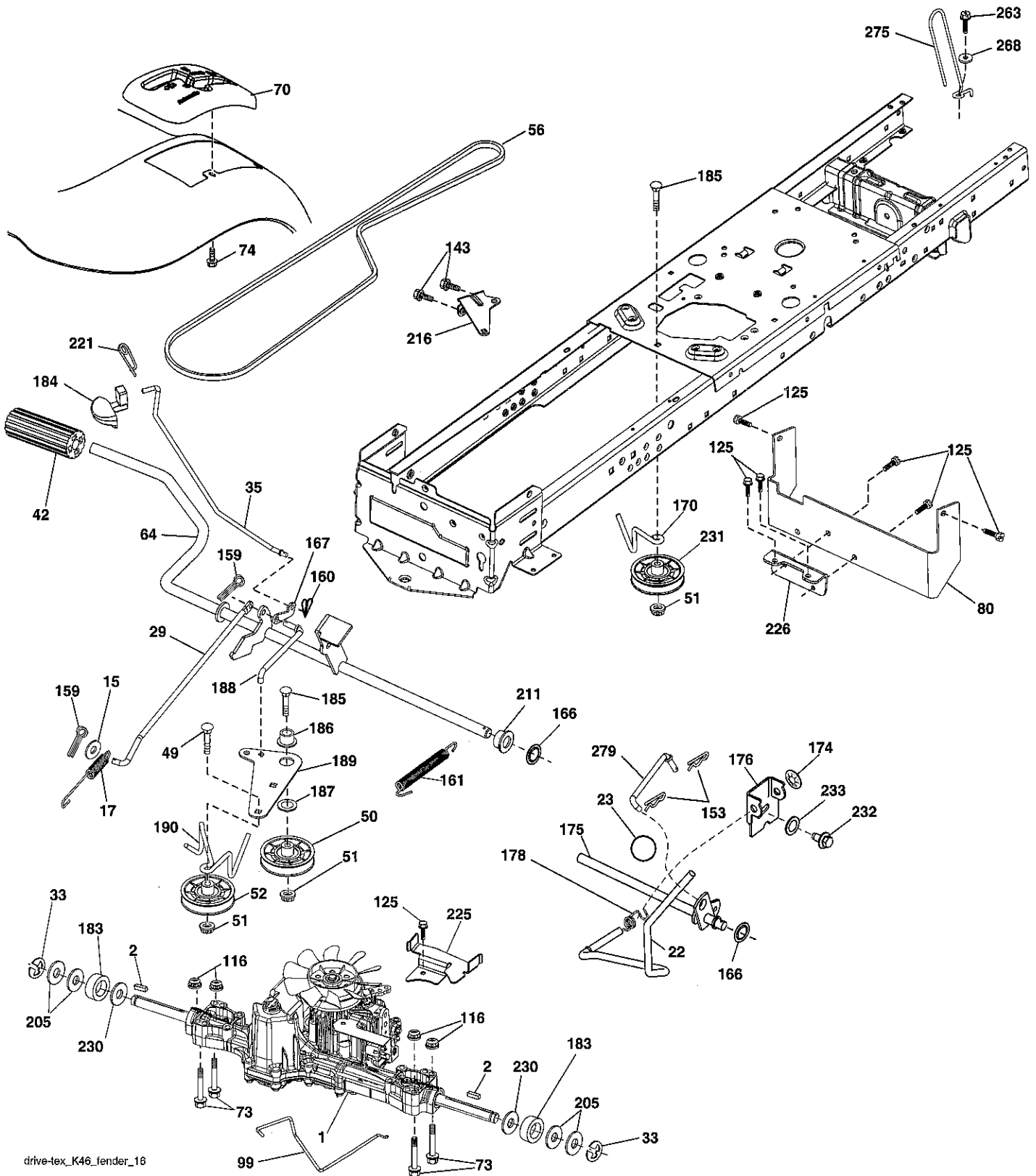

drive-tex_K46_tender_16

REPAIR PARTS

TRACTOR- -MODEL NO. 917.253653

DRIVE

KEY NO.	PART NO.	DESCRIPTION	KEY NO.	PART NO.	DESCRIPTION
1	-----	Transaxle Tufftorq K46BA (See Transaxle Breakdown)	170	413430	Keeper V-Idler
2	123583X	Key Square	174	197289	Nut Push
15	19131316	Washer 13/32 x 13/16 x 16 Ga.	175	408539	Shaft Asm Shift
17	413678	Spring, Brake	176	196214	Arm Clevis Rod Shift
22	197660	Rod Shift	178	197456	Spring Shift
23	106933X	Knob	183	137057	Spacer Axle
29	403806	Rod, Brake	184	199996X505	Handle Parking Brake
33	12000001	Ring E	185	72110622	Bolt
35	401031	Rod, Brake, Park Control	186	194321	Spacer Retainer
42	8883R	Cover, Foot Pedal	187	19133210	Washer
49	72110614	Bolt	188	194323	Link Clutch Ground Drive
50	194327	Pulley Idler Flat	189	194317	Bellcrank Ground Drive
51	73900600	Lock Nut 3/8-16	190	194318	Keeper Bellcrank Ground Drive
52	194326	Idler V-Groove 910" Offset	205	121748X	Washer 25/32 x 1-5/8 x 16 Ga.
56	130969	V-Belt, Drive	211	196212	Bushing
64	196200	Shaft Asm. Pedal Brake Control	216	196131	Bracket Pulley Idler
70	193220X428	Console	221	403187	Retainer Spring Clip Handle
73	74490544	Bolt Hex 5/16-18 Gr. 5	225	403319	Keeper Belt Transaxle
74	142432	Screw 1/4 x 1/2	226	401564	Bracket Mount Torque
80	410024	Strap Torque	230	188967	Washer Harden .793 x 1.637
99	415742	Rod Spring Bypass	231	407287	Idler V-Groove 1.688" Offset
116	73900500	Nut Lock Hex Flange 5/16-18	232	74780716	Bolt 7/16-14 x 1 Gr. 5
125	17000512	Screw 5/16-18 x 3/4	233	405296	Washer Serrated
143	17490508	Screw Thdrol 5/16-18 x 1/2	263	17000612	Screw Hexwsh Thdr 3/8-16 x 3/4
153	4497H	Retainer Spring 1"	268	19131614	Washer 13/32 x 1 x 14 Ga.
159	76020412	Pin Cotter 1/8 x 3/4	275	182402	Guard Muffler
160	169484	Retainer Clip	279	413150	Link Shift
161	105709X	Spring, Return, Clutch			
166	429164	Nut Push .625			
167	405257	Latch Brake Parking			

NOTE: All component dimensions given in U.S. inches
1 inch = 25.4 mm

REPAIR PARTS

TRACTOR- -MODEL NO. 917.253653

STEERING ASSEMBLY

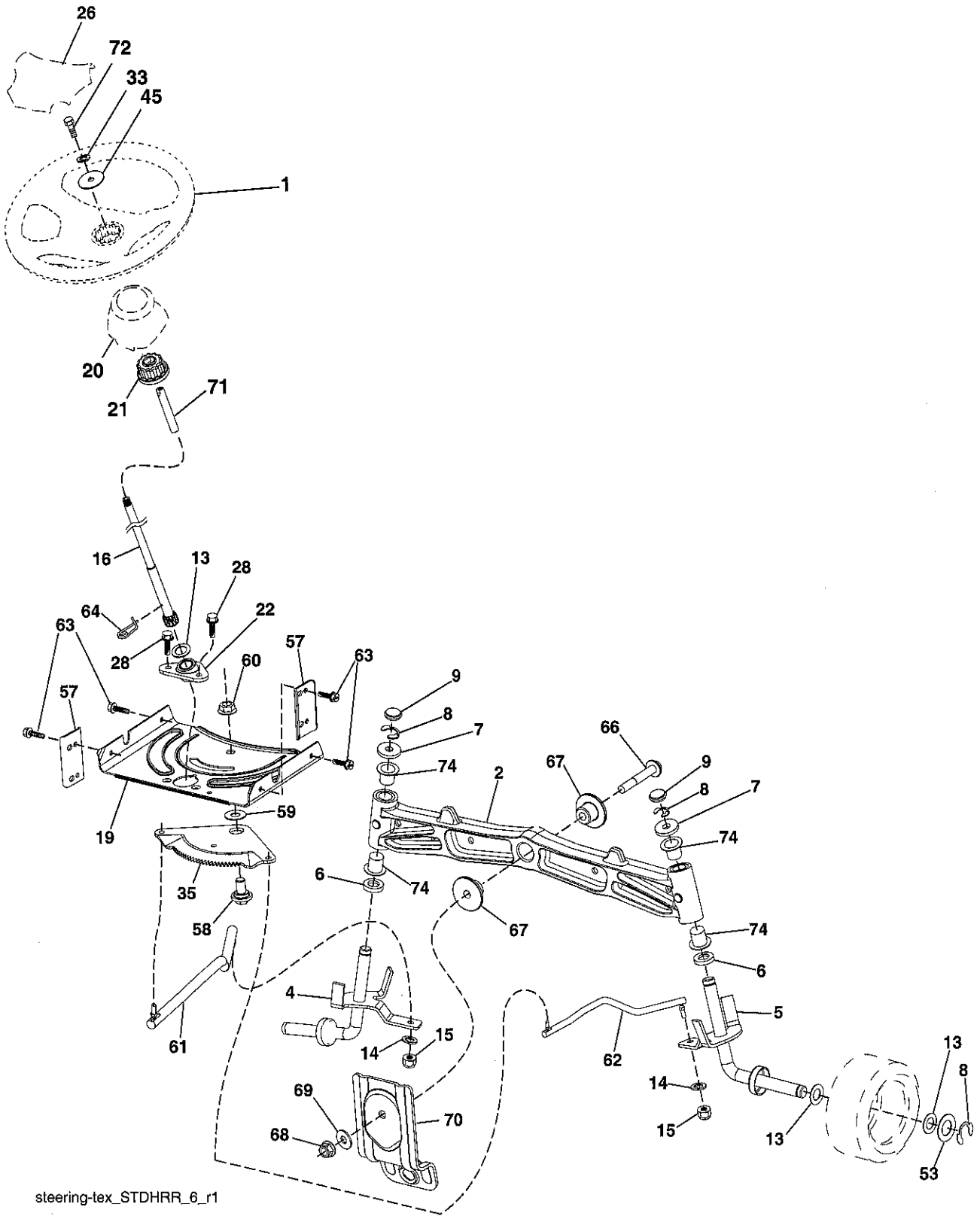

steering-tex_STDHRR_6_r1

REPAIR PARTS

TRACTOR- -MODEL NO. 917.253653

STEERING ASSEMBLY

KEY NO.	PART NO.	DESCRIPTION
1	414803X428	Wheel, Steering
2	418168	Axle Asm., Front
4	403087	Spindle Asm., LH
5	403088	Spindle Asm., RH
6	6266H	Washer Thrust
7	121748X	Washer 25/32 x 1-5/8 x 16 Ga.
8	12000029	Ring, Klip #T5304-75
9	121232X	Cap, Spindle
13	121749X	Washer 25/32 x 1-1/4 x 16 Ga.
14	STD551137	Washer, Lock Hvy Hlcl Spr 3/8
15	73540600	Nut, Crown Lock 3/8-24 unf
16	429373	Shaft Steering
19	194729	Plate Steering
20	400803X428	Boot, Steering
21	186737	Adapter, Wheel Steering
22	420537	Steering Supt. Lower
26	414852X428	Insert, Wheel Steering
28	17000612	Screw 3/8-16 x 3/4
33	10040500	Washer Lock Hvy HLCL Spr 5/16
35	194732	Gear, Sector Plate
45	19113812	Washer 11/32 ID x 2 3/8
53	188967	Washer Hardened .793 x 1.637 x .060
57	407465	Bracket Upstop
58	194747	Bolt Shoulder Sector Pivot CFM
59	194748	Washer Thrust Sector Steering
60	73971000	Nut Flange Lock 5/8-11
61	194740	Draglink LH
62	194741	Draglink, RH
63	17000512	Screw 5/16-18 x 3/4
64	199849	Retainer Clip Spring Steering
66	71020748	Bolt Hex Fghd 7/16-14 x 3 Serr
67	194737	Bushing PM Front Axle
68	73900700	Nut Lock Flange 7/16-14 Gr. 5
69	199162	Washer 1.5 x .505 x .118
70	196197	Bracket Deck Susp. Front
71	190752	Shaft Exten. Strg. Spline Tex
72	428982	Bolt Fin Hex 5/16-18 x 4
74	3366R	Bearing Col Strg Blk

NOTE: All component dimensions given in U.S. inches.
1 inch = 25.4 mm.

REPAIR PARTS

TRACTOR- -MODEL NO. 917.253653

SEAT ASSEMBLY

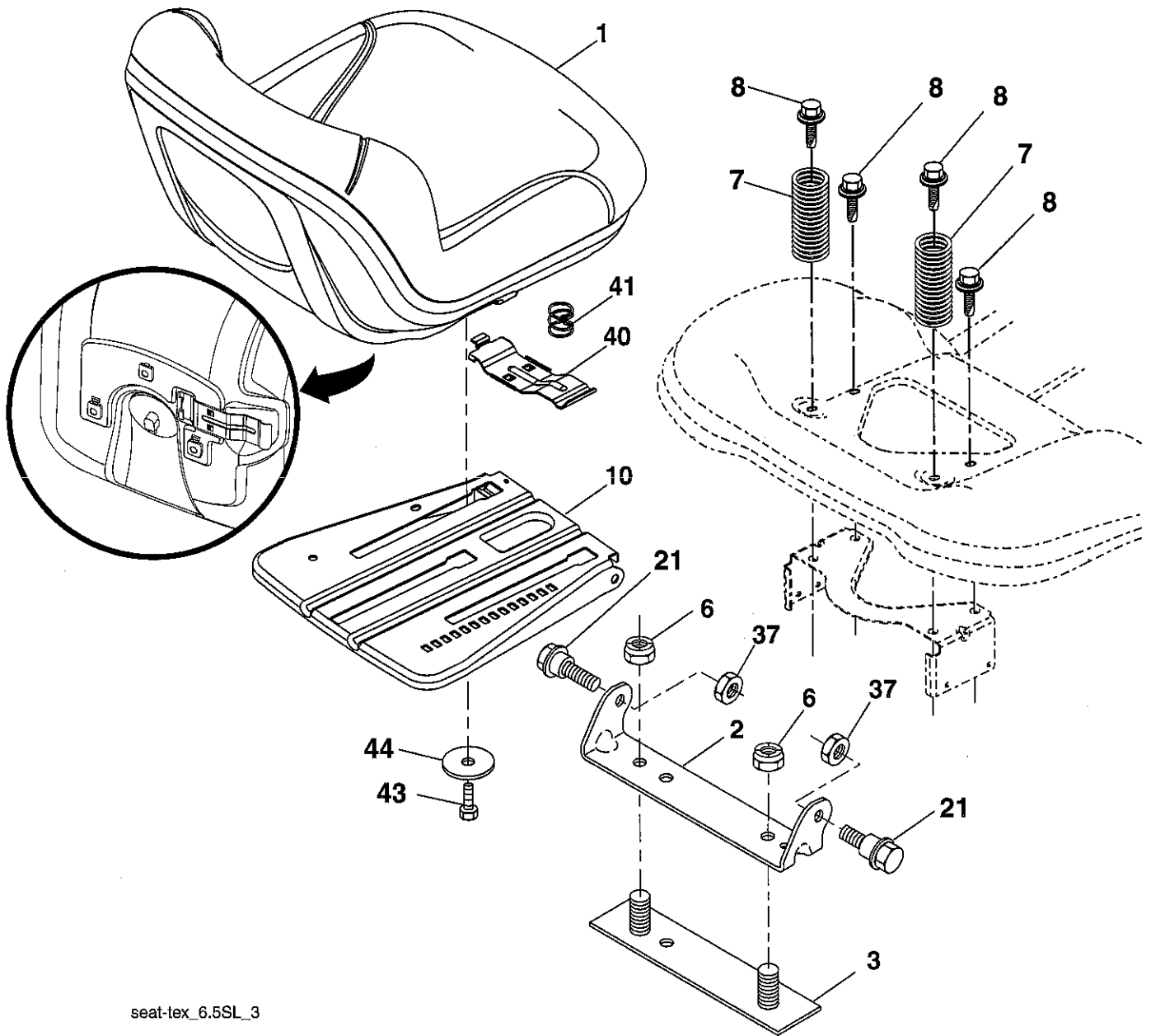

seat-tex_6.5SL_3

KEY NO.	PART NO.	DESCRIPTION
1	423644	Seat
2	180166	Bracket Pivot Fender
3	140675	Strap, Asm Fender
6	STD541437	Nut, Lock w/Ins. 3/8-16 unc
7	124181X	Spring, Seat Cprsn
8	171877	Bolt 5/16-18 unc x 3/4 w/Sems
10	196977	Pan, Seat
21	171852	Bolt, Shoulder 5/16-18

KEY NO.	PART NO.	DESCRIPTION
37	STD541431	Nut, Lock 5/16-18 unc
40	197661	Handle Slide
41	198200	Spring Latch
43	74760612	Bolt 3/8-16 unc x 3/4
44	19133812	Washer 13/32 x 2 3/8 x 12 Ga.

NOTE: All component dimensions given in U.S. inches.
1 inch = 25.4 mm

REPAIR PARTS

TRACTOR- -MODEL NO. 917.253653

DECALS

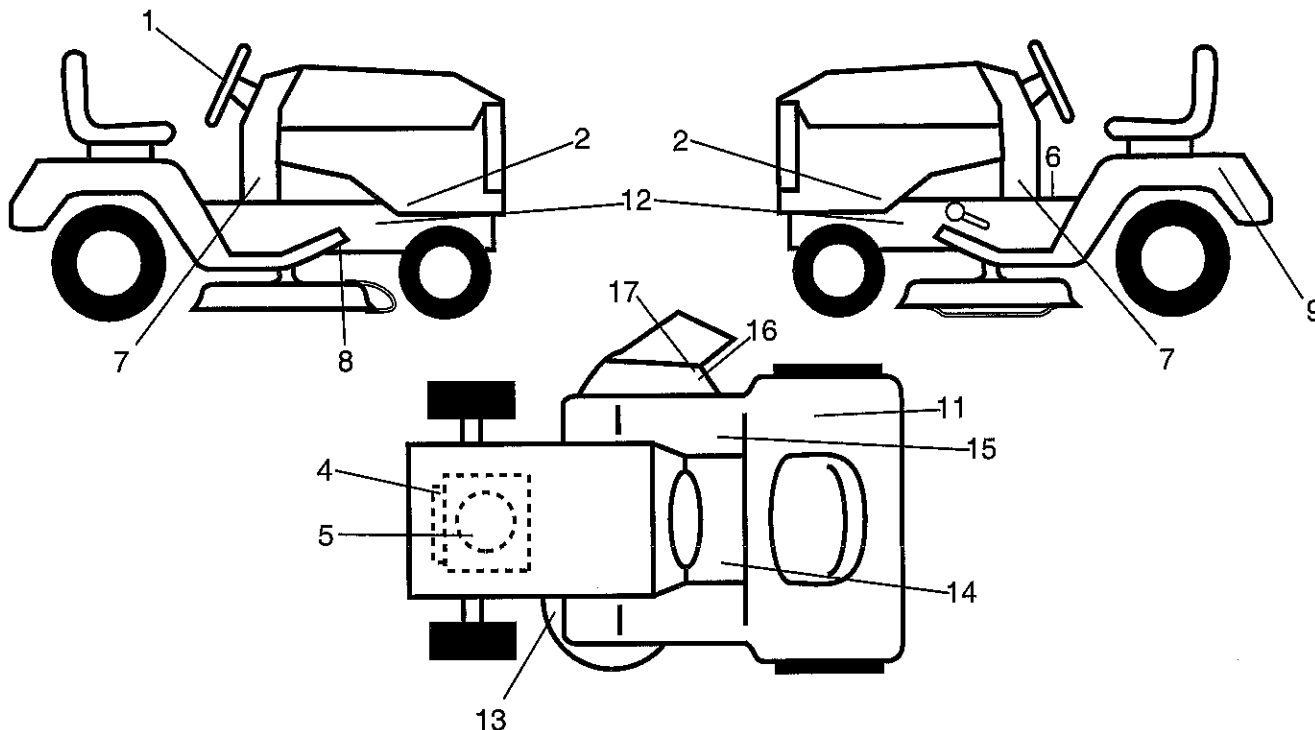

KEY NO.	PART NO.	DESCRIPTION	KEY NO.	PART NO.	DESCRIPTION
1	422885	Decal, Steering	15	140837	Decal, Saddle Brake Parking
2	433082	Decal, Panel SD	16	196357	Decal, Deflector Wrn. Cutfin. Sym.
4	196841	Decal, Warning Engine Sym.	17	182166	Decal, Cutfinger CE
5	432935	Decal, Engine HP	--	193226X428	Pad, Footrest LH
6	400389	Decal, Fender Operator's	--	193227X428	Pad, Footrest RH
7	425634	Decal, Lower Dash	--	166960	Decal, Bypass
8	421534	Decal, V-Belt Schematic Drive	--	162598	Decal, Drawbar Load Limit
9	145005	Decal, Battery Dnge/Poi	--	435185	Manual, Operator's (Euro)
11	180432	Decal, Fender 100 DB/CE	--	435186	Manual, Operator's (Scand)
12	159736	Decal, Chassis Hot Muffler	--	435187	Manual, Operator's (E-Bloc)
13	160396	Decal, Mower V-Belt SCH.	--	435188	Manual, Operator's (Baltic)
14	159737	Decal, Brake/Clutch Sym.	--	435525	Manual, Parts

WHEELS & TIRES

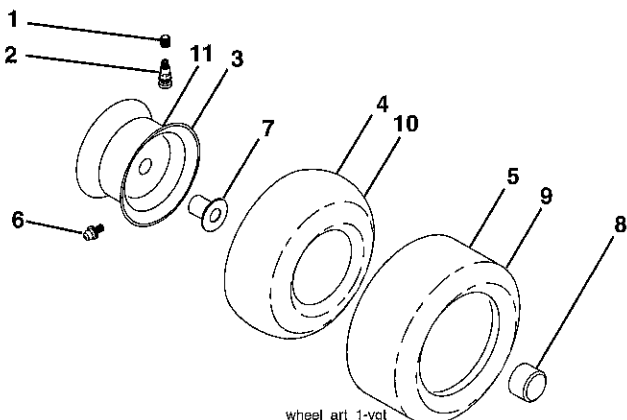

KEY NO.	PART NO.	DESCRIPTION
1	59192	Cap, Valve, Tire
2	65139	Stem, Valve
3	106732X613	Rim Assembly, Front
4	59904	Tube, Front
5	106222X	Tire, Front
6	278H	Fitting, Grease
7	9040H	Bearing, Flange
8	104757X428	Cap, Axle (Front Wheel Only)
9	420531	Tire, 18 x 9.5-8 TurfSaver LT
10	7152J	Tube, Rear
11	106108X613	Rim Assembly, Rear
--	144334	Sealant, Tire (10 oz. Tube)

NOTE: All component dimensions given in U.S. inches
1 inch = 25.4 mm

REPAIR PARTS

TRACTOR- -MODEL NO. 917.253653

ENGINE

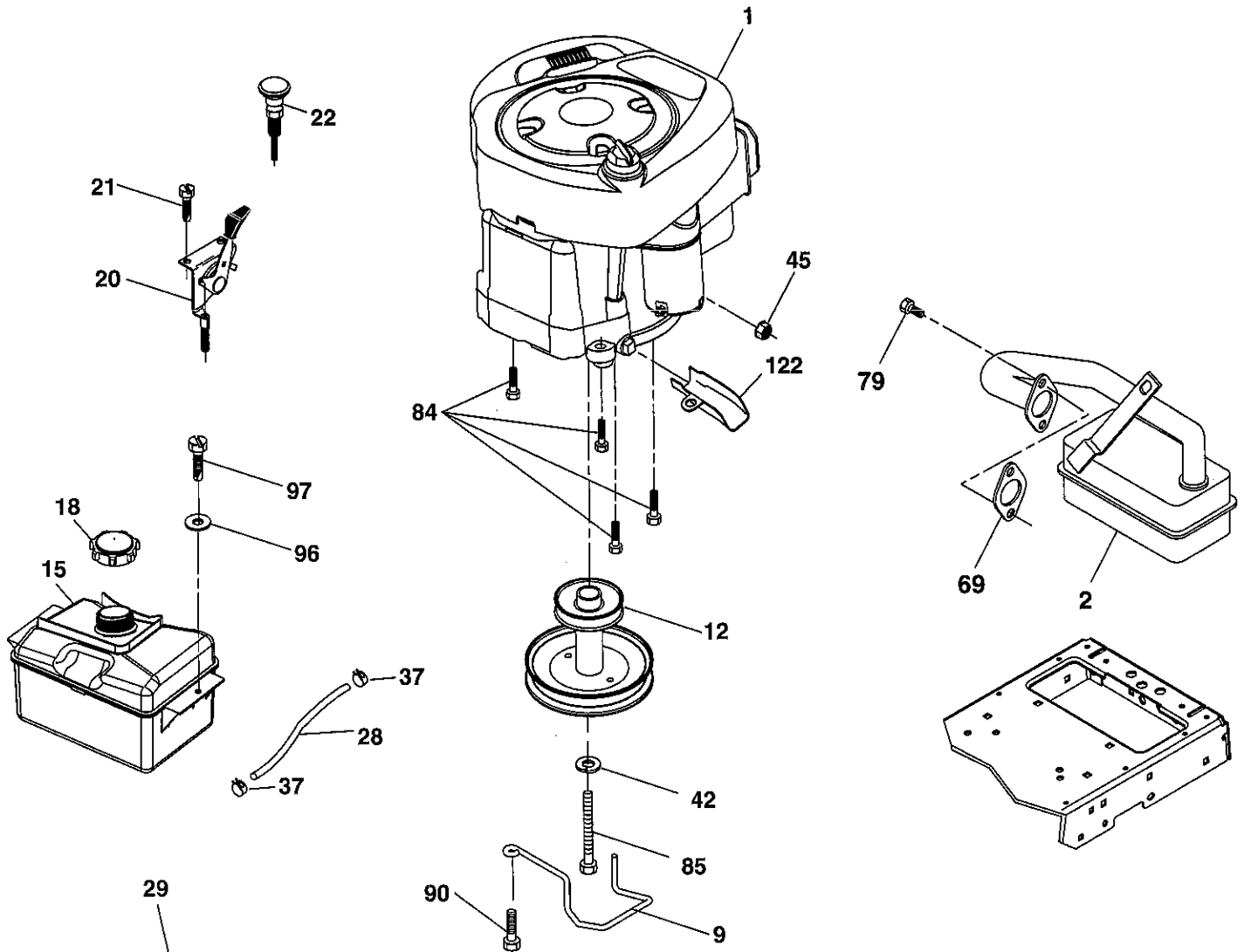

OPTIONAL EQUIPMENT
Spark Arrester

engine-tex_BS_35

REPAIR PARTS

TRACTOR- -MODEL NO. 917.253653

ENGINE

KEY NO.	PART NO.	DESCRIPTION
1	-----	Engine B&S Model No. 31C707-1429-B1
2	137352	Muffler
9	194320	Keeper Belt Engine
12	405471	Pulley Engine
15	407545	Tank Fuel 1.50
18	430220	Cap Asm
20	176636X428	Control Throttle
21	416358	Screw #10 x 0.750
22	187771X428	Control Choke
28	137040	Fuel Line
29	137180	Spark Arrester Kit
37	123487X	Clamp Hose
42	10040700	Washer Lock 7/16
45	73510400	Nut Keps Hex 1/4-20 unc
69	165291	Gasket
79	192334	Screw Socket Hd 5/16-18 x .75
84	17060620	Screw 3/8-16 x 1-1/4
85	173937	Bolt Hex 7/16-20 x 4 x Gr. 5-1.5
90	17000616	Screw 3/8-16 x 1.0
96	19091416	Washer 9/32 x 7/8 x 16 Ga.
97	17670412	Screw 1/4-20 x 3/4
122	421922	Extension Drain Oil

NOTE: All component dimensions given in U.S. inches
1 inch = 25.4 mm
For engine service and replacement parts, call the toll free number for your engine manufacturer listed below:

Briggs & Stratton 1-800-233-3723

Engine Power Rating Information

The gross power rating for individual gas engine models is labeled in accordance with SAE (Society of Automotive Engineers) code J1940 (Small Engine Power & Torque Rating Procedure), and rating performance has been obtained and corrected in accordance with SAE J1995 (Revision 2002-05). Torque values are derived at 3060 RPM; horsepower values are derived at 3600 RPM. Actual gross engine power will be lower and is affected by, among other things, ambient operating conditions and engine-to-engine variability. Given both the wide array of products on which engines are placed and the variety of environmental issues applicable to operating the equipment, the gas engine will not develop the rated gross power when used in a given piece of power equipment (actual "on-site" or net power). This difference is due to a variety of factors including, but not limited to, accessories (air cleaner, exhaust, charging, cooling, carburetor, fuel pump, etc.), application limitations, ambient operating conditions (temperature, humidity, altitude), and engine-to-engine variability. Due to manufacturing and capacity limitations, Briggs & Stratton may substitute an engine of higher rated power for this Series engine.

REPAIR PARTS

TRACTOR- -MODEL NO. 917.253653

MOWER LIFT

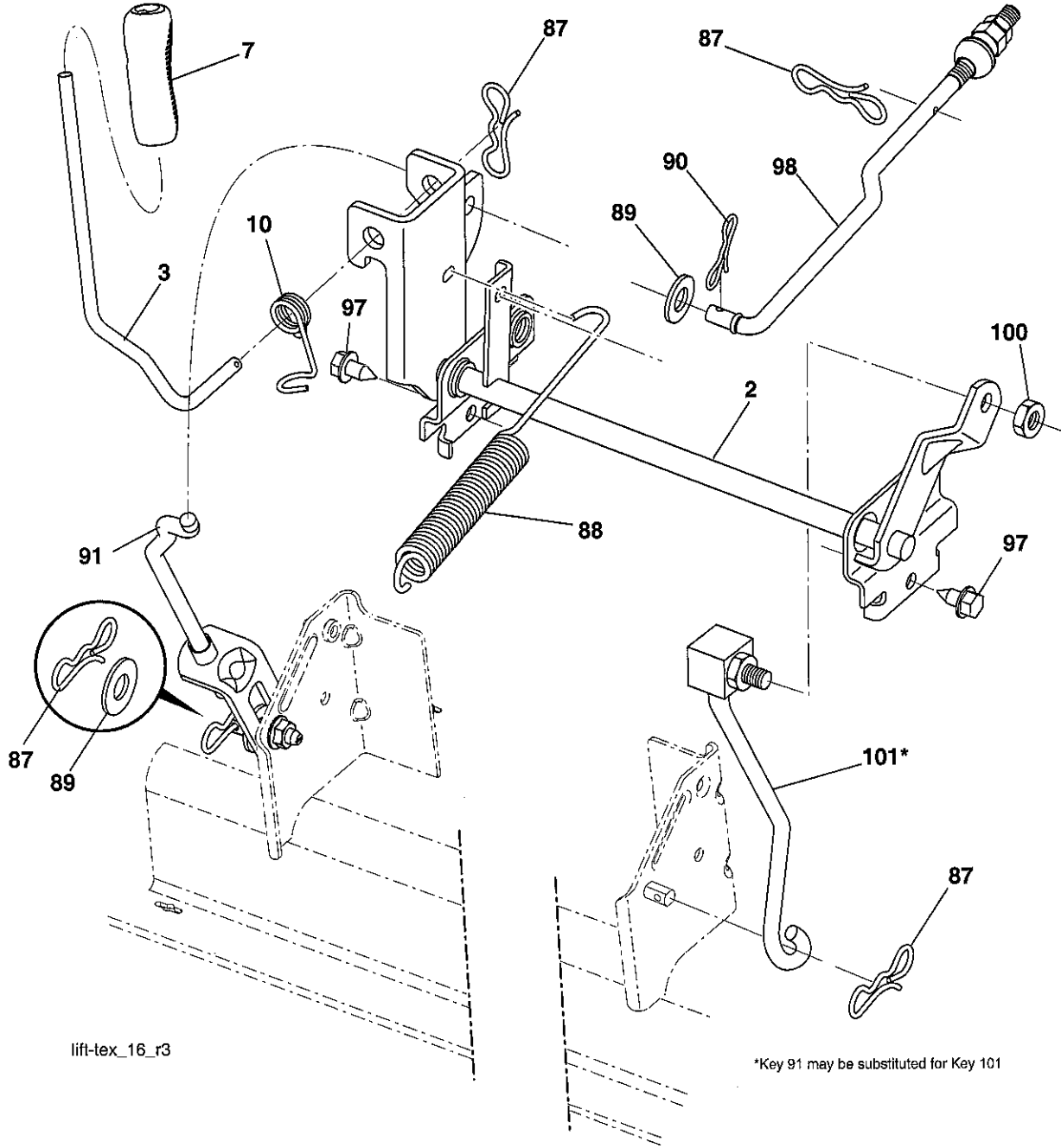

lift-tex_16_r3

*Key 91 may be substituted for Key 101

REPAIR PARTS

TRACTOR- -MODEL NO. 917.253653

MOWER LIFT

KEY NO.	PART NO.	DESCRIPTION
2	422027	Shaft Asm., Lift
3	195231	Lever Asm., Lift RH
7	196492X428	Grip, Lever
10	196314	Spring Torsion
87	194209	Pin Cotter 7/16 Bow Tie Lock
88	410710	Spring Lift Assist
89	19191912	Washer Clear Zinc
90	194208	Pin Cotter 5/16 Bow Tie Lock
91	195181	Link Lift Susp Mower Rear
97	17000612	Screw 3/8-16 x .75
98	195270	Link Lift Susp. Front Mower
100	73930600	Nut Centerlock 3/8-16 unc
101	407003	Link Asm. Lift FXD

NOTE: All component dimensions given in U.S. inches
1 inch = 25.4 mm

REPAIR PARTS

TRACTOR- -MODEL NO. 917.253653

MOWER

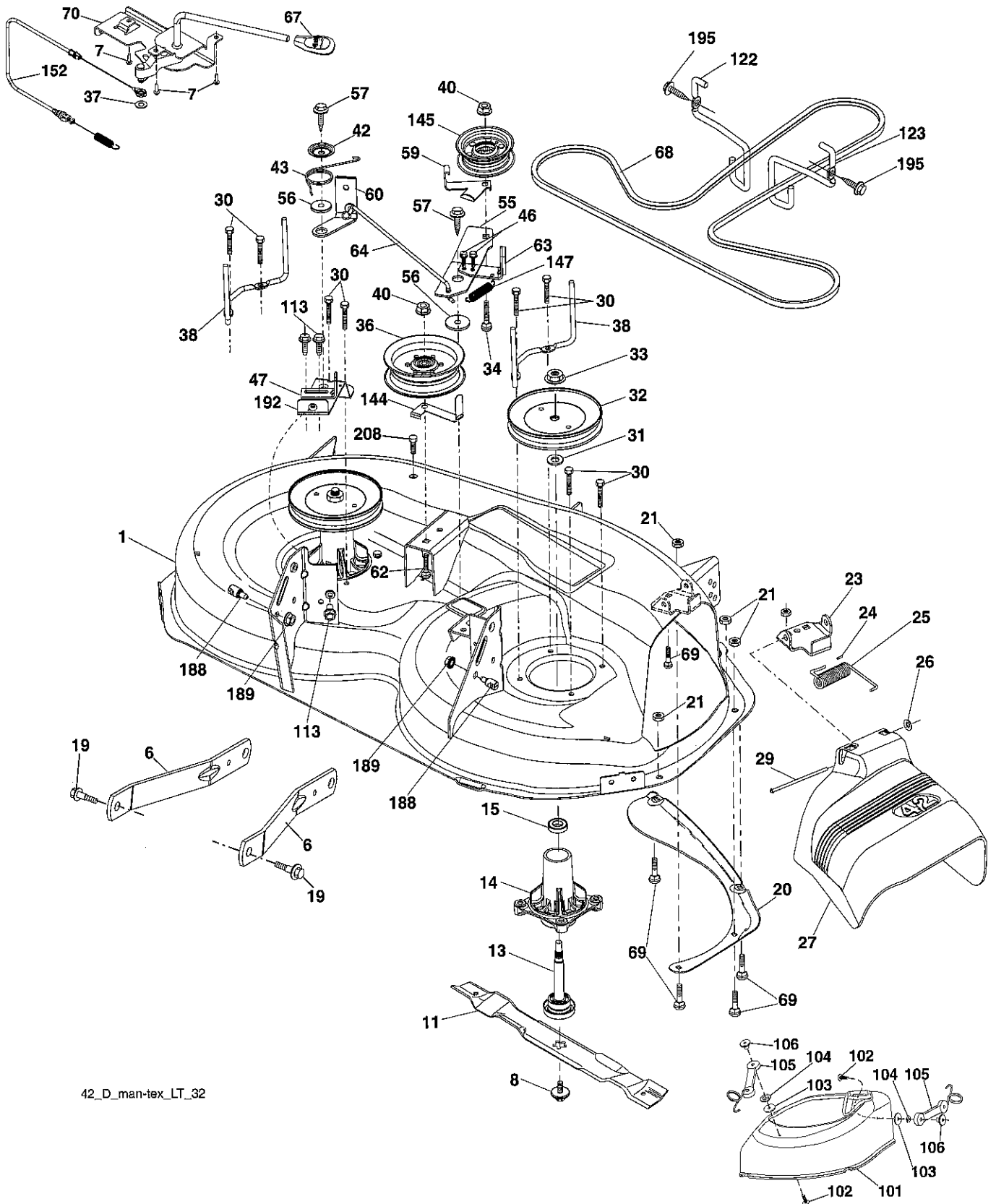

42_D_man-tex_LT_32

REPAIR PARTS

TRACTOR- -MODEL NO. 917.253653

MOWER

KEY NO.	PART NO.	DESCRIPTION	KEY NO.	PART NO.	DESCRIPTION
1	199911	Mower Housing	62	72110616	Bolt Rdhd Sqnk 3/8-16 unc x 2
6	195186	Arm Suspension	63	199477	Arm Brake Mower
7	416358	Screw 10 x .750 BOS Thread	64	199790	Linkage Brake
8	193003	Bolt/Washer Asm 7/16-20 unf	67	198398X428	Handle, Clutch Cable
11	424752	Blade, 3N1	68	429636	V-Belt
13	192872	Shaft Assembly, Mandrel	69	72140505	Bolt Rdhd Sqnk 5/16-18 x 5/8
14	187281	Housing, Mandrel	70	401246	Clutch Asm. Manual
15	110485X	Bearing, Ball, Mandrel	101	193107	Cover Mulching
19	196539	Bolt, Shoulder	102	71081010	Screw Pan Hd. Phillip 10-24 x 5/8
20	159770	Baffle Vortex	103	19061216	Washer #10
21	73680500	Nut, Crownlock 5/16-18 unc	104	10071000	Washer Lock #10
23	192557	Bracket, Deflector	105	160793	Latch Asm.
24	105304X	Cap, Sleeve	106	2029J	Nut Weld 327/304 #10-24
25	197026	Spring, Torsion, Deflector	113	17000510	Screw 5/16-18
26	110452X	Nut, Push	122	197258	Keeper Belt Eng. LH
27	424469	Shield, Deflector	123	197259	Keeper Belt Eng. RH
29	131491	Rod, Hinge	144	199204	Keeper Belt
30	173984	Screw Thdrol Rolling Wsh Hd	145	193197	Pulley, Idler, Flat
31	187690	Washer, Spacer	147	401971	Spring Return
32	197473	Pulley, Mandrel	152	408714	Cable Clutch Manual w/Spr.
33	400234	Nut, Toplock, Flanged	188	195161	Stud Fastener
34	72110612	Bolt Carr Sh. 3/8-16 x 1-1/2 Gr. 5	189	73900500	Nut Lock Hex Flange
36	197379	Pulley Idler	192	197260	Bracket Brake Stand LH
37	19131316	Washer 13/32 x 13/16 x 16 Ga.	195	17000612	Screw Hexwsh Thdr 3/8-16 x 3/4
38	199189	Keeper Belt LH Mandrel	208	17670608	Screw 3/8-16 x 1/2
40	73900600	Nut, Lock Flg. 3/8-16 unc	--	426340	Replacement Mower, Complete
42	197256	Spring Torsion Retainer	--	192870	Mandrel Assembly (Mandrel As- sembly (Includes housing, shaft assembly, and bearing only - pulley/ nut/washer and blade bolt/washers not included)
43	198410	Spring Torsion Brake			
46	137729	Screw Thd Roll 1/4-20 x 5/8			
47	197250	Bracket Clutch Cable			
55	197249	Arm, Idler			
56	199092	Spacer, Retainer			
57	17000616	Screw Hexwsh Thd 3/8-16 x 1			
59	141043	Guard, Tuv Idler (94)			
60	197261	Arm Brake Mower			

NOTE: All component dimensions given in U.S. inches
1 inch = 25.4 mm

TRACTOR - - MODEL NUMBER 917.253653

TUFFTORQ TRANSAXLE - MODEL NUMBER K46BA

MODEL K46BA
7A646084100

ACTUAL PARTS
MAY NOT APPEAR
AS SHOWN

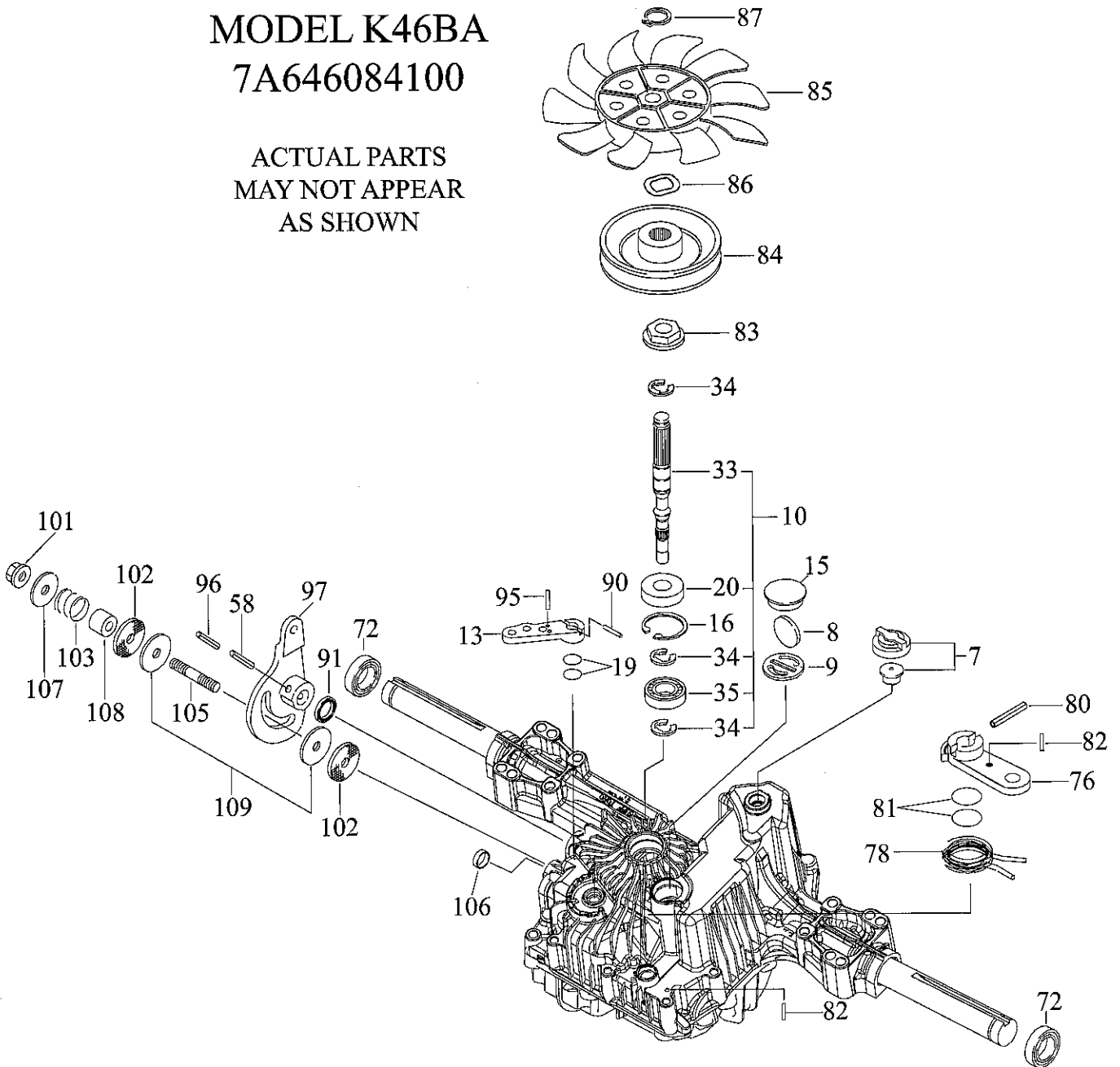

TRACTOR - - MODEL NUMBER 917.253653**TUFFTORQ TRANSAXLE - MODEL NUMBER K46BA**

KEY NO.	PART NO.	DESCRIPTION
7	414395	VENT VALVE 15
8	414396	MAGNET
9	414397	MAGNET HOLDER
10	415923	PUMP SHAFT/BEARING KIT
13	414398	BYPASS LEVER
15	414399	SEALING CAP 30
16	414400	SNAP RING C 35
19	414401	O-RING 1A P10A
20	414402	SEAL TC 153507
33	414403	PUMP SHAFT (STANDARD
34	414404	E-RING 15
35	414405	BEARING 6202C3
58	414406	ROLL PIN 6 * 40
72	414407	SEAL 19 * 32 * 8
76	414408	BRAKE LEVER
78	414409	BRAKE RETURN SPRING
80	414410	SPRING PIN 5 * 32
81	414411	O-RING 1A P12
82	414412	SPRING PIN 4 * 16
83	414413	SPINE COLLAR
84	414414	PULLEY L
85	414415	FAN, BLACK
86	414416	WAVE WASHER
87	414417	SNAP RING
90	414418	SPRING PIN 3.0A * 20
91	414419	OIL SEAL 16 * 22 * 03
95	415850	SPRING PIN 3.0A * 16
96	414420	ROLL PIN 3.5 * 40
97	414421	CONTROL LEVER
101	414216	LOCK NUT 10
102	414423	WASHER 10 * 40 * 4
103	414424	SPRING
105	414425	STUD 10 * 60
106	414426	SEALING CAP 18
107	414427	WASHER 10 * 36 * 2.8
108	414428	COLLAR 10 * 20 * 17
109	414429	FRICTION PLATE KIT

NOTE: All component dimensions given in U.S. inches
1 inch = 25.4 mm

REPAIR PARTS

TRACTOR- -MODEL NO. 917.253653

BRIGGS & STRATTON ENGINE - - MODEL NUMBER 31C707, TYPE NUMBER 1429-B1

48 SHORT BLOCK

1036 EMISSIONS LABEL

1058 OPERATOR'S MANUAL

1329 REPLACEMENT ENGINE

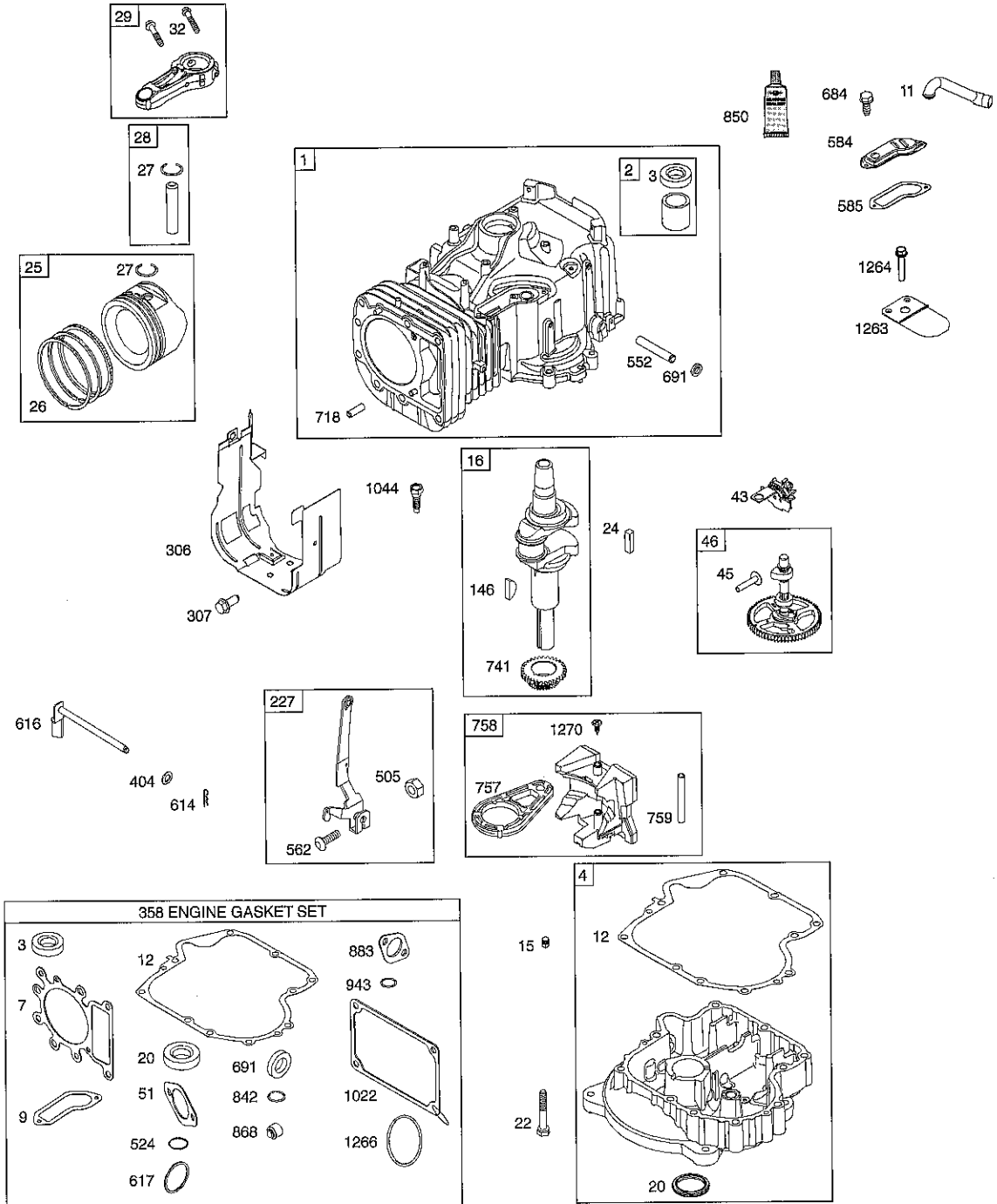

REPAIR PARTS

TRACTOR- -MODEL NO. 917.253653

BRIGGS & STRATTON ENGINE - - MODEL NUMBER 31C707, TYPE NUMBER 1429-B1

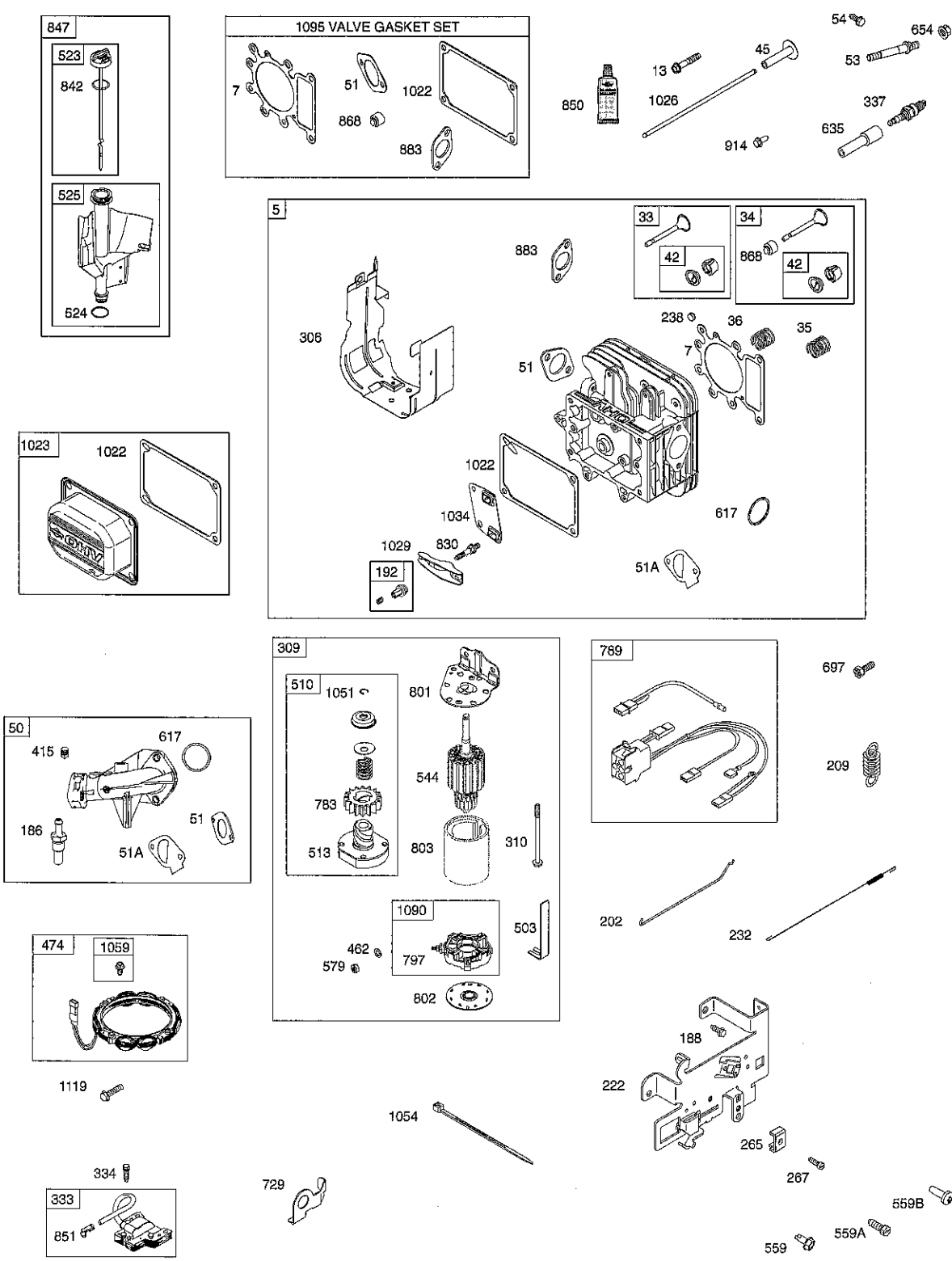

REPAIR PARTS

TRACTOR- -MODEL NO. 917.253653

BRIGGS & STRATTON ENGINE - - MODEL NUMBER 31C707, TYPE NUMBER 1429-B1

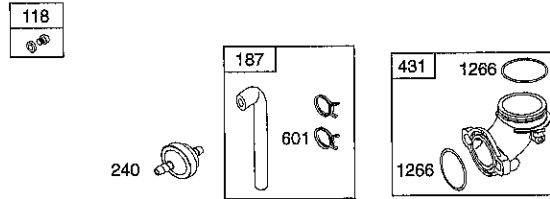
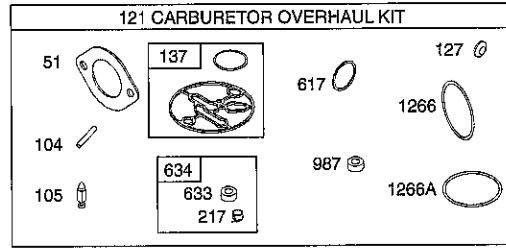
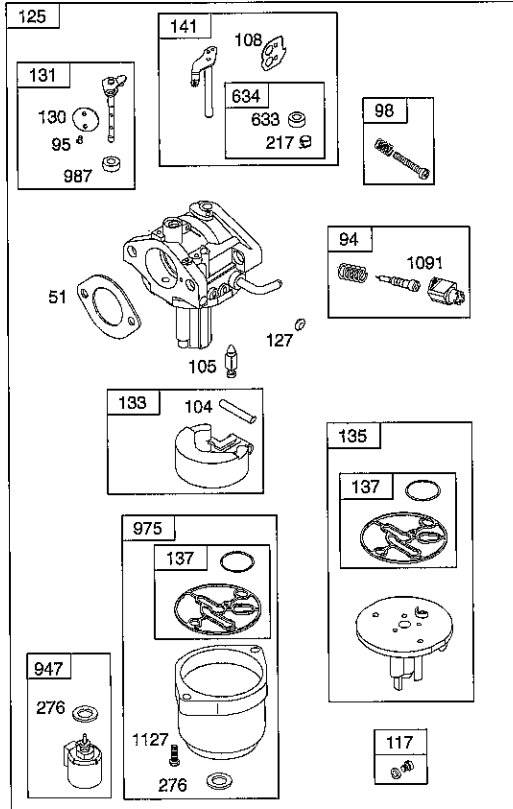

1036 EMISSIONS LABEL

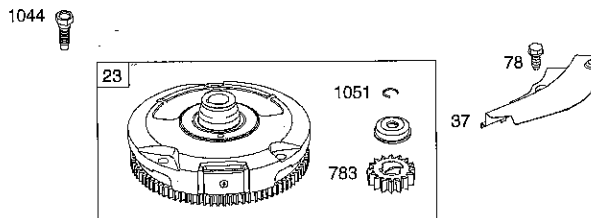
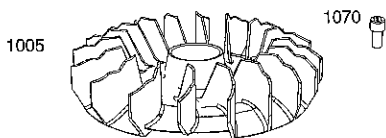
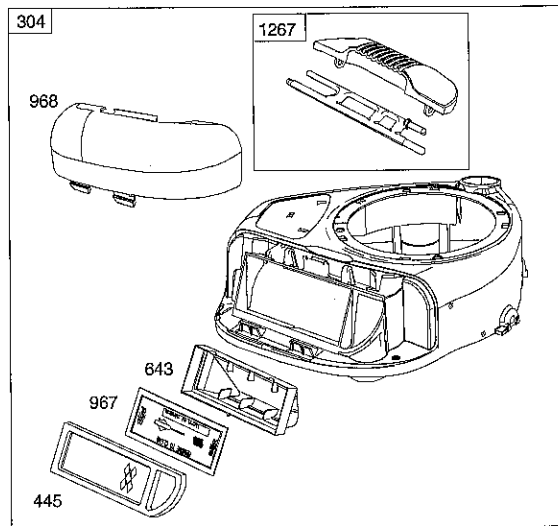
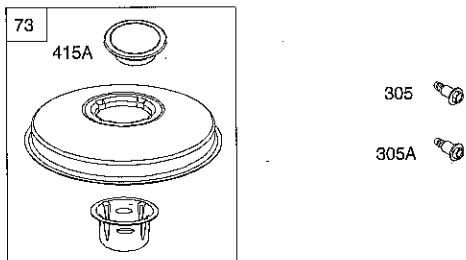

REPAIR PARTS

TRACTOR- -MODEL NO. 917.253653

BRIGGS & STRATTON ENGINE - - MODEL NUMBER 31C707, TYPE NUMBER 1429-B1

KEY NO.	PART NO.	DESCRIPTION	KEY NO.	PART NO.	DESCRIPTION
1	796010	Cylinder Assembly	108	695419	Valve-Choke
2	399265	Bushing/Seal Kit (Magneto Side)	117	843099	Jet-Main (Standard)
3	391086s	• Seal-Oil (Magneto Side)	118	790890	Jet-Main (High Altitude)
4	697106	Sump-Engine	121	796184	Kit-Carburetor Overhaul
5	796025	Head-Cylinder	125	796109	Carburetor
7	796584	•∅ Gasket-Cylinder Head	127	690727	+ Plug-Welch
11	794683	Tube-Breather	130	699500	Valve-Throttle
12	697110	• Gasket-Crankcase	131	699501	Kit-Throttle Shaft
13	793988	Screw (Cylinder Head)	133	694914	Float-Carburetor
15	690946	Plug-Oil Drain	135	698780	Tube-Fuel Transfer
16	797579	Crankshaft	137	698781	+ Gasket-Float Bowl
20	795387	• Seal-Oil (PTO Side)	141	792777	Kit-Choke Shaft
22	692125	Screw (Crankcase Cover/ Sump)	146	691639	Key-Timing
23	698281	Flywheel	186	794873	Connector-Hose (Intake Manifold)
24	222698s	Key-Flywheel	187	791805	Line-Fuel (Formed)(Cut to
25	796172	Piston Assembly (Standard)			Required Length)
	796173	Piston Assembly (.020" Oversize)	188	691693	Screw (Control Bracket)
26	791936	Ring Set (Standard)	192	691986	Adjuster-Rocker Arm
	792649	Ring Set (.020" Oversize)	202	691841	Link-Mechanical Governor
27	698469	Lock-Piston Pin	209	692208	Spring-Governor (Green)
28	796007	Pin-Piston	217	695409	Spring-Choke Return
29	794122	Rod-Connecting	222	694042	Bracket-Control
32	791118	Screw (Connecting Rod)	227	691374	Lever-Governor Control
33	792868	Valve-Exhaust	232	691842	Spring-Governor Link
34	791935	Valve-Intake	238	691843	Cap-Valve
35	691279	Spring-Valve (Intake)	240	394358s	Filter-Fuel
36	691279	Spring-Valve (Exhaust)	265	691024	Clamp-Casing
37	697352	Guard-Flywheel	267	794904	Screw (Casing Clamp)
42	499586	Keeper-Valve	276	695410	Washer-Sealing
43	691968	Slinger-Governor/Oil	304	796416	Blower Housing
45	690564	Tappet-Valve	305	697102	Screw (Blower Housing)(Long)
46	793880	Gear-Cam	305A	793376	Screw (Blower Housing)(Short)
48		Short Block	306	796006	Shield-Cylinder
50	796180	Manifold-Intake	307	691003	Screw (Cylinder Shield)
51	692137	•∅+ Gasket-Intake	309	693551	Motor-Starter
51A	796081	Gasket-Intake	310	690323	Screw (Starter Motor)
53	690227	Stud (Carburetor)	324	796308	Screen/Cup Assembly
54	691148	Screw (Intake Manifold)	333	795315	Armature-Magneto
78	691003	Screw (Flywheel Guard)	334	691061	Screw (Magneto Armature)
94	793610	Kit-Idle Mixture	337	691043	Plug-Spark
95	690718	Screw (Throttle Valve)	358	796187	Gasket Set-Engine
98	695408	Kit-Idle Speed	404	691691	Washer (Governor Crank)
104	694918+	Pin-Float Hinge	415	690283	Plug (Intake Manifold)
105	696136+	Valve-Float Needle	415A	794129	Plug (Cover/Retainer)

REPAIR PARTS

TRACTOR- -MODEL NO. 917.253653

BRIGGS & STRATTON ENGINE - - MODEL NUMBER 31C707, TYPE NUMBER 1429-B1

KEY NO.	PART NO.	DESCRIPTION	KEY NO.	PART NO.	DESCRIPTION
431	697122	Elbow-Intake	850	100106	Sealant-Liquid (Liquid Sealant is interchangeable with Breather Passage Gasket and/or Rocker Cover Gasket)
445	797008	Filter-Air Cleaner Cartridge			
462	691261	Washer (Starter Cable)			
474	696459	Alternator			
503	691532	Strap-Starter	851	692424	Terminal-Spark Plug
505	691251	Nut (Governor Control Lever)	868	690968	∅• Seal-Valve
510	693699	Drive-Starter	883	692236	• Gasket-Exhaust
513	692024	Clutch-Drive	914	697551	Screw (Rocker Cover)
523	699908	Dipstick	947	699915	Solenoid-Fuel
524	691032	• Seal-Dipstick Tube	967	697015	Filter-Pre Cleaner
525	697184	Tube-Dipstick	968	698403	Cover-Air Cleaner
544	693551	Armature-Starter (Order Starter Motor, Reference 309, for replacement)	975	699502	Bowl-Fuel
			987	698777	+ Seal-Throttle Shaft
552	697144	Bushing-Governor Crank	1005	796083	Fan-Flywheel
562	691119	Screw (Governor Control Lever)	1022	272475s	∅• Gasket-Rocker Cover
579	691029	Nut (Starter Cable)	1023	797421	Cover-Rocker
584	794682	Cover-Breather Passage (Use with Liquid Sealant, Reference 850)	1026	692003	Rod-Push (Intake)
				692011	Rod-Push (Exhaust)
			1029	691751	Arm-Rocker
585	697109	• Gasket-Breather Passage	1034	690822	Guide-Push Rod
601	791850	Hose-Clamp (Green)	1036		Label-Emissions (Available from a Briggs & Stratton Authorize-Dealer)
614	691620	Pin-Cotter			
616	692012	Crank-Governor	1040	698368	Plate-Trim
617	692138	•+ Seal-O Ring (Intake Manifold) (Red)	1044	698139	Screw (Flywheel)
			1051	691265	Ring-Retaining
633	699813	Seal-Choke/Throttle Shaft (Choke Shaft)	1054	280275	Tie-Cable
			1059	698516	Kit-Screw/Washer
634	698779	+ Spring/Seal Assembly(Choke Shaft)	1070	690363	Screw (Flywheel Fan)
			1090	691293	Retainer-Brush
635	691909	Boot-Spark Plug	1091	691333	Cap-Limiter
643	698401	Retainer-Air Filter	1095	794152	Gasket Set-Valve
654	690958	Nut (Carburetor)	1119	691183	Screw (Alternator)
684	697157	Screw (Breather Assembly)	1127	695407	Screw (Float Bowl)
691	692407	• Seal-Governor Shaft	1263	697124	Reed-Breather
718	690959	Pin-Locating	1264	697104	Screw (Breather Reed)
724	697478	Link-Starter Switch	1266	691917	•+ Seal-O Ring (Intake Elbow) (Red)
729	691224	Clip-Wire			
741	697128	Gear-Timing	1266A	697123	+ Seal-O Ring (Intake Elbow)
757	793242	Link-Counterweight	1267	697419	Latch-Blower Housing
758	793763	Counterweight	1270	793243	Plug-AVS Counterweight
759	697392	Pin-Counterweight	1329		Replacement Engine
783	693713	Gear-Pinion	1330	272147	Repair Manual
789	698329	Harness-Wiring			
797	693167	Nut (Brush Retainer)	•	Engine Gasket Set	Key No. 358
801	691283	Cap-Drive	∅	Valve Gasket Set	Key No. 1095
802	691286	Cap-End	+	Carburetor Overhaul Kit	Key No. 121
803	693551	Housing-Starter (Order Starter Motor, Reference 309, for replacement)			
830	691095	Stud-Rocker Arm			
842	691031	• Seal-O Ring (Dipstick Tube)			
847	790442	Dipstick/Tube Assembly			

NOTE: All component dimensions given in U.S. inches
1 inch = 25.4 mm

GENERAL: Craftsman products are warranted to be free from defects in materials or workmanship for a specific time period as set-out below (the "Warranty Period"). Warranties extend to the original purchaser of a Craftsman product only. Purchases made through an online auction or through any website other than www.sears.ca are excluded. The relevant Warranty Period commences on the original date of purchase. Within this period, SEARS CANADA, Inc. will, at its sole option, repair or replace any products or components which fail in normal use. Such repairs or replacement will be made at no charge to the customer for parts or labor, provided that the customer shall be responsible for any transportation cost.

EXCLUSIONS: This warranty does not cover failures due to normal wear, abuse, misuse, neglect (including but not limited to the use of stale fuel, dirt, abrasives, moisture, rust, corrosion, or any adverse reaction due to improper storage or use habits), improper maintenance or failure to follow maintenance guidelines and/or instructions, failure to operate the product in accordance with the owner's manual or any additional instructions or information provided at the time of purchase or in subsequent communications with the original purchaser, accident or unauthorized alterations or repairs made or attempted by others. Also excluded from warranty coverage - except as provided below - are the following: maintenance, adjustments, components subject to wear including but not limited to: cosmetic components, belts, blades, blade adapters, bulbs, tires, filters, guide bars, lubricants, seats, grips, recoil assy's, saw chains and bars, trimmer lines and spools, spark plugs, starter ropes and tines, and discoloration resulting from ultraviolet light. Any product missing the model and/or serial number identification label will be disqualified from coverage under this warranty.

REPAIRS: Repairs have a 90 day warranty. If the defective product is still within the Warranty Period, then the new warranty is 90 days from the date of repair or to the end of the original Warranty Period, whichever period is longer.

DISCLAIMERS: THE WARRANTIES AND REMEDIES CONTAINED HEREIN ARE EXCLUSIVE AND IN LIEU OF ALL OTHER WARRANTIES, WHETHER ORAL OR WRITTEN (OTHER THAN AS STATED HEREIN), AND WHETHER EXPRESS, IMPLIED OR STATUTORY, INCLUDING BUT NOT LIMITED TO ANY. THIS WARRANTY GIVES YOU SPECIFIC LEGAL RIGHTS, WHICH MAY VARY FROM PROVINCE TO PROVINCE.

IN NO EVENT SHALL SEARS BE LIABLE FOR ANY INCIDENTAL, SPECIAL, INDIRECT OR CONSEQUENTIAL DAMAGES, WHETHER RESULTING FROM THE USE, MISUSE OR INABILITY TO USE THE PRODUCT OR FROM DEFECTS IN THE PRODUCT. THE EXCLUSIONS IN THIS PARAGRAPH SHALL NOT APPLY IN JURISDICTIONS WHERE APPLICABLE LAW DOES NOT ALLOW FOR THE EXCLUSION OF INCIDENTAL OR CONSEQUENTIAL DAMAGES. IN SUCH JURISDICTIONS, THIS PARAGRAPH SHALL NOT APPLY, BUT THE REMAINING PROVISIONS OF THIS DOCUMENT SHALL REMAIN VALID.

SEARS retains the exclusive right to repair or replace the product or offer a full refund of the purchase price at its sole discretion. SUCH REMEDY SHALL BE YOUR SOLE AND EXCLUSIVE REMEDY FOR ANY BREACH OF WARRANTY.

CUSTOMER RESPONSIBILITIES: In addition to complying with all suggested maintenance guidelines and instructions, customers' obligations shall include but shall not be limited to: operating the product in accordance with the owner's manual or any additional instructions or information provided at the time of purchase or in subsequent communications to the purchaser from time to time, exhibit reasonable care in the use, operation, maintenance, general upkeep and storage of the product. Failure to comply with these requirements will void any applicable warranty.

LIST OF APPLICABLE WARRANTY PERIODS: The following list contains the applicable Warranty Period for your Craftsman product and is based on a combination of the type of product or component and the intended and actual use of the product or component:

1. **90 DAYS:** Craftsman products intended for use or actually used for commercial, institutional, professional or income-producing purposes
2. **2 YEARS:** Craftsman riding lawn mowers, yard and garden tractors, walk behind mowers, tillers, brush cutters, snow blowers, handheld blowers, backpack blowers, hedge trimmers and electrical products for noncommercial, nonprofessional, non-institutional, or non-income-producing use, except for those components which are part of engine systems manufactured by third party engine manufacturers for which the purchase has received an separate warranty with product information supplied at the time of purchase.
3. **1 YEAR:** Craftsman power cutters, stump grinders, pole pruners, gas chain saws, electric chain saws, trimmer attachments, baggers and pole saws for noncommercial, nonprofessional, non-institutional, or non-income-producing use.
4. **90 DAYS:** All defective batteries, which will be replaced during this 90-day Warranty Period.
5. **60 DAYS:** Additional Warranty Period of 60 days will apply to adjustments and worn products or components BUT DOES NOT INCLUDE WEAR OR ADJUSTMENTS for products used for commercial, institutional, professional or income-producing purposes. Wear items include but are not limited to: belts, blades, tires, spark plugs, air filters, chains, shear bolts, skid plates, scraper bars, drift cutters, ropes, tines, collection bags and pulleys.

As the Warranty Period runs from the date of purchase and NOT from the date that a product is delivered, opened, assembled or first used, please ensure during this time period that your product or component has been assembled and tested for correction operation regardless of when you intend to actually use it. Claims made after the Warranty Period has expired will not be honored.

PROOF OF PURCHASE/DOCUMENTATION: Warranty coverage is conditioned upon the original purchaser furnishing SEARS CANADA or its authorized third party service provider if applicable, with the original sales receipt or other adequate written proof of the original purchase date and identification of the product. In the event that the original purchaser is unable to provide a company of the original sales receipt, SEARS CANADA Inc. reserves the right to determine in its sole discretion what other written proof of the original purchase date and identification of the product is acceptable.

