

REPAIR PARTS MANUAL
MODEL NO. 253790



HOW TO USE THIS MANUAL

This manual is designed to provide the customer with a means to identify the parts on his/her tractor when ordering repair parts. The illustrations may or may not represent the actual assemblies; therefore, it is not recommended to use this manual as a guide to assemble or disassemble the tractor. Some hardware and parts are drawn larger in order to more readily identify them.

Each tractor has its own model number.

The model number for your tractor can be found on the fender under the seat.

When ordering parts, always give the following information:

- Product - Lawn Tractor
- MODEL NUMBER - **253790**
- Part Number
- Part Description

TABLE OF CONTENTS

SCHEMATIC	3
ELECTRICAL.....	4-5
CHASSIS	6-7
DRIVE.....	8-9
ENGINE.....	10-11
STEERING	12
SEAT	13
MOWER DECK	14-15
MOWER LIFT.....	16
DECALS.....	17
TRANSAXLE BREAKDOWN	18-19
ENGINE BREAKDOWN.....	20-23
WARRANTY.....	BACK COVER

TRACTOR - - MODEL NUMBER 917.253790

SCHEMATIC

SCH11

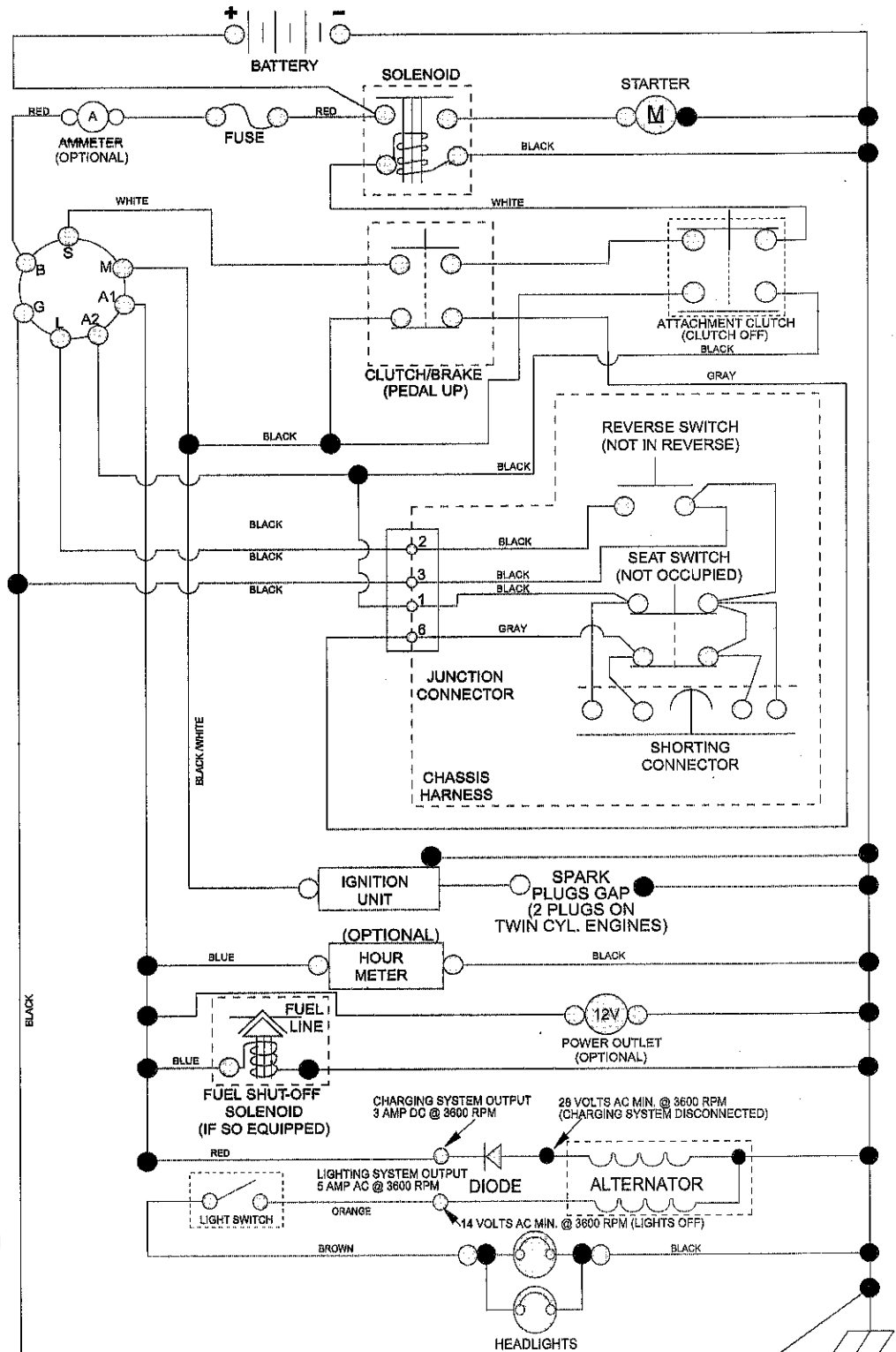

NOTE
YOUR TRACTOR IS EQUIPPED WITH A SPECIAL ALTERNATOR SYSTEM. THE LIGHTS ARE NOT CONNECTED TO THE BATTERY, BUT HAVE THEIR OWN ELECTRICAL SOURCE. BECAUSE OF THIS, THE BRIGHTNESS OF THE LIGHTS WILL CHANGE WITH ENGINE SPEED. AT IDLE THE LIGHTS WILL DIM. AS THE ENGINE IS SPEEDED UP, THE LIGHTS WILL BECOME THEIR BRIGHTEST.

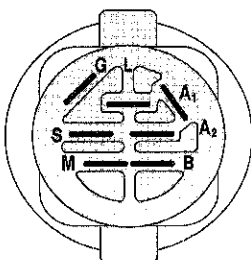

IGNITION SWITCH

POSITION	CIRCUIT	"MAKE"
OFF	M+G+A1	
RUN/OVERRIDE	B+A1	
RUN	B+A1	L+A2
START	B+S+A1	

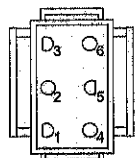

CHASSIS HARNESS CONNECTOR (MATING SIDE)

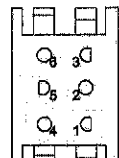

DASH HARNESS CONNECTOR (MATING SIDE)

WIRING INSULATED CLIPS
NOTE: IF WIRING INSULATED CLIPS WERE REMOVED FOR SERVICING OF UNIT, THEY SHOULD BE RE-INSTALLED TO PROPERLY SECURE YOUR WIRING.

NON-REMOVABLE CONNECTIONS

REMOVABLE CONNECTIONS

TRACTOR -- MODEL NUMBER 917.253790

ELECTRICAL

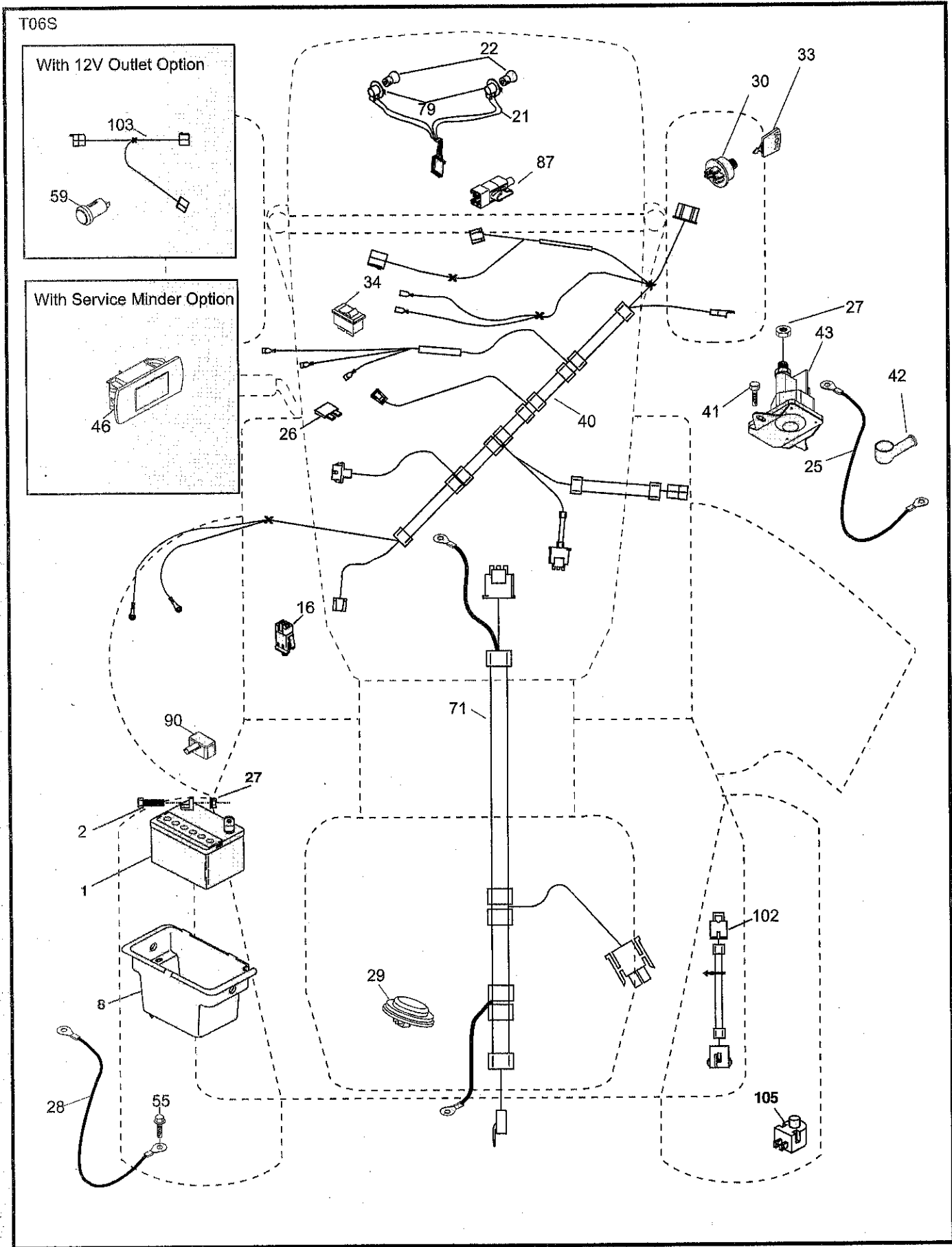

TRACTOR - - MODEL NUMBER 917.253790

ELECTRICAL

KEY NO.	PART NO.	DESCRIPTION
1	163465	Battery
2	74760412	Bolt Hex Hd 1/4-20 unc x 3/4
8	193228	Box Battery
16	176138	Switch Interlock Push-In
21	400252	Harness Socket Light w/4152J
22	4152J	Bulb Light
25	412894	Cable Starter
26	175158	Fuse
27	73510400	Nut Keps Hex 1/4-20 unc
28	198885	Cable, Ground
29	401545	Switch, Seat
30	193350	Switch, Ign
33	411934	Key/Chain
34	110712X	Switch Light / Reset
40	401098	Harness Ign. Dash
41	17720408	Screw Thd Cut 1/4-20 x 1/2
42	131563	Cover, Terminal
43	192507	Solenoid
55	17060512	Screw Thdrol 5/16-18 x 3/4 TYTT
71	400449	Harness Ign. Chassis
79	175242	Bulbholder Asm. Incan Descent
87	197802	Switch Interlock Clutch Cable
90	400725	Cover Terminal Battery
102	419781	Pigtail RER. GT. VATR
105	407568	Switch Reverse TT Pedal Control

NOTE: All component dimensions given in U.S. inches
1 inch = 25.4 mm

TRACTOR - - MODEL NUMBER 917.253790

CHASSIS ASSEMBLY

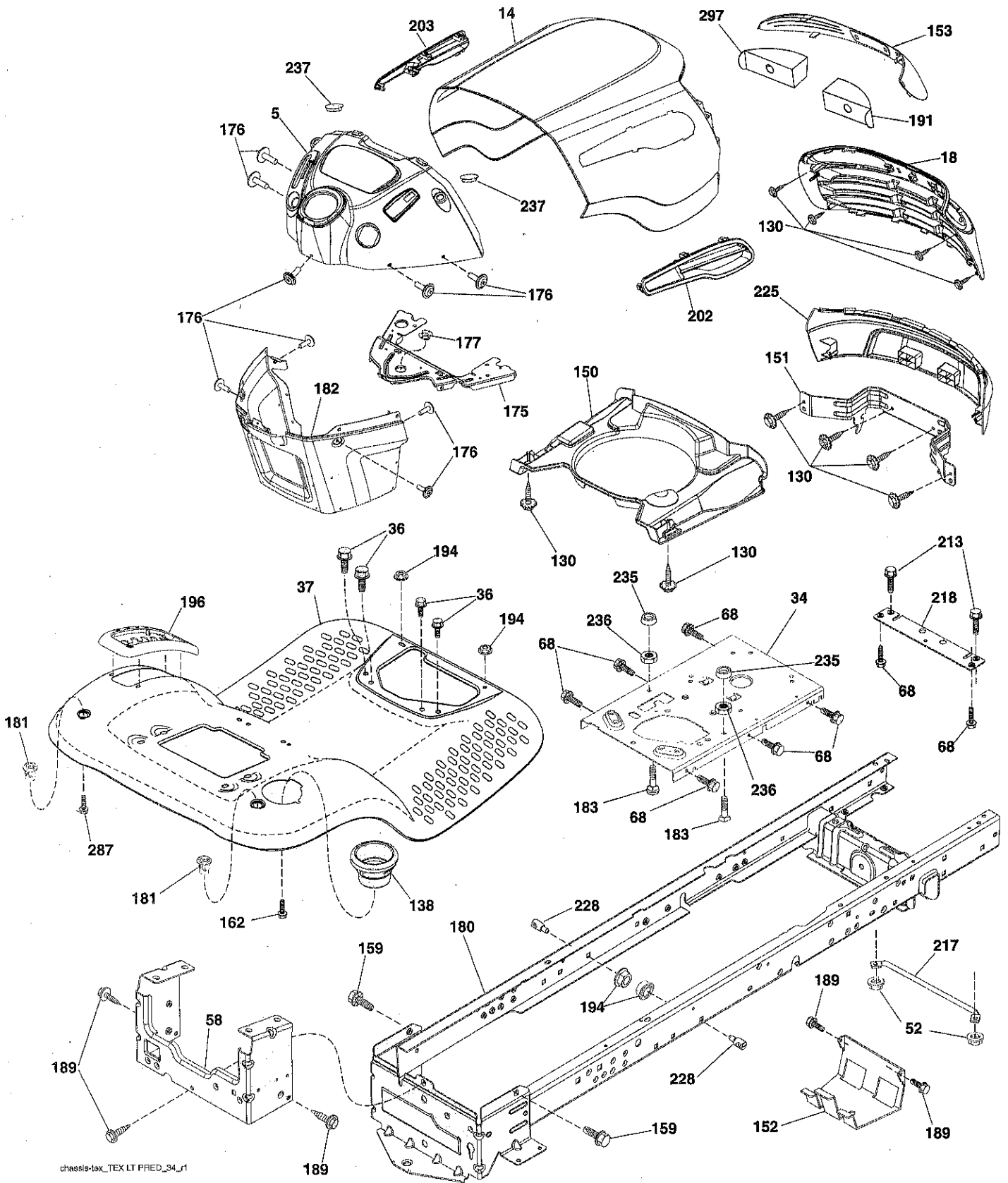

chassis-tox_TEX LT PRED_34_r1

TRACTOR -- MODEL NUMBER 917.253790

CHASSIS ASSEMBLY

KEY NO.	PART NO.	DESCRIPTION
5	408874X428	Dash
14	198416X613	Hood
18	423156	Grille
34	196125	Plate Engine
36	17060512	Screw 5/16-18 x 3/4
37	414872X613	Fender
52	73680500	Nut Crown Lock 5/16-18
58	412280	Drawbar Upper
68	17490508	Screw Thdrol 5/16-18 x 1/2
130	416358	Screw #10 x 0.750
138	193224X428	Cupholder
150	400267	Duct Heat Hood
151	187568	Bracket Pivot
152	199535	Shield Browning/Debris
153	400550X599	Lens
159	17000612	Screw Hexwsh Thdrol 3/8-16 x 3/4
162	142432	Screw Hex Wsh Hi-Lo 1/4 x 1/2
175	199472	Crossmember
176	400776	Screw 10-24 x 5/8 Wshd Qdrx
177	195228	Bushing Steering
180	415063	Chassis
181	193102X428	Bushing Mtg. Fender Crgo.
182	407176	Dash Lower
183	74780520	Bolt Fin Hex 5/16-18 x 1-1/4
189	17000512	Screw 5/16-18 x 3/4
191	416502	Insert Reflective RH
194	73900500	Nut Lock Hex Flange 5/16-18
196	414579	Console Asm. Deck Lift
202	423173	Vent Hood Side Panel RH
203	423172	Vent Hood Side Panel LH
213	74760512	Bolt Hex HD 5/16-18 unc x 3/4
217	409167	Rod Pivot Hood
218	196395	X-Piece Hoodstop
225	400549X613	Bumper
228	195161	Stud Fastener
235	406129	Spacer Fender
236	73930500	Nut Center Lock 5/16-18
237	403704	Plug Mount Cargo
287	17600406	Screw 1/4-20 x 3/8
297	401827	Insert Reflective LH

NOTE: All component dimensions given in U.S. inches
1 inch = 25.4 mm

TRACTOR -- MODEL NUMBER 917.253790

GROUND DRIVE

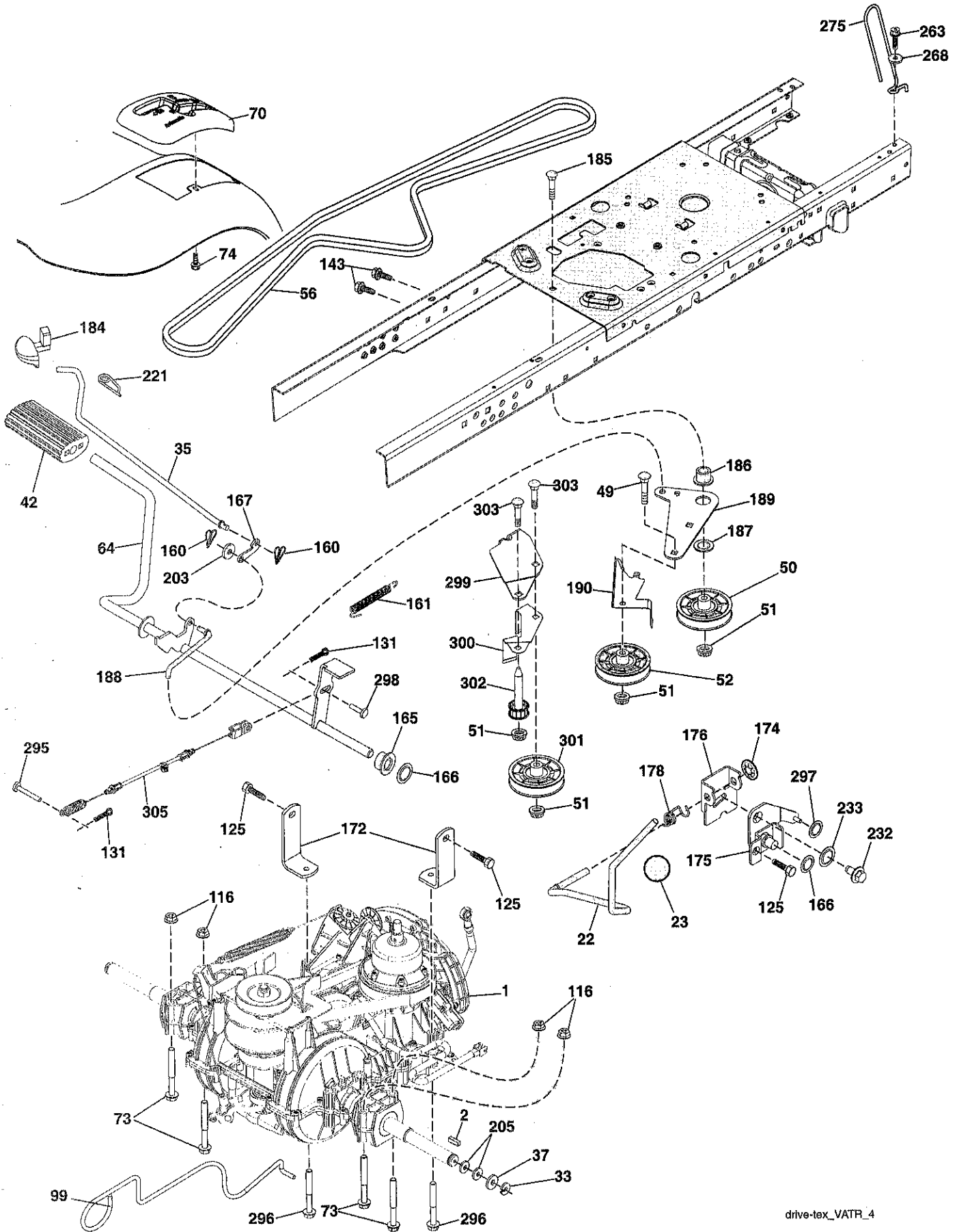

drive-lex_VATR_4

TRACTOR - - MODEL NUMBER 917.253790

GROUND DRIVE

KEY NO.	PART NO.	DESCRIPTION	KEY NO.	PART NO.	DESCRIPTION
1	415663	Transmission, Gentrans	178	197456	Spring Shift
2	123583X	Key Square	184	199996X505	Handle Parking Brake
22	421063	Rod Shift	185	72110622	Bolt
23	106933X	Knob	186	194321	Spacer Retainer
33	12000001	Ring E	187	19133210	Washer
35	401031	Rod, Brake, Park	188	194323	Link Clutch Ground Drive
37	121749X	Washer 25/32 x 1-1/4 x 16 Ga.	189	194317	Bellcrank Ground Drive
42	8883R	Cover, Foot Pedal	190	194318	Keeper Bellcrank Ground Drive
49	72110614	Bolt	203	19111116	Washer 11/32 x 11/16 x 16 Ga.
50	194327	Pulley Idler Flat	205	121748X	Washer 25/32 x 1-5/8 x 16 Ga.
51	73900600	Lock Nut 3/8-16	221	403187	Retainer Spring Clip Handle
52	194326	Idler V-Groove	232	74780716	Bolt 7/16-14 x 1 Gr. 5
56	197253	V-Belt, Drive	233	405296	Washer Serrated
64	196200	Shaft Asm. Pedal Brake Control	263	17000612	Screw 3/8-16 x 3/4
70	415688X428	Console	268	19131614	Washer 13/32 x 1 x 14 Ga.
73	74490544	Bolt 5/16-18 Gr. 5	275	182402	Guard Muffler
74	142432	Screw 1/4 x 1/2	295	420306	Pin Clevis 183 OD X 1.260 Long
99	427340	Rod Bypass	296	420471	Screw Thdrol 5/16-18 x 3
116	73900500	Nut Lock Hex Flange 5/16-18	297	420223	Nut Push 1/4
125	17000512	Screw 5/16-18 x 3/4	298	415694	Pin Clevis Cbl. Brk. Variator
131	76020312	Pin Cotter 3/32/ x 3/4	299	415683	Bracket Mount Idler
143	17490508	Screw Thdrol 5/16-18 x 1/2	300	415681	Keeper Idler Rear
160	169484	Retainer Clip	301	415680	Pulley Idler V-Groove
161	105709X	Spring, Return, Clutch	302	415666	Pulley Idler Flat 2.0 OD
165	196212	Busing Shaft Brake Hand Control	303	72110618	Bolt Rdhd Sgnk 3/8-16 x 2-1/4
166	197290	Nut Push .625	305	415692	Cable Brake Variator
167	405257	Latch Brake Parking			
172	415664	Strap Torque LH/RH			
174	197289	Nut Push			
175	415677	Shaft Asm Shift			
176	196214	Arm Clevis Rod Shift			

NOTE: All component dimensions given in U.S. inches
1 inch = 25.4 mm

TRACTOR - - MODEL NUMBER 917.253790

ENGINE

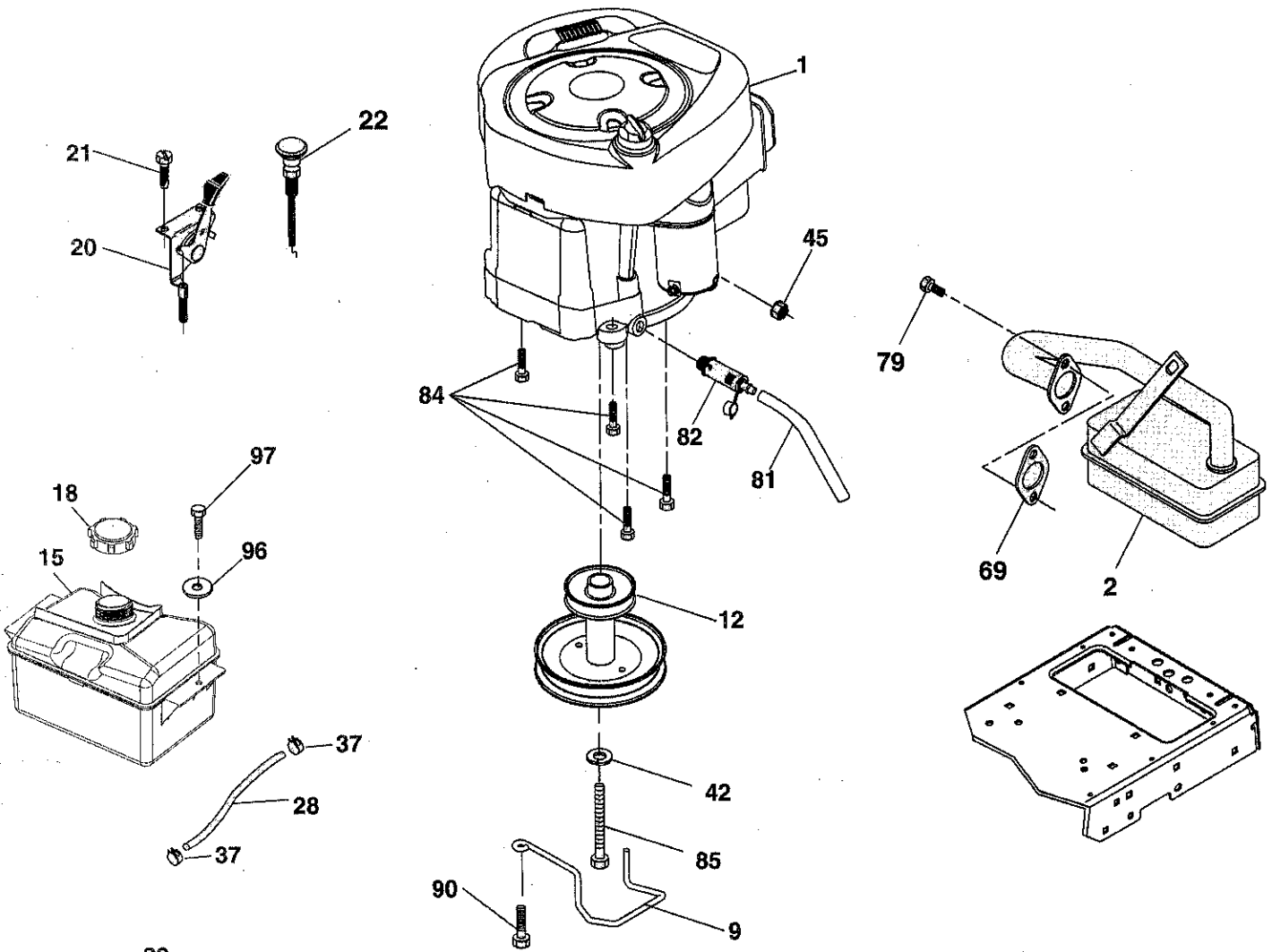

OPTIONAL EQUIPMENT
Spark Arrester

engine-tex_BS_5

TRACTOR - - MODEL NUMBER 917.253790

ENGINE

KEY NO.	PART NO.	DESCRIPTION
1	-----	Engine B&S Model No. 31P677-1319-B1
2	137352	Muffler
9	194319	Keeper Belt Engine
12	401985	Pulley Engine
15	407545	Tank Fuel 1.50
18	425162	Cap Fuel
20	176636X428	Control Throttle/Choke
21	416358	Screw #10 x 0.750
22	187771X428	Control Choke
28	137040	Fuel Line
29	137180	Spark Arrester Kit
37	123487X	Clamp Hose
42	10040700	Washer Lock 7/16
45	73510400	Nut Keps Hex 1/4-20 unc
69	165291	Gasket
79	192334	Screw Socket Hd 5/16-18 x .75
81	148456	Tube Drain Oil Easy
82	181654	Plug Drain Oil
84	17060620	Screw 3/8-16 x 1-1/4
85	173937	Bolt Hex 7/16-20 x 4 x Gr. 5-1.5
90	17000616	Screw 3/8-16 x 1.0
96	19091416	Washer 9/32 x 7/8 x 16 Ga.
97	17670412	Screw 1/4-20 x 3/4

NOTE: All component dimensions given in U.S. inches
1 inch = 25.4 mm

For engine service and replacement parts, call the toll free number for your engine manufacturer listed below:

Briggs & Stratton 1-800-233-3723

Engine Power Rating Information

The gross power rating for individual gas engine models is labeled in accordance with SAE (Society of Automotive Engineers) code J11940 (Small Engine Power & Torque Rating Procedure), and rating performance has been obtained and corrected in accordance with SAE J1995 (Revision 2002-5). Actual gross engine power will be lower and is affected by, among other things, ambient operating conditions and engine-to-engine variability. Given both the wide array of products on which engines are placed and the variety of environmental issues applicable to operating the equipment, the gas engine will not develop the rated gross power when used in a given piece of power equipment (actual "on-site" or net horsepower). This difference is due to a variety of factors including, but not limited to, accessories (air cleaner, exhaust, charging, cooling, carburetor, fuel pump, etc.), application limitations, ambient operating conditions (temperature, humidity, altitude), and engine-to-engine variability. Due to manufacturing and capacity limitations, Briggs & Stratton may substitute an engine of higher rated power for this Series engine.

TRACTOR - - MODEL NUMBER 917.253790

STEERING ASSEMBLY

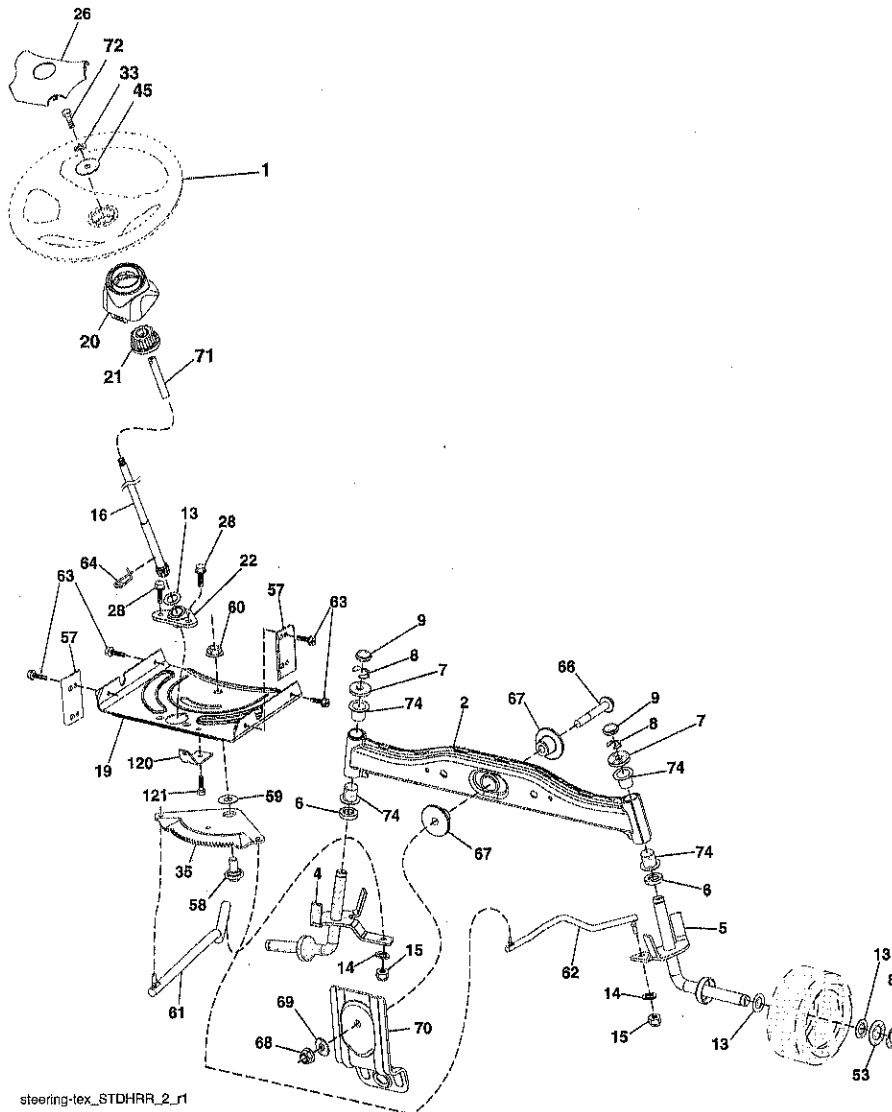

steering-tex_STDHRR_2_r1

KEY NO.	PART NO.	DESCRIPTION
1	414803X428	Wheel, Steering
2	418168	Axle Asm., Front
4	403087	Spindle Asm., LH
5	403088	Spindle Asm., RH
6	6266H	Washer Thrust 0.75 x 1.23
7	121748X	Washer 25/32 x 1-5/8 x 16 Ga.
8	12000029	Ring, Clip #T5304-75
9	121232X	Cap, Spindle
13	121749X	Washer 25/32 x 1-1/4 x 16 Ga.
14	10040600	Washer Lock 3/8
15	73540600	Nut, Crown Lock 3/8-24 unf
16	408220	Shaft Steering
19	194729	Plate Steering
20	400803X428	Boot, Steering
21	186737	Adapter, Wheel Steering
22	194845	Bushing, Strg. Blk
26	414852X428	Insert, Wheel Steering
28	17000612	Screw 3/8-16 x 3/4
33	10040500	Washer Lock 5/16
35	194732	Gear, Sector Plate
45	19113812	Washer 11/32 x 2-3/8 x 12 Ga.
53	188967	Washer Hardened .793 x 1.637 x .060

KEY NO.	PART NO.	DESCRIPTION
57	407465	Bracket Upstop
58	194747	Bolt Shoulder Sector Pivot CFM
59	194748	Washer Thrust Sector Steering
60	73971000	Nut Flange Lock 5/8-11
61	194740	Draglink, LH
62	194741	Draglink, RH
63	17000512	Screw 5/16-18 x 3/4
64	199849	Retainer Clip Spring Steering
66	71020748	Bolt Hex Fghd 7/16-14 x 3 Serr
67	194737	Bushing PM Front Axle
68	73900700	Nut Lock Flange 7/16-14 Gr. 5
69	199162	Washer 1.5 x .505 x .118
70	196197	Bracket Deck Susp. Front
71	196075	Shaft Ext. Steering
72	74780572	Bolt 5/16-18 x 4.5 Gr. 5
74	3366R	Bearing
120	415689	Brake Cable Locator Bracket
121	17490508	Screw 5/16-18 x 1/2

NOTE: All component dimensions give in U.S. inches
1 inch = 25.4 mm

TRACTOR -- MODEL NUMBER 917.253790

SEAT ASSEMBLY

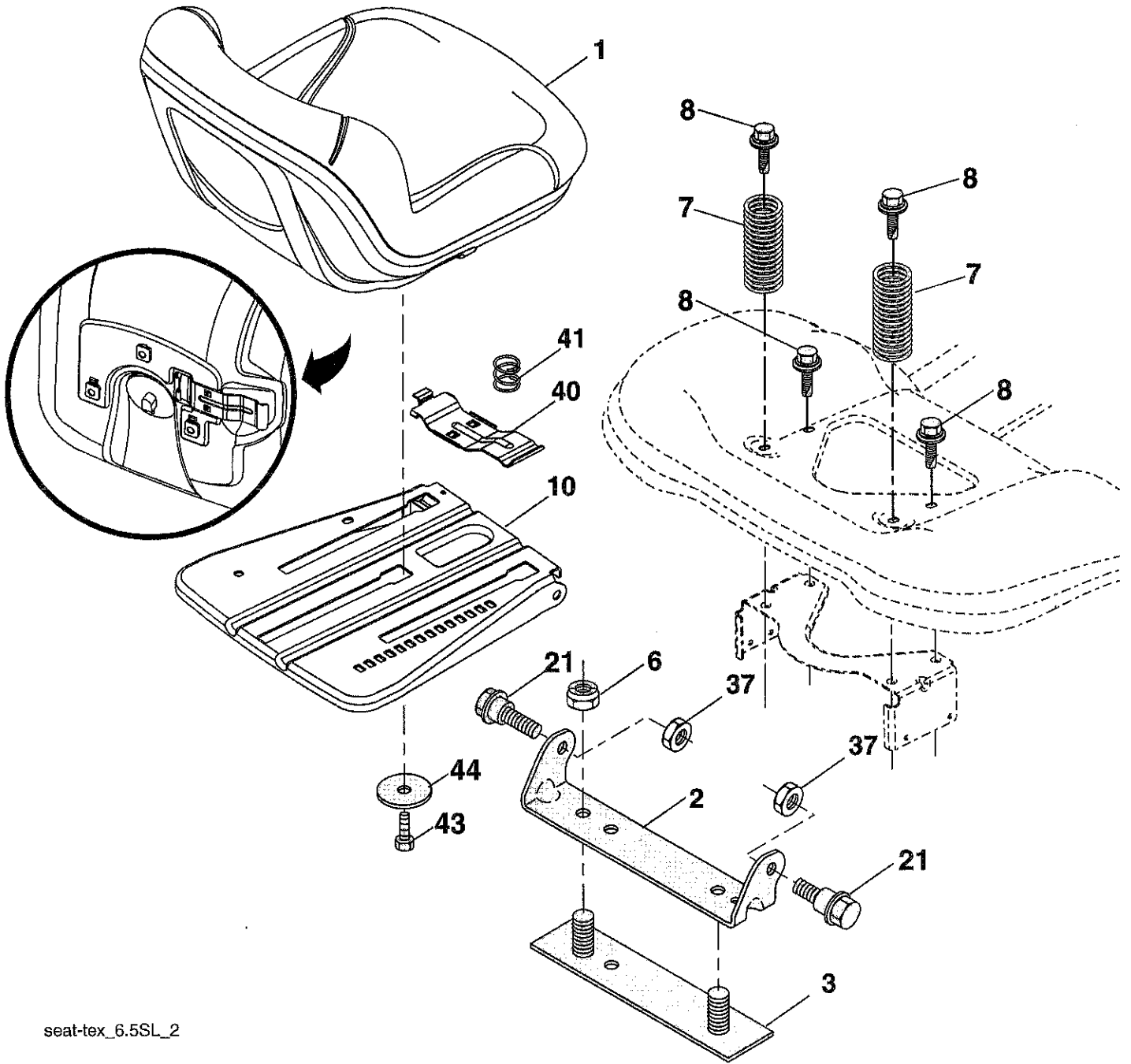

seat-tex_6.5SL_2

KEY NO.	PART NO.	DESCRIPTION
1	423644	Seat
2	180166	Bracket Pivot Fender
3	140675	Strap, Asm Fender
6	73800600	Nut, Lock w/Ins. 3/8-16 unc
7	124181X	Spring, Seat Cprsn
8	171877	Bolt 5/16-18 unc x 3/4 w/Sems
10	196977	Pan, Seat
21	171852	Bolt, Shoulder 5/16-18
37	73800500	Nut, Lock 5/16-18 unc

KEY NO.	PART NO.	DESCRIPTION
40	197661	Handle Slide
41	198200	Spring Latch
43	74760612	Bolt 3/8-16 unc x 3/4
44	19133812	Washer 13/32 x 2 3/8 x 12 Ga.

NOTE: All component dimensions give in U.S. inches
1 inch = 25.4 mm

TRACTOR -- MODEL NUMBER 917.253790

MOWER DECK

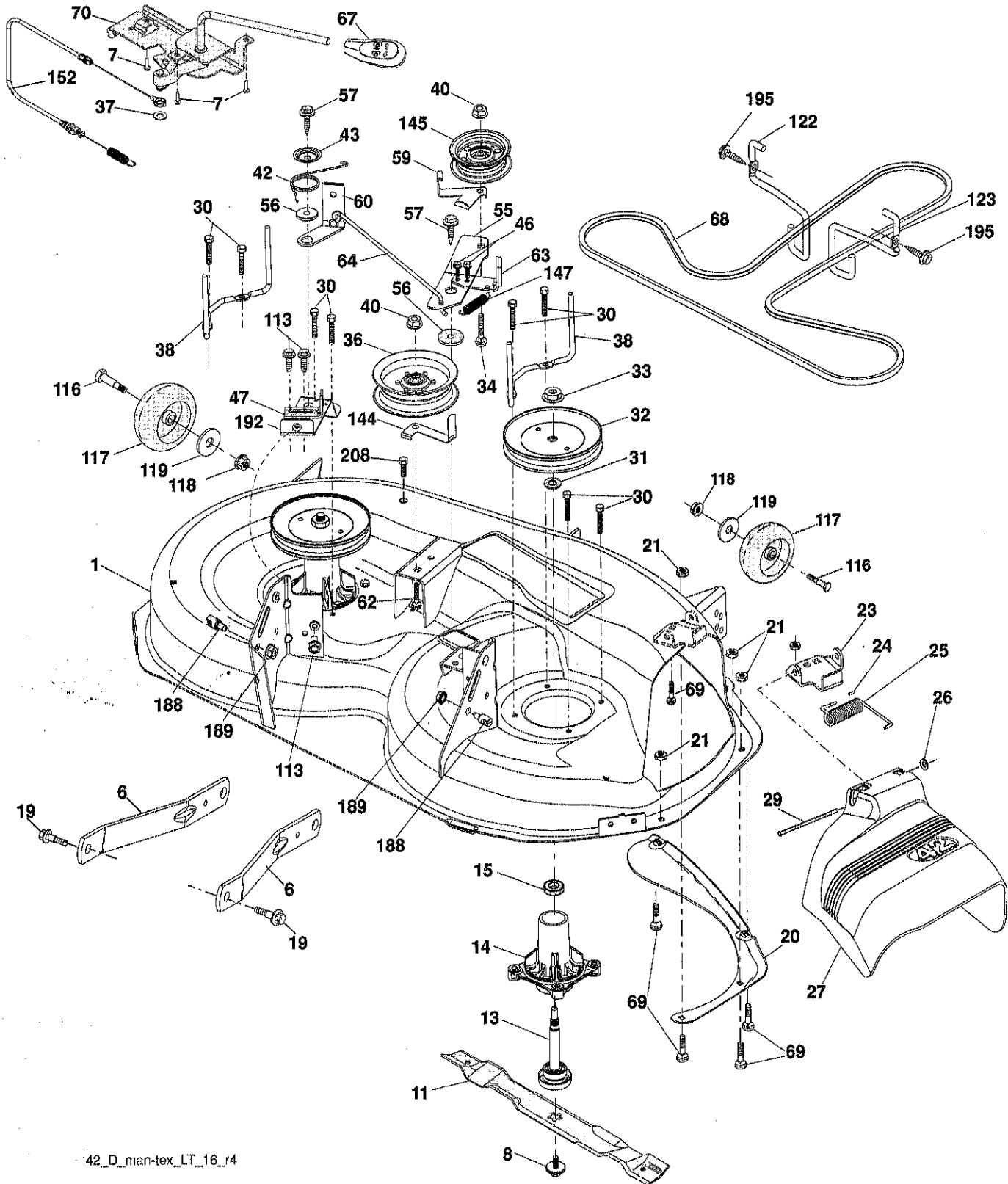

42_D_man-tex_LT_16_r4

TRACTOR -- MODEL NUMBER 917.253790

MOWER DECK

KEY NO.	PART NO.	DESCRIPTION	KEY NO.	PART NO.	DESCRIPTION
1	196495	Mower Housing	56	199092	Spacer, Retainer
6	195186	Arm Suspension	57	17000616	Screw Hexwsh Thd 3/8-16 x 1
7	416358	Screw 10 x .750 BOS Thread	59	141043	Guard, Tuv Idler (94)
8	193003	Bolt/Washer Asm 7/16-20 unf	60	197261	Arm Brake Mower
11	424752	Blade 3 in 1	62	72110616	Bolt Rdhd Sqnk 3/8-16 unc x 2
--	422719	Blade 3 in 1 Premium	63	199477	Arm Brake Mower
--	134149	Blade Mulching Standard	64	199790	Linkage Brake
--	139775	Blade Mulching Premium	67	198398X428	Handle, Clutch Cable
--	138971	Blade, 42" Hi-Lift (For bagging or discharge)	68	197253	V-Belt
13	192872	Shaft Assembly, Mandrel	69	72140505	Bolt Rdhd Sqnk 5/16-18 x 5/8
14	187281	Housing, Mandrel	70	401246	Clutch Asm. Manual
15	110485X	Bearing, Ball, Mandrel	113	17000510	Screw 5/16-18
19	196539	Bolt, Shoulder	116	4898H	Bolt Shld. "A" 2.41 "B"1.66
20	159770	Baffle, Vortex	117	188606	Wheel Gage
21	73680500	Nut, Crownlock 5/16-18 unc	118	73930600	Nut Centerlock 3/8-16 unc
23	192557	Bracket, Deflector	119	19121414	Washer 3/8 x 7/8 x 14 Ga.
24	105304X	Cap, Sleeve	122	197258	Keeper Belt Eng. LH
25	197026	Spring, Torsion, Deflector	123	197259	Keeper Belt Eng. RH
26	110452X	Nut, Push	144	199204	Keeper Belt
27	424469	Shield, Deflector	145	193197	Pulley, Idler, Flat
29	131491	Rod, Hinge	147	401971	Spring Return
30	173984	Screw Thdrol Rolling Wsh Hd	152	408714	Cable Clutch Manual w/Spr.
31	187690	Washer, Spacer	188	195161	Stud Fastener
32	197473	Pulley, Mandrel	189	73900500	Nut Lock Hex Flange
33	400234	Nut, Toplock, Flanged	192	197260	Bracket Brake Stand LH
34	72110612	Bolt Carr Sh. 3/8-16 x 1-1/2 Gr. 5	195	17000612	Screw Hexwsh Thdr 3/8-16 x 3/4
36	197379	Pulley Idler	208	17670608	Screw 3/8-16 x 1/2
37	19131316	Washer 13/32 x 13/16 x 16 Ga.	--	192870	Mandrel Assembly (Mandrel Assembly (Includes housing, shaft assembly, and bearing only-pulley/ nut/washer and blade bolt/washers not included)
38	199189	Keeper Belt LH Mandrel	--	425415	Replacement Mower, Complete
40	73900600	Nut, Lock Flg. 3/8-16 unc			
42	198410	Spring Torsion Brake			
43	197256	Spring Torsion Retainer			
46	137729	Screw Thd Roll 1/4-20 x 5/8			
47	197250	Bracket Clutch Cable			
55	197249	Arm, Idler			

NOTE: All component dimensions given in U.S. inches
1 inch = 25.4 mm

TRACTOR - - MODEL NUMBER 917.253790

LIFT ASSEMBLY

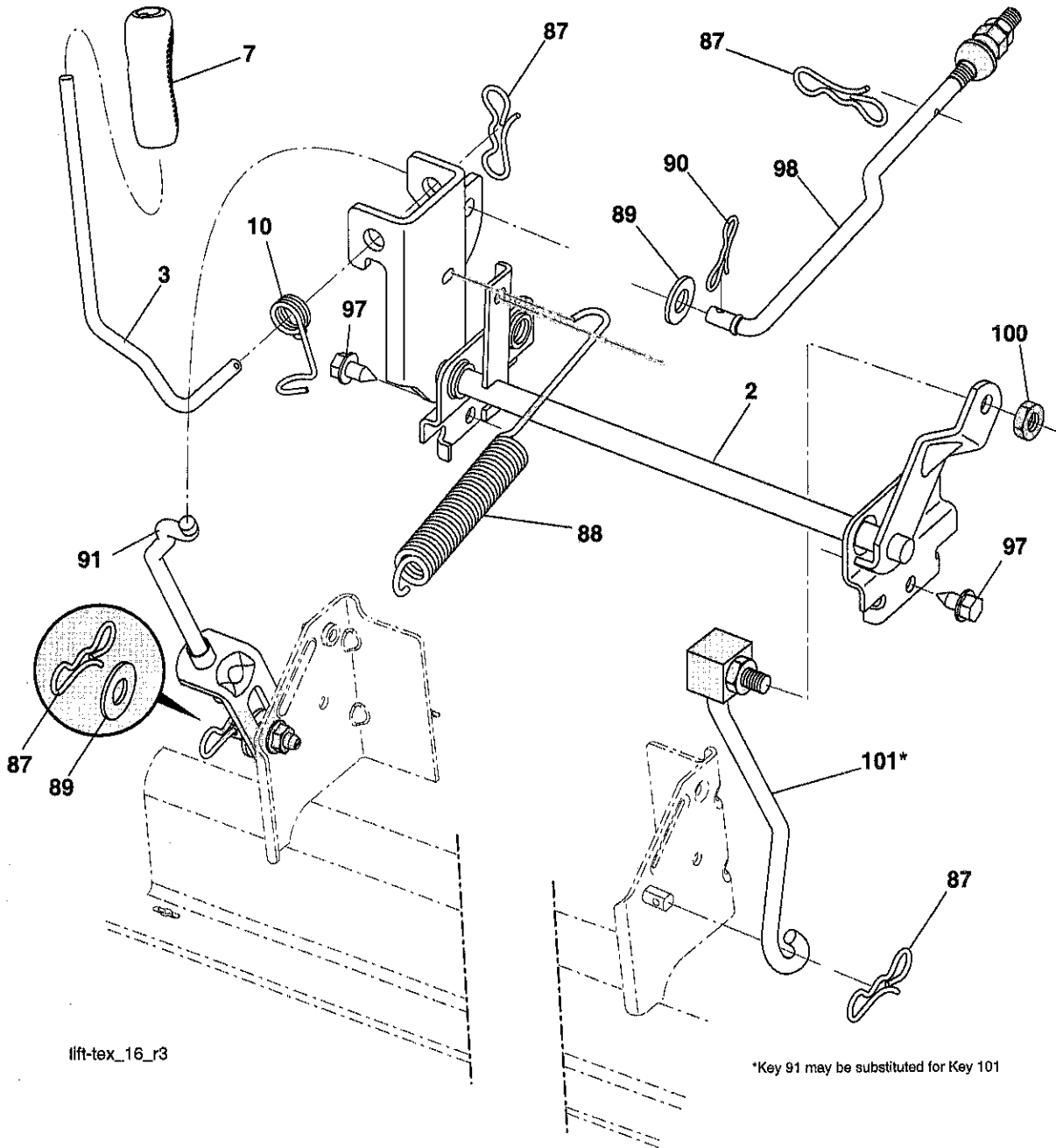

lift-tex_16_r3

*Key 91 may be substituted for Key 101

KEY NO.	PART NO.	DESCRIPTION
2	195223	Shaft Asm., Lift
3	195231	Lever Asm., Lift RH
7	196492X428	Grip, Lever
10	196314	Spring Torsion
87	194209	Pin Cotter 7/16 Bow Tie Lock
88	410710	Spring Lift Assist
89	19191912	Washer Clear Zinc
90	194208	Pin Cotter 5/16 Bow Tie Lock
91	195181	Link Lift Susp Mower Rear

KEY NO.	PART NO.	DESCRIPTION
97	17000612	Screw 3/8-16 x .75
98	195270	Link Lift Susp. Front Mower
100	73930600	Nut Centerlock 3/8-16 unc
101	407003	Link Asm Lift Fixed

NOTE: All component dimensions give in U.S. inches
1 inch = 25.4 mm

TRACTOR -- MODEL NUMBER 917.253790

DECALS

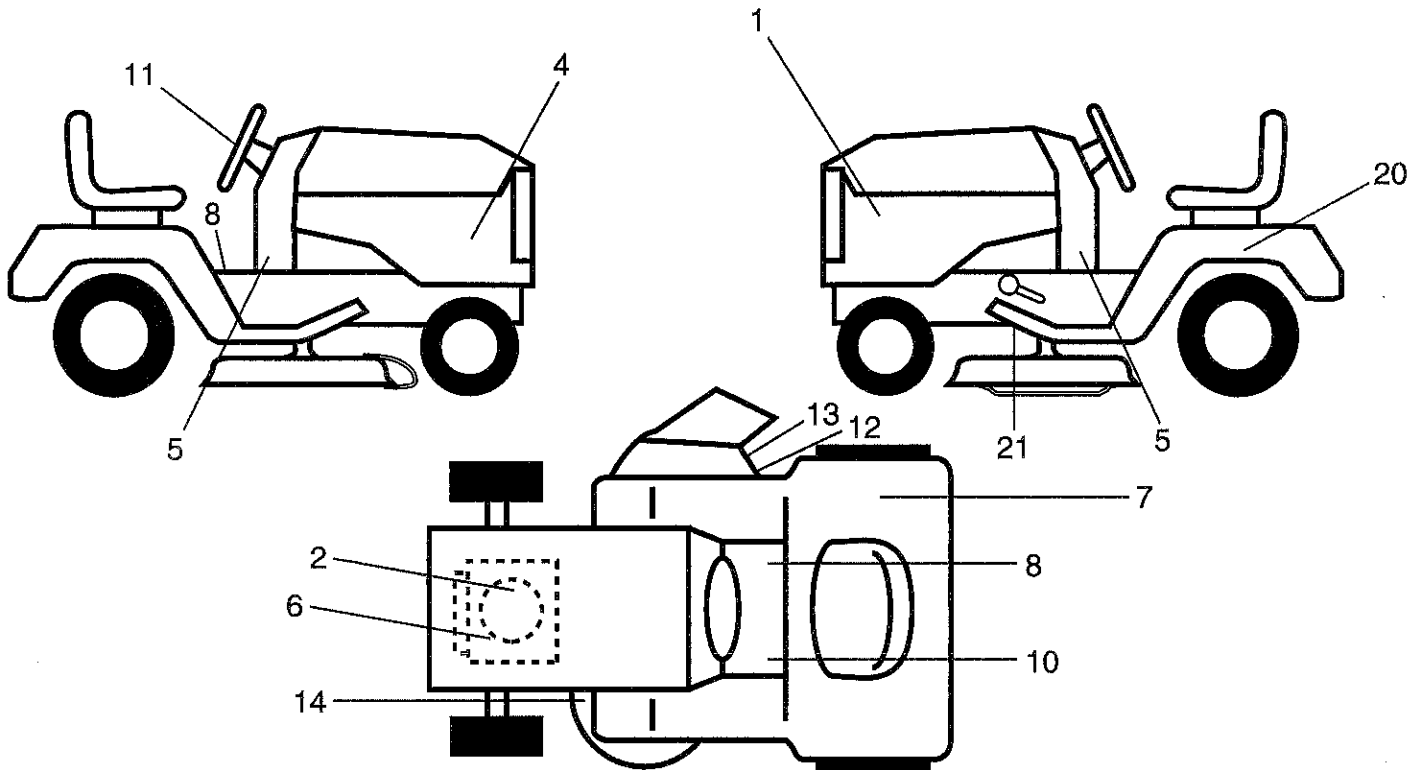

KEY NO.	PART NO.	DESCRIPTION
1	422865	Decal Side Panel Logo
2	418565	Decal Eng. H.P.
4	422863	Decal Side Panel Logo RH
5	425786	Decal Lwr Dash
6	196841	Decal Warning Engine
7	180432	Decal Fender DB/CE
8	400389	Decal Fender Warn
9	159736	Decal Hot Muffler
10	159737	Decal Brake/Clutch
11	422885	Decal Ins Strg Whl
12	196357	Decal Warning
13	182166	Decal Cutfinger CE

KEY NO.	PART NO.	DESCRIPTION
14	160396	Decal V-Belt Schematic
16	140837	Decal Saddle Brake Parking
20	145005	Decal Bat Dan/Psn
21	199135	Decal V-Belt Sch.
--	166960	Decal Bypass Fender
--	193226X428	Pad Footrest LH
--	193227X428	Pad Footrest RH
--	427187	Manual Oper. (Euro)
--	427188	Manual Oper. (Scan)
--	427189	Manual Oper. (E-Bloc)
--	427190	Manual Oper. (Baltic)
--	427191	Manual Parts (English)

WHEELS & TIRES

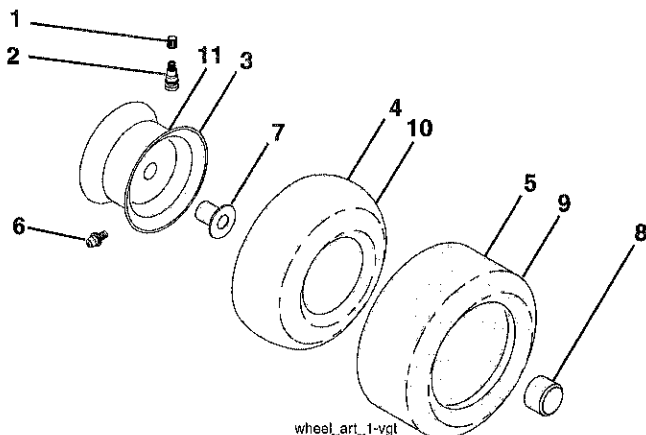

KEY NO.	PART NO.	DESCRIPTION
1	59192	Cap Valve Tire
2	65139	Stem Valve
3	106732X613	Rim Asm 6" Front
4	59904	Tube Front (Service Item Only)
5	106222X	Tire F T 15 x 6 0 - 6
6	278H	Fitting Grease (Front Wheel Only)
7	9040H	Bearing Flange (Front Wheel Only)
8	104757X428	Cap Axle Blk 1 50 x 1 00
9	420531	Tire R T 18 x 9.5-8C
10	7152J	Tube Rear (Service Item Only)
11	106108X613	Rim Asm 8" Rear Service
--	144334	Sealant, Tire (10 oz. Tube)

NOTE: All component dimensions give in U.S. inches
1 inch = 25.4 mm

TRACTOR -- MODEL NUMBER 917.253790

GENTRANS TRANSAXLE

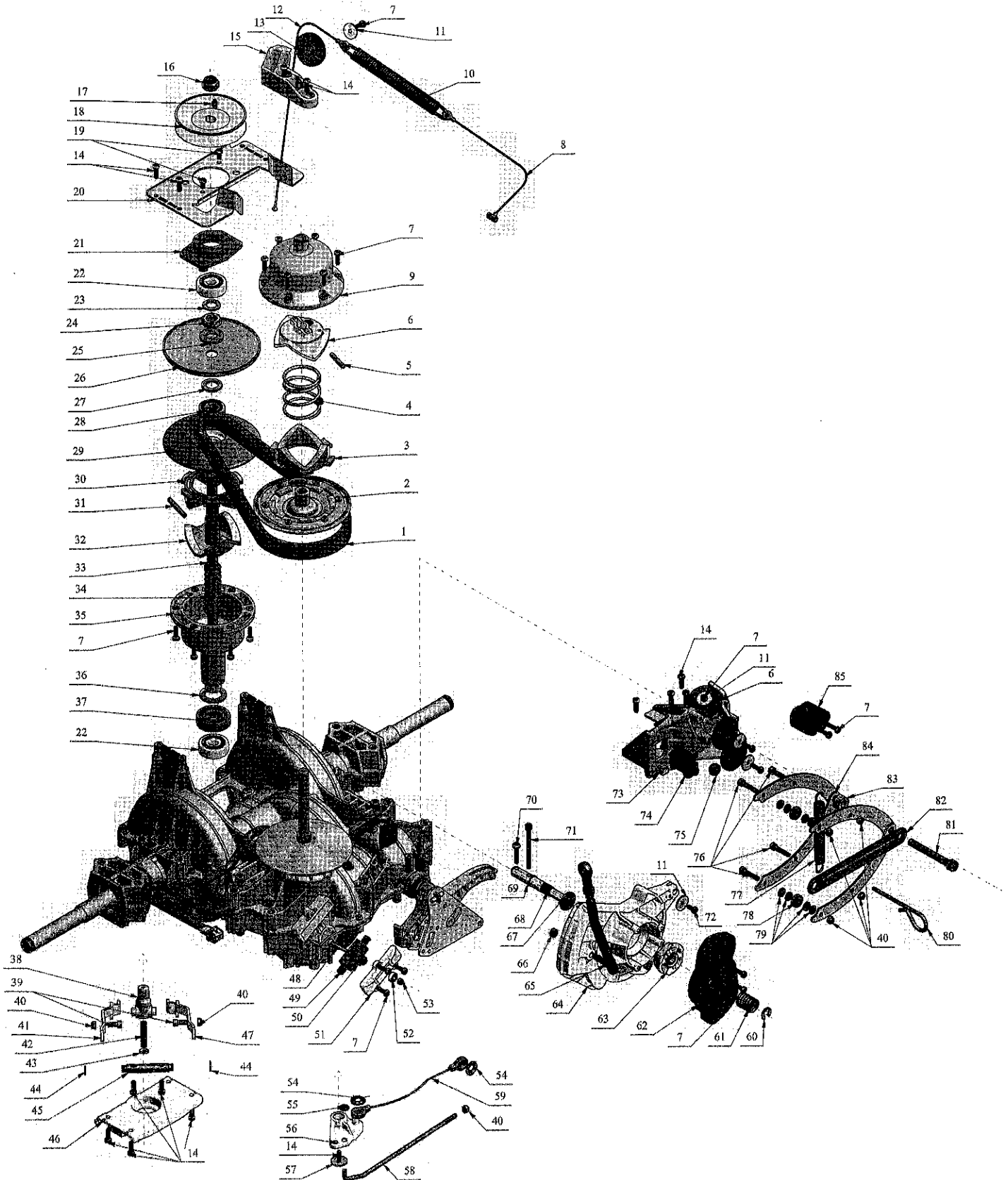

TRACTOR - - MODEL NUMBER 917.253790

GENTRANS TRANSAXLE

KEY NO.	PART NO.	DESCRIPTION	KEY NO.	PART NO.	DESCRIPTION
1	426740	Belt	46	426788	Inferior plate
2	426739	Flange	47	426787	Lever
3	426738	Ramp	48	426786	Screw M4 (0.7Nm)
4	426737	Spring	49	426785	Spring
5	426736	Pin	50	426784	Inversion axle
6	426735	Fixed ramp	51	426783	Cover
7	426734	Screw 4x16 (torque 2.2Nm)	52	426782	Ball bearing 604.2RS
8	426733	Cable	53	426781	Nut M4
9	426732	Cap	54	426780	Starlock Ø8
10	426731	Spring	55	426779	Starlock Ø4
11	426730	Washer	56	426778	Lever
12	426729	Cable	57	426777	Washer 5x20x1
13	426728	Cable sheave	58	426776	Rod
14	426727	Screw 5x16 (torque 2.2Nm)	59	426775	Cable
15	426726	Support 1 sheave	60	426774	Clip
16	426725	Nut M12	61	426773	Spring
17	426724	Key 4x6.5	62	426772	Cam
18	426723	Pulley	63	426771	Cone
19	426722	Screw 5x10 (torque 2.2Nm)	64	426770	Cam
20	426721	Superior plate	65	426769	Rod
21	426720	Bushing	66	426768	Nut 1/4" (5Nm)
22	426710	Ball bearing 6301.2RS	67	426767	Washer 13x24x2,5
23	426709	Washer 13x22x1.5	68	426766	Axle
24	426708	Scerw M14x1.5	69	426765	Clip 12x1
25	426707	Washer 15.1x29.5x3	70	426763	Screw 5x25 (Torque 3.3Nm)
26	426706	Flange Ø15.1	71	426764	Screw M5x60 (Torque 3.3Nm)
27	426704	Washer 15.7x25.3x2	72	426762	Screw 4x10 (Torque 2.2Nm)
28	426703	Ball bearing 6002.2RS	73	426761	Support
29	426702	Flange Ø17.7	74	426758	Switch
30	426701	Mobile ramp 40°	75	426756	Nut M8
31	426700	Pin 5x40	76	426755	Screw M5x25 (Torque 2.2Nm)
32	426699	Fixed ramp 40°	77	426754	Spring
33	426698	Variator shaft	78	426753	Ball bearing 625 2RS
34	426697	Variator Spring	79	426752	Washer 5.3x10x1.7
35	426696	Cap	80	426751	Pin Ø4
36	426693	Washer 21x33x1.5	81	426750	Screw M8x70 (1.1m)
37	426692	Ball bearing 6004 2RS	82	426749	Plate
38	426691	Cable hook	83	426748	Spacer
39	426690	Screw M5x12	84	426747	Jaws
40	426689	Nut M5	85	426746	Snap-in
41	426687	Lever			
42	426686	Spring			
43	426791	Washer 3x11.7x2			
44	426790	Clips 8x0.8			
45	426789	Axle			

NOTE: All component dimensions give in U.S. inches
1 inch = 25.4 mm

TRACTOR - - MODEL NUMBER 917.253790

BRIGGS & STRATTON ENGINE-MODEL NUMBER 31P677, TYPE NUMBER 1319-B1

48 SHORT BLOCK

1036 EMISSIONS LABEL

1058 OPERATOR'S MANUAL

1329 REPLACEMENT ENGINE

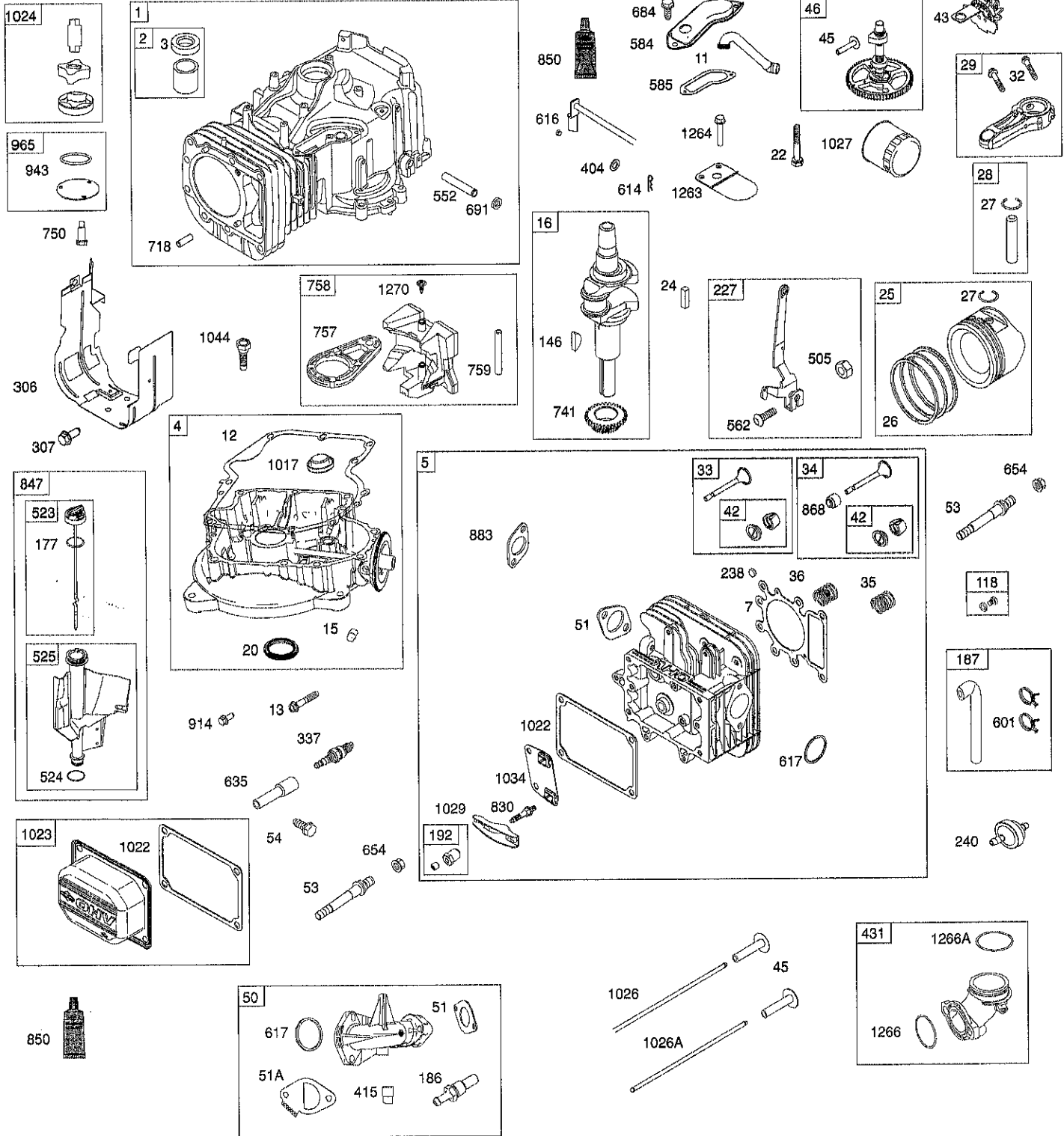

TRACTOR - - MODEL NUMBER 917.253790

BRIGGS & STRATTON ENGINE-MODEL NUMBER 31P677, TYPE NUMBER 1319-B1

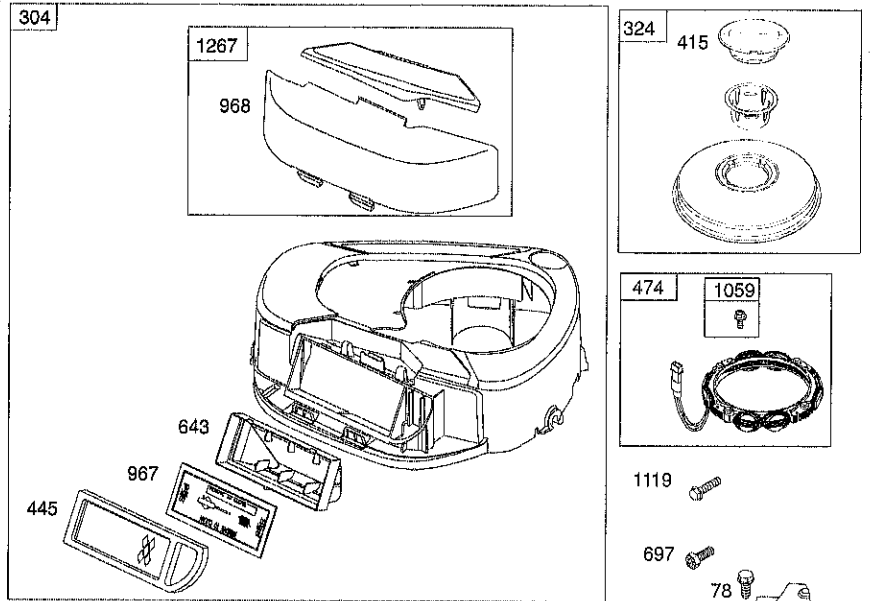
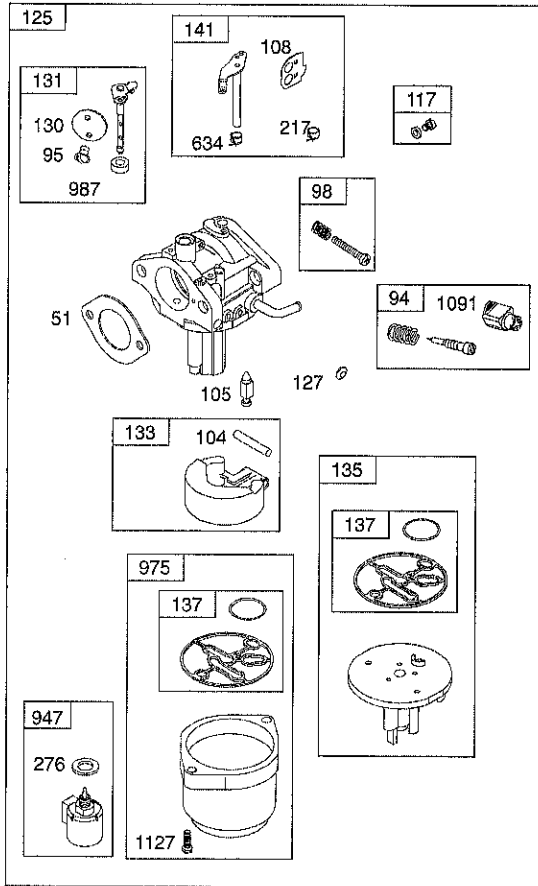

1036 EMISSIONS LABEL

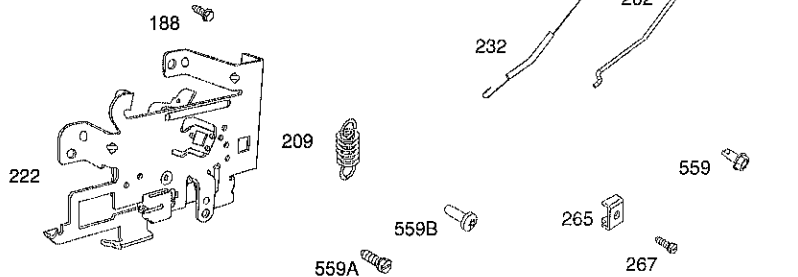
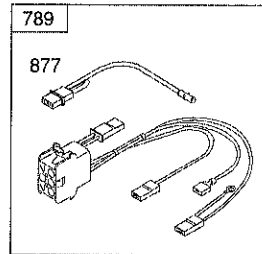
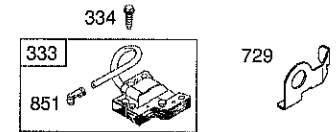
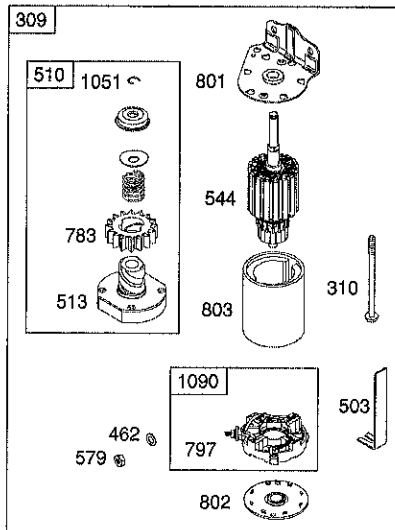
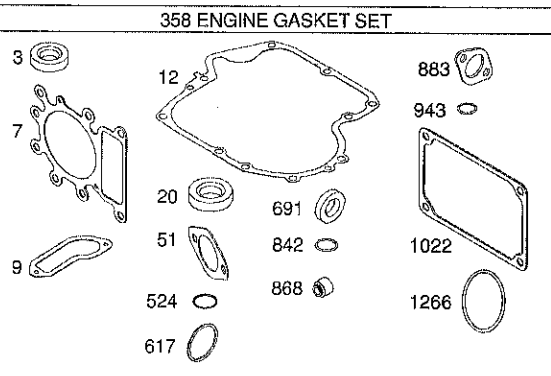
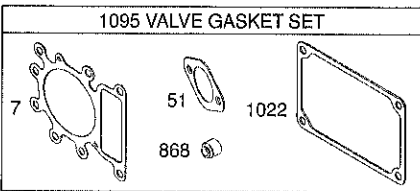
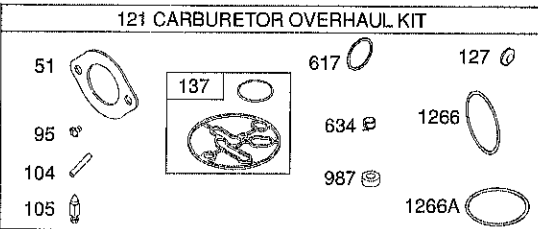
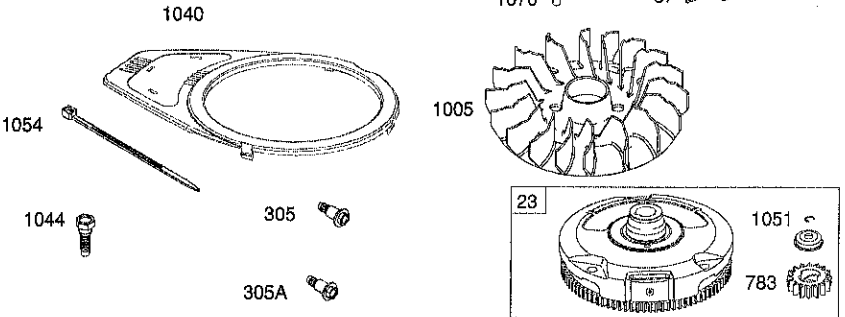

TRACTOR -- MODEL NUMBER 917.253790

BRIGGS & STRATTON ENGINE-MODEL NUMBER 31P677, TYPE NUMBER 1319-B1

KEY NO.	PART NO.	DESCRIPTION	KEY NO.	PART NO.	DESCRIPTION
1	796010	Cylinder Assembly	130	792747	Valve-Throttle
2	399265	Kit-Bushing/Seal (Magneto Side)	131	792765	Kit-Throttle Shaft
3	391086s •	Seal-Oil (Magneto Side)	133	694914	Float-Carburetor
4	795993	Sump-Engine	135	698780	Tube-Fuel Transfer
5	796005	Head-Cylinder	137	698781	Ø Gasket-Float Bowl
7	794114 •+	Gasket-Cylinder Head	141	792777	Kit-Choke Shaft
11	794683	Tube-Breather	146	691639	Key-Timing
12	697110 •	Gasket-Crankcase	177	691031	Seal-O Ring (Dipstick)
13	793988	Screw (Cylinder Head)	186	794873	Connector-Hose (Intake Manifold)
15	690946	Plug-Oil Drain	187	791805	Line-Fuel (Formed) (Cut to Required Length)
16	793410	Crankshaft			
20	795387 •	Seal-Oil (PTO Side)	188	691693	Screw (Control Bracket)
22	692125	Screw (Crankcase Cover/Sump)	192	691986	Adjuster-Rocker Arm
23	693557	Flywheel	202	691841	Link-Mechanical Governor
24	222698s	Key-Flywheel	209	692208	Spring-Governor (Green)
25	796172	Piston Assembly (Standard)	217	695409	Spring-Choke Return
	793019	Piston Assembly (.020" Oversize)	222	694042	Bracket-Control
26	796173	Ring Set (Standard)	227	691374	Lever-Governor Control
	792649	Ring Set (.020" Oversize)	232	691842	Spring-Governor Link
27	698469	Lock-Piston Pin	238	691843	Cap-Valve
28	796007	Pin-Piston	240	394358s	Filter-Fuel
29	794571	Rod-Connecting (Standard)	265	691024	Clamp-Casing
32	791118	Screw (Connecting Rod)	267	794904	Screw (Casing Clamp)
33	792868	Valve-Exhaust	276	695410	Ø Washer-Sealing
34	791935	Valve-Intake	304	796416	Housing-Blower
35	691279	Spring-Valve (Intake)	305	697102	Screw (Blower Housing) (Long)
36	691279	Spring-Valve (Exhaust)	305A	793376	Screw (Blower Housing) (Short)
37	697352	Guard-Flywheel	306	796006	Shield-Cylinder
42	499586	Retainer-Valve	307	691003	Screw (Cylinder Shield)
43	691968	Slinger-Governor/Oil	309	693551	Motor-Starter
45	690564	Tappet-Valve	310	690323	Bolt (Starter Motor)
46	793880	Camshaft	324	796308	Screen/Cup Assembly
48	697762	Short Block	333	795315	Armature-Magneto
50	796180	Manifold-Intake	334	691061	Screw (Magneto Armature)
51	692137 •Ø+	Gasket-Intake	337	691043	Plug-Spark
51A	796081	Gasket-Intake	358	794150	Gasket Set-Engine
53	690227	Stud (Carburetor)	404	691691	Washer (Governor Crank)
54	691148	Screw (Intake Manifold)	415	794129	Plug (Cover/Retainer)
78	691003	Screw (Flywheel Guard)	415A	690283	Plug (Intake Manifold)
94	793610	Kit-Idle Mixture	431	697122	Elbow-Intake
95	690718	Ø Screw (Throttle Valve)	445	795115	Filter-Air Cleaner Cartridge
98	695408	Kit-Idle Speed	462	691261	Washer (Starter Cable)
104	694918	Ø Pin-Float Hinge	474	696459	Alternator
105	696136	Ø Valve-Float Needle	503	691532	Strap-Starter
108	695419	Valve-Choke	505	691251	Nut (Governor Control Lever)
117	699773	Jet-Main (Standard)	510	693699	Drive-Starter
118	843099	Jet-Main (High Altitude)	513	692024	Clutch-Drive
121	796184	Kit-Carburetor Overhaul	523	699908	Dipstick
125	796152	Carburetor	524	691032	• Seal-Dipstick Tube
127	690727	Ø Plug-Welch	525	697184	Tube-Dipstick

TRACTOR -- MODEL NUMBER 917.253790

BRIGGS & STRATTON ENGINE-MODEL NUMBER 31P677, TYPE NUMBER 1319-B1

KEY NO.	PART NO.	DESCRIPTION	KEY NO.	PART NO.	DESCRIPTION
544		Starter-Armature (Not serviced separately, Order Starter Motor 693551, Reference 309)	947	699915	Solenoid-Fuel
552	697144	Bushing-Governor Crank	965	499613	Cover-Oil Pump
559	697561	Screw (Remote Choke) (Control Bracket)	967	697015	Filter-Pre Cleaner
559A	693675	Screw (Remote Choke) (Control Bracket)	968	698403	Cover-Air Cleaner
559B	699891	Screw (Speed Limiter) (Control Bracket)	975	699502	Bowl-Float
562	691119	Bolt (Governor Control Lever)	987	698777	Ø Seal-Throttle Shaft
579	691029	Nut (Starter Cable)	1005	796083	Fan-Flywheel
584	794682	Cover-Breather Passage	1017	796981	Screen-Oil Pump
585	697109	Gasket-Breather Passage	1022	272475s	Gasket-Rocker Cover (Rocker Cover Gasket and Liquid Sealant are interchangeable)
601	791850	Clamp-Hose (Green)	1023	791079	Cover-Rocker Arm
614	691620	Pin-Cotter (Governor Crank)	1024	794644	Pump-Oil
616	692012	Crank-Governor	1026	692003	Rod-Push (Intake)
617	692138	Ø • Seal-O Ring (Intake Manifold) (Red)	1026A	692011	Rod-Push (Exhaust)
634	698779	Ø Spring/Seal Assembly	1027	795890	Filter-Oil
635	691909	Boot-Spark Plug	1029	691751	Arm-Rocker
643	698401	Retainer-Air Filter	1034	690822	Guide-Push Rod
654	690958	Nut (Carburetor)	1036		Label-Emissions (Available from a BriggsandStrattonAuthorizedDealer)
684	697157	Screw (Breather Passage Cover)	1040	699852	Plate-Trim
691	692407	• Seal-Governor Shaft	1044	698139	Screw (Flywheel)
697	690372	Screw (Drive Cap)	1051	691265	Ring-Retaining
718	690959	Pin-Locating	1054	280275	Tie-Cable
729	691224	Clip-Wire	1058	275935	Owner's Manual
741	697128	Gear-Timing	1059	698516	Kit-Screw/Washer
750	790832	Screw (Oil Pump Cover)	1070	690363	Screw (Flywheel Fan)
757	793242	Link-Counterweight	1090	691293	Retainer-Brush
758	793763	Counterweight	1091	691333	Cap-Limiter
759	697392	Pin-Counterweight	1095	794152	Gasket Set-Valve
783	693713	Gear-Pinion	1119	691183	Screw (Alternator)
789	698329	Harness-Wiring	1127	695407	Screw (Float Bowl)
797	693167	Nut (Brush Retainer)	1263	697124	Reed-Breather
801	691283	Cap-Drive	1264	697104	Screw (Breather Reed)
802	691286	Cap-End	1266	691917	•Ø Seal-O Ring (Intake Elbow) (Red)
803		Housing-Starter (Not serviced separately, Order Starter Motor 693551, Reference 309)	1266A	697123	Ø Seal-O Ring(Intake Elbow)
830	691095	Stud (Rocker Arm)	1267	697419	Latch-Blower Housing
847	790442	Dipstick/Tube Assembly	1270	793243	Plug-AVS Counterweight
850	100106	Sealant-Liquid (Use to seal Breather Passage Cover or Rocker Cover)	1329	331877	Replacement Engine
851	692424	Terminal-Spark Plug		-0036-G1	
868	690968	•+ Seal-Valve			• Included in Engine Gasket Set, Key. No. 358
877	790544	Wire/Connector-Alternator			Ø Included in Carburetor Overhaul Kit, Key. No. 121
883	692236	Gasket-Exhaust			+ Included in Valve Gasket Set, Key. No. 1095
914	697551	Screw (Rocker Cover)			
943	690589	• Seal-O Ring (Oil Pump Cover)			

NOTE: All component dimensions given in U.S. inches.
1 inch = 25.4 mm

LIMITED WARRANTY ON CRAFTSMAN RIDING EQUIPMENT

For two (2) years from the date of purchase, if this Craftsman Riding Equipment is maintained, lubricated and tuned up according to the instructions in the owner's manual, Sears will repair or replace free of charge any parts that are found to be defective in material or workmanship according to the guidelines of coverage listed below. Sears will also provide free labor for these applicable warranted parts for the two full years. During the first 30 days of purchase, there will be no charges to service the product at your home for issues covered by this warranty. (See exclusions below). For your convenience, IN HOME warranty service will still be available after the first 30 days of purchase, but a trip charge will apply. This charge will be waived if the Craftsman product is dropped off at an authorized Sears location. For the nearest authorized Sears location, please call 1-800-4-MY-HOME®. This warranty applies only while this product is within the United States.

This Warranty does not cover:

- Expendable items which become worn during normal use, including but not limited to blades, spark plugs, air cleaners, belts, and oil filters.
- Standard Maintenance Servicing, oil changes, or tune-ups
- Tire replacement or repair caused by punctures from outside objects, such as nails, thorns, stumps, or glass.
- Repairs necessary because of operator abuse, including but not limited to, damage caused by towing objects beyond the capability of the riding equipment, impacting objects that bend the frame or crankshaft, or over-speeding the engine.
- Repairs necessary because of operator negligence, including but not limited to, electrical and mechanical damage caused by improper storage, failure to use the proper grade and amount of engine oil, failure to keep the deck clear of flammable debris, or failure to maintain the equipment according to the instructions contained in the owner's manual.
- Engine (fuel system) cleaning or repairs caused by fuel determined to be contaminated or oxidized (stale). In general, fuel should be used within 30 days of its purchase date.
- Normal deterioration and wear of the exterior finishes, or product label replacement.
- Riding equipment used for commercial or rental purposes.

LIMITED WARRANTY ON BATTERY

For ninety (90) days from date of purchase, if any battery included with this riding equipment proves defective in material or workmanship and our testing determines the battery will not hold a charge, Sears will replace the battery at no charge. During the first 30 days of purchase, there will be no charges to replace the battery at your HOME. After the first 30 days, for your convenience, IN-HOME warranty service will still be available but a trip charge will apply. This charge will be waived if the Craftsman product is dropped off at an authorized Sears location. For the nearest authorized Sears location, please call 1-800-4-MY-HOME®.

This battery warranty applies only while this product is within the United States.

This warranty gives you specific legal rights, and you may also have other rights, which vary, from state to state.

Sears, Roebuck and Co., Hoffman Estates, IL 60179

