

**SEARS**  
OWNER'S  
MANUAL

MODEL NO.  
917.254520

**Caution:**  
Read and follow  
all Safety Rules  
and Instructions  
Before Operating  
This Equipment

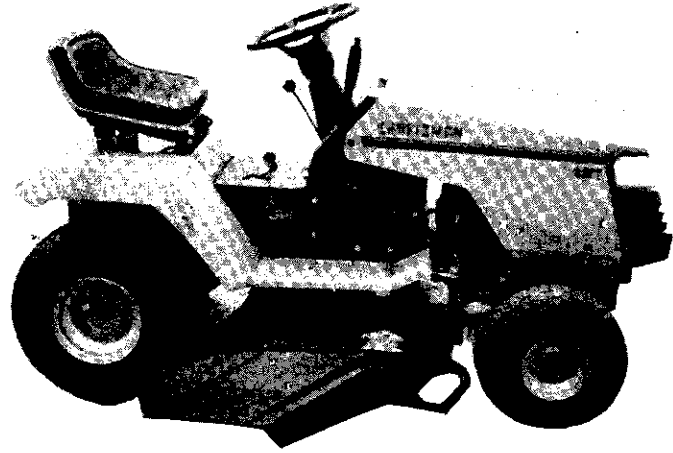

**CRAFTSMAN®**  
**12.0 HP IC**  
**ELECTRIC START**  
**38" MOWER DECK**  
**5 SPEED TRANSAXLE**  
**LAWN TRACTOR**

- Assembly
- Operation
- Maintenance
- Service and Adjustment
- Repair Parts



**LOOK FOR THIS SYMBOL TO POINT OUT IMPORTANT SAFETY PRECAUTIONS. IT MEANS - ATTENTION! BECOME ALERT! YOUR SAFETY IS INVOLVED.**

**CAUTION: LOOK FOR THIS WORD TO POINT OUT IMPORTANT EQUIPMENT PRECAUTIONS.**

**NOTE: LOOK FOR THIS WORD TO POINT OUT IMPORTANT INFORMATION ABOUT THE OPERATION AND PERFORMANCE OF YOUR TRACTOR.**



## **RULES FOR SAFE OPERATION**

**WARNING:** This unit is equipped with an internal combustion engine and should not be used on or near any unimproved forest covered, brush covered or grass covered land unless the engine's exhaust system is equipped with a spark arrester meeting applicable local or area laws (if any). If a spark arrester is used, it should be maintained in effective working order by the operator. (See REPAIR PARTS for part number identification).

In the State of California the above is required by law (Section 4442 of the California Public Resources Code). Other States may have similar laws. Federal laws apply on federal lands.

1. Know the controls and how to stop quickly. READ THIS OWNER'S MANUAL and instructions furnished with attachments.
2. Do not allow children to operate the machine. Do not allow adults to operate it without proper instruction.
3. Do not carry passengers. Do not mow when children and others are around.
4. Always wear substantial footwear. Do not wear loose fitting clothing that could get caught in moving parts.
5. Keep your eyes and mind on your tractor, mower, and the area being cut. Do not let other interests distract you.
6. Do not attempt to operate your tractor or mower when not in the driver's seat.
7. Always get on or off your tractor from the operator's left hand side.
8. Clear the work area of objects (wire, rocks, etc.) which might be picked up and thrown.
9. Disengage all attachment clutches before attempting to start the engine.
10. Disengage power to attachments and stop the engine before leaving the operator's position.
11. Disengage power to mower, stop the engine, and disconnect spark plug wire(s) from spark plug(s) before cleaning, making an adjustment, or repair. Be careful to avoid touching hot muffler or engine components.
12. Disengage power to attachments when transporting or not in use.
13. Take all possible precautions when leaving the vehicle unattended. Disengage the power take-off, lower the attachments, shift into neutral, set the parking brake, stop the engine, and remove the key.
14. Do not stop or start suddenly when going uphill or downhill. Mow up and down the face of slopes (not greater than 15°), never across the face. Refer to page 47.
15. Reduce speed on slopes and make turns gradually to prevent tipping or loss of control. Exercise extreme caution when changing direction on slopes.
16. While going up or down slopes, place gear shift control lever in 1st gear position to negotiate the slope without stopping.
17. Never mow in wet or slippery grass, when traction is unsure, or at a speed which could cause a skid.
18. Stay alert for holes in the terrain and other hidden hazards. Keep away from drop-offs.
19. Do not drive too close to creeks, ditches, and public highways.
20. Exercise special care when mowing around fixed objects in order to prevent the blades from striking them. Never deliberately run tractor or mower into or over any foreign objects.
21. Never shift gears until tractor comes to a stop.
22. Never place hands or feet under the mower, in discharge chute, or near any moving parts while tractor or mower is running. Always keep clear of discharge chute.
23. Use care when pulling loads or using heavy equipment.
  - a. Use only approved drawbar hitch points.
  - b. Limit loads to those you can safely control.
- c. Do not turn sharply. Use care when backing.
- d. Use counterweight or wheel weights when suggested in owner's manual.
24. Watch out for traffic when crossing or near roadways.
25. When using any attachments, never direct discharge of material toward bystanders nor allow anyone near the vehicle while in operation.
26. Handle gasoline with care - it is highly flammable.
  - a. Use approved gasoline containers.
  - b. Never remove the fuel cap of the fuel tank or add gasoline to a running or hot engine or an engine that has not been allowed to cool for several minutes after running. Never fill tank indoors. Always clean up spilled gasoline.
  - c. Open doors if the engine is run in the garage - exhaust fumes are dangerous. Do not run the engine indoors.
27. Keep the vehicle and attachments in good operating condition, and keep safety devices in place and working.
28. Keep all nuts, bolts, and screws tight to be sure the equipment is in safe working condition.
29. Never store the equipment with gasoline in the tank inside a building where fumes may reach an open flame or spark. Allow the engine to cool before storing in any enclosure.
30. To reduce fire hazard, keep the engine free of grass, leaves, or excessive grease. Do not clean product while engine is running.
31. Except for adjustments, DO NOT operate engine if air cleaner or cover directly over carburetor air intake is removed. Removal of such part could create a fire hazard.
32. Do not operate without a muffler, or tamper with exhaust system. Damaged mufflers or spark arresters could create a fire hazard. Inspect periodically and replace if necessary.
33. The vehicle and attachments should be stopped and inspected for damage after striking a foreign object, and the damage should be repaired before restarting and operating the equipment.
34. Do not change the engine governor settings or overspeed the engine; severe damage or injury may result.
35. When using the vehicle with mower, proceed as follows:
  - a. Mow only in daylight or in good artificial light.
  - b. Shut the engine off when unclogging chute.
  - c. Check the blade mounting bolts for proper tightness at frequent intervals.
36. Do not operate the mower without the entire grass catcher, on mowers so equipped, or the deflector shield in place.
37. Disengage power to mower before backing up. Do not mow in reverse unless absolutely necessary and then only after careful observation of the entire area behind the mower.
38. Under normal usage the grass catcher bag material is subject to deterioration and wear. It should be checked frequently for bag replacement. Replacement bags should be checked to ensure compliance with the original manufacturer's recommendations or specifications.

# 12 HP 38" RIDING LAWN TRACTOR - - MODEL NUMBER 917.254520 SCHEMATIC

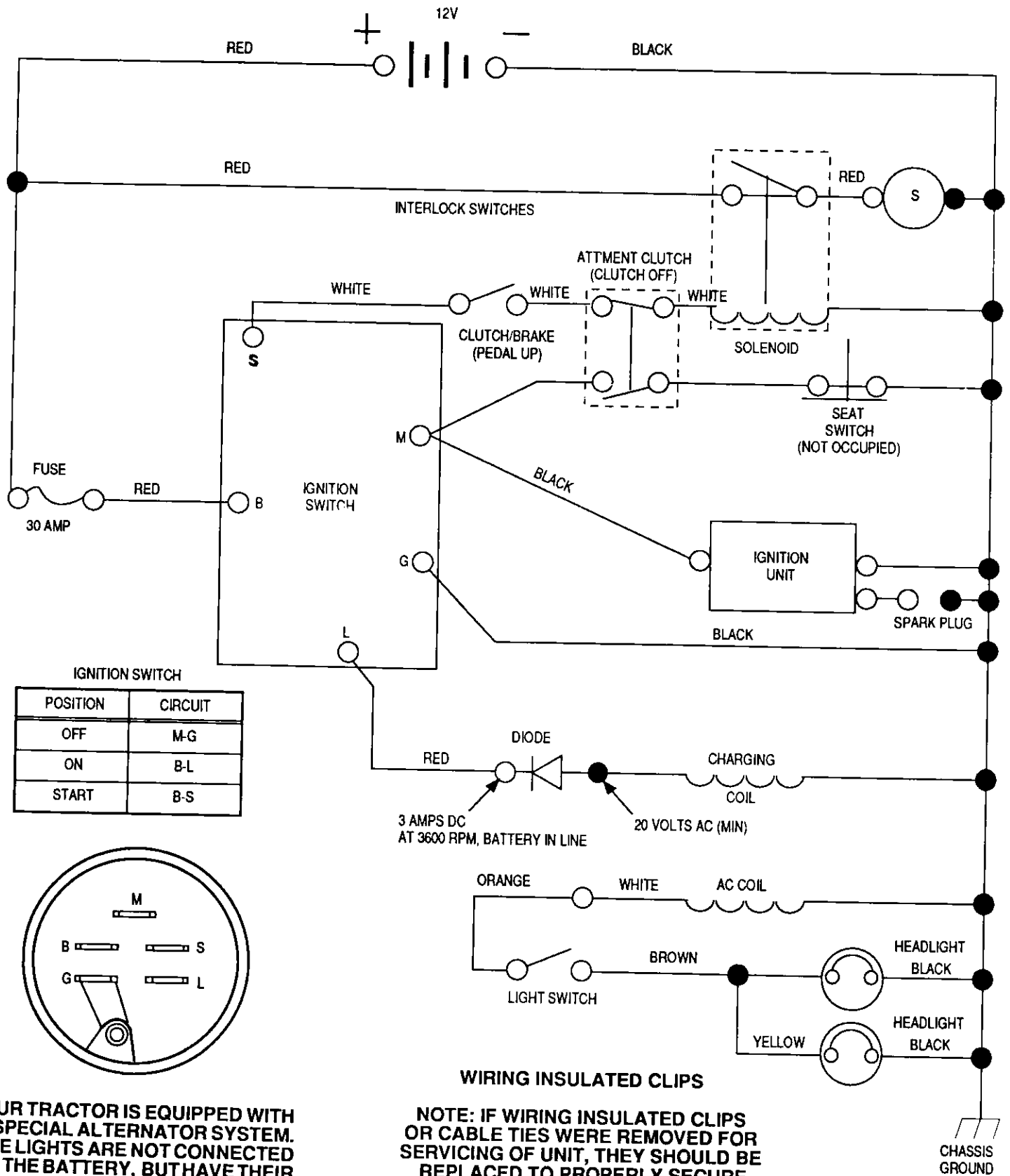

YOUR TRACTOR IS EQUIPPED WITH A SPECIAL ALTERNATOR SYSTEM. THE LIGHTS ARE NOT CONNECTED TO THE BATTERY, BUT HAVE THEIR OWN ELECTRICAL SOURCE. BECAUSE OF THIS, THE BRIGHTNESS OF THE LIGHTS WILL CHANGE WITH THE ENGINE SPEED. AT IDLE SPEED, THE LIGHTS WILL DIM. AS THE ENGINE IS SPEEDED UP, THE LIGHTS WILL BECOME THEIR BRIGHTEST.

**NOTE: IF WIRING INSULATED CLIPS OR CABLE TIES WERE REMOVED FOR SERVICING OF UNIT, THEY SHOULD BE REPLACED TO PROPERLY SECURE YOUR WIRING.**

● NON-REMOVABLE CONNECTIONS

○ REMOVABLE CONNECTIONS

# REPAIR PARTS 12 HP 38" RIDING LAWN TRACTOR -- MODEL NUMBER 917.254520

## ELECTRICAL

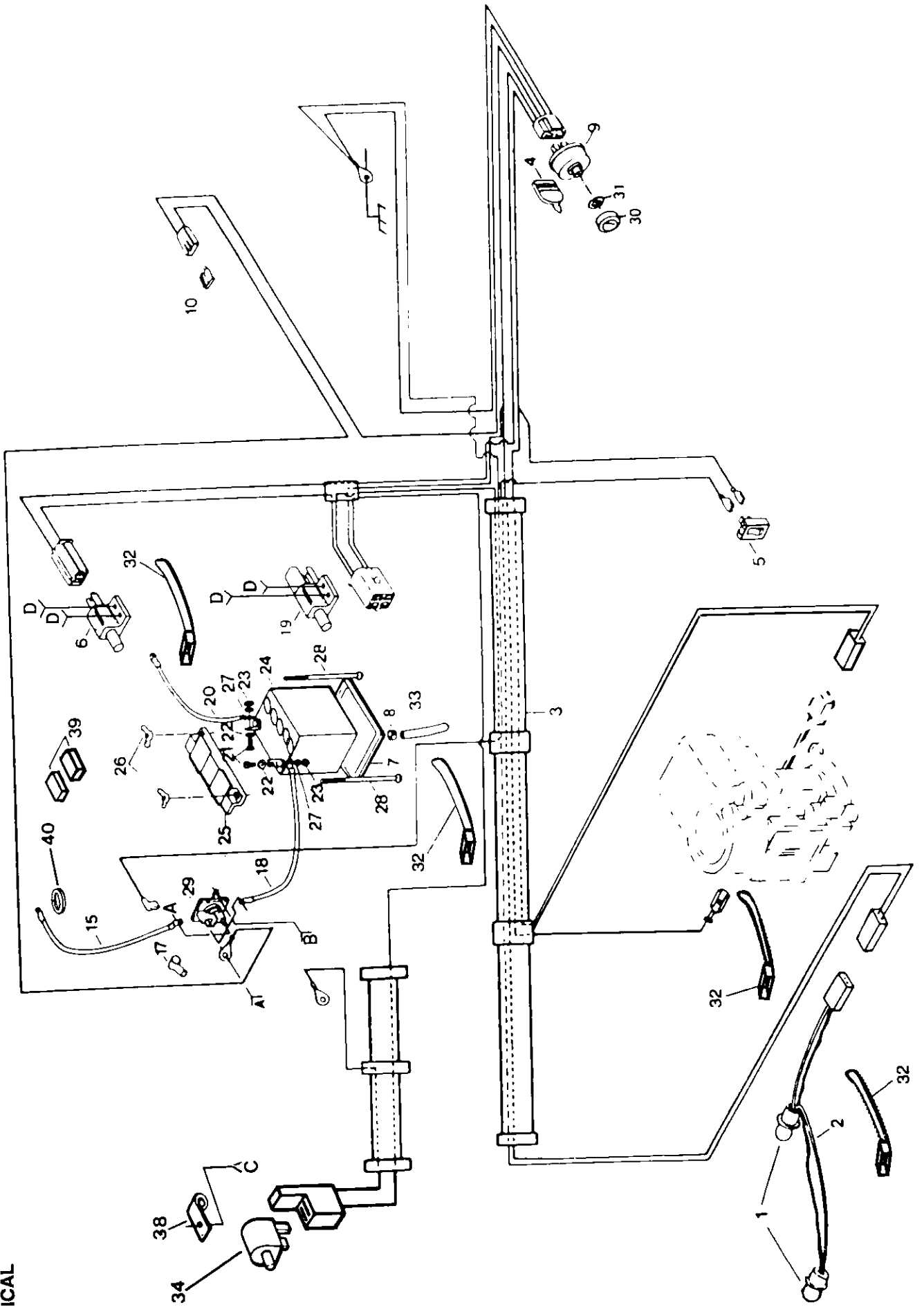

# REPAIR PARTS

## 12 HP 38" RIDING LAWN TRACTOR -- MODEL NUMBER 917.254520

### ELECTRICAL

KEY NO.	PART NO.	DESCRIPTION	KEY NO.	PART NO.	DESCRIPTION
1	7662J	Bulb, Light	28	72240460	Bolt - Rd. Hd. Sq. Nk. 1/4 - 20 x 7-1/2
2	124108X	Harness, Light Socket	29	109081X	Solenoid
3	124904X	Harness, Wiring	30	109787X	Bezel - Ignition
4	109310X	Key, Molded	31	109788X	Nut, Ignition
5	110712X	Switch, Light	32	7192J	Cable Tie
6	104445X	Switch, Interlock	33	105687X	Tube, Plastic
7	7603J	Tray, Battery	34	121305X	Switch, Plunger
8	109596X	Clamp, Hose	35	STD601005	Screw, Tap Hex Hd. #10 x 24 UNC
9	STD365402	Switch, Ignition	36	74641008	Screw - Slotted Pan Hd. No. 10-32 x 1/2
10	108824X	Fuse, 30 Amp	37	73951000	Nut - Keps No. 10-32 x 1/2
11	STD551125	*Washer, Lock, 1/4	38	4171R	Clip - Insulated
12	73350400	Nut, Hex Jam 1/4 - 20	39	121264X	Battery Caps Set
13	74780408	Bolt, Hex, 1/4 - 20 x 1/2 Gr. 5	40	11150400	Lockwasher 1/4 Internal Tooth
14	STD541425	* Nut, Keps 1/4 - 20	---	101539X	Sheet, Instruction, Tractor, 15° - English
15	4799J	Cable Assembly	---	126718X	Owner's Manual
16	11050400	Washer Lock, Ext. Tooth, 1/4			
17	719J	Cover, Terminal			
18	5114J	Cable, Battery			
19	109553X	Switch, Interlock			
20	4207J	Cable, Battery			
21	74760412	Bolt, Hex, 1/4 - 20 x 3/4			
22	STD551025	* Washer 9/32 x 5/8 x 16 Ga.			
23	STD541025	* Nut, Hex 1/4-20			
24	121265X	Battery, 12 V., 30 Amp			
25	102476X	Terminal Guard			
26	123198X	Wing Nut 1/4-20			
27	STD551125	* Washer, Lock Hvy Helical Spring			

NOTE: All component dimensions given in U.S. inches.  
1 inch = 25.4 mm.

\*STANDARD HARDWARE--PURCHASE LOCALLY

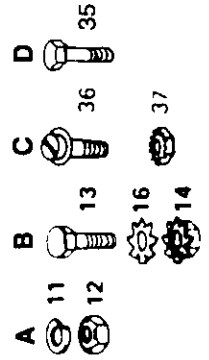

**REPAIR PARTS**  
**12 HP 38" RIDING LAWN TRACTOR -- MODEL NUMBER 917.254520**  
**CHASSIS AND ENCLOSURES**

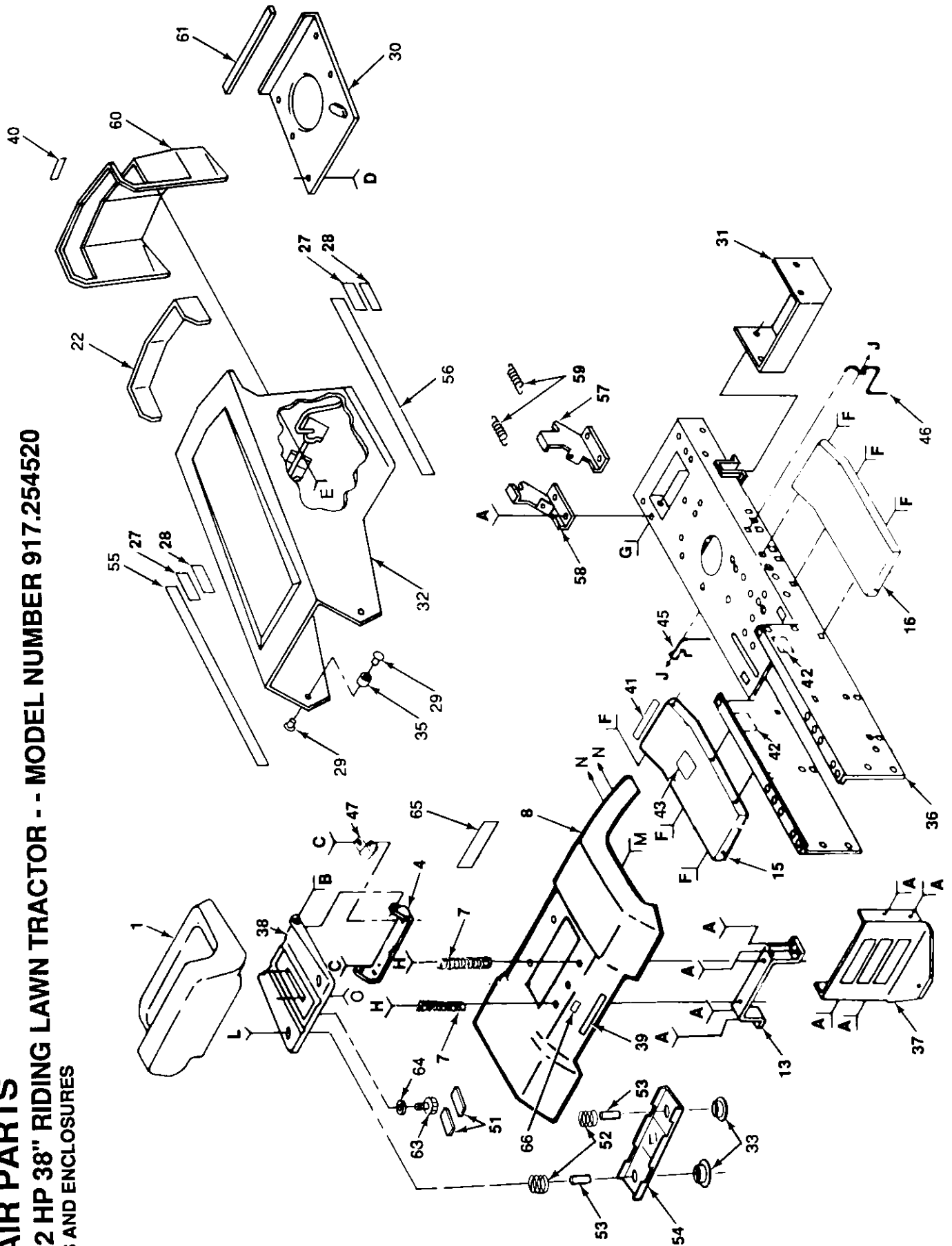

# REPAIR PARTS

## 12 HP 38" RIDING LAWN TRACTOR - - MODEL NUMBER 917.254520 CHASSIS AND ENCLOSURES

KEY NO.	PART NO.	DESCRIPTION	KEY NO.	PART NO.	DESCRIPTION
1	124497X	Seat	35	124479X	Washer, Black, Nylon
2	17490612	Screw, Hex Washer Thd. Roll 3/8-16 x 3/4	36	124355X	Chassis Assembly
3	17490616	Screw, Hex Washer Thd. Rolling 3/8-16 X 1	37	121306X	Drawbar
4	105513X	Bracket-Pivot, Seat	38	124294X	Pan - Seat
5	105529X	Bolt, Shoulder, 5/16 18	39	125880X	Decal - Fender
6	73680500	Nut - Crownlock 5/16 18	40	124492X	Decal, Grill, Craftsman
7	124181X	Spring, Seat	41	4900J	Decal, Clutch/Brake
8	109872X	Fender	42	105809X	Decal, Chassis, 5 Speed, 38"
9	STD523707	• Bolt, Fin Hex 3/8 x 16 UNC x 3/4	43	109199X	Decal, V-Belt Ground Drive
10	17030808	Screw, Spiderlock Hex #8 x 1/2 AB	44	19132012	Washer 13/32 x 1-1/4 x 12 Ga.
11	73680600	Nut, Crownlock 3/8-16	45	121440X	Guide - Belt, Lower, Eng. Pulley, L.H.
12	17490608	Screw, Hex Washer Thd Roll 3/8 16 x 1/2	46	121441X	Guide Belt, Lower, Eng. Pulley R.H.
13	109873X	Bracket, Fender	47	2751R	Clip
14	STD512505	• Bolt, Fin Hex 1/4 - 20 UNC x 1/2	48	19131614	Washer 13/32 x 1 x 14 Ga.
15	105476X	Footrest, L.H.	49	72170410	Bolt, RdHd 1/4 x 20 x 1-1/4
16	105475X	Footrest, R.H.	50	123976X	Nut, Hex, Lg., Flange, Loc. 1/4-20
17	STD533707	• Bolt, RdHdSqNk 3/8 - 16 UNC x 3/4	51	121251X	Strip, Foam
19	STD551125	• Washer, Lock, Hvy Helical Spring	52	121250X	Spring, Seat, Compression
20	STD523710	• Bolt, Fin Hex 3/8 x 16 UNC x 1	53	121249X	Spacer, Split
21	19131312	Washer 13/32 x 13/16 x 12 Ga.	54	121246X	Bracket, Switch Mount
22	124029X	Lens Assembly	55	124489X	Decal Stripe Hood L.H.
24	19131210	Washer 13/32 x 3/4 x 10 Ga	56	124490X	Decal Stripe Hood R.H.
27	124491X	Decal, 12 HP	57	123913X	Bracket, Pivot, R.H.
28	108631X	Decal, II	58	123914X	Bracket, Pivot, L.H.
29	122933X	Rivet, Ratchet, Nylon	59	124040X	Spring, Extension
30	124027X	Shield, Hood, Heat	60	123915X	Grill
31	123665X	Deflector, Heat	61	105037X	Foam, Strip 18"
32	124025X	Hood Assembly	62	121144X	Bolt, Shoulder
33	121248X	Bushing, Snap	63	STD525010	• Bolt, Fin Hex 1/2 - 13 UNC x 1 Gr. 5
34	STD541437	• Nut, Crownlock 3/8 x 16 UNC	64	19171912	Washer 17/32 x 1-3/16 x 12 Ga.
			65	106974X	Decal, Caution
			66	750211	Decal, USA

NOTE: All component dimensions given in U.S. inches.  
1 inch = 25.4 mm.

\* STANDARD HARDWARE PURCHASE LOCALLY

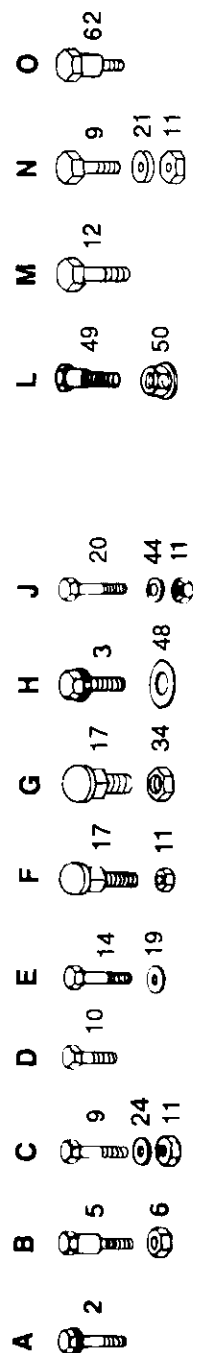

# REPAIR PARTS

## 12 HP 38" RIDING LAWN TRACTOR - - MODEL NUMBER 917.254520

DRIVE

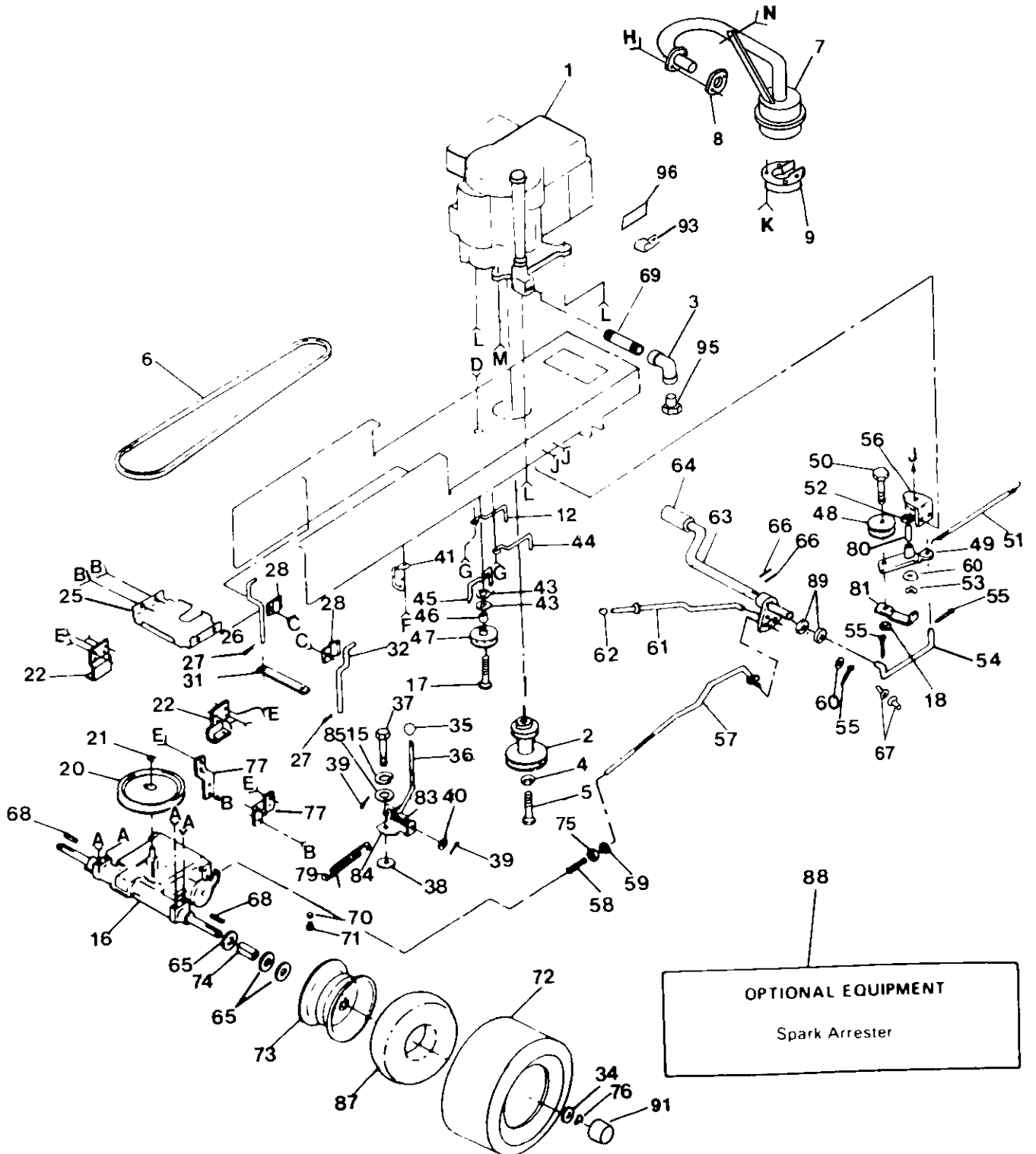



# REPAIR PARTS

## 12 HP 38" RIDING LAWN TRACTOR - - MODEL NUMBER 917.254520

### DRIVE

KEY NO.	PART NO.	DESCRIPTION	KEY NO.	PART NO.	DESCRIPTION
1	124136X	Engine, 12 HP, Briggs and Stratton, Model Number 281707, Type Number 0412-01	48	123766X	Pulley, Idler
2	105731X	Pulley, Engine	49	123789X	Arm, Idler
3	13200300	Elbow - STD 90 3/8 - 18 NPT	50	STD523715	* Bolt, Hex 3/8-16 x 1-1/2
4	STD551143	* Washer, Lock, Hvy Helical Spring	51	105709X	Spring, Return, Clutch
5	74770720	Bolt, Hex 7/16-20 x 1-1/4	52	110812X	Washer, Hardened
6	125907X	V-Belt, Drive	53	12000039	Ring, Klip
7	125610X	Muffler	54	105710X	Link, Clutch
8	125593X	Gasket	55	STD561210	* Pin, Cotter 1/8 x 3/4
9	101326L	Deflector, Muffler	56	123102X	Bracket, Clutch
10	71070510	Hex Hd. Cap Screw 5/16-18 x 5/8	57	110437X	Rod, Brake
11	STD551131	* Washer, Lock 5/16	58	106888X	Spring, Rod, Brake
12	121218X	Keeper, Belt, Engine	59	73350600	Nut Jam 3/8 16
13	73220500	Nut, Hex 5/16 x 18	60	19131316	Washer 13/32 x 13/16 x 16 Ga
14	17490620	Screw, Hex Washer Thd. Rolling 3/8 x 16 x 1-1/4	61	125638X	Rod, Brake, Parking
15	STD551125	* Washer, Lock, Hvy. Helical Spring	62	124236X	Cap Plunger
16	120897X	Transaxle, Foote-Dana, 5 Speed, Model No. 4360-6	63	122424X	Shaft, Foot Pedal
17	STD523727	* Bolt, Hex 3/8 16 x 2 3/4	64	8883R	Cover - Pedal
18	STD541437	* Nut, Crownlock 3/8-16	65	121749X	Washer 25/32 x 1-1/4 x 16 Ga
19	73680500	Nut, Crownlock 5/16 - 18	66	STD571810	* Pin, Roll, 3/16 x 1
20	123666X	Pulley, Transaxle	67	120183X	Bearing, Nylon
21	12000028	Ring, Retainer	68	123583X	Key, Square, 2.5 x .1845/.1865
22	109167X	Bracket Transaxle	69	13280324	Nipple, Pipe 3/8 NPT 3"
23	STD523710	* Bolt, Hex 3/8-16 x 1	70	59192	Cap, Valve
24	17490512	Screw, Hex Washer Thread Rolling 5/16-18 x 3/4	71	65139	Stem, Valve
25	108171X	Support, Battery	72	123969X	Tire, Rear
26	123662X	Keeper, Belt, L.H.	73	106108X	Rim Assembly, 8", Rear
27	4921H	Retainer, Spring	74	109502X	Spacer
28	106190X	Clamp	75	736800600	Locknut, Hex, w/washer Insert 3/8-16
29	STD523107	* Bolt, Hex 5/16-18 x 3/4	76	12000001	E-Ring
30	STD541437	* Nut, Crownlock 3/8 - 16	77	121520X	Strap, Torque, Transaxle
31	123770X	Strap, Locator	78	STD533707	* Bolt, Carriage 3/8-16 x 3/4
32	123663X	Keeper, Belt, R.H.	79	110422X	Spring - Brake
33	STD523707	* Bolt, Hex 3/8-16 x 3/4	80	105706X	Bearing
34	121748X	Washer 25/32 x 1.5/8 x 16 Ga.	81	123205X	Retainer - Belt
35	106933X	Knob, Shift	82	17030808	Screw - Spider Lock No. 8-18 x 1/2 ABTPS
36	124461X	Rod, Shift	83	105700X	Spring
37	71040412	Bolt - Hex 1/4-28 x 3/4	84	106919X	Plate, Shift
38	105701X	Washer - Shift Plate	85	19091210	Washer 9/32 x 3/4 x 10 Ga.
39	STD561210	* Cotter Pin, 1/8 x 1	86	11050600	Washer, Lock, Ext. Tooth 3/8
40	19151216	Washer 15/32 x 3/4 x 16 Ga.	87	7152J	Tube, Tire (not furnished with tractor)
41	104777X	Retainer, Belt	88	121851X	Spark Arrester
42	17490612	Screw, Hex Washer Thd. Rolling 3/8 16 x 3/4	89	STD551062	* Washer 21/32 x 1 x 16 Ga.
43	19131312	Washer 13/32 x 13/16 x 12 Ga.	90	STD523727	* Bolt, Hex 3/8 x 16 x 2-3/4
44	105730X	Keeper, Belt, Engine	91	104757X	Cap, Hub
45	109070X	Retainer Belt	92	STD551025	* Washer 9/32 x 5/8 x 16 Ga.
46	4470J	Spacer	93	2751R	Clip, Fuel Line
47	123674X	Idler, Flat	94	STD522510	* Bolt, Hex Fin 1/4 x 20 UNC x 1
			95	13290300	Oil Drain Plug
			96	126685X	Decal, 12 HP, Craftsman, Engine

\*STANDARD HARDWARE--PURCHASE LOCALLY  
 NOTE: All component dimensions given in U.S. inches.  
 1 inch = 25.4 mm.

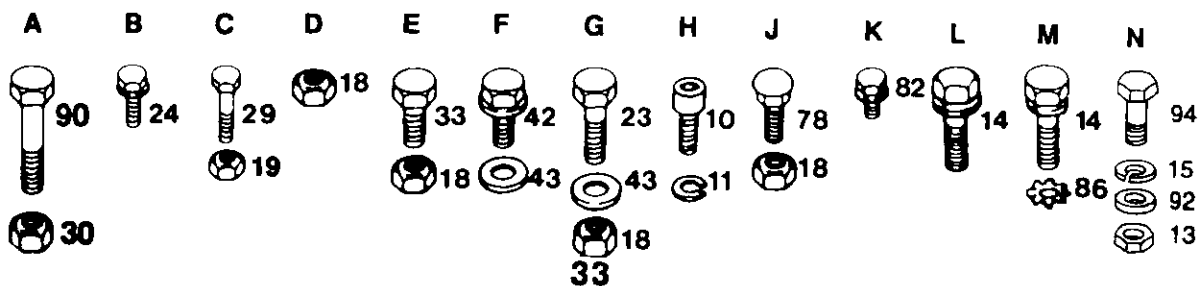



# REPAIR PARTS

## 12 HP 38" RIDING LAWN TRACTOR - - MODEL NUMBER 917.254520

### STEERING ASSEMBLY

KEY NO.	PART NO.	DESCRIPTION	KEY NO.	PART NO.	DESCRIPTION
1	123042X012	Dash	36	124033X	Shaft, Pitman
2	74180512	Screw - Truss Hd. 5/16-18 x 3/4	37	105663X	Support Saddle, Rear
3	73510500	Nut - Keps 5/16 - 18	38	105664X	Support Saddle, Front
4	109816X	Nyliner, Snap In	39	74761060	Bolt - Hex 5/8-11 x 3-3/4
5	124434X	Control - Throttle	40	105669X	Axle - Front
6	STD522510	• Screw, Hex Thread Cut 1/4 x 20 x 5/8	41	110438X	Spacer, Bearing, Front Axle
7	126684X	Washer 5/8 x 1/4 x 16 Ga.	42	73901000	Nut - Lock, Flange 5/8-11
8	124417X	Boot, Steering Shaft	43	17490508	Screw - Hex Washer Thread Rolling 5/16-18 x 1/2 Type TT
9	124465X014	Saddle	44	124037X	Gear, Pinion
10	17490608	Screw - Hex Washer Hd. Thread Rolling 3/8-16 x 1 2	45	3366R	Bearing
11	2751R	Clip - Insulated	46	105715X	Rod - Tie
12	125879X	Decal - Steering Wheel Cap	47	120754X	Bushing
13	100710L	Insert - Steering Wheel	48	19131416	Washer 13/32 x 7/8 x 16 Ga
14	STD541350	• Nut - Hex Jam Lock 1/2-20	49	76020412	Pin - Cotter 1/8 x 3/4
15	100712K	Washer 2-1/4	50	STD551137	• Washer Lock 3/8
16	100713N	Wheel - Steering	51	73610600	Nut, Fin Hex 3/8 x 24 UNF
17	100711L	Adapter - Steering Wheel	52	124032X	Link - Drag
18	STD551125	• Lockwasher 1/4	53	105656X	Spindle - L.H.
19	71070410	Screw, Socket Hex 1/4 x 20 x 5/8	54	105654X	Spindle - R.H.
20	124030X	Bumper, Hood	55	278H	Fitting - Grease
21	5479J	Plug, Button	56	9040H	Bearing - Flange
22	STD611005	• Screw - Hex Self Tap No 10-16 x 1/2 Type ABTPS	57	106732X	Rim - 6" Front (Inc. 2 Each Key No. 56)
23	108456X	Decal - Instruction, Operating	58	59192	Cap - Valve
24	124373X	Bushing - Steering	59	65139	Stem - Valve
25	124036X	Bracket - Steering	60	124157X	Tire, Front
26	17490612	Screw - Hex Washer Thread Rolling 3/8-16 x 3/4 Type TT	61	121749X	Washer 25/32 x 1-1/4 x 16 Ga
27	6266H	Bearing - Thrust	62	59904	Tube - Front (Not furnished with tractor)
28	124034X	Gear - Sector	64	121748X	Washer 25/32 x 1-5/8 x 16 Ga.
29	124035X	Shaft, Support	65	STD551231	• Washer, Lock, Int Tooth 5/16
30	12000029	Klip Ring	66	110307X	Stop, Mower Clutch
31	57079	Washer, Hardened	67	19272016	Washer 2 7/32 x 1-1/4 x 16 Ga
32	124038X	Shaft, Steering, Lower	68	121232X	Cap, Spindle
33	122819X	Screw, Special			
34	104757X	Cap, Hub			

\*STANDARD HARDWARE PURCHASE LOCALLY

NOTE: All component dimensions given in U.S. inches.  
1 inch = 25.4 mm.

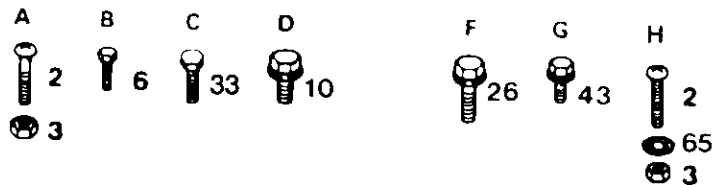

# REPAIR PARTS

## 12 HP 38" RIDING LAWN TRACTOR -- MODEL NUMBER 917.254520

### LIFT ADJUSTMENT

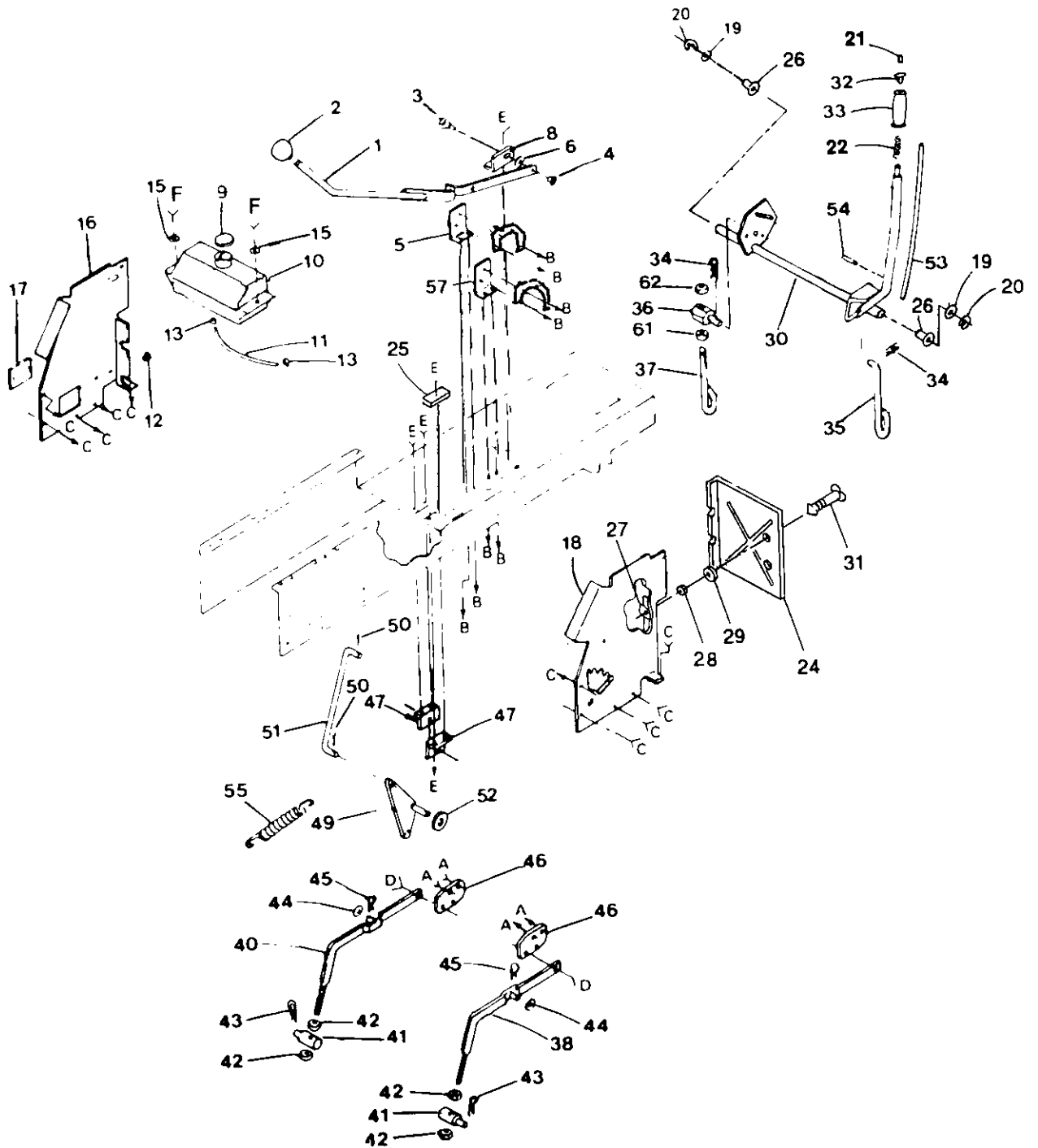

# REPAIR PARTS

## 12 HP 38" RIDING LAWN TRACTOR - - MODEL NUMBER 917.254520

### LIFT ADJUSTMENT

KEY NO.	PART NO.	DESCRIPTION	KEY NO.	PART NO.	DESCRIPTION
1	124429X	Lever, Clutch, Mower	32	122364X	Plunger
2	106932X	Knob	33	125631X	Grip, Handle
3	106451X	Bolt, Shoulder	34	4939M	Retainer, Spring
4	73680600	Nut, Crownlock 3/8-16	35	110029X	Link, Lift
5	106452X	Bracket, Switch, Interlock	36	110447X	Trunnion, Lift
6	19171516	Washer 17/32 x 15/16 x 16 Ga.	37	110448X	Link, Lift, Adjustable
7	17021008	Screw, Hex, Tapping, No 10-24 x 1/2	38	121598X	Arm, Suspension, R.H.
8	106447X	Support, Lever, Clutch	39	105848X	Bolt, Shoulder, 3/8-16
9	123549X	Cap, Fuel	40	121599X	Arm, Suspension, L.H.
10	109202X	Tank, Fuel	41	106308X	Trunnion, Lift, Lower
11	101335K	Line, Fuel	42	STD541050	* Nut Hex 1/2-13
12	124028X	Grommet	43	9135R	Retainer, Spring
13	123487X	Clamp, Hose	44	19171516	Washer 17/32 x 15/16 x 16 Ga
14	17490612	Screw, Hex Washer Thd. Rolling 3/8 x 16 x 3/4	45	4921H	Retainer, Spring
15	19091416	Washer 9/32 x 7/8 x 16 Ga.	46	105864X	Bracket, Suspension
16	122795X	Panel, Dash, L.H	47	106444X	Bracket, Bellcrank
17	121794X	Cover, Access	48	STD523707	* Bolt, Hex 3/8 16 x 3/4
18	124031X012	Panel, Dash, R H	49	109728X	Bellcrank Assembly
19	19211416	Washer 21/32 x 7/8 x 16 Ga.	50	STD561210	* Pin, Cotter, 1/8 x 3/4
20	STD581062	* E Ring	51	124444X	Rod, Clutch, Primary
21	122365X	Button, Plunger	52	19131410	Washer 13/32 x 7/8 x 10 Ga
22	122512X	Spring, Compression	53	122514X	Rod Assembly Lever
23	17490412	Screw, Hex Washer Thd. Rolling 1/4 -20 x 3/4	54	105767X	Pin Groove
24	105736X	Shield, Heat	55	124446X	Spring Extension
25	5320R	Clip, Insulated	56	72140606	Screw 3/8-16 x 3/4
26	120183X	Bearing, Nylon	57	108236X	Bracket, Switch
27	105839X	Receptacle, 1/4 Turn	59	110739X	Washer - Spring
28	105838X	Retainer, 1/4 Turn	60	73980600	Nut Flangelock 3/8-16
29	STD551025	* Washer 9/32 x 5/8 x 16 Ga.	61	73360700	Nut, Hex Jam 7/16-20
30	122507X	Shaft, Lift	62	73710700	Nut, Crownlock 7/16-20
31	105751X	Stud, 1/4 Turn			

\* STANDARD HARDWARE PURCHASE LOCALLY

NOTE: All component dimensions given in U.S. inches.  
1 inch = 25.4 mm.

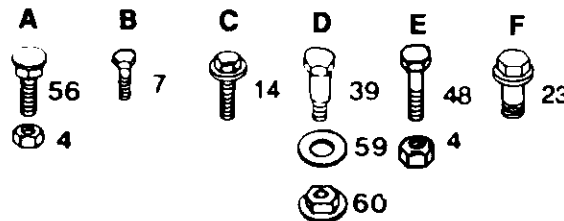

# REPAIR PARTS

12 HP 38" RIDING LAWN TRACTOR - - MODEL NUMBER 917.254520  
38" MOWER

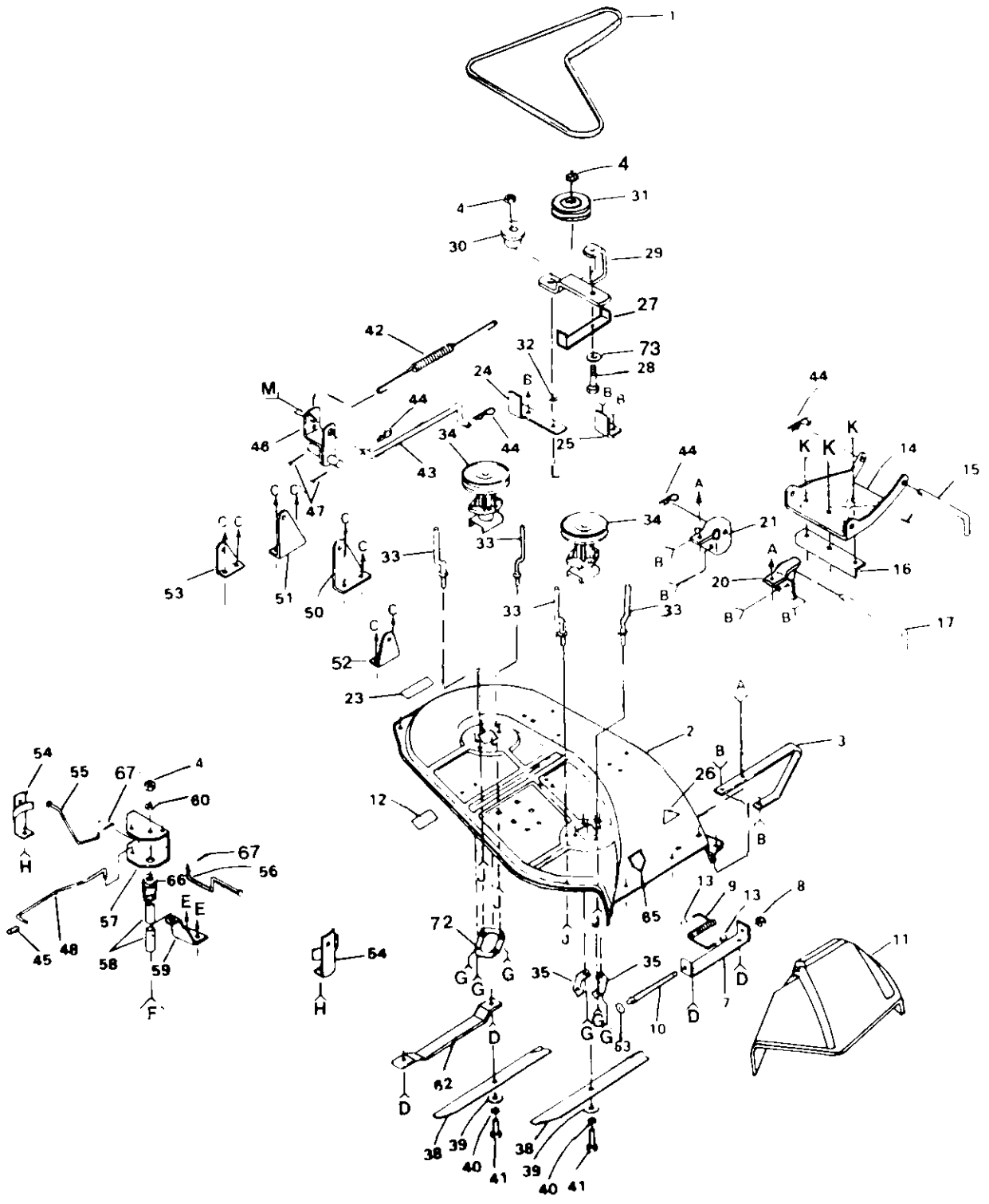

# REPAIR PARTS

## 12 HP 38" RIDING LAWN TRACTOR - - MODEL NUMBER 917.254520

38" MOWER

KEY NO.	PART NO.	DESCRIPTION	KEY NO.	PART NO.	DESCRIPTION
1	106085X	V-Belt	38	121263X	Blade
2	121259X	Housing	39	19132012	Washer 13/32 x 1-1/4 x 12 Ga
3	8417J	Runner, R.H.	40	STD551137	Washer, Lock 3/8
4	73680600	Nut, Crownlock 3/8-16	41	STD623715	Bolt, Hex, 3/8-24 x 1-1/2 Gr. 5
5	19111216	Washer 11/32 x 3/4 x 16 Ga.	42	108250X	Spring, Extension
6	72140505	Bolt, Carr., 5/16 - 18 x 5/8	43	108235X	Rod - Clutch, Mower
7	105896X	Bracket, Deflector	44	4921H	Spring - Retainer
8	110452X	Pushnut	45	6404J	Spacer 1/2 x 9/16
9	106734X	Spring, Deflector	46	124066X	Rock Shaft Assembly
10	106735X	Rod - Hinge	47	76020616	Pin, Cotter, 3/16 x 1
11	106736X	Deflector - Shield	48	108247X	Rod, Brake, Primary
12	105814X	Decal, V-Belt Mower Drive	49	72140606	Bolt, Carr. 3/8-16 x 3/4
13	105304X	Cap	50	108243X	Bracket, Pivot, R.H.
14	105662X	Link, Parallel	51	108241X	Bracket, Pivot, L.H.
15	105744X	Pin - Hinge, Front	52	105857X	Bracket, Suspension, Rear, R.H.
16	105872X	Stop, Link	53	108673X	Bracket, Suspension, Rear, L.H.
17	109835X	Pin - Hinge, Rear	54	106578X	Brake Assembly
18	STD523707	Bolt 3/8-16 x 3/4	55	106463X	Rod, Brake, Secondary, L.H.
19	73680500	Nut, Crownlock 5/16-18	56	108249X	Rod, Brake, Secondary, R.H.
20	109598X	Bracket, Lift, R.H.	57	106456X	Bracket, Brake, Pivot
21	109597X	Bracket, Lift, L.H.	58	100672K	Spacer, Brake
22	STD533107	Bolt, Carr. 5/16-18 x 3/4	59	100673L	Bracket, Support
23	3713J	Decal, Instruction Caution	60	19131614	Washer 13/32 x 1 x 14 Ga.
24	109503X	Support, Arm	61	74760688	Bolt, 3/8-16 x 5-1/2
25	109504X	Stop, Deck, Front	62	7631J	Runner, L.H.
26	- - -	Decal - Safety Standard - Not Serviced	63	19111016	Washer 11/32 x 5/8 x 16 Ga.
27	123204X	Guide Belt	64	72140610	Bolt, 3/8-16 x 1-1/4
28	74760632	Bolt 3/8-16 x 2	65	121343X	Decal - Warning
29	123553X	Arm, Idler	66	122314X	Spacer
30	106902X	Spacer - Retainer	67	STD560907	Pin, Cotter, 3/32 x 1/2
31	121316X	Pulley - Idler	68	72110506	Bolt, Carriage 5/16-18 x 3/4
32	106513X	Washer, Wear, 1/16	69	74760412	Bolt Hex 1/4-20 x 3/4
33	102669X	Keeper, Belt	70	109893X	Washer, Special
34	121687X	Mandrel Assembly	71	73680400	Nut, Crownlock 1/4-20
35	100668L	Plate, Support Mandrel	72	110445X	Plate, Support, Mandrel, L.H.
36	17490614	Screw, Hex Washer Hd. 3/8 x 16 x 7/8	73	STD551037	Washer 13/32 x 13/16 x 16 Ga.
37	17490620	Screw, Hex Washer Hd. 3/8 x 16 x 1-1/4	-	122215X	Mower Assembly, Complete

\* STANDARD HARDWARE - - PURCHASE LOCALLY

NOTE: All component dimensions given in U.S. inches.  
1 inch = 25.4 mm.

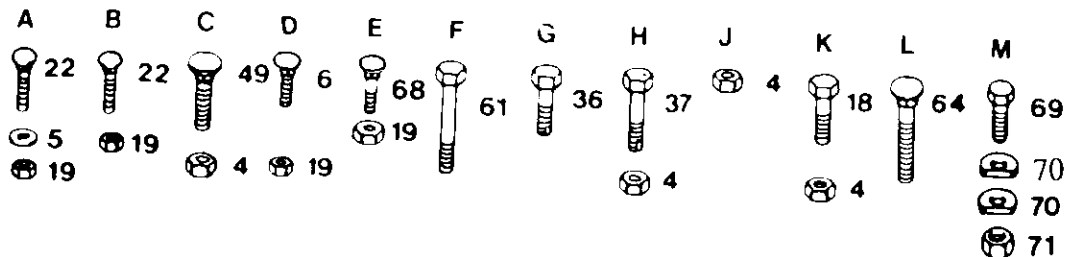





# REPAIR PARTS

## 12 HP 38" RIDING LAWN TRACTOR - - MODEL NUMBER 917.254520 TRANSAXLE FOOTE - MODEL NUMBER 4360-6

### TRANSAXLE

KEY NO.	PART NO.	DESCRIPTION	KEY NO.	PART NO.	DESCRIPTION
1	120458X	Housing, Upper	39	120471X	Shaft, Idler
2	2274J	Screw, Tapping, 1/4-20 x .734 Lg.	40	120472X	Spacer, .635 x .875 x .755
3	68003	Ball, Detent	41	105928X	Sprocket, 9T
4	105904X	Spring, Detent	42	110084X	Gear, Bevel, 42T.
5	105905X	Screw, Set	43	108983X	* Washer, Plain, .758 x 1.12 x .010
6	120460X	Ass'y., Shifter	43	105930X	* Washer, Plain, .758 x 1.12 x .015
7	120461X	O-Ring	43	105931X	* Washer, Plain, .758 x 1.12 x .020
8	120462X	* Washer, Plain, .505 x .942 x .006	43	105932X	* Washer, Plain, .758 x 1.12 x .025
8	120463X	* Washer, Plain, .505 x .942 x .010	43	3417J	* Washer, Plain, .758 x 1.25 x .020
8	120464X	* Washer, Plain, .505 x .942 x .015	43	106097X	* Washer, Plain, .758 x 1.25 x .025
8	120465X	* Washer, Plain, .505 x .942 x .020	43	2264J	* Washer, Plain, .758 x 1.25 x .031
8	120466X	* Washer, Plain, .505 x .942 x .026	43	106098X	* Washer, Plain, .758 x 1.25 x .035
8	83818	* Washer, Plain, .505 x .942 x .030	43	2265J	* Washer, Plain, .758 x 1.25 x .040
8	120467X	* Washer, Plain, .505 x .942 x .040	43	106586X	* Washer, Plain, .758 x 1.25 x .045
9	2286J	Ring, Retaining	43	106587X	* Washer, Plain, .758 x 1.25 x .050
10	2267J	Ring, Retaining	43	106588X	* Washer, Plain, .758 x 1.25 x .055
11	3413J	Washer, Plain, .632 x 1.00 x .010	43	2263J	* Washer, Plain, .758 x 1.25 x .062
11	2233J	Washer, Plain, .632 x 1.00 x .020	44	120473X	Shaft, Drive
11	2232J	Washer, Plain, .632 x 1.00 x .026	45	105933X	Gear, Spur, 12T.
11	2231J	Washer, Plain, .632 x 1.00 x .031	46	120407X	Gear, Spur, 20T.
11	2230J	Washer, Plain, .632 x 1.00 x .036	47	106589X	Gear, Spur, 25T.
11	2229J	Washer, Plain, .632 x 1.00 x .041	48	120408X	Gear, Spur, 28T.
11	2228J	Washer, Plain, .632 x 1.00 x .046	49	105937X	Gear, Spur, 31T.
11	2227J	Washer, Plain, .632 x 1.00 x .050	50	105936X	Spacer, .781 x 1.00 x .375
11	2226J	Washer, Plain, .632 x 1.00 x .060	51	2226J	Washer, Plain, .632 x 1.00 x .060
11	105906X	Washer, Plain, .632 x 1.00 x .082	52	2272J	Seal, Felt
12	6725J	O-Ring	53	2263J	Washer, Plain, .758 x 1.25 x .062
13	120415X	Washer, Plain, .632 x 1.38 x .046	54	120474X	Axle, L.H.
14	2257J	Key, Woodruff, #9	55	110081X	Gear, Miter, 15T.
15	110077X	Ass'y., Kit, Input Shaft	56	105941X	Ring, Retaining
16	110078X	Pinion, Bevel, 14T.	57	110071X	Gear, Spur, 32T.
17	105909X	Ring, Retaining	58	120952X	Shaft, Cross
18	105910X	Chain, 24 Pitches	59	110082X	Gear, Miter, 15T.
19	105911X	Bearing, Flange	60	120475X	Axle, R.H.
20	108976X	Gear, Spur, 14T.	61	120476X	Housing, Lower
21	105913X	Collar, Clutch	62	120961X	Puck, Friction
22	120468X	Key, Clutch	63	64260	Disc, Brake
23	2242J	Key, Woodruff, #3	64	108989X	Spacer
24	120469X	Shaft, Intermediate	65	120953X	Ass'y, Jaw, Brake
25	2244J	Key, Woodruff #61	66	120954X	Pin, Dowel
26	105916X	Ring, Retaining	67	120955X	Screw, Tapping, 5/16 - 18 x 2.25
27	120470X	Sprocket, 18T.	68	108992X	Lever, Actuating
28	110070X	Spacer	69	108996X	Washer, Plain, .321 x 1.00 x .055
29	108977X	Gear, Spur, 37T.	70	120956X	Bracket, Anti-Rotation
30	120405X	Gear, Spur, 30T.	71	73810500	Nut, Lock 5/16-24
31	108980X	Gear, Spur, 25T.	72	106596X	Screw, Tapping, 5/16 - 18 x 1.44 Lg.
32	120406X	Gear, Spur, 22T.	73	120993X	Washer, Plain, .343 x .81 x .059
33	108455X	Gear, Spur, 19T	74	120951X	Puck, Friction
34	105923X	Spacer, 1.13 x 1.50 x .375	75	120416X	Grease
35	105925X	Washer, Plain, .640 x 1.37 x .061			
36	2232J	Washer, Plain, .632 x 1.00 x .026			
37	108978X	Spacer, .630 x 1.00 x .169			
38	110079X	Ass'y., Gear, Combo., 12T. & 35T.			

\*Use in various combinations to maintain proper clearances.

\*\*Order Key No. 15.

NOTE: All component dimensions given in U.S. inches.  
1 inch = 25.4 mm

# REPAIR PARTS

12 HP 38" RIDING LAWN TRACTOR - - MODEL NUMBER 917.2546520  
ENGINE BRIGGS AND STRATTON - MODEL NUMBER 281707, TYPE NUMBER 0412-01

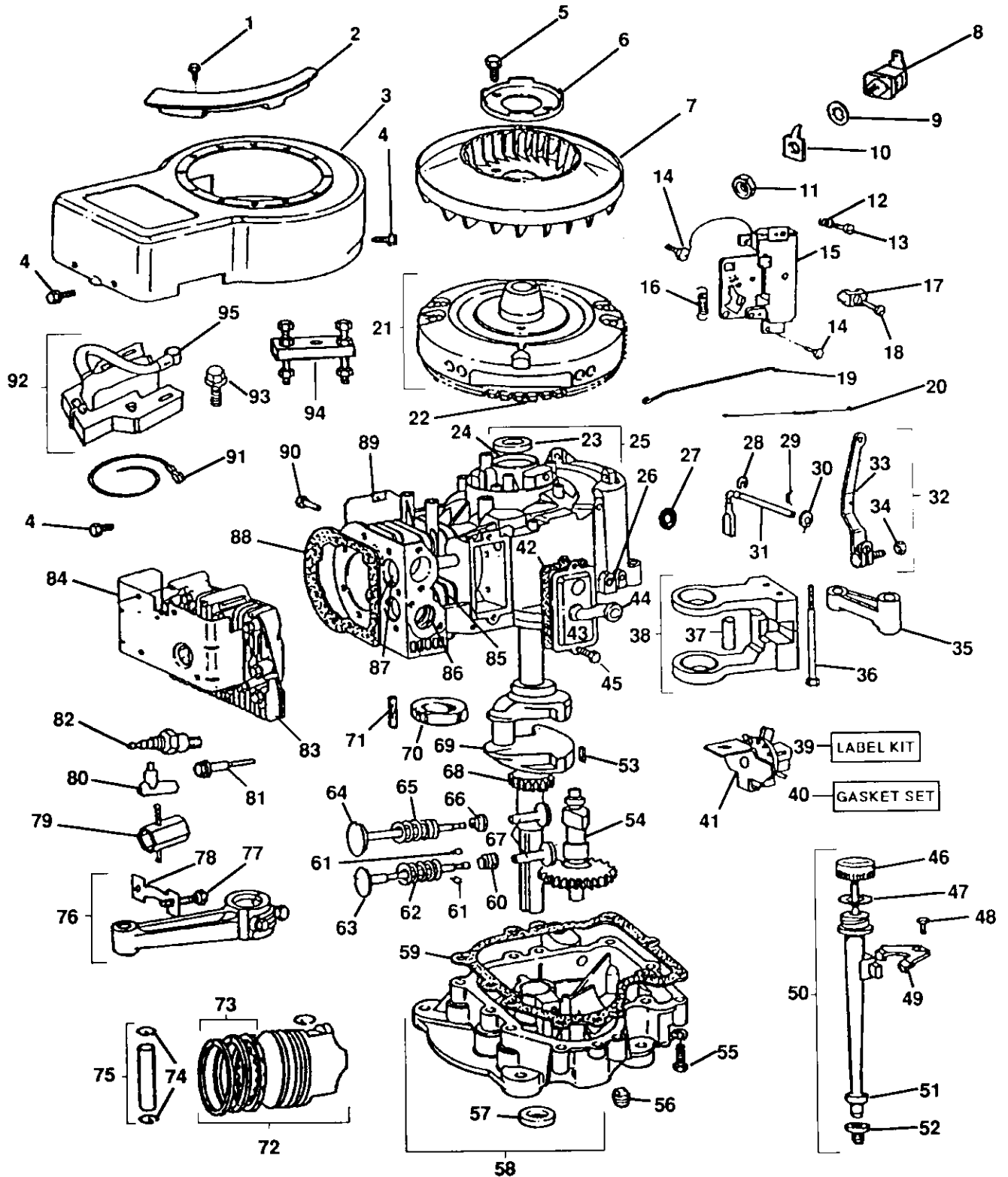

# REPAIR PARTS

12 HP 38" RIDING LAWN TRACTOR - - MODEL NUMBER 917.254520

ENGINE BRIGGS & STRATTON - MODEL NUMBER 281707, TYPE NUMBER 0412-01

KEY NO.	PART NO.	DESCRIPTION	KEY NO.	PART NO.	DESCRIPTION
1	93705	Screw-Hex Head	57	291675	Seal-Oil
2	223752	Guard-Flywheel	58	490452	Base-Engine
3	490854	Housing-Blower	59	271916	* Gasket-Crankcase Cover-1/64" thick
4	93158	Screw-Blower Housing Mounting Sem		271996	* Gasket-Crankcase Cover-.005" thick
5	93535	Screw-Sem (3/4" Long)		271997	* Gasket-Crankcase Cover-.009" thick
6	223726	Retainer-Fan	60	292260	Rotocoil Exhaust Valve
7	280687	Fan-Flywheel	61	93630	Retainer-Exhaust Valve Rotocoil (2)
8	398525	Insulator Assembly	62	26828	Spring-Exhaust Valve
9	92791	Washer Lock- Shakeproof	63	262246	Valve-Exhaust
10	93722	Terminal-Spade	64	262247	Valve-Intake
11	90576	Nut-Hex. 8-32	65	65906	Spring-Intake Valve
12	26157	Spring-Throttle Adjustment	66	221596	Retainer-Intake Valve
13	90200	Screw-Machine, Fill. Hd. 8-32 x 1/2"	67	262248	Tappet-Valve
14	93572	Screw-Carburetor	68	262135	Gear-Timing
15	491594	Plate-Governor Control (Choke-A-Matic)	69	490466	Crankshaft
16	260695	Spring Governor			NOTE: Order Part Number 94196 For Timing Gear Key
17	221535	Clamp Casing	70	262243	Eccentric
18	93496	Screw-Sem	71	94160	Pin-Eccentric
19	262348	Link Governor	72	394661	Piston Assy.-Standard
20	260584	Spring Governor Link		394662	Piston Assy.-.010" O.S.
21	492325	Flywheel and Ring Gear Assy.-Magneto		394663	Piston Assy.-.020" O.S.
22	399676	Gear-Ring (Includes Mounting Parts)		394664	Piston Assy.-.030" O.S.
23	261623	** Bearing Cylinder	73	394665	Ring Set-Piston Std.
24	391086	Seal Oil		392331	Chrome Ring Set-Standard Size
25	490450	Cylinder Assembly		391781	Ring Set-Piston-.010" O.S.
26	231597	Bushing-Governor Crank (1/4" I.D.)		391782	Ring Set-Piston-.020" O.S.
27	491323	Seal-Oil		391783	Ring Set-Piston-.030" O.S.
28	93307	Retainer-E-Ring	74	260924	Lock-Piston Pin
29	93306	Cotter Hair Pin	75	299691	Pin Assembly-Piston-Standard
30	222450	Washer-Governor Crank (1/4" I.D.)		391286	Pin Assembly-Piston-.005" O.S.
31	231058	Crank-Governor (1/4" dia.)	76	490348	Rod Assembly-Connecting
32	490927	Lever Assy.-Governor (For 1/4" dia. Crank)		490469	Connecting Rod with .020" Undersize Crank Pin Bore.
33	92613	Bolt Governor Lever	77	92909	Screw-Connecting Rod
34	231082	Nut-Hex, 10-24	78	222299	Lock-Connecting Rod-Screw
35	212359	Link-Counterweight	79	89838	Wrench-Spark Plug
36	93875	Screw-Counterweight (1 )	80	66538	Elbow-Spark Plug
37	298909	.Pin Counterweight (1)	81	93723	Screw Cylinder Head (3" long).
38	399891	Counterweight Assembly	82	802592	Plug Spark (Resistor Type) (1-1/2" high)
39	491255	Decal (Label) Kit	83	491491	Head-Cylinder
40	490525	Gasket Set	84	491490	Cover-Cylinder Head
41	490815	Oil Slinger, Governor Gear and Bracket Assembly	85	261961	Guide-Exhaust Valve
42	27803	* Gasket-Valve Cover		231218	Guide-Intake Valve (Brass)
43	391406	Breather Assembly	86	210940	See Repair Manual
44	280100	Tube-Breather	87	261463	Seat-Exhaust Valve (Standard)
45	93394	Screw-Sem	88	271866	Seat-Intake Valve (Standard)
46	490327	Cap and Dipstick-Oil Filler	89	223715	* Gasket Cylinder Head
47	270920	Seal-Oil Filler Cap	90	93163	Shield-Cylinder
48	93304	Screw Clamp Mtg.	91	398808	Screw Cylinder Shield Mtg. Sem
49	223721	Clamp-Oil Filler Tube	92	492341	Wire-Ground
50	490474	Fill Group Oil	93	93381	Armature-Magneto
51	280741	Tube-Oil Filler	94	19203	Screw-Armature Mounting Sem
52	68838	Seal-Filler Tube	95	221798	Puller Flywheel
53	222698	Key Flywheel			Terminal-Ignition Cable
54	212897	Gear-Cam			
55	94305	Screw-Base Mounting Sem			
56	91084	Plug Fill Drain			

\* Included in Gasket Set—Part No. 490525  
 \*\* Requires Special tools for Installation

NOTE: All component dimensions given in U.S. inches.  
 1 inch = 25.4 mm

# REPAIR PARTS

12 HP 38" RIDING LAWN TRACTOR - - MODEL NUMBER 917.254520  
ENGINE BRIGGS AND STRATTON - MODEL NUMBER 281707, TYPE NUMBER 0412-01

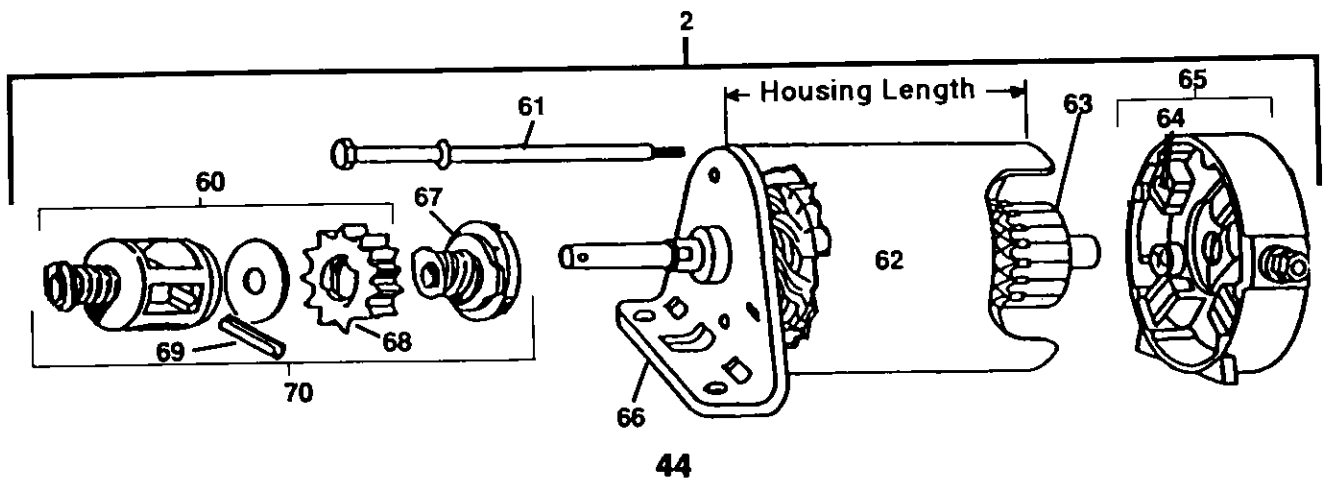
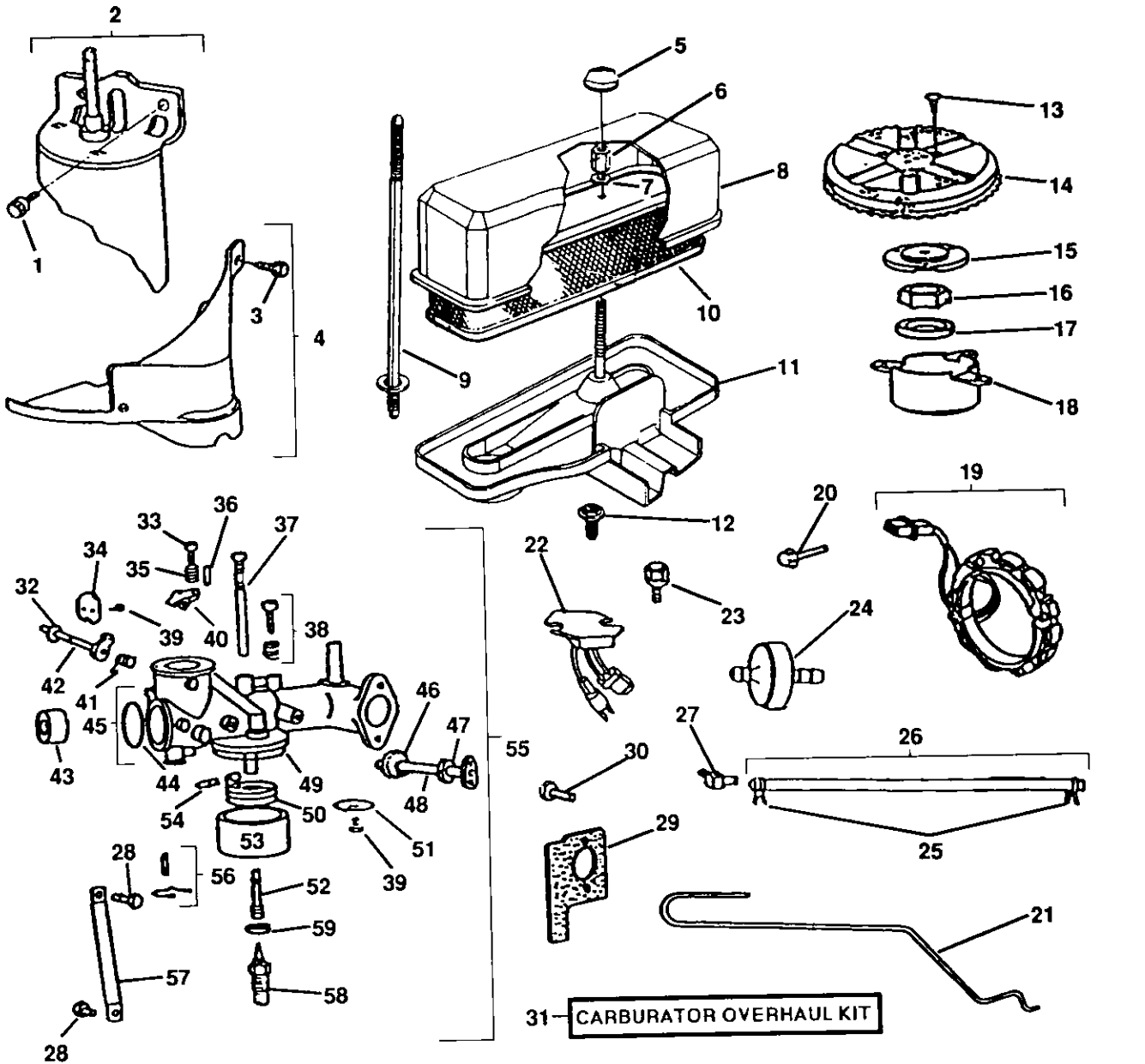

# REPAIR PARTS

12 HP 38" RIDING LAWN TRACTOR - - MODEL NUMBER 917.254520

ENGINE BRIGGS & STRATTON - MODEL NUMBER 281707, TYPE NUMBER 0412-01

KEY NO.	PART NO.	DESCRIPTION	KEY NO.	PART NO.	DESCRIPTION
1	93535	Screw-Sem	31	394698	Carburetor Overhaul Kit
2	---	Motor-Starting(12 Volt) See Chart on Bottom of Page for Replacement Parts.	32	270382	Washer-Choke Shaft
3	93984	Screw-Sem	33	91920	Screw-Machine, Fill. Hd. 8-32 x 5/8"
4	490324	Cover-Starter (Includes Mounting Screws)	34	222010	Valve-Choke
5	212706	Knob-Air Cleaner	35	26157	Spring-Throttle Adjustment
6	231532	Nut-Air Cleaner Mtg.	36	93043	Pin-Throttle Stop
7	94249	Washer-Air Cleaner	37	299740	† Nozzle-Carburetor
8	223700	Cover-Air Cleaner	38	292681	† Valve Assembly-Carburetor Idle
9	94248	Stud-Air Cleaner	39	93499	Screw-Throttle and Choke Valve Mtg. Sem
10	491519	Cartridge-Air Cleaner	40	211712	Stop-Throttle
11	491877	Body-Air Cleaner	41	261116	Spring-Choke Return
12	94018	Screw-Air Cleaner Sem	42	390684	Shaft and Lever-Choke
13	93805	Screw-Sem	43	211960	Venturi Carburetor
14	222562	Screen-Flush Rotating	44	221997	† Plug-Weich
15	280848	Spacer	45	490473	Body Assembly-Carburetor
16	92284	Nut-Hex.	46	271853	Washer-Throttle Shaft Seal (Foam)
17	220865	Washer-Spring	47	398970	Seal-Throttle Shaft
18	222561	Cup-Screen Mounting	48	491006	Shaft and Lever-Throttle
19	393295	Stator-Alternator (Tri-Circuit)	49	270511	† Gasket-Float Bowl
20	93621	Screw-Sem	50	299707	Float-Carburetor
21	261610	Link-Choke	51	222433	Valve-Throttle
22	394890	Regulator-Alternator ( 9 Amp.)	52	231323	† Screw-Nozzle
23	93559	Screw-Regulator	53	221995	Bowl-Float
24	394358	Filter-Fuel (In Fuel Line)	54	230896	† Pin-Float Hinge
25	93053	Clamp-Fuel Pipe	55	491031	Carburetor Assembly
26	393815	Line-Fuel (11" long) (Cut to Suit)	56	394681	† Valve-Fuel Inlet
27	67218	Connector-Fuel Pipe	57	222311	Bracket-Carburetor
28	93572	Screw-Carburetor	58	396568	Valve-Needle
29	270872	* Gasket-Carburetor Mounting	59	222014	† Washer-Float Bowl
30	93357	Screw-Carburetor Mtg.			

NOTE: All component dimensions given in U.S. inches.  
1 inch = 25.4 mm

Key Number		2	61	64	70	63	66	65	62
Starter Motor Mfr. and Motor Model Number		Motor and Drive Ass'y.	Thru Bolt	Brush Ass'y.	Drive Ass'y.	Armature Ass'y.	End Cap Ass'y. Drive	End Cap Ass'y. Commutator	Housing Ass'y.
Briggs & Stratton	Housing Length								
12V	3-21/32"	394805	94003	395538	490421**	390837	394857	395537*	393825

\* Includes Brush Set

\*\* Includes # 398003 Clutch Assembly (Key No. 67)  
# 280104 Gear (Key No. 68)  
# 490467 Retainer and Pin (Key No. 60)  
# 94288 Roll Pin (Key No. 69)

\* Included in Gasket Set—Part No. 490525  
† Included in Carburetor Overhaul Kit—Part No. 394698

## Attachments That Add to the Usefulness of Your Craftsman Lawn Tractor

Sears offers a wide variety of attachments that fit your tractor. Many of these are listed below with brief explanations of how they can help you. This list was current at the time of publication; however, it may change in future years — more attachments may be added, changes (including changes in the stock number) may be made in these attachments, or some may no longer be available.

Most of these attachments do not require additional hitches or conversion kits (those that do are indicated) and are designed for easy attaching and detaching. You may order these attachments at most Sears retail stores, catalog sales offices, and through the catalog.

**PERMANEX BAGGER** lets you collect grass clippings and leaves for a healthier neater-looking lawn. Two Permanex containers hold 30-gallon plastic bags. Stock number 71-24940

**LAWN SWEEPERS** let you collect grass clippings and leaves.

71-24030	30-in.	9.0 cu. ft.
71-24032	32-in.	10.0 cu. ft.
71-24033 High-Performance	32 in.	11.5 cu. ft.
71-24038	38-in.	12.5 cu. ft.

**LAWN VACS** for powerful collections of heavy grass clippings and leaves. Wand attachment to pick up debris in hard-to-reach places.

71-2452	3HP	12 bu.	71-26471 chute
---------	-----	--------	----------------

**CARTS** make hauling easy.

71-24353	4 cu. ft.	400 lb.	Dump cart
71-24354	10 cu. ft.	1,000 lb.	Hauling cart
71-24355	10 cu. ft.	1,000 lb.	Dump cart
71-24356	14 cu. ft.	1,250 lb.	Dump cart

**ROLLER** for smoother lawn surface. 36-inch wide, 18 inch diameter water-tight drum holds up to 390 lb. of weight. Rounded edges prevent harm to turf. Adjustable scraper automatically cleans drum. Stock number 71-24084.

**SPREADER/SEEDERS** make seeding, fertilizing, and weed killing easy. Broadcast spreaders are also useful for granular de-icers and sand.

71-24194 Drop type, 36 inch. 12 in. semi-pneumatic wheels. 100 lb. capacity steel hopper.

71-24394 Broadcasts over a 5 to 8 foot swath. 70 lb. capacity steel hopper. Noncorrosive spreading spinner, nylon gear box, stainless steel shaft.

71-24395 Broadcasts 8 to 10 foot swath. 160 lb. capacity. No-rust polypropylene hopper and impeller. Vinyl hopper cover.

**CORING AERATOR** takes small plugs out of soil to allow moisture and nutrients to reach grass roots. 36-inch swath. 24 hardened steel coring tips. 150 lb. capacity weight tray. Stock number 71-24351

**AERATOR** promotes deep root growth for a healthy lawn. Tapered 2.5" steel spikes mounted on 10-in. diameter discs puncture holes in soil at close intervals to let moisture soak it. Steel weight tray for increased penetration. Stock number 71-2435.

**DETHATCHER** loosens and flips thatch and matted leaves to lawn surface for easy pick up. Twenty spring tine teeth. Useful to prepare bare areas for reseeding. 40 inch rear mount: Stock number 71-24313. 38 inch front mount: Stock number 71-24301.

**SPRAYERS** use 12-volt DC electric motor that connects to the tractor battery or other 12-volt source. Includes booms for automatic spraying when pulling, and hand held wand for spot spraying. Wand has adjustable spray pattern. For applying herbicides, insecticides, fungicides, and liquid fertilizers.

71-2458 50 psi maximum pressure with 12 foot wand length. Sprays up to 25 feet with wand.

71-24398 25 psi maximum pressure with 10 foot wand length. Sprays up to 18 feet with wand.

**SNOW BLADE** for snow removal only. 14 inch high, 42 inch wide blade clears 38 inch path when angled left or right. Raises, lowers with side lever. Adjustable skids: replaceable, reversible scraper bar. (Use with tire chains, wheel weights, or rear drawbar weight). Stock number 71-24407.

**SNOWTHROWER** has 40-inch swath. Drum-type auger handles powdery and wet/heavy snow. Mounts easily with simple pin arrangement. Discharge chute adjusts to 210 degree arc from tractor seat. 6-inch diameter spout discharges snow 10 to 50 ft. Lift controlled at tractor seat. (Use with tire chains, wheel weights, or rear drawbar weight). Stock No. 71-24072.

**TIRE CHAINS** are heavy duty; closely spaced extra-large cross links give smooth ride, outstanding traction. Stock No. 71-24952.

**WHEEL WEIGHTS** for rear wheels provide needed traction for snow removal or dozing heavy materials. In pairs. Stock No. 71-24434 (30 lb. each)

**TRACTOR CAB** has heavy duty vinyl fabric over tubular steel frame, ABS plastic top; clear plastic windshield offers 360 degree visibility. Hinged metal frame doors with catch. Keeps operator warm and dry. Remove vinyl and windshield for use as sun protector in summer. Stock No. 71-24171.

Optional accessories for tractor cab: tinted/tempered solid safety glass windshield with hand operated wiper (Stock No. 71-26168); 12-volt amber caution light for mounting on cab top (Stock No. 71-26169).

**TRACTOR COVER** protects tractor from weather. Made of Evolution 3 fabric (water-repellent, extremely breathable, light weight, soft, non-abrasive, pliable in all temperatures, durable, stain-tear-puncture resistant, will not shrink or stretch). Stock No. 71-24601.