

**SEARS**

**OWNER'S  
MANUAL**

**MODEL NO.  
917.255920**

Caution: Read and  
Follow All Safety  
Rules And  
Instructions Before  
Operating This  
Equipment



**CRAFTSMAN<sup>®</sup>**  
**18.0 HP TWIN CYLINDER**  
**44" MOWER**  
**6 SPEED**  
**GARDEN TRACTOR**

- Assembly
- Operation
- Maintenance
- Service and Adjustment
- Repair Parts

# SAFETY RULES



**CAUTION: ALWAYS DISCONNECT SPARK PLUG WIRE AND PLACE WIRE WHERE IT CAN NOT CONTACT SPARK PLUG TO PREVENT ACCIDENTAL STARTING WHEN SETTING UP, TRANSPORTING, ADJUSTING OR MAKING REPAIRS.**



## IMPORTANT

**SAFETY STANDARDS REQUIRE OPERATOR PRESENCE CONTROLS TO MINIMIZE THE RISK OF INJURY. YOUR UNIT IS EQUIPPED WITH SUCH CONTROLS. DO NOT ATTEMPT TO DEFEAT THE FUNCTION OF THE OPERATOR PRESENCE CONTROLS UNDER ANY CIRCUMSTANCES.**

### TRAINING:

- Know the controls and how to stop quickly. Read this owner's manual and instructions furnished with attachments.
- Do not allow children to operate the machine. Do not allow adults to operate it without proper instruction.
- Do not carry passengers. Do not mow when children and others are around.
- Do not attempt to operate your vehicle or mower when not in the driver's seat.
- Always get on or off your vehicle from the operator's left hand side.
- The vehicle and attachments should be stopped and inspected for damage after striking a foreign object, and the damage should be repaired before restarting and operating the equipment.

### PREPARATION:

- Always wear substantial footwear. Do not wear loose fitting clothing that could get caught in moving parts.
- Clear the work area of objects (wire, rocks, etc.) which might be picked up and thrown.
- Disengage all attachment clutches before attempting to start the engine.
- Handle gasoline with care – it is highly flammable.
  - Use approved gasoline containers.
  - Never remove the fuel cap of the fuel tank or add gasoline to a running or hot engine or an engine that has not been allowed to cool for several minutes after running. Never fill tank indoors. Always clean up spilled gasoline.
  - Open doors if the engine is run in the garage – exhaust fumes are dangerous. Do not run the engine indoors.
- Do not operate the mower without the entire grass catcher, on mowers so equipped, or the deflector shield in place.

### OPERATION:

- Keep your eyes and mind on your vehicle, mower, and the area being cut. Do not let other interests distract you.
- Disengage power to attachments and stop the engine before leaving the operator's position.
- Disengage power to mower, stop the engine, and disconnect spark plug wire(s) from spark plug(s) before cleaning, making an adjustment, or repair. Be careful to avoid touching hot muffler or engine components.
- Disengage power to attachments when transporting or not in use.
- Take all possible precautions when leaving the vehicle unattended. Disengage the power take-off, lower the attachments, shift into neutral, set the parking brake, stop the engine, and remove the key.
- Do not stop or start suddenly when going uphill or downhill. Mow up and down the face of slopes (not greater than 15°), never across the face.
- Reduce speed on slopes and make turns gradually to prevent tipping or loss of control. Exercise extreme caution when changing direction on slopes.
- While going up or down slopes, place gearshift control lever in 1st gear position to negotiate the slope without stopping.

- Never mow in wet or slippery grass, when traction is unsure, or at a speed which could cause a skid.
- Stay alert for holes in the terrain and other hidden hazards. Keep away from drop-offs.
- Do not drive too close to creeks, ditches, and public highways.
- Exercise special care when mowing around fixed objects in order to prevent the blades from striking them. Never deliberately run vehicle or mower into or over any foreign objects.
- Never shift gears until vehicle comes to a stop.
- Never place hands or feet under the mower, in discharge chute, or near any moving parts while vehicle or mower is running. Always keep clear of discharge chute.
- Use care when pulling loads or using heavy equipment.
  - Use only approved drawbar hitch points.
  - Limit loads to those you can safely control.
  - Do not turn sharply. Use care when backing.
  - Use counterweight or wheel weights when suggested in owner's manual.
- Watch out for traffic when crossing or near roadways.
- When using any attachments, never direct discharge of material toward bystanders nor allow anyone near the vehicle while in operation.
- Except for adjustments, do not operate engine if air cleaner or cover directly over carburetor air intake is removed. Removal of such part could create a fire hazard.
- Do not change the engine governor settings or overspeed the engine; severe damage or injury may result.
- When using the vehicle with mower, proceed as follows:
  - Mow only in daylight or in good artificial light.
  - Shut the engine off when unclogging chute.
  - Check the blade mounting bolts for proper tightness at frequent intervals.
- Disengage power to mower before backing up. Do not mow in reverse unless absolutely necessary and then only after careful observation of the entire area behind the mower.
- Keep the vehicle and attachments in good operating condition, and keep safety devices in place and working.

### MAINTENANCE AND STORAGE

- Keep all nuts, bolts, and screws tight to be sure the equipment is in safe working condition.
- Never store the equipment with gasoline in the tank inside a building where fumes may reach an open flame or spark. Allow the engine to cool before storing in any enclosure.
- To reduce fire hazard, keep the engine free of grass, leaves, or excessive grease. Do not clean product while engine is running.
- Do not operate without a muffler, or tamper with exhaust system. Damaged mufflers or spark arresters could create a fire hazard. Inspect periodically and replace if necessary.
- Under normal usage the grass catcher bag material is subject to deterioration and wear. It should be checked frequently for bag replacement. Replacement bags should be checked to ensure compliance with the original manufacturer's recommendations or specifications.



**LOOK FOR THIS SYMBOL TO POINT OUT IMPORTANT SAFETY PRECAUTIONS. IT MEANS – ATTENTION!!! BECOME ALERT!!! YOUR SAFETY IS INVOLVED.**

# 18 HP 44" RIDING GARDEN TRACTOR -- MODEL NUMBER 917.255920

## SCHEMATIC

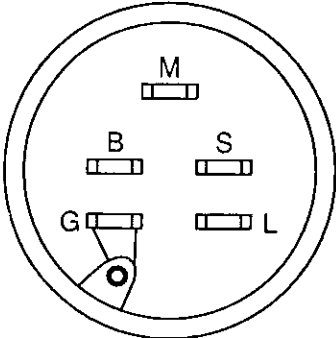
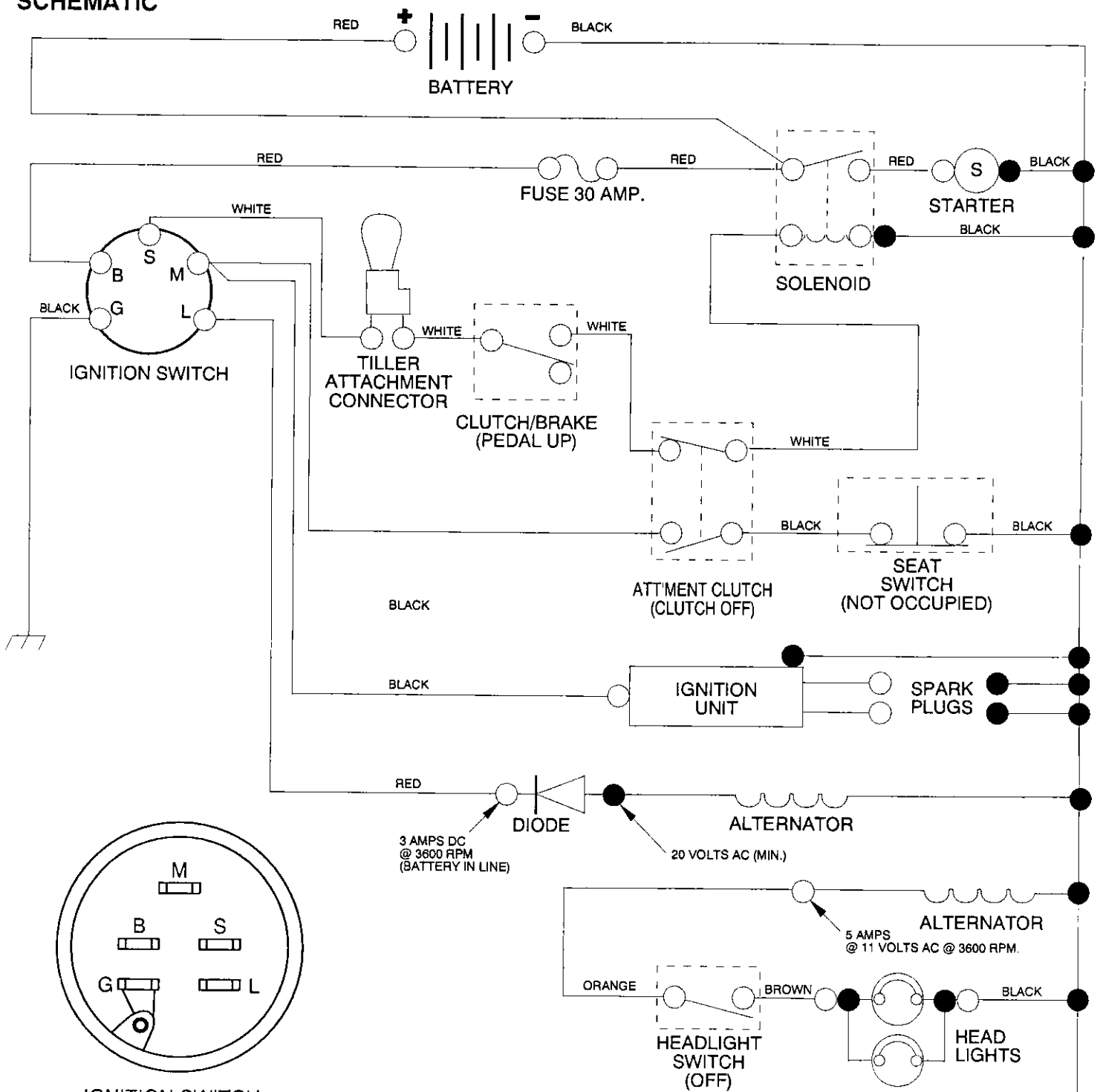

IGNITION SWITCH

POSITION	CIRCUIT
OFF	M + G
ON	B + L
START	B + S

- NON-REMOVABLE CONNECTIONS
- REMOVABLE CONNECTIONS

### WIRING INSULATED CLIPS

NOTE: IF WIRING INSULATED CLIPS WERE REMOVED FOR SERVICING OF UNIT, THEY SHOULD BE REPLACED TO PROPERLY SECURE YOUR WIRING

### NOTE

YOUR TRACTOR IS EQUIPPED WITH A SPECIAL ALTERNATOR SYSTEM. THE LIGHTS ARE NOT CONNECTED TO THE BATTERY, BUT HAVE THEIR OWN ELECTRICAL SOURCE. BECAUSE OF THIS, THE BRIGHTNESS OF THE LIGHTS WILL CHANGE WITH ENGINE SPEED. AT IDLE THE LIGHTS WILL DIM. AS THE ENGINE IS SPEEDED UP, THE LIGHTS WILL BECOME THEIR BRIGHTEST.

# REPAIR PARTS

18 HP 44" RIDING GARDEN TRACTOR -- MODEL NUMBER 917.255920

## ELECTRICAL

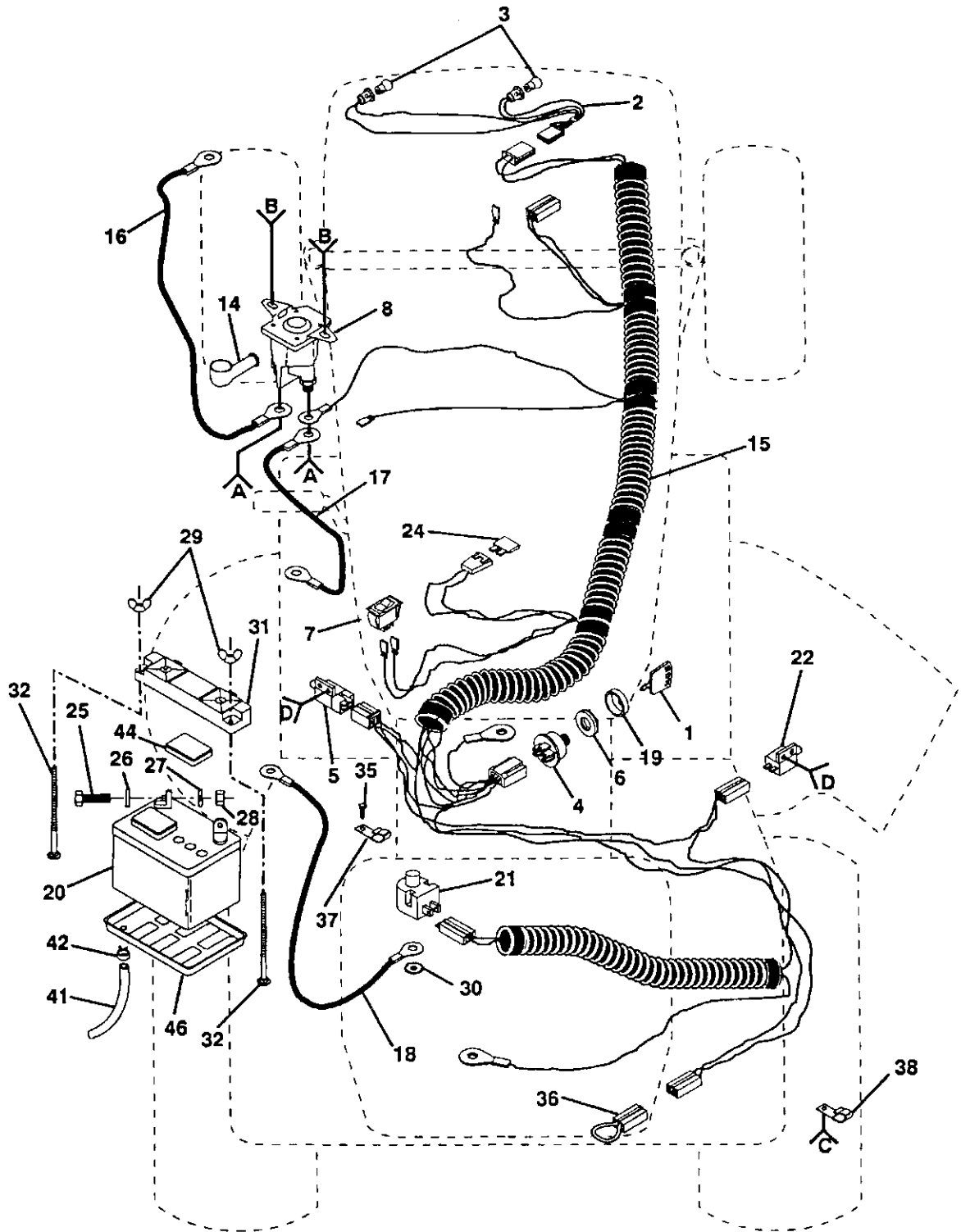

# REPAIR PARTS

## 18 HP 44" RIDING GARDEN TRACTOR - - MODEL NUMBER 917.255920

### ELECTRICAL

KEY NO.	PART NO.	DESCRIPTION	KEY NO.	PART NO.	DESCRIPTION
1	109310X	Molded Key	23	17021008	Screw, Hex Tap. #10-24 x 1/2
2	110859X	Harness Light Socket	24	108824X	Fuse
3	4152J	Bulb, Light	25	74760412	* Bolt, Hex 1/4-20 x 3/4
4	4406R	Switch, Ignition	26	STD551025	* Washer 9/32 x 5/8 x 16 Ga.
5	109553X	Switch, Interlock Attachment Clutch	27	STD551125	* Washer, Lock 1/4
6	109788X	Ignition, Nut	28	STD541025	* Nut, Hex 1/4-20
7	110712X	Switch, Light	29	123198X	Nut, Wing 1/4-20
8	109081X	Solenoid	30	11050600	Washer, Lock 3/4 Ext. Tooth
9	10090400	Washer, Lock 1/4	31	102476X	Guard, Terminal
10	73350400	* Nut, Jam 1/4-20	32	72240460	Bolt, Carriage 1/4-20 x 7-1/2
11	74780408	Bolt, Fin Hex 1/4-20 UNC x 1/2	35	74760612	Bolt, Fin Hex 3/8-16 UNC x 3/4
12	11050400	Washer, Lock Ext. Tooth 1/4	36	102501X	Wire Loop
13	73510400	Nut, Keps 1/4-20	37	2751R	Clip, Fuel Line
14	719J	Cover, Terminal	38	235R	Clip, Insulation
15	121802X	Harness, Ignition	39	74780408	* Bolt, Hex 1/4-20 x 1/2
16	4799J	Cable, Battery	40	73680400	Nut, Crownlock 1/4-20
17	4206J	Cable, Battery	41	100541K	Tube
18	4207J	Cable, Ground	42	109596X	Clamp, Hose
19	109787X	Bezel, Ignition	44	121264X	Caps, Battery
20	121537X	Battery	46	7603J	Tray, Battery
21	121305X	Switch, Seat	—	101539X	Sheet Instruction, Tractor 15"
22	104445X	Switch, Interlock-Clutch			

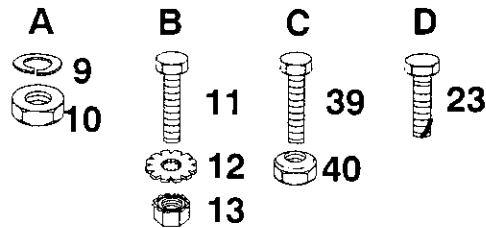

# REPAIR PARTS

18 HP 44" RIDING GARDEN TRACTOR -- MODEL NUMBER 917.255920

## CHASSIS AND ENCLOSURES

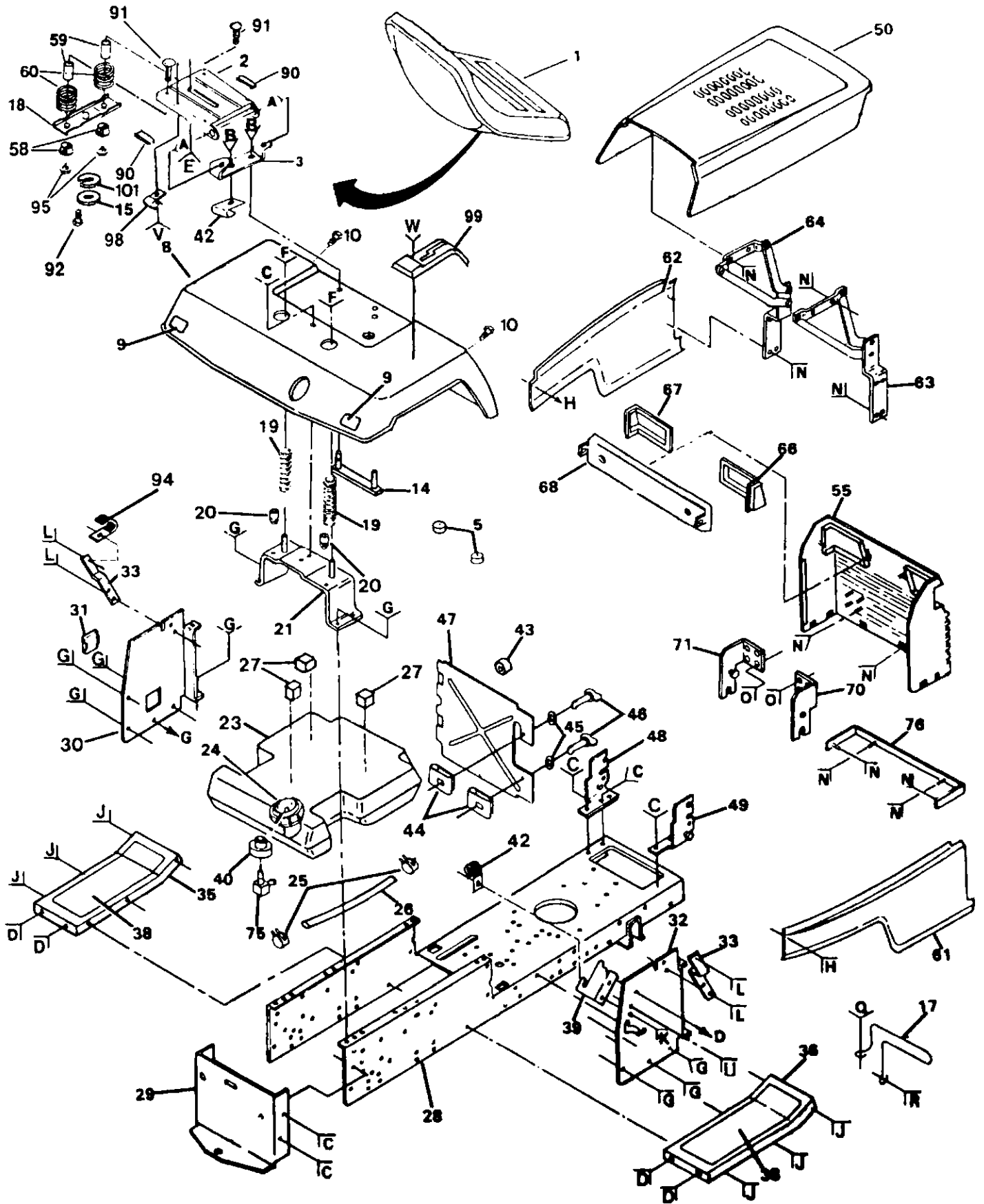

# REPAIR PARTS

## 18 HP 44" RIDING GARDEN TRACTOR - - MODEL NUMBER 917.255920

### CHASSIS AND ENCLOSURES

KEY NO.	PART NO.	DESCRIPTION	KEY NO.	PART NO.	DESCRIPTION
1	127437X	Seat	60	121250X	Spring, Compression
2	124294X	Pan, Seat	61	108403X417	Panel, Side, R.H.
3	126656X	Bracket, Pivot, Seat	62	108410X417	Panel, Side, L.H.
4	105529X	Bolt, Shoulder 5/16-18	63	106091X	Hinge, R.H.
5	124238X	Cap, Spring	64	106090X	Hinge, L. H.
6	STD541431	* Locknut 5/16-18	66	106003X	Lens, R.H.
7	STD541437	* Locknut 3/8-16	67	106004X	Lens, L.H.
8	123784X417	Fender	68	110897X	Bezel, Headlight
9	106202X	Reflector, Rear	70	108512X	Bracket, Pivot, R.H.
10	17490608	Screw, Hex Washer Thd. Roll 3/8-16 x 1/2	71	108513X	Bracket, Pivot, L.H.
11	17490612	Screw, Hex Washer Thd. Roll 3/8-16 x 3/4	75	8710J	Stem, Tank, Fuel
12	19131312	Washer 13/32 x 13/16 x 12 Ga.	76	110350X417	Strap Assembly, Grill
13	STD523707	* Bolt, Hex, 3/8-16 x 3/4	79	11050600	Washer, Lock, Ext. Tooth 3/8
14	105511X	Strap, Fender	83	17490616	Bolt, Hex Washer Thread Rolling 3/8-16 x 1
15	19171912	Washer 17/32 x 1-3/16 x 12 Ga	84	19131616	Washer, 13/32 x 1 x 16 Ga.
17	108885X	Guard, Muffler	85	19131614	Washer, 13/32 x 1 x 14 Ga.
18	121246X	Bracket, Switch, Seat	86	19060718	Washer, 3/16 x 7/16 x 18 Ga.
19	124181X	Compression, Spring	87	106909X	Screw, Special
20	105531X	Nut, Push	88	106910X	Washer
21	105509X	Bracket, Fender	89	108402X	U-Clip
23	106020X	Tank, Fuel	90	121251X	Strip, Foam
24	123549X	Cap, fuel	91	72170410	Bolt, Carr. 1/4-20 x 1, 1/4
25	123487X	Clamp, Hose	92	74780814	Bolt, Fin Hex 1/2-13 x 7/8 GR.5
26	5277J	Line, Fuel	93	127018X	Bolt, Shoulder 5/16-18 x .62
27	106082X	Pad, Spacer	94	5320R	Clip, Insulated
28	127166X	Chassis Assembly	95	123976X	Nut, Hex Large Flange
29	123785X	Drawbar	96	STD511005	* Screw, Slt'd. Pan Head #10-24 x 1/4
30	124118X	Panel, Dash, L.H.	97	73951000	Nut, Keps #10-24
31	121794X	Cover, Access	98	4171R	Clip, Insulated
32	110828X	Panel, Dash, R. H.	99	123825X	Console, Shifter
33	105525X	Bracket, Support, Dash	100	STD523710	* Bolt, Fin Hex 3/8-16 UNC x 1
35	105465X417	Footrest, L.H.	101	STD551150	* Washer, Lock 1/4
36	105464X417	Footrest, R.H.	102	10100800	Washer, Lock
37	STD533707	* Bolt, Carr. 3/8-16 x 3/4	103	74640806	Screw #8 x 3/8
38	105466X	Pad, Footrest	104	120579X	Nut, Pal
39	110923X	Bracket, Clutch, Mower	—	105806X	Decal, Grill
40	3645J	Bushing	—	105568X	Decal, Stripe (Grill)
42	2751R	Clip, Insulated	—	4900J	Decal, Clutch/Brake (Footrest)
43	110436X	Grommet, Split	—	109199X	Decal, Drive Belt
44	105839X	Receptacle	—	105801X	Decal, Fender
45	105838X	Retainer	—	105567X	Decal, Speed, Deck Size (Chassis)
46	123650X	Stud, 1/4 Turn	—	106813X	Decal, Stripe (L.H. Side Panel)
47	105867X	Shield, Heat	—	106814X	Decal, Stripe (R.H. Side Panel)
48	109015X	Bracket, Pivot, L. H.	—	106974X	Decal, Caution
49	109016X	Bracket, Pivot, R. H.	—	108744X	Decal, Hood
50	106013X417	Hood	—	128259	Decal, Grill
54	108067X	Nut, Pal	—	127521	Decal, U.S.A.
55	105528X	Grill	—	130595	Decal, Hood R.H.
58	121248X	Bushing, Snap	—	130596	Decal, Hood L.H.
59	121249X	Spacer, Split			

\* STANDARD HARDWARE — PURCHASE LOCALLY

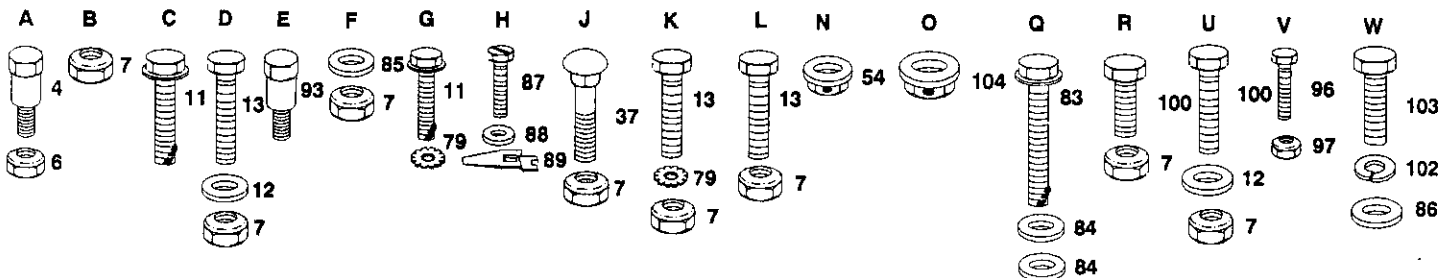

# REPAIR PARTS

18 HP 44" RIDING GARDEN TRACTOR - - MODEL NUMBER 917.255920

DRIVE

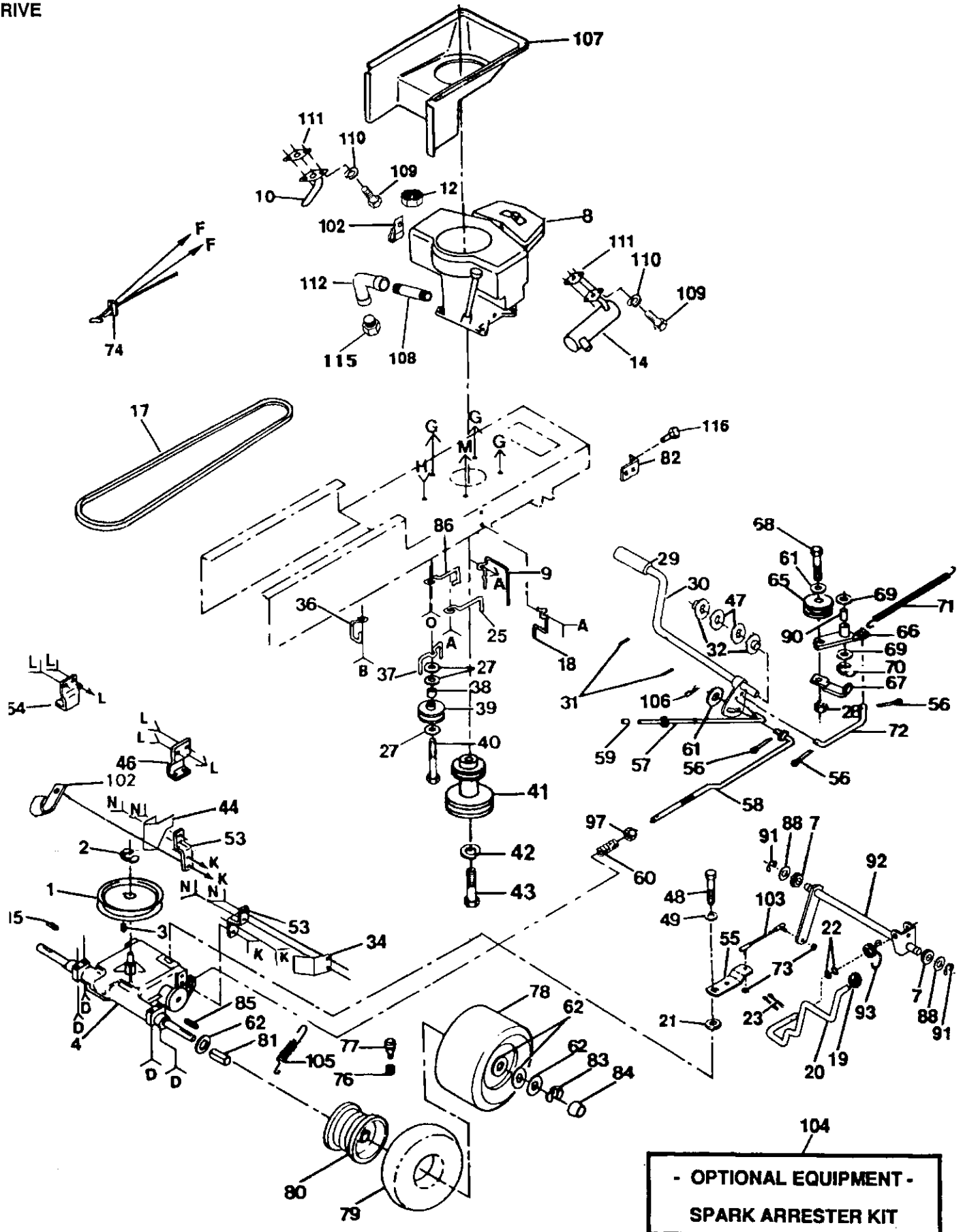



# REPAIR PARTS

## 18 HP 44" RIDING GARDEN TRACTOR - - MODEL NUMBER 917.255920

### DRIVE

KEY NO.	PART NO.	DESCRIPTION	KEY NO.	PART NO.	DESCRIPTION
1	121327X	Pulley, Transaxle (Driven)	62	123800X	Washer 1-1/32 x 1-5/8 x 16
2	12000004	Ring, Retainer	65	123766X	Pulley, Idler
3	2228M	Key, Woodruff #9	66	123789X	Arm, Idler
4	123797X	Transaxle, 6-Speed, Peerless Model No. 143.820-016	67	123205X	Retainer, Belt
6	19111214	Washer 11/32 x 3/4 x 14 Ga.	68	STD523715	* Bolt, Hex 3/8-16 X 1-1/2
7	71208	Bushing, Rod, Steering	69	110812X	Washer, Hardened
8	110928X	Engine, Briggs & Stratton 18 HP Model No. 422707, Type 1211-01	70	12000039	Ring, Clip
9	121440X	Guide, Belt Lower Engine	71	105709X	Spring, Return, Clutch
10	100229L	Tube Assembly, Exhaust	72	105710X	Link, Clutch
12	STD541437	* Nut, Keps 3/8-16	73	73530400	Nut 1/4-28
14	108373X	Muffler	74	124559X	Control, Throttle
17	123796X	V-Belt, Drive	75	17720410	Screw, Hex, Thread Cutting 1/4-20 x 5/8
18	121441X	Guide, Belt Lower Engine	76	59192	Cap, Valve
19	106933X	Knob	77	65139	Stem, Valve
20	123781X	Rod, Shifter	78	124632X	Tire, Rear
21	105701X	Washer, Shift Plate	79	7152J	Tube
22	19171216	Washer 17/32 x 3/4 x 16 Ga.	80	106108X361	Rim
23	STD561210	* Pin, Cotter 1/8 x 1	81	108097X	Spacer, Split
24	17490612	Screw, Hex Washer Hd.Thd. Roll. 3/8-16 x 3/4	82	108236X	Bracket, Switch
25	105730X	Keeper, Belt, Engine	83	12000053	E-Ring
26	STD523710	* Bolt, Hex 3/8-16 x 1	84	104757X	Cap Hub, Rear
27	19131312	Washer 13/32 x 13/16 x 12 Ga.	85	9396E	Key Square 1/4 x 2
28	73680600	* Nut, Crownlock 3/8-16	86	121218X	Keeper, Belt, Engine
29	8883R	Cover, Foot Pedal	87	17490624	Bolt, Hex, Washer, Thread Rolling 3/8-16 x 1-1/2
30	122424X	Shaft, Foot Pedal	88	19212016	Washer 21/32 x 1-1/4 x 16 Ga.
31	1572H	Pin, Roll 3/16 x 1	89	STD523707	* Bolt Hex 3/8-16 x 3/4
32	STD551062	* Washer 21/32 x 1 x 16 Ga.	90	105706X	Bearing
34	123792X	Keeper, Belt, Transaxle, R.H.	91	12000008	Ring, Klip
36	123788X	Retainer, Belt	92	123772X	Shaft Assembly, Shifter
37	109070X	Keeper, Belt	93	123782X	Spring, Torsion
38	4470J	Spacer	94	STD551237	* Washer, Lock, Ext. Tooth 3/8
39	123674X	Idler, Flat	97	STD541437	* Locknut 3/8-16
40	STD523727	* Bolt, Hex 3/8-16 x 2-3/4	101	17490512	Screw, Hex, Washer Thd. Rolling 5/16-18 x 3/4
41	127958	Pulley, Engine	102	2751R	Clip, Fuel Line
42	10040700	Washer, Lock	103	123793X	Rod, Tie
43	74770720	Bolt, Hex 7/16-20 x 1-1/4	104	674A380	Spark Arrester Kit
44	123791X	Keeper, Belt, Transaxle, L.H.	105	110422X	Spring, Brake Return
46	123776X	Bracket Transaxle, RH.	106	4497H	Clip, Hair Pin
47	120183X	Bearing Nylon	107	105953X	Duct, Air Intake
48	71040412	* Bolt, Hex 1/4-28 x 3/4	108	13280336	Nipple, Pipe
49	STD551025	* Washer 9/32 x 3/4 x 16 Ga.	109	STD522507	* Bolt, Hex 1/4-20 x 3/4
51	STD541431	* Locknut 5/16-18	110	STD551125	* Washer, Lock 1/4
52	74780544	* Bolt, Hex 5/16-18 x 2-3/4	111	8545J	Gasket
53	123787X	Strap, Torque	112	13200300	Elbow, Pipe STD 90°
54	123780X	Bracket, Transaxle, L.H.	113	74760516	Bolt, Hex 5/16-18 UNC x 1
55	123794X	Shift Arm	114	19111212	* Washer 11/32 x 3/4 x 12 Ga.
56	STD561210	* Pin, Cotter 1/8 x 3/4	115	-----	Plug, Oil (Order from Mfg.)
57	125637X	Rod, Brake, Park	116	STD601005	* Screw, Tap Hex Hd. #10-24 x 1/2
58	123786X	Rod, Brake	—	124607X	Decal, Engine Briggs & Stratton
59	124236X	Cap, Plunger			
60	126909X	Spring, Rod, Brake			
61	STD551037	* Washer 13/32 x 13/16 x 16 Ga.			

\* STANDARD HARDWARE — PURCHASE LOCALLY

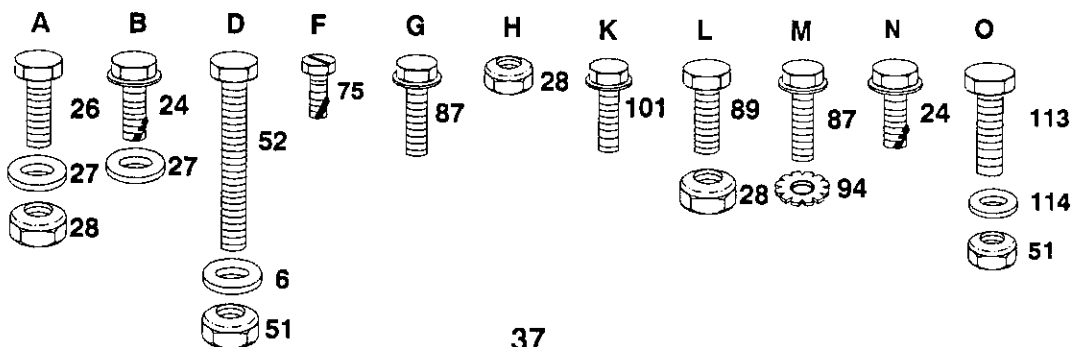

# REPAIR PARTS

18 HP 44" RIDING GARDEN TRACTOR - - MODEL NUMBER 917.255920

## STEERING

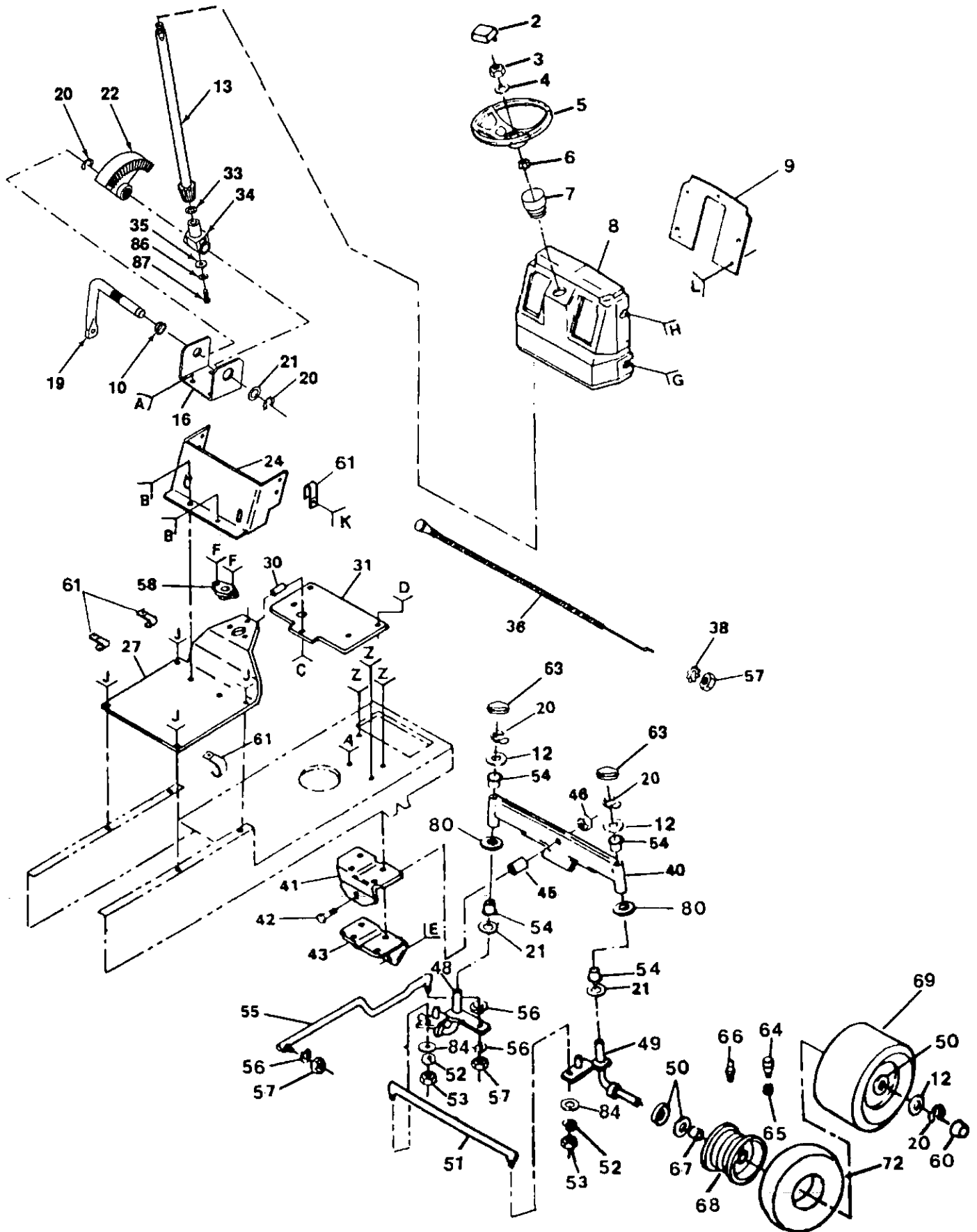

# REPAIR PARTS

## 18 HP 44" RIDING GARDEN TRACTOR - - MODEL NUMBER 917.255920

### STEERING

KEY NO.	PART NO.	DESCRIPTION	KEY NO.	PART NO.	DESCRIPTION
2	100710L	Insert, Steering Wheel	46	73601000	Locknut, Hex W/washer 5/8-16
3	73940800	* Nut, Top Lock 1/2-20 UNF	47	17490508	Screw, Hex Washer Thd. Rolling 5/16-18 x 1/2
4	100712K	Washer	48	105656X	Spindle, L.H.
5	100713N	Wheel, Steering	49	105654X	Spindle, R.H.
6	100711L	* Adapter-Steering Wheel	50	121749X	Washer 25/32 x 1-1/4 x 16 Ga.
7	106015X	Sleeve-Steering	51	121321X	Rod, Tie
8	120028X	Dash	52	STD551131	* Washer, Lock 5/16
9	129621	Plate, Dash	53	STD541131	* Nut, Hex 5/16-24
10	109816X	Nyliner, Snap-In	54	3366R	Bearing
11	17490608	Screw, Hex Washer Thd. Rolling 3/8-16-1/2	55	128122	Link, Drag
12	121748X	Washer 25/32 x 1-5/8 x 16 Ga.	56	STD551137	* Washer, Lock 3/8
13	128755	Shaft, Steering	57	STD541137	* Nut, Hex 3/8-24
16	124036X	Bracket, Steering	58	1554J	Bushing, Steering
18	17490612	Screw, Hex Washer Thd. Rolling 3/8-16 x 3/4	59	17431008	Screw, Hex #10-16 x 1/2
19	124033X	Shaft, Pitman	60	104757X	Cap, Hub, Front
20	12000029	Ring, Klip	61	2751R	Clip, Fuel Line
21	6266H	Bearing, Thrust	62	STD541037	* Nut, Hex 3/8-16
22	124034X	Gear, Sector	63	121232X	Spindle, Cap
24	105518X	Dash, Lower	64	59192	Cap, Valve
25	74180512	Screw, Crown Truss Hd. 5/16-18 x 3/4	65	65139	Stem, Valve
26	STD541431	* Locknut 5/16-18	66	278H	Fitting, Grease
27	123783X	Saddle	67	9040H	Bearing
28	STD541437	* Locknut 3/8-16	68	106732X361	Rim, Front
29	STD523120	* Bolt, Hex 5/16-18 x 2	69	106222X	Tire, Front
30	121236X	Spacer	72	59904	Tube, Tire, Front
31	1282231	Support Plate, Battery	73	72110622	Bolt, Carriage Hex 3/8-16 x 2-3/4
32	STD523707	* Bolt, Hex 3/8-16 x 3/4	74	121235X	Spacer
33	57079	Washer	75	19131416	Washer 13/32 x 7/8 x 16 Ga.
34	124035X	Shaft, Support	77	STD512507	* Screw, Pan Head 1/4-20 x 3/4
35	126684X	Washer 5/8 x 1/4 x 16 Ga.	78	19091216	Washer 13/32 x 3/4 x 16 Ga.
36	121525X	Control, Choke	79	73510400	Nut, Keps 1/4 NC
38	STD551237	* Washer, Lock, Int./Ext. Tooth 3/8	80	19272016	Washer 27/32 x 1-1/4 x 16 Ga
39	72110608	Bolt, Carriage	82	122819X	Screw, Special 3/8-16 x 3/4
40	108075X	Axle, Front	84	19111216	Washer 11/32 x 3/4 x 16 Ga.
41	105663X	Support, Saddle, Rear	86	STD551125	* Washer, Lock 1/4
42	74761060	Bolt, Hex 5/8-11 x 3-3/4	87	71070410	Screw, Socket Hex 1/4 x 20 x 5/8
43	105664X	Support, Saddle, Front	—	105810X	Decal-Cap, Steering Wheel
45	110438X	Spacer Bearing, Front Axle	—	108456X	Decal, Operating Instructions(Dash)

\* STANDARD HARDWARE — PURCHASE LOCALLY

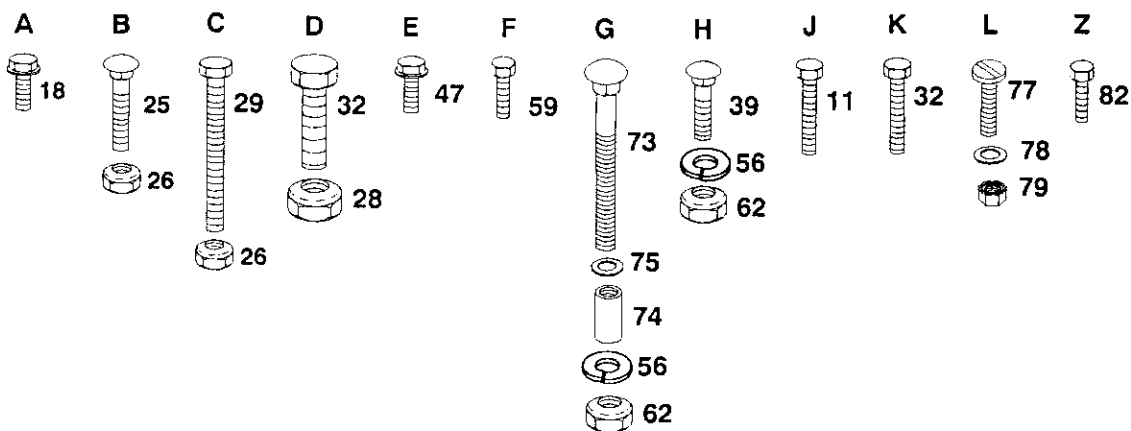

# REPAIR PARTS

18 HP 44" RIDING GARDEN TRACTOR -- MODEL NUMBER 917.255920

## LIFT ADJUSTMENT

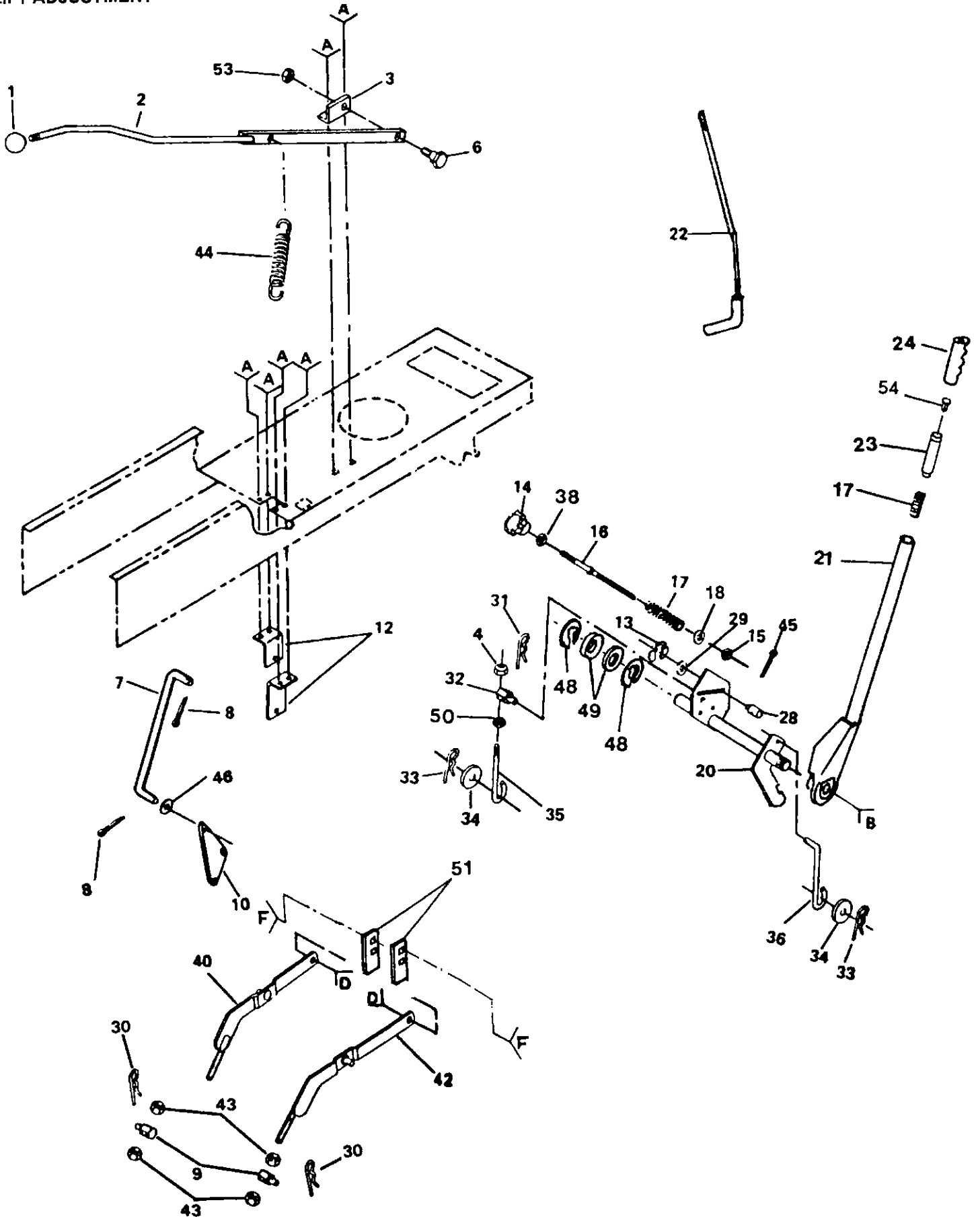

# REPAIR PARTS

18 HP 44" RIDING GARDEN TRACTOR -- MODEL NUMBER 917.255920

## LIFT ADJUSTMENT

KEY NO.	PART NO.	DESCRIPTION	KEY NO.	PART NO.	DESCRIPTION
1	106933X	Knob	30	9135R	Clip, Retainer
2	110924X	Lever, Mower Clutch	31	4939M	Spring, Retainer
3	106498X	Bracket, Pivot	32	110447X	Trunnion, Lift
4	73710700	Nut, Jam 7/16-20 UNF	33	4921H	Retainer Spring
5	STD523707	* Bolt, Hex 3/8-16 x 3/4	34	19171516	Washer 17/32 x 15/16 x 16 Ga.
6	106451X	Bolt, Shoulder	35	110448X	Link, Lift Adjust
7	108387X	Rod, Clutch, Primary	36	110029X	Link, Lift
8	76020412	Pin, Cotter 1/8 x 3/4	38	STD541237	* Nut-Jam 3/8-16
9	106308X	Trunnion, Lift Lower	40	121599X	Arm, Suspension. L.H.
10	109728X	Bellcrank	41	105848X	Bolt, Shoulder 3/8-16
12	106444X	Bracket, Bellcrank	42	121598X	Arm, Suspension, R.H.
13	12000037	Ring, Klip	43	STD541050	* Nut, Hex Fin. 1/2-13
14	100734K	Knob, Height Adjustment	44	58606	Spring
15	110807X	Nut, Special	45	76020308	Pin, Cotter 3/32 x 1/2
16	110729X	Rod, Adjust, Lift	46	19131410	Washer 13/32 x 7/8 x 10 Ga.
17	2876H	Spring	47	73980600	Locknut 3/8-16
18	19131016	Washer 13/32 x 5/8 x 16 Ga	48	12000022	E-Ring
20	121000X	Shaft, Lift	49	19292016	Washer 29/32 x 1-1/4 x 16 Ga
21	121002X	Lever, Lift (Incl. Key No. 22)	50	73360700	Nut 7/16-20 UNF
22	121006X	Rod, Lever	51	121252X	Upstop, Mower
23	122364X	Plunger, Lever	52	72140608	Bolt, Carriage 3/8-16 x 1
24	109413X	Grip, Handle	53	73680600	Locknut 3/8-16
25	STD523715	* Bolt, 3/8-16 x 1-1/2	54	122365X	Button, Plunger
27	110739X	Washer, Spring 3/8			
28	110810X	Trunnion, Stop Depth			
29	19151216	Washer 15/32 x 3/4 x 16 Ga.			

\* STANDARD HARDWARE — PURCHASE LOCALLY

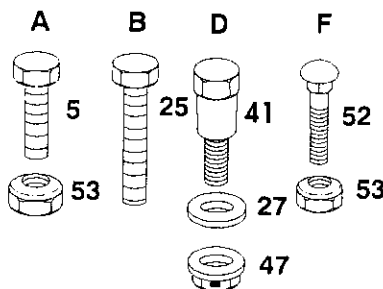

**REPAIR PARTS**

**18 HP 44" RIDING GARDEN TRACTOR - - MODEL NUMBER 917.255920**

**MOWER**

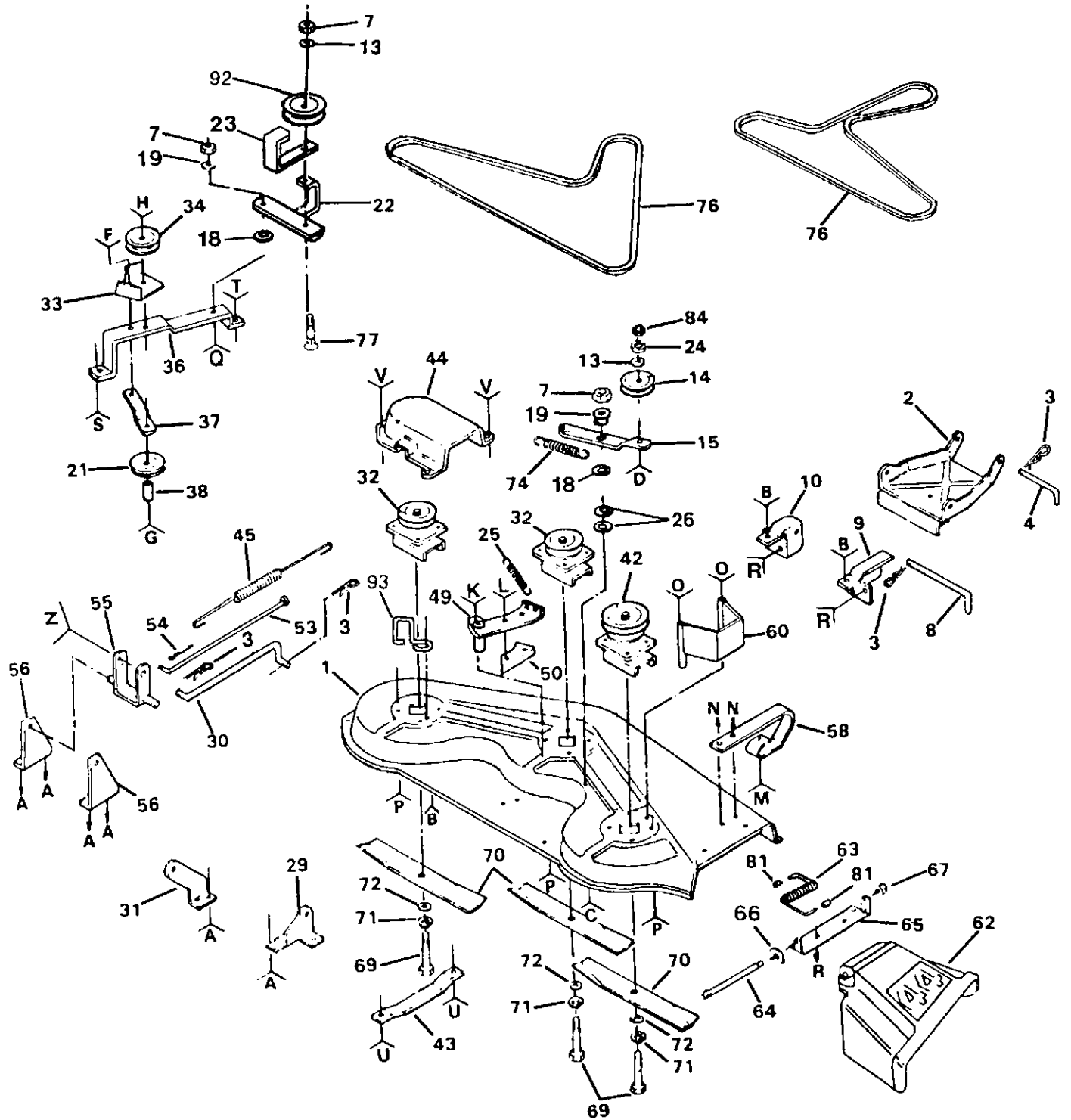

# REPAIR PARTS

## 18 HP 44" RIDING GARDEN TRACTOR - - MODEL NUMBER 917.255920

### MOWER

KEY NO.	PART NO.	DESCRIPTION	KEY NO.	PART NO.	DESCRIPTION
1	121423X	Housing, Mower	51	STD551031	* Washer 11/32 x 11/16 x 16 Ga.
2	129762	Stop Assembly, Link, Parallel	52	STD523112	* Bolt, Hex 5/16-18 x 1-1/4
3	4921H	Retainer, Spring	53	108394X	Rod, Brake
4	105744X	Pin, Front Hinge	54	STD560907	* Pin, Cotter 3/32 x 3/4
7	73680600	Locknut 3/8 -16	55	110384X	Shaft, Rock
8	109835X	Pin, Rear Hinge	56	108393X	Support, Shaft Rock
9	106512X	Bracket, Lift R. H.	58	8418J	Runner, R.H.
10	106511X	Bracket, Lift L. H.	60	102924X	Guard, Belt-R.H.
11	STD533107	* Bolt, Carriage 5/16-18 x 3/4	61	74760580	Bolt, Hex 5/16-18 x 5
12	73680500	Locknut 5/16-18	62	109785X	Shield, Deflector
13	19131614	Washer 13/32 x 1 x 14 Ga.	63	106734X	Spring
14	102932X	Idler, Flat	64	106735X	Rod, Hinge
15	106526X	Arm, Idler Deck	65	109743X	Bracket, Deflector
16	74110632	Screw, Flat Hd. 3/8-16 x 2	66	19111016	Washer 11/32 x 5/8 x 16 Ga.
17	STD523712	* Bolt, Hex 3/8-16 x 1-1/4	67	110452X	Nut, Push
18	106513X	Washer, Wear	68	STD533707	* Bolt, Carriage 3/8-16 x 3/4
19	106902X	Spacer	69	STD623715	* Bolt, Hex 3/8-24 x 1-1/2 Gr. 5
20	72110505	Bolt, Carriage 5/16-18 x 5/8	70	106635X	Blade
21	102403X	Pulley, Idler	71	STD551137	* Washer, Lock 3/8
22	121424X	Arm, Idler	72	19132012	Washer 13/32 x 1-1/4 x 12 Ga.
23	121426X	Guide, Belt	73	17490612	Screw, Hex Washer Thd. Rolling 3/8- 16 x 3/4
24	72110506	Bolt, Carriage 5/16-18 x 3/4	74	7644J	Spring, Extension
25	106530X	Spring	75	72140612	Bolt, Carriage 3/8-16 x 1-1/2
26	19111216	Washer 11/32 x 3/4 x 16 Ga.	76	106085X	V-Belt
27	1685H	Locknut 5/16-18	77	72140616	Bolt, Carriage 3/8-16 x 2
29	123807X	Bracket, Suspension Rear R.H.	81	105304X	Cap, Sleeve
30	108235X	Rod, Clutch	82	STD523710	* Bolt, Hex 3/8-16 x 1
31	123808X	Bracket, Suspension Rear L.H.	84	STD541037	* Nut, Hex 3/8-16
32	121622X	Mandrel, Secondary	85	STD541031	* Nut, Hex 5/16- 18
33	106529X	Guide, Belt	86	STD551131	* Washer, Lock 5/16
34	677A451	Pulley, Idler	89	74760412	Bolt, Hex 1/4-20 x 3/4
36	106523X	Bar, Support Idler	90	19091616	Washer 9/32 x 1 x 16 Ga.
37	106522X	Brace, Idler Deck	91	73680400	Locknut 1/4-20
38	121236X	Spacer	92	121316X	Pully, Idler
40	STD523730	* Bolt, Hex 3/8-16 x 3	93	121352X	Keeper, Belt
41	STD533710	* Bolt, Carriage 3/8-16 x 1	94	19131316	Washer 13/32 x 13/16 x 16 Ga.
42	121704X	Mandrel, Primary	95	19131410	Washer 13/32 x 7/8 x 10 Ga.
43	7631J	Runner, L.H.	—	121343X	Decal, Danger Warning
44	106214X	Guard	—	106223X	Decal, V-Belt Drive Schematic
45	121427X	Spring, Extension	—	121825X	Replacement Mower Deck
46	121827X	Bolt, Shoulder			
47	73930600	Nut, Centerlock 3/8-16			
49	106606X	Arm, Brake			
50	102951X	Brake, Block			

\*STANDARD HARDWARE — PURCHASE LOCALLY

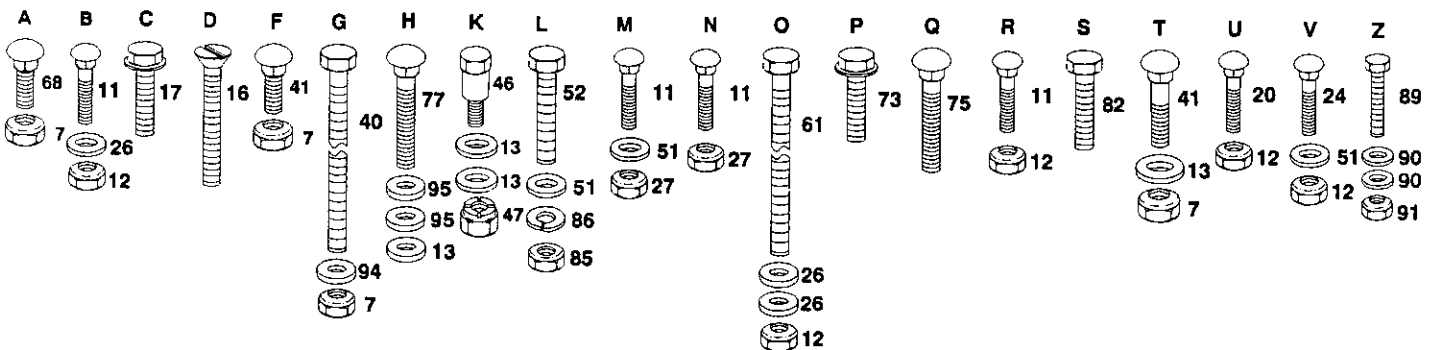

# REPAIR PARTS

18 HP 44" RIDING GARDEN TRACTOR - - MODEL NUMBER 917.255920  
TRANSAXLE

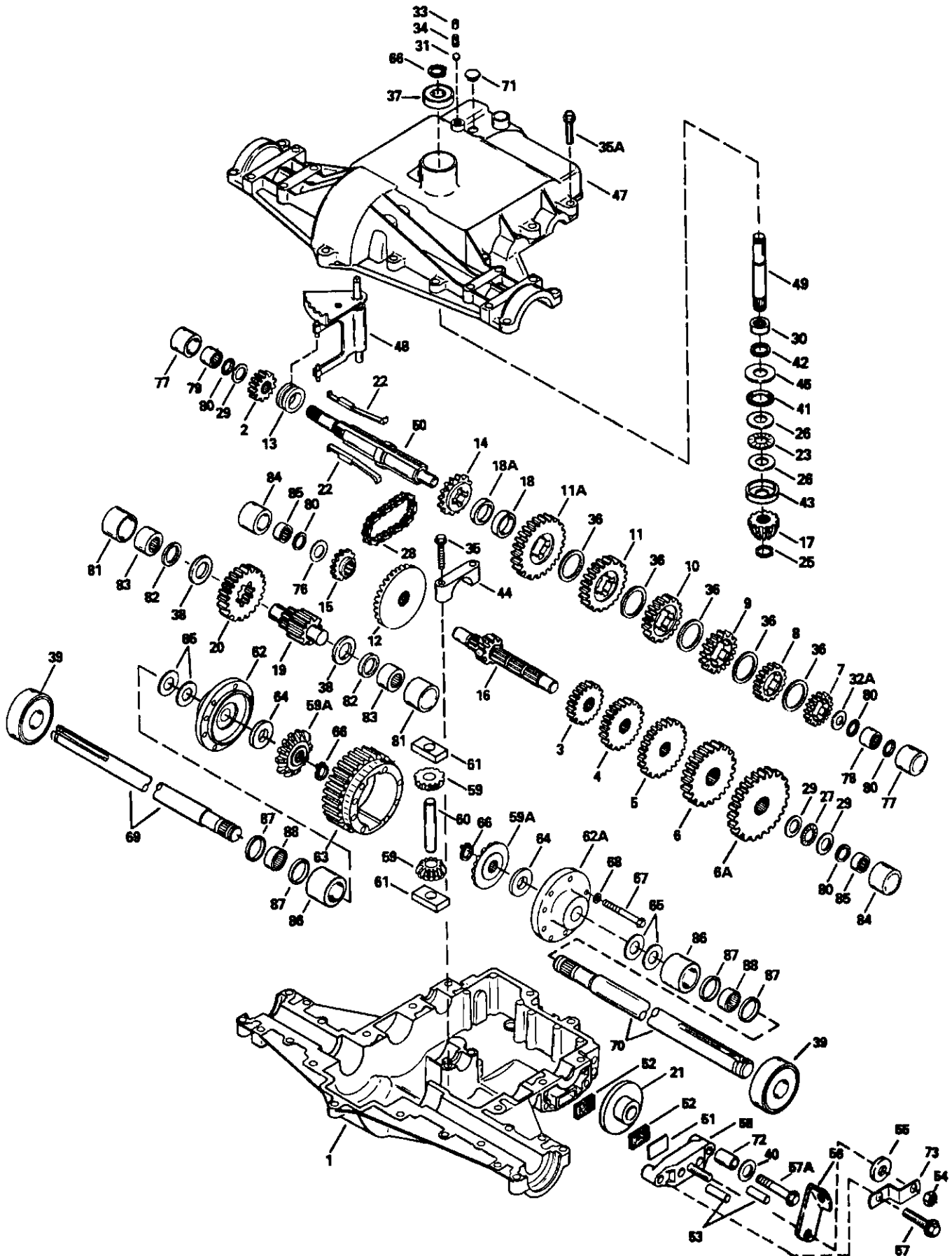



# REPAIR PARTS

18 HP 44" RIDING GARDEN TRACTOR - - MODEL NUMBER 917.255920

## TRANSAXLE

KEY NO.	PART NO.	DESCRIPTION	KEY NO.	PART NO.	DESCRIPTION
1	770088	Case, Transaxle	44	786131	Cap, Bearing
2	778253	Gear, Spur ( 15 teeth)	45	780165	Washer, Flat
3	778211	Gear, Spur (12 teeth)	47	772098	Cover, Transaxle
4	778240	Gear, Spur (18 teeth)	48	784342	Rod & Fork Assy., Shift
5	778201	Gear, Spur (25 teeth)	49	776274	Shaft, Input
6	778202	Gear, Spur (28 teeth)	50	776313	Shaft, Brake (4 Keyed)
6A	778208	Gear, Spur (31 teeth)	51	790007	Plate, Brake pad
7	778209	Gear, Spur (19 teeth)	52	790006	Pad, Brake
8	778203A	Gear, Spur (22 teeth)	53	786026	Pin, Dowel
9	778204A	Gear, Spur (25 teeth)	54	792075	Locknut, 5/16-24
10	778239A	Gear, Spur (32 teeth)	55	792076	Washer, Flat
11	778207A	Gear, Spur (37 teeth)	56	790047	Lever, Brake
11A	778216A	Gear, Spur (41 teeth)	57	792073	Screw, Flanged hex hd. thread-forming, 1/4-20 x 1-1/4
12	778246	Gear, Bevel (33 teeth)	57A	792085	Screw, Flanged hex hd. thread-forming, 1/4-20 x 2-1/4
13	784216	Collar, Shift	58	790025	Holder, Brake pad
14	786123	Sprocket (18 teeth)	59	778197	Pinion, Differential bevel
15	786082	Sprocket (9 teeth)	59A	778198	Gear, Bevel
16	776291	Shaft, Counter (w/9 tooth gear)	60	786019	Pin, Drive
17	778245	Bevel Pinion, Input (13 teeth)	61	786027	Block, Drive
18	786121	Spacer, Neutral (.350/.340 thick)	62	774833	Carrier, Differential (Threaded holes)
18A	786122	Spacer, Neutral (.276/.268 thick)	62A	774834	Carrier, Differential
19	776275	Shaft, Output (9 teeth)	63	778248	Gear, Ring (31 teeth)
20	778247	Gear, Output (35 teeth)	64	780107	Washer
21	790043	Disk, Brake	65	780042	Washer, Thrust
22	792138	Key	66	792018	Ring, Snap
23	780084	Bearing, Thrust	67	792020	Screw, Hex hd., 1/4-20 x 2-1/4
25	788040	Ring, Retaining	68	792006	Lockwasher, 1/4"
26	780051	Washer, Thrust	69	774832	Axle (12-5/16" long)
27	780071	Bearing, Thrust	70	774831	Axle (16-3/16" long)
28	786081	Chain, Roller (No. 41 chain, 24 links)	71	792074	Plug, Hex hd., 9/16-18 thread
29	780072	Washer, Thrust	72	786067	Spacer
30	780155	Bearing, Needle	73	786086	Bracket, Brake lever
31	792077	Ball, Steel	76	780153	Washer
32A	780139	Washer, Thrust	77	786144	Sleeve (stepped)
33	792078	Screw, Set, 3/8-16 x 3/8	78	780150	Bearing, Needle
34	792079	Spring	79	780152	Bearing, Needle (capped)
35	792073	Screw, Flanged hex hd..thread-forming, 1/4-20 x 1-1/4	80	792001	"0" Ring
35A	792129	Screw, Hex hd. thread forming, 5/16-18 x 1-1/4	81	786142	Sleeve (stepped)
36	780108	Washer, Thrust	82	788071	Ring, Square cut
37	780119	Bearing, Ball	83	780049	Bearing, Needle (capped)
38	780128	Washer, Thrust	84	786143	Sleeve (stepped)
39	780050	Bearing, Ball	85	780151	Bearing, Needle (capped)
40	792128	Washer, Flat	86	786145	Sleeve (stepped)
41	788077	"0" Ring	87	788070	Ring, Square cut
42	788042	Seal, Oil	88	780031	Bearing, Needle
43	780166	Washer, Cupped			

# REPAIR PARTS

18 HP 44" RIDING GARDEN TRACTOR - - MODEL NUMBER 917.255920  
ENGINE BRIGGS & STRATTON - MODEL NUMBER 422707, TYPE NUMBER 1211-01

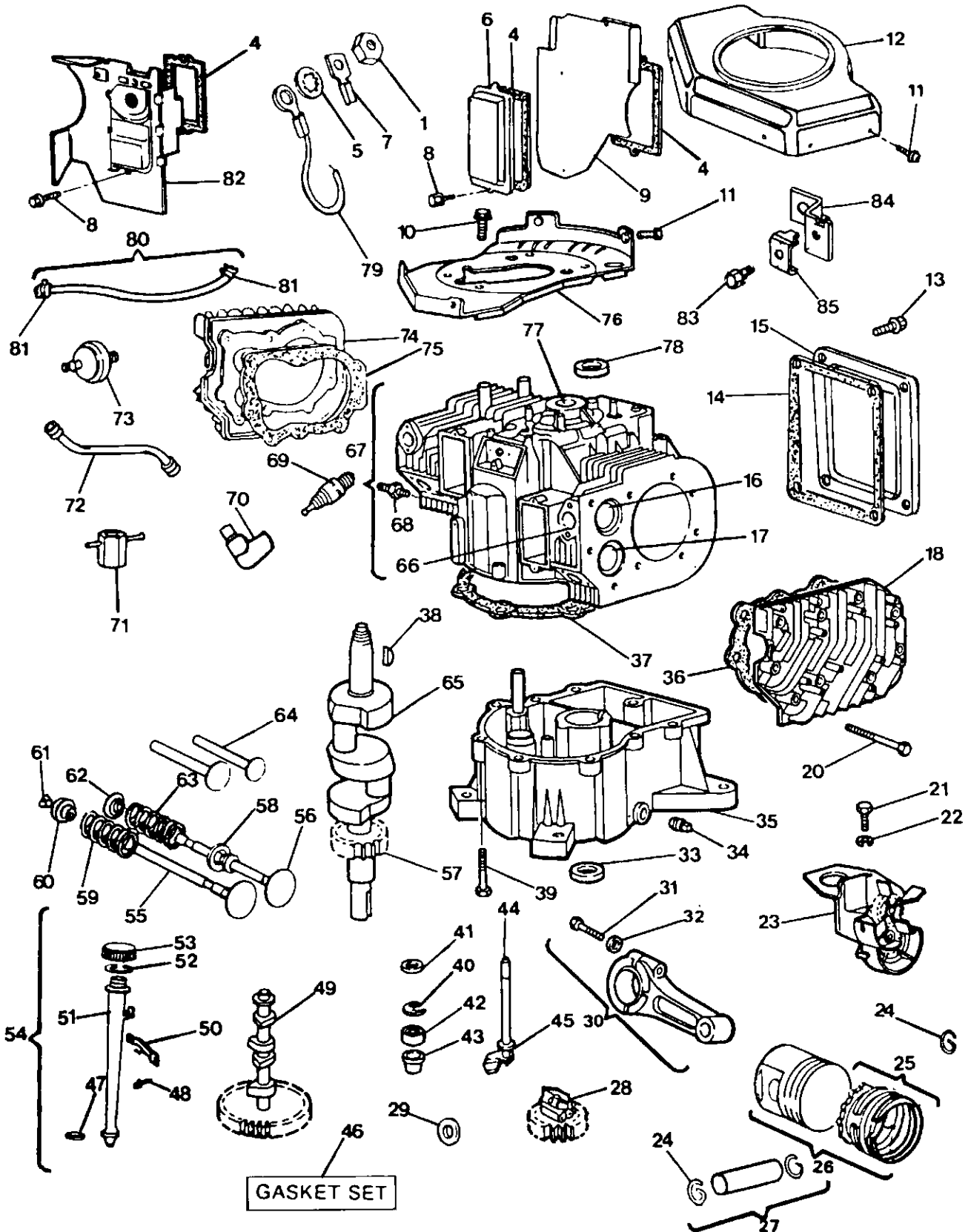

# REPAIR PARTS

## 18 HP 44" RIDING GARDEN TRACTOR - - MODEL NUMBER 917.255920 ENGINE BRIGGS & STRATTON - MODEL NUMBER 422707, TYPE NUMBER 1211-01

KEY NO.	PART NO.	DESCRIPTION	KEY NO.	PART NO.	DESCRIPTION
1	90576	Nut - Hex 8 - 32	39	93585	Screw - Hex Hd. Sem
2	280180	Grommet - Insulator	40	94296	Retainer - E Ring
3	231174	Terminal	41	491287	Foam Seal - Governor Shaft
4	27803	* Gasket - Valve Cover	42	261560	Upper Bushing - Governor
5	92791	Washer - Lock, Shakeproof	43	262332	Lower Bushing - Governor
6	222892	Cover - Breather Cylinder No. 2	44	491530	Crank - Governor
7	93722	Terminal - Spade	45	223882	Washer - Governor Crank (Inside)
8	93394	Screw - Sem	46	394501	Gasket Set
9	222912	Baffle - Air	47	271157	Seal - Filler Tube
10	93777	Screw - Hex Head (Back Plate to Cylinder)	48	93469	Screw - Hex Head
11	93158	Screw - Sem	49	212337	Gear - Cam
12	491247	Housing - Blower	50	222875	Clamp - Oil Filler
13	90887	Screw - Crankcase Cover Mtg. Sem	51	280224	Tube Oil Filler
14	270981	* Gasket - Crankcase	52	271170	Seal - Oil Filler Cap
15	212455	Cover Plate - Crankcase	53	394020	Cap and Dipstick - Oil Filler
16	261463	+ Seat - Intake Valve	54	394394	Dipstick and Tube Assembly (Inc. Key No.'s 47,48,50,51,52 & 53)
17	210940	+ Seat - Exhaust Valve	55	390420	Valve - Exhaust
18	212462	Head - Cylinder No. 2	56	261528	Valve - Intake
20	93211	Screw - Cylinder Head (2 - 5/16" Long)	57	231445	Gear - Timing
21	93686	Screw - Hex Head (10 - 32 x 5/8)	58	393606	Seal Assembly and Retainer
22	92290	Washer - Lock (No. 10 x 1/16 x 3/64)	59	26828	Spring - Exhaust Valve
23	393415	Oil Slinger Assembly	60	292260	Rotocoil - Exhaust Valve
24	260924	Lock - Piston Pin	61	93630	Retainer - Exhaust Valve Rotocoil
25	394959	Ring Set - Piston (Standard)	62	221596	Retainer - Intake Valve
25	394960	Ring Set - Piston (.010" O.S.)	63	65906	Spring - Intake Valve
25	394961	Ring Set - Piston (.020" O.S.)	64	261368	Tappet Valve
25	394962	Ring Set - Piston (.030" O.S.)	65	394028	Crankshaft
26	394955	Piston Assembly (Standard) (Inc.. Key No.'s 24 & 25)	66	261961	+ Guide - Exhaust Valve
26	394956	Piston Assembly (.010" O.S.)	67	491730	Cylinder Assembly (Inc. Key No.68)
26	394957	Piston Assembly (.020" O.S.)	68	230318	Connector - Impulse Pump
26	394958	Piston Assembly (.030" O.S.)	69	394539	Plug - Spark (Resistor)
27	299691	Pin Assembly - Piston (Standard) (Inc..Key No. 24)	70	66538	Elbow - Spark Plug
27	391286	Pin Assembly - Piston (.005" O.S.)	71	89838	Wrench - Spark Plug
28	394348	Gear - Governor	72	280225	Tube - Breather
29	222773	Washer - Thrust	73	394358	Filter - Fuel (In Fuel Line to Tank)
30	394306	Rod Assembly - Connecting(Inc. Key No.'s 31 & 32)NOTE: FOR CONNECTING ROD WITH .020" UNDERSIZE CRANKPIN BORE ORDER NO. 397158	74	212461	Head - Cylinder No. 1
31	92909	Screw - Connecting Rod	75	271867	Gasket - Cylinder
32	220863	Washer	76	491304	Back Plate Assembly
33	291675	Seal - Oil	77	399265	*+ Bearing Cylinder
34	91084	Plug - Oil Drain	78	391086	Seal Oil
35	393552	Base Assembly - Crankcase	79	391115	Wire - Ground
36	271868	* Gasket - Cylinder Head No. 2	80	299146	Line - Fuel (Inc. Key No. 81)
37	271142	* Gasket - Crankcase Cover (1/64" thick)	81	93053	Clamp - Fuel Line
37	271188	* Gasket - Crankcase Cover (.005" thick)	82	393370	Breather Assembly No. 1
37	271189	* Gasket - Crankcase Cover (.009" thick)	83	93496	Screw - Hex Head
38	222698	Key - Flywheel	84	223890	Bracket - Choke Cable
			85	221535	Clamp - Casing

\* INCLUDED IN GASKET SET  
394501 SPECIAL TOOLS  
REQUIRED TO INSTALL

# REPAIR PARTS

18 HP 44" RIDING GARDEN TRACTOR - - MODEL NUMBER 917.255920  
 ENGINE BRIGGS & STRATTON - MODEL NUMBER 422707, TYPE NUMBER 1211-01

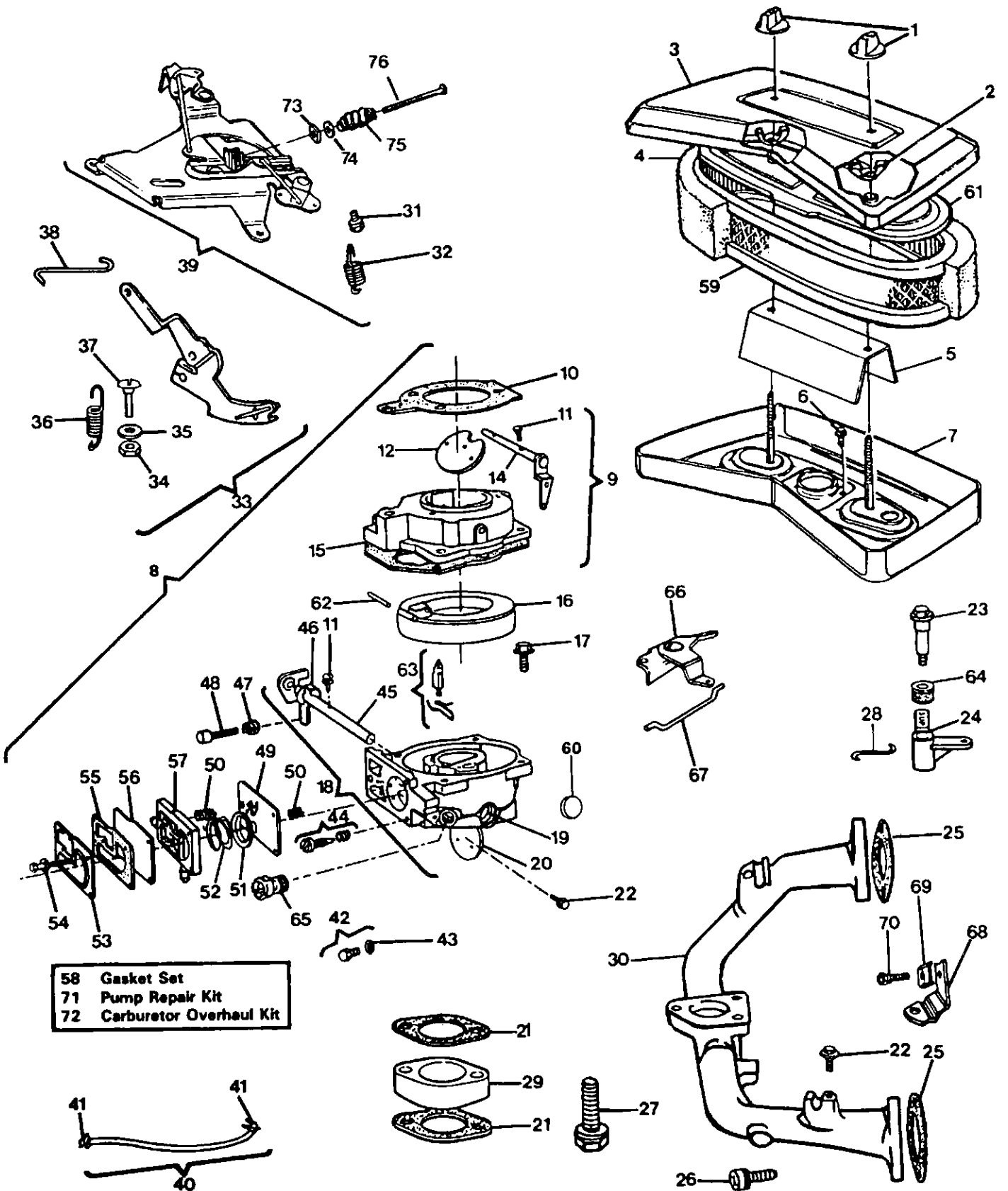

# REPAIR PARTS

**18 HP 44" RIDING GARDEN TRACTOR - - MODEL NUMBER 917.255920**  
**ENGINE BRIGGS & STRATTON - MODEL NUMBER 422707, TYPE NUMBER 1211-01**

KEY NO.	PART NO.	DESCRIPTION	KEY NO.	PART NO.	DESCRIPTION
1	212706	Knob - Air Cleaner	40	393815	Impulse Line and Clamp Assembly (Inc Key No. 41 )
2	94289	Nut - Hex	41	93053	Clamp - Fuel Line
3	223579	Cover - Air Cleaner	42	397882	Plug and Seal, Solenoid
4	271271	Element - Air Cleaner	43	280474	O Ring Seal
5	224039	Mounting Strap Assembly - Air Cleaner	44	491538	+ Valve Assembly - Carburetor Idle
6	94166	Screw - Hex Head	45	392672	Shaft and Lever - Throttle
7	398826	Body - Air Cleaner	46	271013	+ Washer - Choke Shaft
8	491535	Carburetor Assembly (Inc. Key No.'s 9, 10, 11, 12, 13, 14, 15, 16, 17, 18, 19, 20, 42, 43, 44, 45, 46, 47, 48, 49, 50, 51, 52, 53, 54, 55, 56, 57, 62 & 63)	47	26157	Spring - Throttle Adjustment
9	399535	Body Assembly - Upper Carburetor	48	91920	Screw - Machine Fill.Hd.(8/32 x 5/8)
10	271411	Gasket - Air Cleaner	49	270988	x Diaphragm
11	93499	Screw - Throttle and Choke	50	261358	x Spring
12	223534	Valve - Choke	51	221377	x Cap - Spring
14	392673	Shaft and Lever - Choke	52	261395	x Spring - Pump
15	271607	+ Gasket - Carburetor Body	53	223688	Cover - Diaphragm
16	298514	Float Carburetor	54	93829	Screw Diaphragm - Damping
17	94152	Screw - Hex Head Sem (10 32 x 3/4)	55	271025	x Casket - Carburetor Pump
18	491543	Body - Lower Carburetor (Inc. KeyNo.'s 11,19,20,45 & 46)	56	270989	x Diaphragm - Damping
19	231209	Bushing Throttle - Shaft	57	280197	Body Pump
20	221939	Valve - Throttle	58	394501	Gasket Set
21	271412	+* Gasket Carburetor and Intake Elbow	59	394019	Cartridge - Air Cleaner
22	93897	Screw Sem	60	223472	Plug - Welch
23	93971	Screw Hex Head	61	223714	Cartridge Plate - Air Cleaner
24	280818	Crank - Bell	62	230896	+ Pin - Float Hinge
25	270884	* Gasket - Intake Manifold Mounting	63	394681	+ Valve - Fuel Inlet
26	93208	Screw Intake Manifold Mounting	64	271013	Washer
27	93970	Screw - Hex Head	65	231338	Jet - Needle Valve
28	261587	Link - Throttle	66	490207	Crank - Bell
29	280319	Spacer - Carburetor	67	262375	Link
30	213290	Manifold Assembly - Intake	68	223893	Bracket - Speed Control
31	93949	Screw - Sem	69	221535	Clamp - Casing
32	262351	Spring - Governor	70	93496	Screw - Hex Head
33	491297	Lever Assembly - Governor (Inc. Key No.'s 34, 35 & 37)	71	393397	Repair Kit - Pump
34	92278	Nut - Hex (10 - 24)	72	491539	Overhaul Kit - Carburetor
35	222289	Washer	73	94298	Nut - Square
36	261563	Spring - Governor Idle	74	223882	Washer
37	93853	Bolt - Governor Lever	75	262337	Spring - Compression
38	261586	Link - Governor	76	94297	Screw - Pan Head
39	491282	Plate Assembly - Governor Control			

\* INCLUDED IN GASKET SET PART NO. 394501  
+ INCLUDED IN CARBURETOR OVERHAUL KIT PART NO. 491539X  
x INCLUDED IN CARBURETOR OVERHAUL KIT PART NO. 491539 AND PUMP REPAIR KIT PART NO.393397

# REPAIR PARTS

18 HP 44" RIDING GARDEN TRACTOR - - MODEL NUMBER 917.255920  
ENGINE BRIGGS & STRATTON - MODEL NUMBER 422707, TYPE NUMBER 1211-01

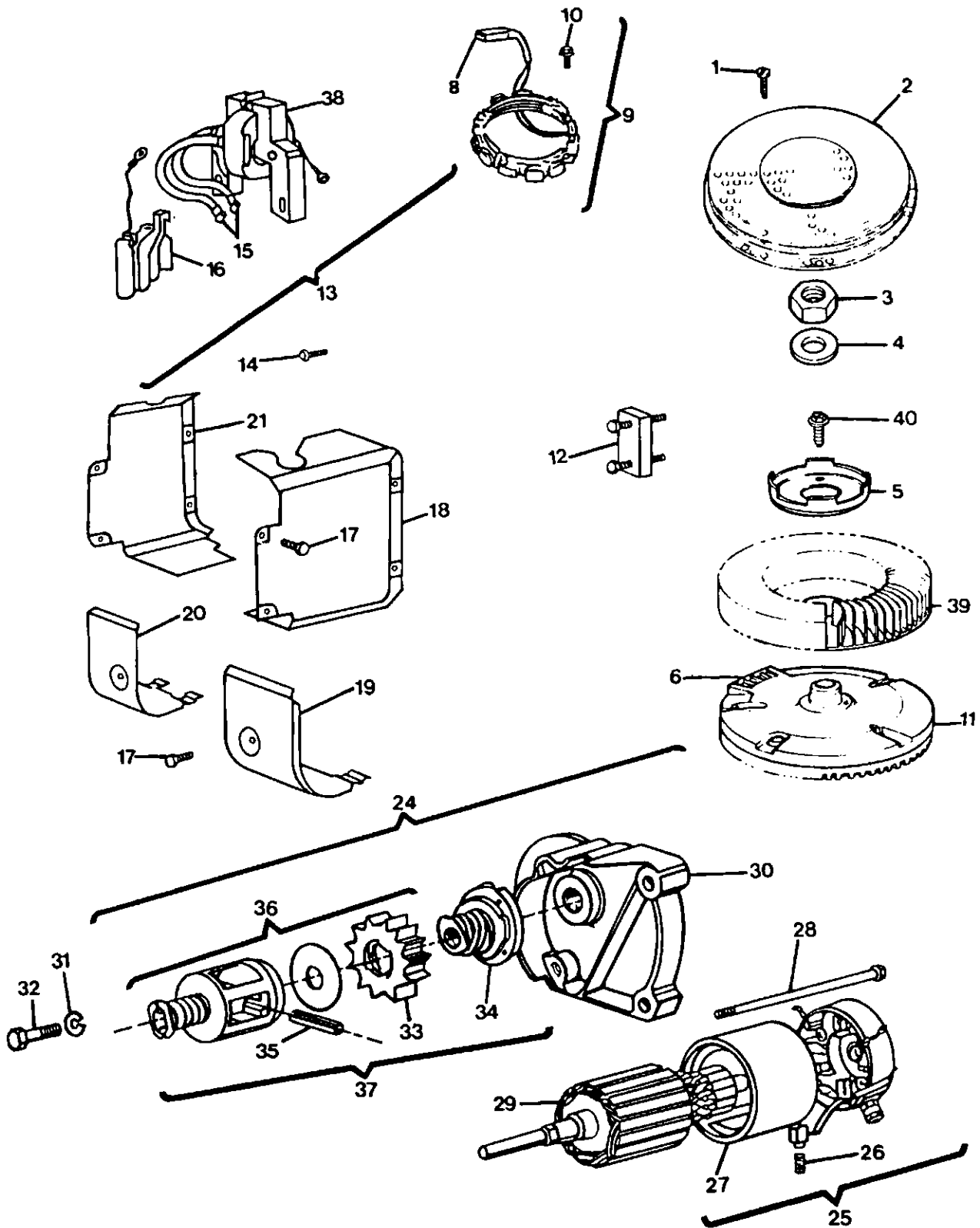

## REPAIR PARTS

18 HP 44" RIDING GARDEN TRACTOR - - MODEL NUMBER 917.255920  
 ENGINE BRIGGS & STRATTON - MODEL NUMBER 422707, TYPE NUMBER 1211-01

KEY NO.	PART NO.	DESCRIPTION	KEY NO.	PART NO.	DESCRIPTION
1	94326	Screw - Sem	21	222848	Cover - Air Guide
2	222673	Screen - Flush Rotating	24	394808	Motor - Starting (Inc. Key No.'s 25,26, 27, 28, 29, 30, 33, 34, 35, 36 and 37)
3	230674	Nut Hex	25	395537	Commutator End Cap Assembly
4	222511	Washer - Spring	26	395538	Starter (Inc Key No. 26)
5	223726	Retainer - Fan	27	393825	Brush Set
6	491180	Flywheel and Ring Gear Assembly - Magneto	28	94003	Housing Assembly
8	393456	Diode and Connector Assembly	29	390837	Thru Bolt
9	393474	Stator - Alternator (Dual Circuit) (Inc.Key No. 8)	30	394860	Armature Assembly (Motor)
10	93621	Screw - Sem	31	90366	Drive End Cap Assembly - Starter
11	391362	Gear - Flywheel Ring (Includes Mounting Parts)	32	91162	Lockwasher
12	19203	Puller - Flywheel (Optional Accessory)	33	280104	Screw - Hex Hd. (5,16 18 x 1-1 /2 )
13	394891	Armature Group (Inc. Key No.'s 15, 16 & 38)	34	398003	Gear - Starter
14	93381	Screw - Armature Mount:ng Sem	35	94288	Clutch Assembly - Starter
15	221798	Terminal - Ignition Cable	36	490467	Roll Pin
16	394970	Trigger - Coil Assembly Magnatron Ignition	37	490421	Pinion Spring Kit (Inc. Key No's. 33 & 55)
17	93163	Screw - Sem	38	394988	Starter - Drive Group (Inc Key No 's 33, 34, 35 & 36)
18	222849	Cover - Air Guide	39	280815	Armature Assembly
19	222847	Shield - Cylinder	40	93535	Fan - Flywheel
20	222846	Shield - Cylinder			Screw - Sem

---

# SERVICE NOTES

---