



REPAIR PARTS MANUAL
MODEL NO. 258330
Lawn Tractor

CRAFTSMAN®

HOW TO USE THIS MANUAL

This manual is designed to provide the customer with a means to identify the parts on his/her tractor when ordering repair parts. The illustrations may or may not represent the actual assemblies; therefore, it is not recommended to use this manual as a guide to assemble or disassemble the tractor. Some hardware and parts are drawn larger in order to more readily identify them.

Each tractor has its own model number.

The model number for your tractor can be found on the fender under the seat.

When ordering parts, always give the following information:

- Product - "Tractor"
- Model Number - "258330"
- Part Number
- Part Description

TABLE OF CONTENTS

SCHEMATIC	3
ELECTRICAL	4-5
CHASSIS	6-7
DRIVE	8-9
STEERING WHEEL	10-11
SEAT	12
DECALS	13
ENGINE	14
MOWER LIFT LEVER.....	15
MOWER DECK	16-17
TRANSAXLE	18-19

TRACTOR - - MODEL NUMBER 917.258330

SCHEMATIC

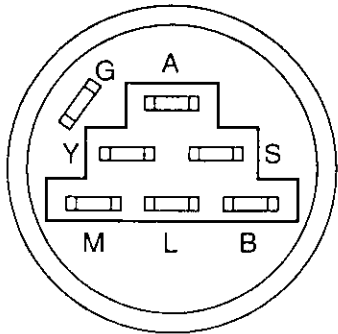
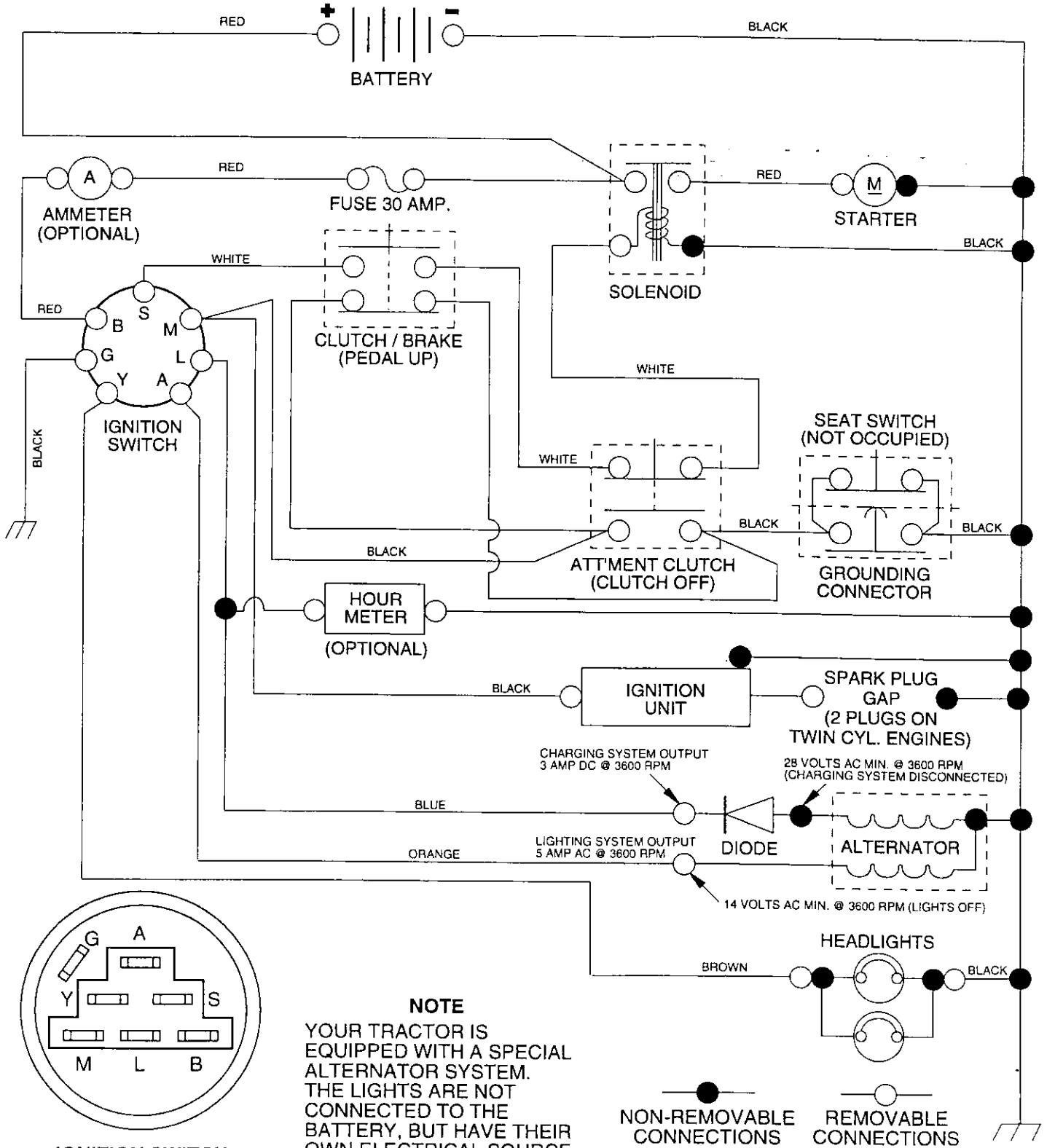

IGNITION SWITCH

POSITION	CIRCUIT	"MAKE"
OFF	G + M + L	NONE
RUN/LIGHT	B + L	A + Y
RUN	B + L	NONE
START	B + L + S	NONE

NOTE

YOUR TRACTOR IS EQUIPPED WITH A SPECIAL ALTERNATOR SYSTEM. THE LIGHTS ARE NOT CONNECTED TO THE BATTERY, BUT HAVE THEIR OWN ELECTRICAL SOURCE. BECAUSE OF THIS, THE BRIGHTNESS OF THE LIGHTS WILL CHANGE WITH ENGINE SPEED. AT IDLE THE LIGHTS WILL DIM. AS THE ENGINE IS SPEEDED UP, THE LIGHTS WILL BECOME THEIR BRIGHTEST.

WIRING INSULATED CLIPS

NOTE: IF WIRING INSULATED CLIPS WERE REMOVED FOR SERVICING OF UNIT, THEY SHOULD BE REPLACED TO PROPERLY SECURE YOUR WIRING.

REPAIR PARTS

TRACTOR - - MODEL NUMBER 917.258330

ELECTRICAL

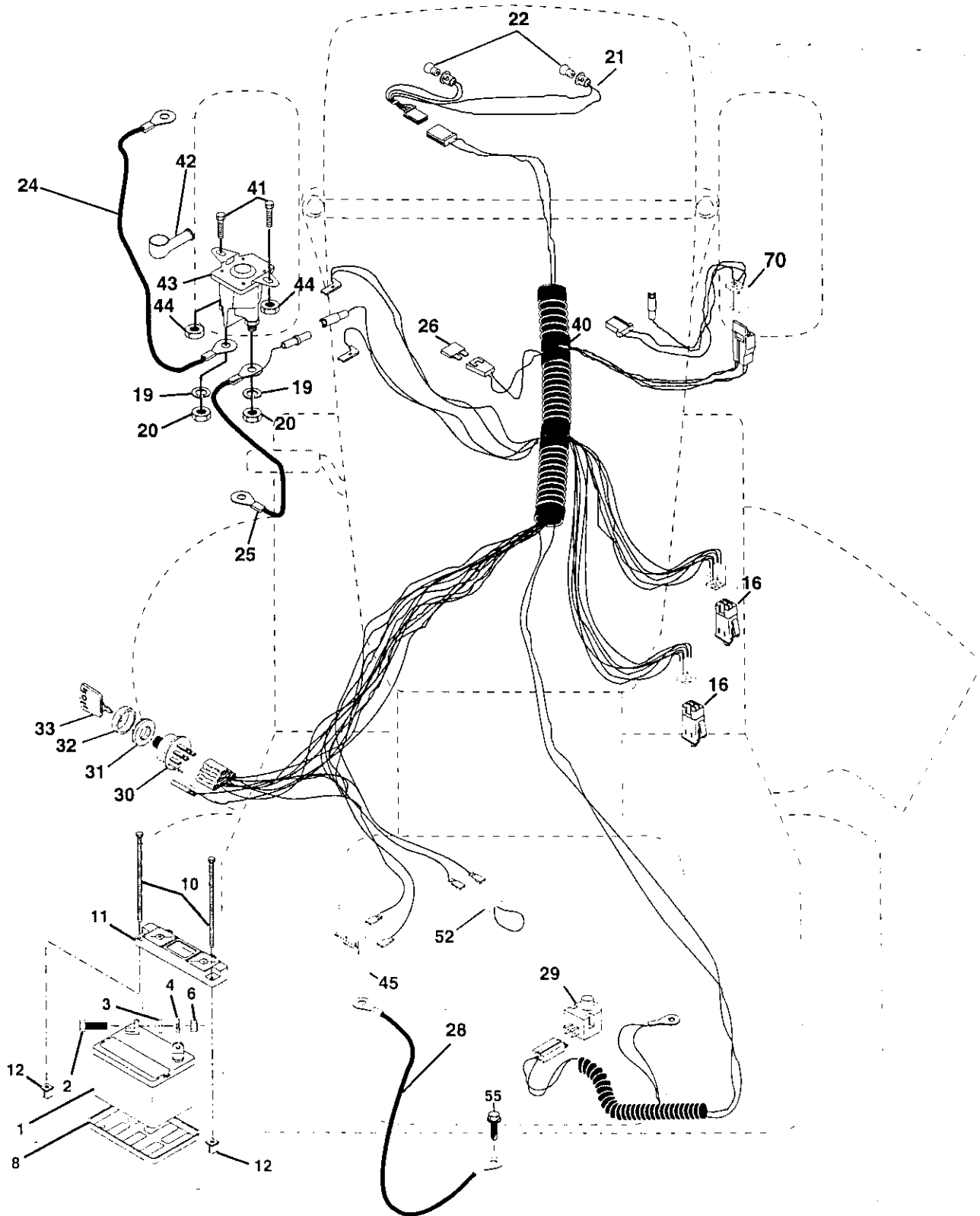

REPAIR PARTS

TRACTOR - - MODEL NUMBER 917.258330

ELECTRICAL

KEY NO.	PART NO.	DESCRIPTION
1	163465	Battery
2	74760412	Bolt, Hex 1/4-20 x 3/4
3	STD551025	Washer 9/32 x 5/8 x 16 Gauge
4	STD551125	Washer, Lock 1/4
6	STD541025	Nut, Hex 1/4-20
8	7603J	Tray, Battery
10	145211	Bolt, Btr Front 1/4-20 x 7-1/2
11	150109	Holddown Battery Front Mount
12	145769	Nut, Push Nylon Battery Front 1/4
16	153664	Switch Interlock Push-In
19	STD551125	Washer, Lock 1/4
20	73350400	Nut, Hex, Jam 1/4-20
21	147430	Harness, Light Socket (w/4152J)
22	4152J	Light Bulb
24	4799J	Cable, Battery
25	146148	Cable, Battery
26	108824X	Fuse
28	145491	Cable, Ground
29	121305X	Switch, Seat
30	140301	Switch, Ignition 4 Position
31	124211X	Nut, Ignition
32	141226	Cover, Ignition Switch
33	109310X	Key, Molded, Craftsman
40	156442	Harness, Ignition
41	71110408	Bolt Blk Fin Hex 1/4-20 UNC x 1/2
42	131563	Cover, Terminal
43	145673	Solenoid
44	73640400	Nut Keps Blk Hex 1/4-20 UNC
45	121433X	Ammeter Rectangular 6 Amp
52	141940	Protection Wire Loop (Hour Meter)
55	17490508	Screw Thdrol 5/16-18 x 1/2
70	140413	Harness Engine B&S/Tec Dual

NOTE: All component dimensions given in U.S. inches
1 inch = 25.4 mm

REPAIR PARTS

TRACTOR - - MODEL NUMBER 917.258330

CHASSIS AND ENCLOSURES

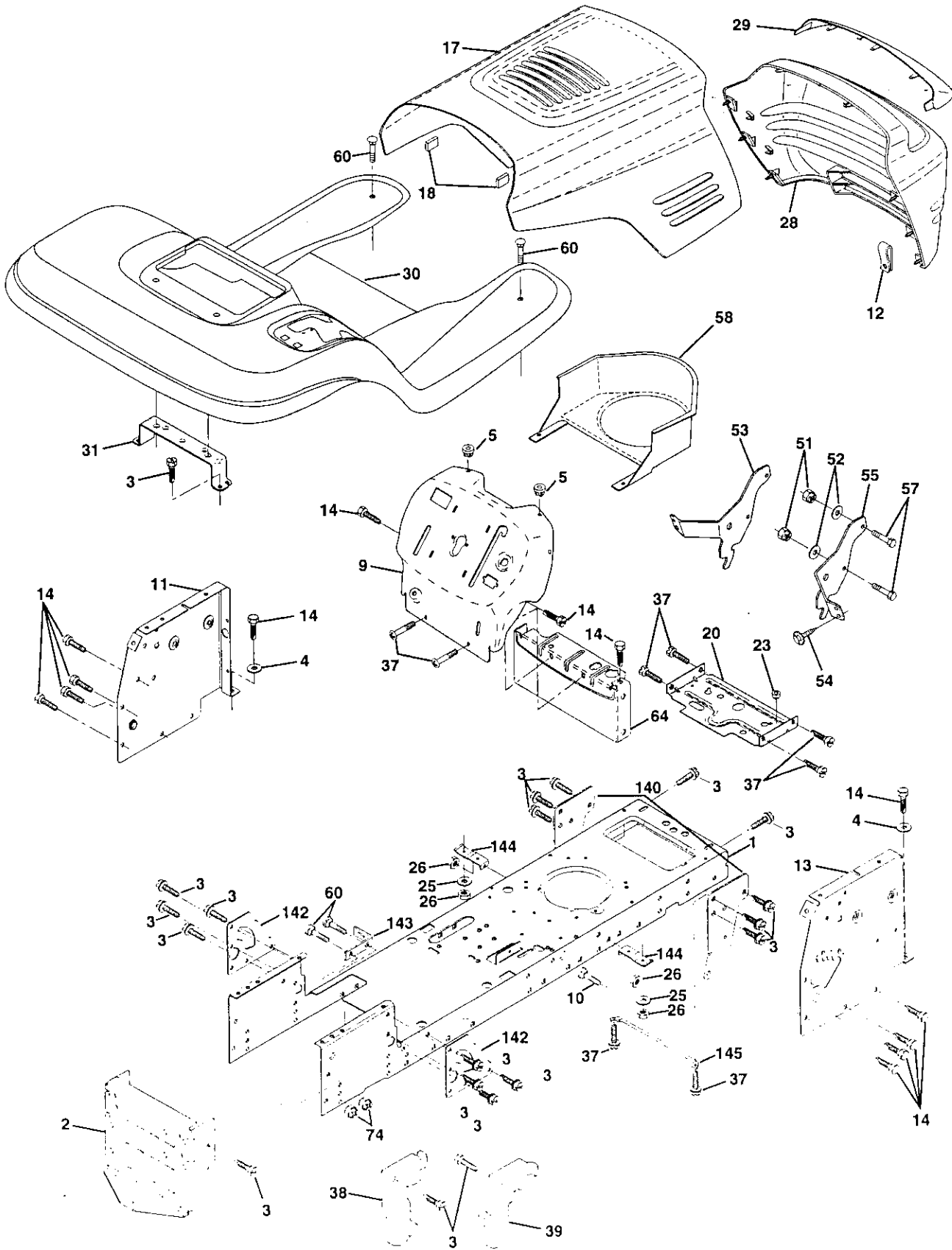

REPAIR PARTS

TRACTOR - - MODEL NUMBER 917.258330

CHASSIS AND ENCLOSURES

KEY NO.	PART NO.	DESCRIPTION
1	160392	Chassis
2	140356	Drawbar
3	17490612	Screw, Thd., Roll. 3/8-16 x 3/4 Type TT
4	STD551025	Washer 13/32 x 3/4 x 16 Gauge
5	155272	Bumper Hood/Dash
9	161917X012	Dash, Silkscreened
10	STD533710	Bolt, Carriage 3/8-16 x 1
11	155927	Panel, Dash, LH
12	145660	Clip Tinnerman Grille P/L
13	155936	Panel, Dash, RH
14	17490608	Screw, Thd., Roll. 3/8-16 x 1/2 Type TT
17	144983X558	Hood Assembly
18	126938X	Bumper Hood
20	156437	Plate Mtg Battery Fuel Tank
23	124028X	Bushing, Snap, Nylon, Fuel Line
25	19131312	Washer 13/32 x 13/16 x 12 Gauge
26	STD541437	Locknut, Hex, with Insert 3/8-16 UNC
28	145198X558	Grille, W/Clips MS-558
29	155217	Lens, Grille
30	151287X558	Fender/Footrest
31	139976	Bracket, Fender/Support
37	17490508	Screw, Thdrol. 5/16-18 x 1/2 TYT
38	139886	Pivot Bracket Assembly, LH, Mower, Rear
39	139887	Pivot Bracket Assembly, RH, Mower, Rear
51	73800400	Nut Lock W/Insert 1/4 - 20 UNC
52	19091416	Washer 9/32 X 7/8 X 16 Ga.
53	145201	Bracket Grille Pickoff LH
54	161464	Screw, Hex Wshd #8-18 x 7/8
55	145202	Bracket Grille Pickoff RH
57	STD552507	Bolt FinHex 1/4 -20 UNC X.75
58	140547	Air Duct P/L 18HP B&S Opp. Twin
60	72140606	Bolt Rdhd Sqnk 3/8-16 UNC x 3/4
64	154798	Dash Lower STLT
74	STD541437	Nut Crownlock 3/8-16 UNC
140	158418	Bracket Suspension Front
142	156095	Plate Reinforcement STLT
143	154966	Bracket Swaybar Chassis
144	154207	Bracket Footrest STLT
145	156524	Rod Pivot Chassis/Hood

NOTE: All component dimensions given in U.S. inches
1 inch = 25.4 mm

REPAIR PARTS

TRACTOR - - MODEL NUMBER 917.258330

DRIVE

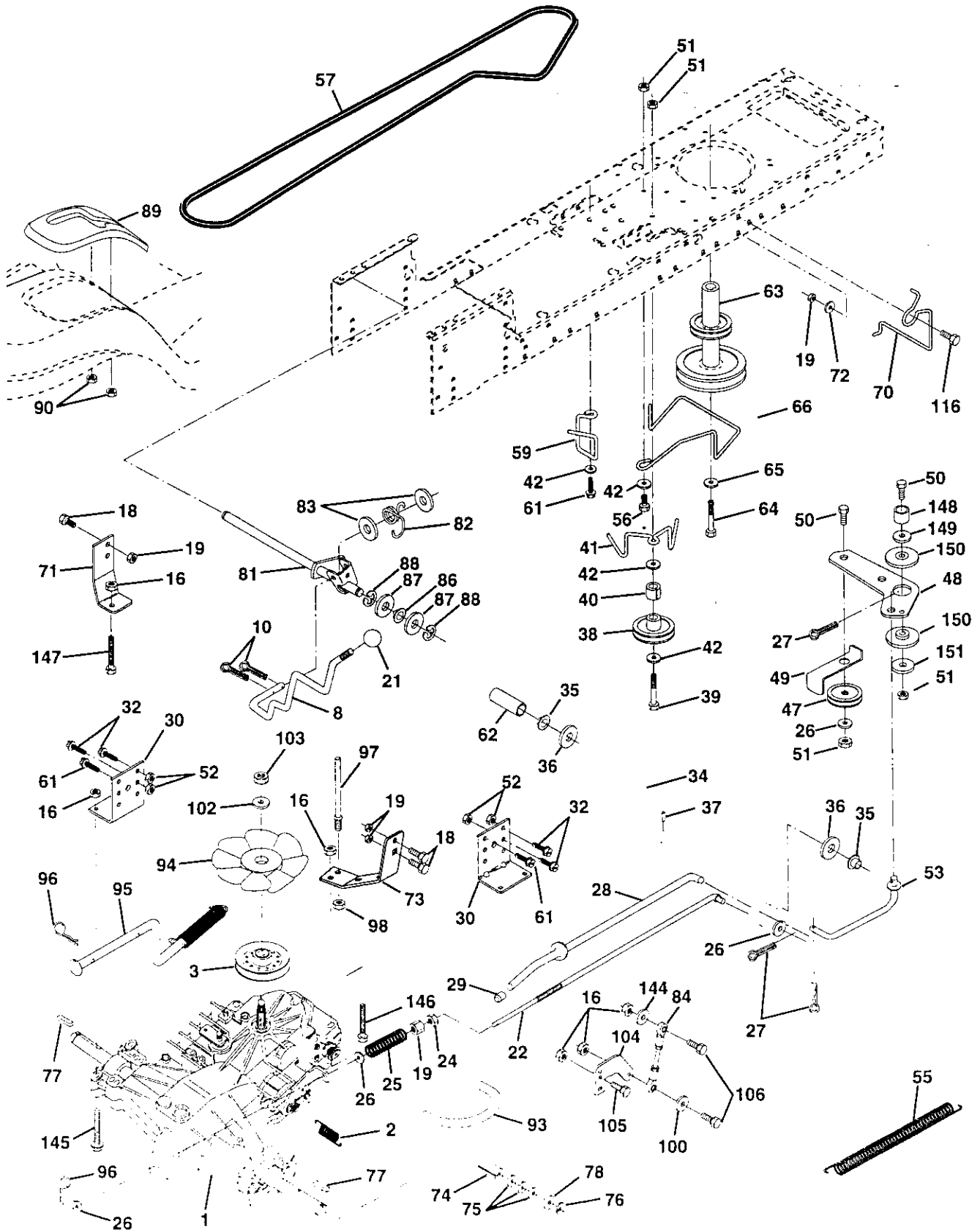

REPAIR PARTS

TRACTOR - - MODEL NUMBER 917.258330

DRIVE

KEY NO.	PART NO.	DESCRIPTION	KEY NO.	PART NO.	DESCRIPTION
1	150071	Transaxle (See Breakdown)	65	STD551143	Washer
2	142431	Hydro Gear Model No. 310-0650	66	161488	Keeper Belt Engine Hydro
3	143995	Spring, Return, Brake	70	134683	Guide Belt RH Engine
8	154792	Pulley, Transaxle	71	140158	Strap Torque Lh Hydro 18/20" T
10	STD561210	Rod Shift Fender STLT	72	19132012	Washer 13/32 x 1-1/4 x 12 Ga.
16	STD541431	Pin Cotter 1/8 x 1 CAD	73	156347	Strap Torque Rh Hydro 0650
18	STD523710	Nut Lock Hex W/Ins. 5/16-18 Unc	74	121199X	Spacer, Split
19	STD541437	Bolt Fin Hex 3/8-16 Unc x 1 Gr. 5	75	121749X	Washer 25/32 x 1-1/4 x 16 Gauge
21	130564	Nut Lock Hex W/Wsh 3/8-16 Unc	76	STD581075	E-Ring
22	145627	Knob, Deluxe 1/2-13	77	123583X	Key, Square
24	73350600	Rod, Brake Hydro	78	121748X	Washer 25/32 x 1-5/8 x 16 Gauge
25	106888X	Nut, Hex Jam 3/8-16 Unc	81	161079	Shaft Asm. Cross Hydro 20" Tires
26	STD551037	Spring, Brake Rod	82	123782X	Spring Torsion T/A
27	STD561210	Washer	83	19171216	Washer 17/32 x 3/4 x 16 Ga.
28	145204	Pin Cotter 1/8 x 3/4 CAD.	84	161901	Rod, Tie Hydro 20" Tires
29	124236X	Rod, Parking Brake	86	157480	Bushing
30	130807	Cap, Parking Brake	87	19212016	Washer 21/32 x 1-1/4 x 16 Ga.
32	74760512	Bracket, Transaxle	88	12000008	Ring Klip #5304-62
34	155071	Bolt Hex Hd 5/16-18 Unc x 3/4	89	158388	Console, Shift
35	120183X	Shaft, Foot Pedal	90	124346X	Nut Self-Thd Wsh-hd 1/4 Zinc
36	19211616	Bearing, Nylon	93	142564	Line Fuel Hydro 4"
37	1572H	Washer	94	140462	Fan, Hydro 7"
38	123674X	Pin, Roll	95	144643	Control Bypass Hydro 20" Tires
39	STD523727	Pulley, Idler, Flat	96	4497H	Retainer Spring 1" Zinc/Cad
40	4470J	Bolt	97	140469	Keeper Bolt Rh Hydro 0750. 18/20"
41	154777	Spacer, Split	98	73510600	Nut Keps Hex 3/8-16 Unc
42	19131312	Keeper, Belt Idler	100	19111216	Washer 11/32 x 3/4 x 16 Ga.
47	127783	Washer 13/32 x 13/16 x 12 Gauge	102	141322	Washer Bellville .501D x 1.50D
48	154407	Pulley, Idler, V-Groove	103	73940800	Nut Hex Jam Toplock 1/4-20 Unf
49	123205X	Bellcrank Clutch Grnd Drv STL	104	140156	Arm, Control Hydro
50	STD523715	Retainer, Belt	105	71070516	Screw Cap Hex 5/16 x 18 x 1
51	STD541437	Bolt	106	74780520	Bolt Fin Hex 5/16-18 Unc x 1-1/4
52	STD541431	Nut Crownlock 3/8-16 UNC	116	72110610	Bolt Carr. 3/8-16 x 1.25
53	105710X	Nut, Crownlock 5/16-18 Unc	144	19111016	Washer 11/32 x 5/8 x 16 Ga.
55	105709X	Link, Clutch	145	74490540	Bolt Hex Flghd 5/16-18 Gr. 5
56	STD523712	Spring, Return, Clutch	146	74490536	Bolt Fin Hex 5/16-18 x 2-1/4
57	161588	Bolt Hex 3/8-16 x 1-1/4	147	74490524	Bolt Fin Hex 5/6-18 Unc x 1-1/2
59	140312	V-Belt, Ground Drive	148	159103	Spacer
61	17490612	Keeper, Center Span	149	122052X	Spacer Retainer PM Mower
62	8883R	Screw Thdrol. 3/8-16 x 3/4 Ty. TT	150	150935	Bushing Nylon Collered
63	161399	Cover, Pedal	151	19133210	Washer 13/32 x 2 x 10 Ga.
64	71170764	Pulley, Engine			
		Bolt Hex 7/16-20 x 4 Gr. 5			

NOTE: All component dimensions given in U.S. inches
1 inch = 25.4 mm

REPAIR PARTS

TRACTOR -- MODEL NUMBER

STEERING ASSEMBLY

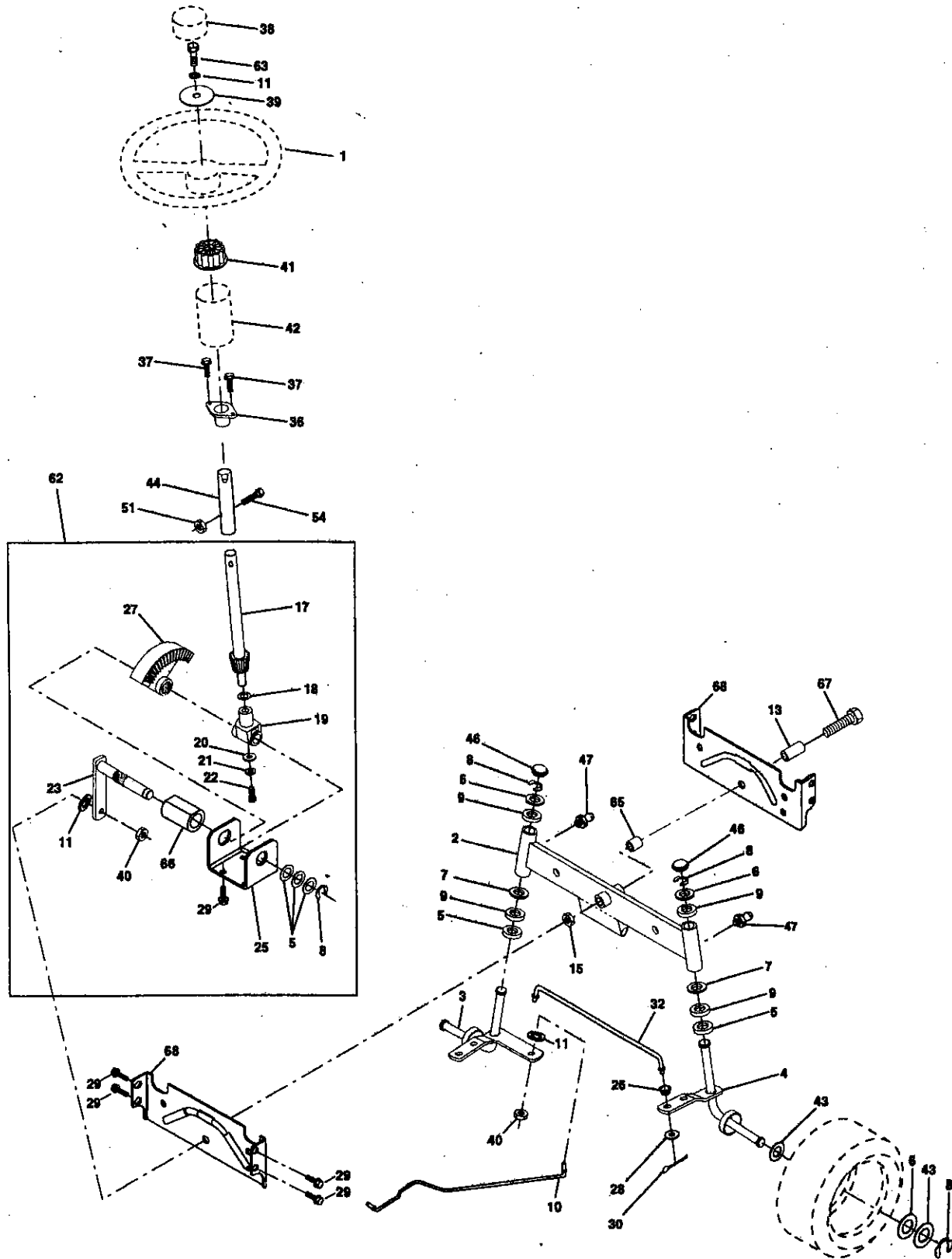

REPAIR PARTS

TRACTOR - - MODEL NUMBER 917.258330

STEERING ASSEMBLY

KEY NO.	PART NO.	DESCRIPTION
1	139768	Wheel Steering Std Black
2	154427	Axle Asm Front
3	156483	Spindle Asm Lh
4	157473	Spindle Asm Rh
5	6266H	Bearing Race Thrust Harden
6	121748X	Washer 25/32 X 1 5/8 X 16ga
7	19272016	Washer 27/32 X 1 1/4 X 16 Ga
8	12000029	Ring Klip #t5304-75
9	3366R	Bearing Col Strg Bik
10	156438	Link Drag Extended Stamped
11	STD551137	Washer Lock Hvy Hlcl Spr 3/8
13	154779	Bearing Axle STLT/GT
15	73901000	Locknut Flange 5/8-11 UNC
17	156546	Shaft Asm Strg Private Label
18	57079	Washer Thrust 515x 750x 033
19	124035X	Support Shaft
20	126684X	Washer Shim 1/4 X 5/8 X .062
22	71200410	Screw Hex Sckt 1/4-20 x 5/8
23	127501	Shaft Asm Pittman
25	154406	Bracket Steering
26	126847X	Bushing Rod Tie Blk Lt
27	136874	Gear Sector
28	19131416	Washer 13/32 X 7/8 X 16ga
29	17490612	Screw Thdrol 3/8-16x3/4 Ty-tt
30	STD561210	Pin Cotter 1/8 X 3/4 Cad
32	130465	Rod Tie Wire Form 19 75 Mech
36	155099	Bushing Strg 5/8 Id Dash
37	152927	Screw TT #10-32x5x3/8 Flange
38	139769	Insert Cap Strg Wheel Std Blk
39	19133808	Washer 13/32 X 2-3/8 X 8 Ga
40	7810H	Nut Lock Center 3/8-24 UNF
41	100711L	Adaptor Wheel Strg
42	145054	Boot Shaft Steering
43	121749X	Washer 25/32 X 1 1/4 X 16 Ga
44	153720	Extension Steering Non-Adjust
46	121232X	Cap Spindle Fr Top Blk
47	6855M	Fitting Grease
51	73800500	Nut Lock Hex W/Ins 5/16 -18 UNC
54	74780520	Bolt Fin Hex 5/16 - 18 UNC X 1 -1/4
62	156594	Kit, Steering Assembly
63	74780616	Bolt Fin Hex 3/8-16unc x 1 Gr.5
65	154780	Spacer Axle
66	154404	Bearing Arm Pittman
67	74781044	Bolt Fin Hex 5/8-11 UNC x 2-3/4
68	154429	Axle Brace

NOTE: All component dimensions given in U.S. inches
1 inch = 25.4 mm

REPAIR PARTS

TRACTOR -- MODEL NUMBER 917.258330

SEAT ASSEMBLY

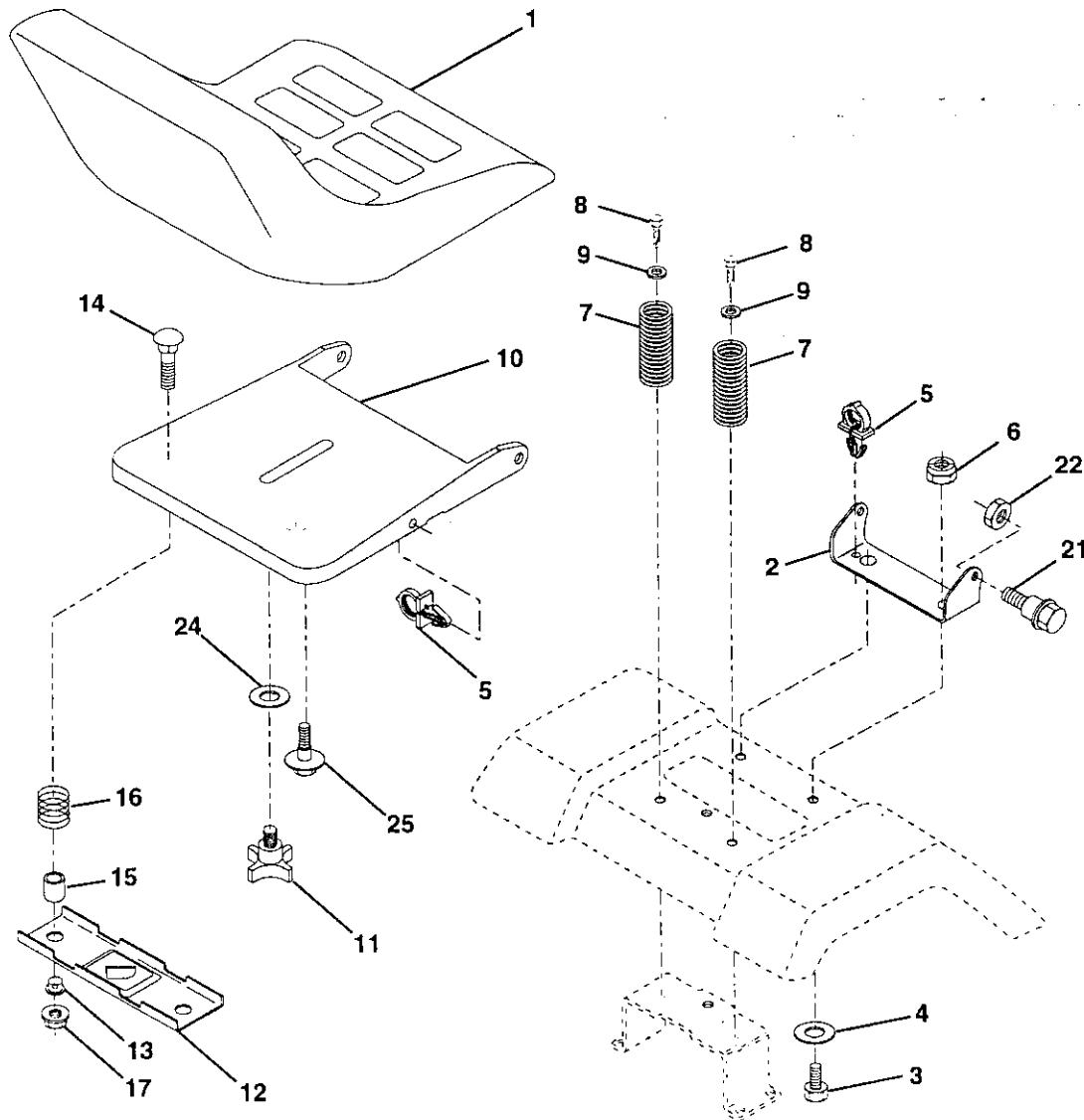

KEY NO.	PART NO.	DESCRIPTION
1	140123	Seat
2	140551	Bracket Pnt Pivot Seat (blk)
3	74760616	Bolt Fin Hex 3/8-16 UNC x 1
4	19131610	Washer Flat 13/32 x 1 x 10 Ga
5	145006	Clip Push-In
6	STD541437	Nut Lock Hex W/Ins 3/8 -16 UNC
7	124181X	Spring Seat Cprsn 2 250 Blk Zi
8	17490616	Screw 3/8-16x1
9	19131614	Washer 13/32 x 1 x 14 Ga
10	155925	Pan Pnt Seat (blk)
11	120068X	Knob Seat 1/2-13 UNC Blk
12	121246X	Bracket Pnt Mounting Switch

KEY NO.	PART NO.	DESCRIPTION
13	121248X	Bushing Snap Blk Nyl 50 Id
14	72050412	Bolt Rdhd Sht Nk 1/4-20x1-1/2
15	134300	Spacer Split 28 X 96 Zinc
16	121250X	Spring Cprsn 1 27 Blk Pnt
17	123976X	Nut Lock 1/4 Lge Flg Gr 5 Zinc
21	153236	Bolt Shoulder 5/16-18 Unc
22	STD541431	Nut Lock Hex W/Ins 5/16-18
24	19171912	Washer 17/32 X 1-3/16 X 12 Ga
25	127018X	Bolt Shoulder 5/16-18 X 62

NOTE: All component dimensions given in U.S. inches
1 inch = 25.4 mm

REPAIR PARTS

TRACTOR - - MODEL NUMBER 917.258330

DECALS

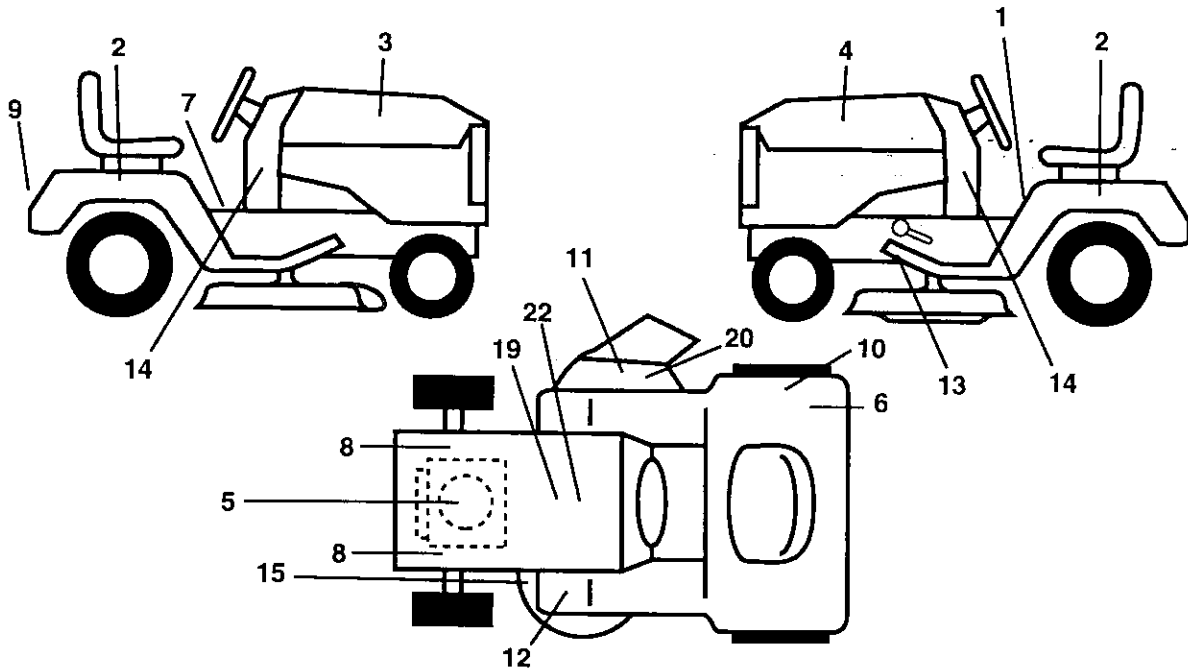

KEY NO.	PART NO.	DESCRIPTION	KEY NO.	PART NO.	DESCRIPTION
1	145498	Decal Read Owners Manual	14	163259	Decal Dash Panel
2	163205	Decal Fend Auto Sears Gold	15	160396	Decal Mower Drive Schematic
3	163200	Decal Hood Rh Craftsman	19	138047	Decal, Battery Diehard Sears
4	163202	Decal Hood Lh Craftsman	20	163203	Decal Deck Mower EZ3 Mulching
5	273503	Decal HP Engine	22	145005	Decal Battery
6	126187X	Decal Cert DBA	--	162598	Decal Drawbar Load Limit
7	140837	Decal Brake Parking LT	--	138311	Decal Lift Handle
8	159736	Decal Chassis Hot Muffler	--	142341	Decal, Drawbar Cntrl. Mvt. Hyd. Lt.
9	163204	Decal Fender Craftsman Gold	--	154515	Pad Footrest Lh STLT
10	145437	Decal Europe Stand CE	--	154516	Pad Footrest Rh STLT
11	145494	Decal Inter Cuttinger	--	164290	Manual, Owner's (Euro)
12	159737	Decal Brake/Clutch Sym LT	--	164291	Manual, Owner's (Scan)
13	146046	Decal V-belt Dr Sch Tractor E			

WHEELS & TIRES

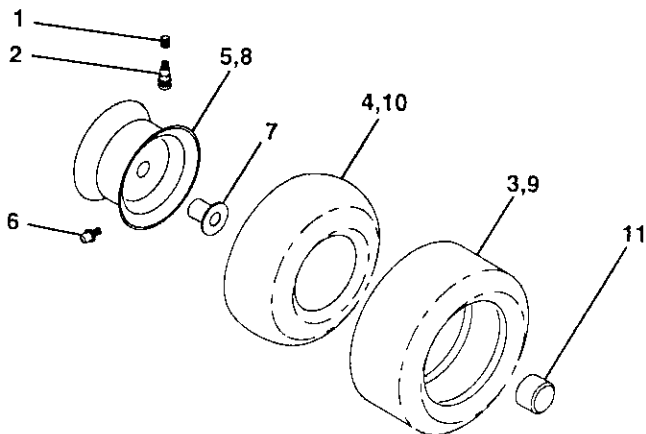

KEY NO.	PART NO.	DESCRIPTION
1	59192	Valve Cap, Tire
2	65139	Stem, Valve
3	106222X	Tire, Front
4	59904	Tube, Front Tire (Not Provided, Service Item Only)
5	106732X427	Rim, Front
6	278H	Fitting, Grease (Front Wheel Only)
7	9040H	Bearing, Flange (Front Wheel Only)
8	106108X427	Rim, Rear
9	122082X	Tire, Rear
10	7152J	Tube, Rear Tire (Not Provided, Service Item Only)
11	104757X	Cap, Axle
--	144334	Sealant, Tire (10 oz. Tube)

NOTE: All component dimensions given in U. S. inches
1 inch = 25.4 mm

REPAIR PARTS

TRACTOR - - MODEL NUMBER 917.258330

ENGINE

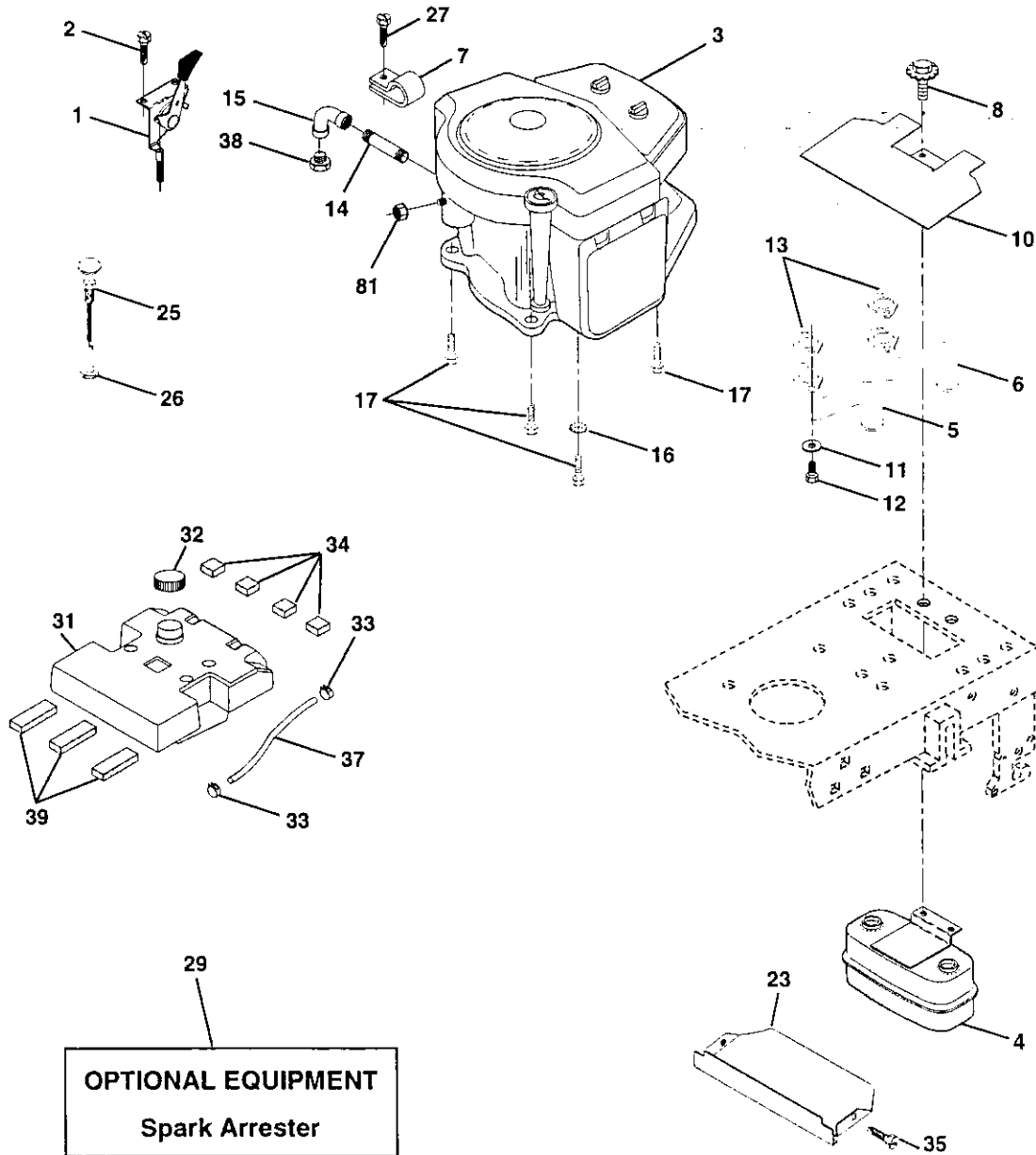

KEY NO.	PART NO.	DESCRIPTION
1	162152	Control Throt Paddle 32 22
2	17720410	Screw Hex Thd Cut 1/4-20x5/8 T
3	-----	Engine (See Breakdown) Briggs Model No. 42E707-2631-E1
4	149723	Muffler Exhaust
5	144069	Exhaust Asm. Left
6	144068	Exhaust Asm. Right
7	138129	Clamp Tube Double Engine
8	150176	Bolt 5/16 - 18 UNC X 3/4 W/Sems
10	145552	Heat Shield Lt
11	STD551125	Washer Lock Hvy. Helical 1/4
12	STD522507	Bolt Fin Hex 1/4-20 x 3/4
13	272250	Gasket Muffler
14	13280336	Nipple Pipe 4-1/2"

KEY NO.	PART NO.	DESCRIPTION
15	13200300	Elbow Std 90 Degree 3/8-18 Npt
16	STD551237	Washer Lock Ext Tooth 3/8
17	17490624	Screw Thdrol 3/8-16x1-1/2 Tytt
23	159880	Shield Browning/Debris Guard
25	145996	Control Choke
26	73920600	Nut Keps 3/8-24 Unf
27	152927	Screw TT #10-32 x 5 x 3/8 Flange
29	137180	Arrestor Spark
31	157103	Tank Fuel 3 50 Rear
32	161696	Cap Fuel Gauge STLTL
33	123487X	Clamp Hose Blk
34	106082X	Spacer Pad

NOTE: All component dimensions given in U.S. inches
1 inch = 25.4 mm

REPAIR PARTS

TRACTOR - - MODEL NUMBER 917.258330

MOWER LIFT

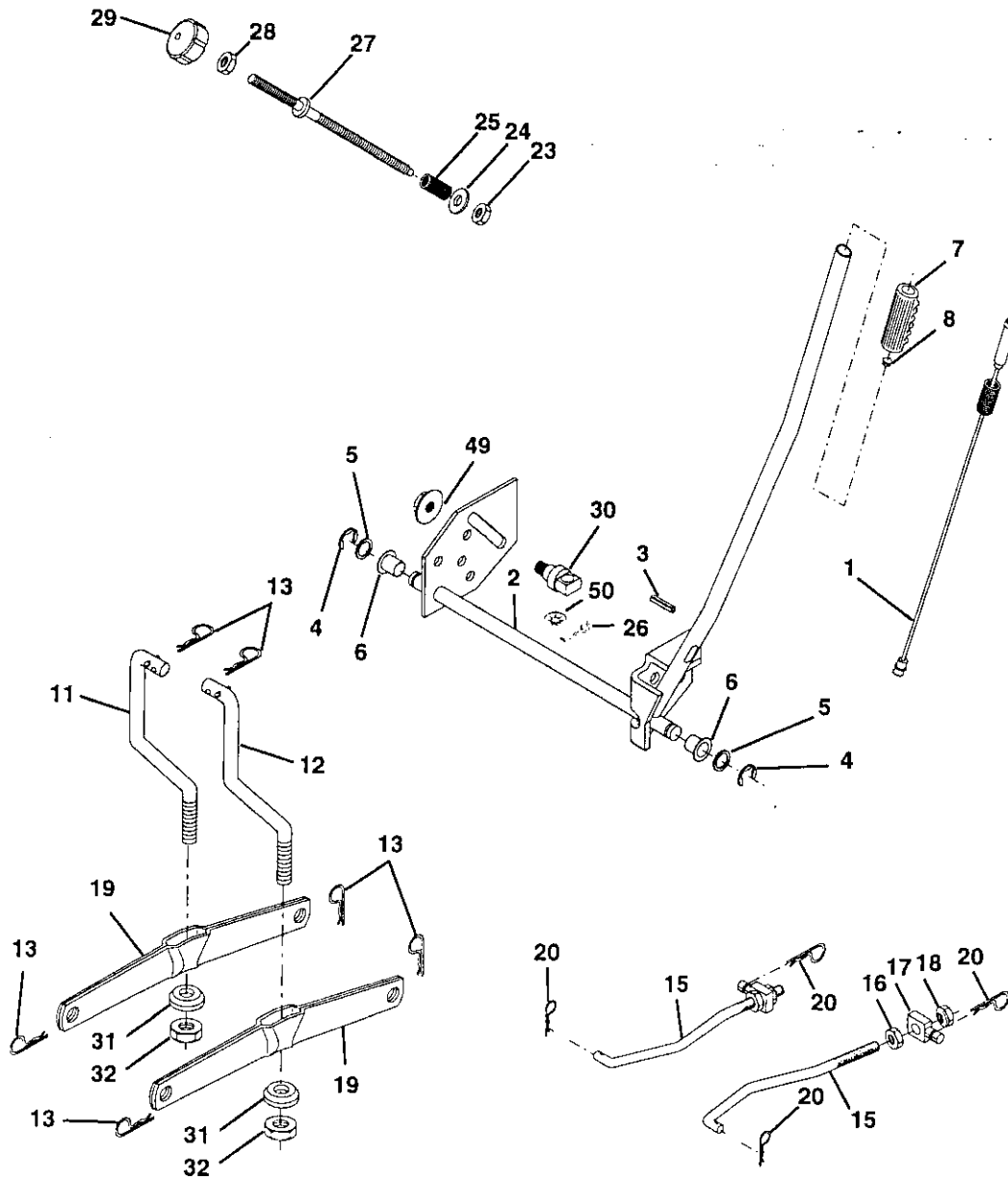

KEY NO.	PART NO.	DESCRIPTION
1	159460	Wire Assy., Inner/Spring, w/Plunger
2	159471	Shaft Asm. Lift
3	105767X	Pin Groove
4	12000002	E Ring #5133-62
5	19211621	Washer 21/32 x 1 x 21 Ga.
6	120183X	Bearing Nylon
7	125631X	Grip Handle Fluted
8	122365X	Button Plunger Read
11	139865	Link Lift Lh Fixed Length
12	139866	Link Lift Rh Fixed Length
13	STD624008	Retainer Spring
15	127218	Link Front
16	73350800	Nut Jam Hex 1/2-13 Unc
17	130171	Trunnion Blk Zinc
18	73800800	Nut Lock W/Wsh 1/2-13 Unc

KEY NO.	PART NO.	DESCRIPTION
19	139868	Arm Suspension Rear
20	163552	Retainer Spring
23	110807X	Nut Special
24	19131016	Washer 13/32 x 5/8 x 16 Ga.
25	2876H	Spring 2-1/8"
26	76020308	Pin cotter 3/32 x 1/2
27	126971X	Rod Adj. Lift
28	73350600	Nut Hex Jam 3/8-16
29	138057	Knob Inf. 3/8-16
30	150233	Trunnion Infin. Height
31	140302	Bearing, Pivot, Lift, Special
32	73540600	Nut, Crownlock 3/8-24
49	145212	Nut Flange Lock
50	110452X	Nut Push Phos & Oil

NOTE: All component dimensions given in U.S. inches
1 inch = 25.4 mm

REPAIR PARTS

TRACTOR - - MODEL NUMBER 917.258330

MOWER DECK

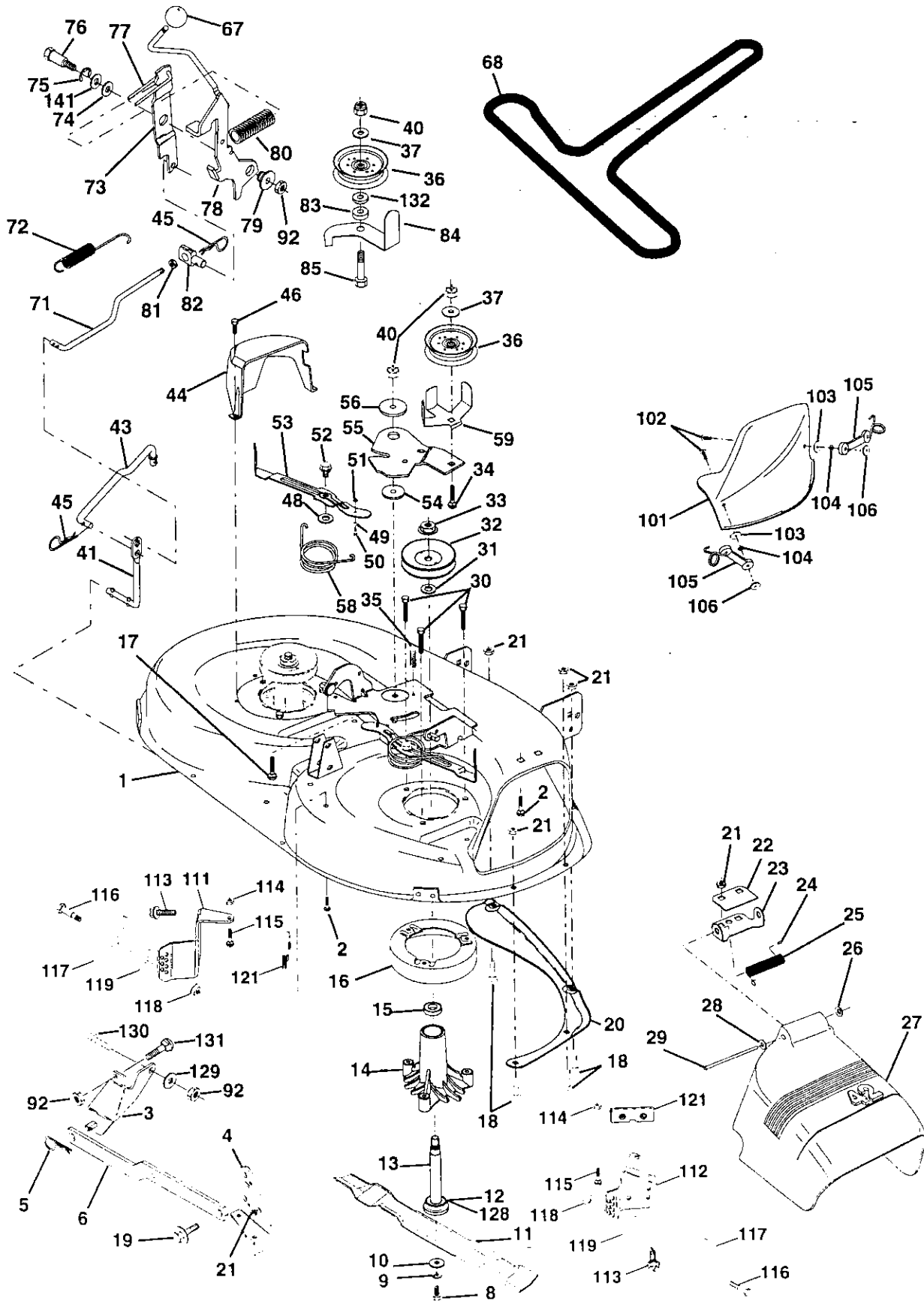

REPAIR PARTS

TRACTOR - - MODEL NUMBER 917.258330

MOWER DECK

KEY NO.	PART NO.	DESCRIPTION	KEY NO.	PART NO.	DESCRIPTION
1	144393	Mower Housing	58	140086	Spring, Torsion Brakes
2	STD533107	Bolt	59	141043	Guard, TUV Idler
3	138017	Bracket Assembly, Sway Bar, Front	67	162113	Knob Custom Oval
4	138440	Bracket Assembly, Sway Bar	68	144200	V-Belt
5	STD624008	Retainer Spring	71	142427	Rod, Clutch, Primary, with Nibs
6	130832	Arm, Suspension, Rear	72	131870	Spring, Return
8	850857	Bolt, Hex 3/8-24 x 1.25 Grade 8	73	127847	Arm, Clutch, Secondary
9	STD551137	Washer, Lock	74	121748X	Washer 25/32 x 1-5/8 x 16 Gauge
10	140296	Washer, Hardened	75	12000029	Ring, Klip
11	134149	Blade, Mulching	76	128903	Bolt, Shoulder 3/8-16 UNC x 1.44
12	129895	Bearing, Ball	77	127845	Keeper, Spring
13	137645	Shaft Assembly, Mandrel, Vented (Includes Key Number 6)	78	160570	Lever Asm. Clutch Pri Plm STLT
14	128774	Housing, Mandrel, Vented	79	127498	Bushing, Large, Brass
15	110485X	Bearing, Ball, Mandrel	80	153701	Spring, Mower Clutch
16	140329	Stripper, Vented Mower Deck	81	73350600	Nut, Hex Jam 3/8-16 Unc
17	72110610	Bolt, Carriage 3/8-16 x 1-1/4	82	142028	Trunnion, Adj.
18	72140505	Bolt, Carriage 5/16-18 x 5/8	83	120958X	Washer Sintered
19	132827	Bolt, Shoulder	84	156084	Keeper, Belt
20	159770	Baffle, Vortex	85	72140618	Bolt, Carriage 3/8-16 x 2-1/4
21	STD541431	Nut Crownlock 5/16-18 UNC	92	STD541437	Nut
22	134753	Stiffener Bracket	101	136420	Mulcher Cover
23	131267	Bracket, Deflector	102	71161010	Screw
24	105304X	Cap, Sleeve	103	19061216	Washer #10
25	123713X	Spring, Torsion, Deflector	104	STD551110	Washer, Lock
26	110452X	Nut, Push	105	160793	Latch Assembly, Bagger
27	130968	Shield, Deflector	106	2029J	Nut, Weld
28	19111016	Washer 11/32 x 5/8 x 16 Gauge	111	155197	Bracket, Gauge, Wheel L.H.
29	131491	Rod, Hinge	112	155198	Bracket, Gauge, Wheel R.H.
30	157722	Screw Thd Rolling Washer Head	113	17490512	Screw Thdrol 5/16-18 x 3/4
31	129963	Washer, Spacer	114	73510500	Nut, Hex, Keps 5/16-18 UNC
32	153535	Pulley, Mandrel	115	72110504	Bolt, Carriage 5/16 UNC x 1/2
33	137266	Nut, Toplock, Flanged	116	137644	Bolt, Shoulder
34	STD533717	Bolt	117	133957	Wheel, Gauge
35	133835	Fastner, Christmas Tree	118	73930600	Nut, Centerlock 3/8-16
36	131494	Pulley, Idler, Flat	119	19121414	Washer 3/8 x 7/8 x 14 Gauge
37	19131316	Washer 13/32 x 13/16 x 16 Gauge	121	143723	Bracket
40	STD541437	Nut Crownlock 3/8-16 UNC	128	153390	Washer Felt
41	133551	Rod, Pivot, with Nibs	129	19131312	Washer 13/32 x 13/16 x 12 Ga.
43	140083	Rod, Clutch, Secondary, with Nibs	130	STD523710	Bolt, Fin Hex 3/8-16 UNC x 1 Gr. 5
44	140088	Guard, Mandrel, L.H.	131	STD533710	Bolt, RDHD SQNK 3/8-16 UNC x 1
45	STD624003	Retainer	132	19132203	Washer 13/32 x 1-3/8 x 3 Ga.
46	137729	Screw, Thd. Roll 1/4-20 x 5/8	141	6266H	Washer Thrust .75 x 1.230
48	133944	Washer, Hardened	--	130794	Mandrel Assembly (Includes Key Numbers 8-10, 12-15, 31 and 32)
49	155066	Roller Assembly, Cam Follower	--	145411	Mower Deck, Complete (Standard Deck, Order Separately Mulcher Plate and Gauge Wheel Components, Key Nos. 101-106 and 111-121)
50	131340	Bolt, Shoulder #10-24 Grade 5			
51	STD541410	Locknut			
52	139888	Bolt, Shoulder 5/16-18 UNC			
53	131845	Arm Assembly, Pad, Brake			
54	133943	Washer, Hardened			
55	155046	Arm, Idler			
56	122052X	Spacer, Retainer			

NOTE: All component dimensions given in U.S. inches
1 inch = 25.4 mm

REPAIR PARTS

TRACTOR - - MODEL NUMBER 917.258330

HYDRO GEAR TRANSAXLE - MODEL NUMBER 310-0650

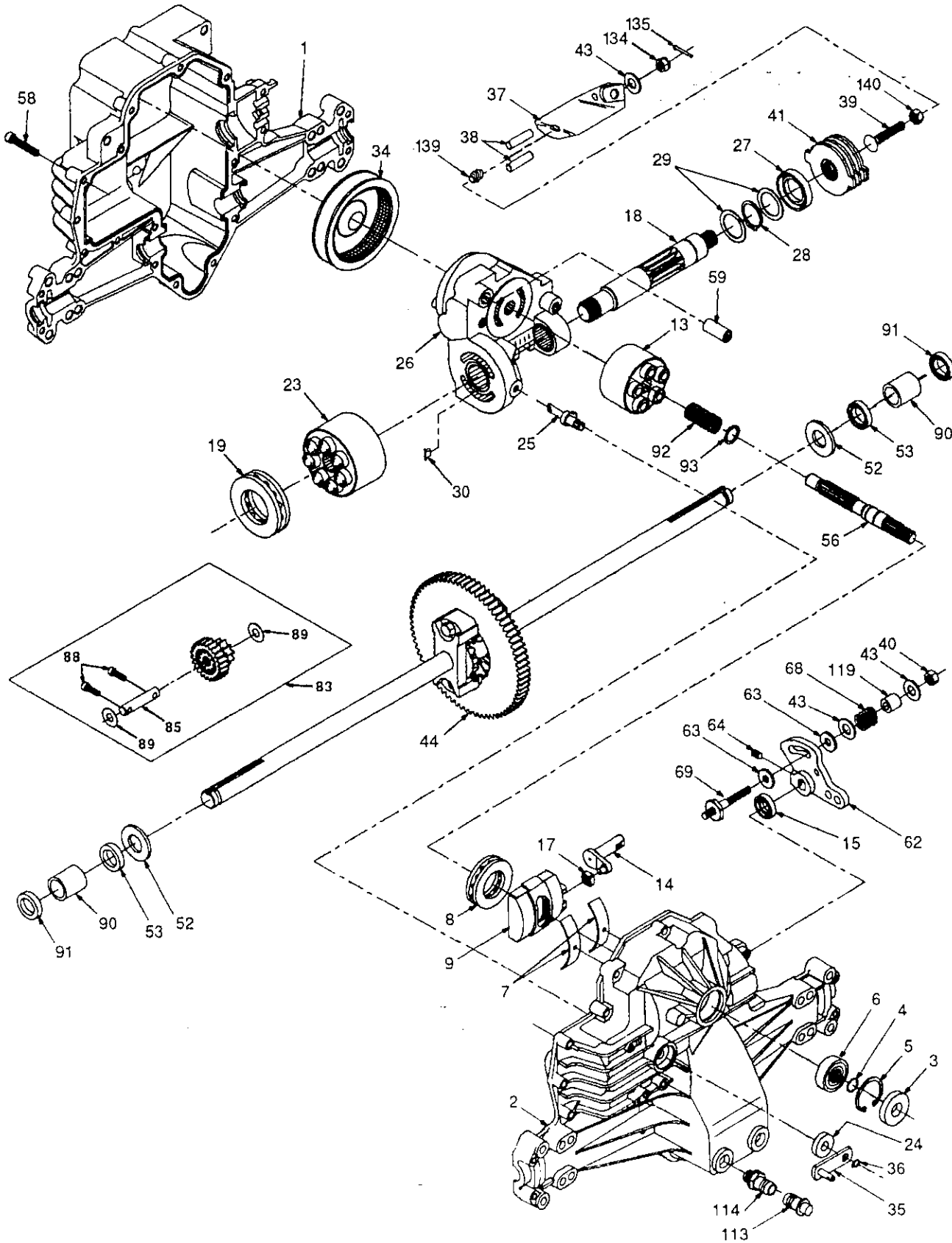

REPAIR PARTS

TRACTOR - - MODEL NUMBER 917.258330

HYDRO GEAR TRANSAXLE - MODEL NUMBER 310-0650

KEY PART NO. NO.	DESCRIPTION	KEY PART NO. NO.	DESCRIPTION
1 142930	Housing, Lower	43 142884	Washer 7/16 x 7/8 x .060
2 142931	Assembly, Upper Housing	44 150829	Differential Assembly
3 142932	Seal, Lip	52 142991	Washer 3/4 x 1.5 x .13
4 142928	Ring, Wire Retaining	53 142961	Seal .75 x 1.25 x .250
5 142933	Ring, Retaining	56 142963	Shaft, Input
6 142934	Bearing, Shaft Ball	58 142964	Bolt 1/4-20 x 1.38
7 142935	Bearing, Cradle	59 142965	Pin .5 OD x .43 ID x .750
8 150771	Bearing, Thrust 30 x 52 x 13	62 142966	Arm, Control
9 142937	Swashplate, Variable	63 142967	Puck, Dampener
13 142938	Block, Cylinder Assembly	64 142920	Set Screw
14 142939	Arm, Trunnion	68 142969	Spring
15 142940	Seal, Lip	69 144610	Stud 5/16-24
17 142941	Guide, Slot	83 142971	Jackshaft Assembly
18 150772	Shaft, Motor	85 150806	Jackshaft
19 150773	Bearing, Thrust 42 x 68 x 16	88 142973	Screw, Cap
23 142944	Block, Cylinder Assembly	89 142974	Washer 7/16 x 1 x 1/2
24 142945	Seal, Lip 10 x 25 x 7	90 142975	Sleeve Bearing
25 142946	Actuator, Bypass	91 142976	Seal, Wiper
26 150774	Center Section Assembly Kit	92 142977	Spring, Block
27 142948	Seal, Lip 26 x 42 x 8	93 142978	Washer, Block Thrust
28 142949	Ring, Retaining	113 142917	Cap, Vent Assembly
29 142950	Washer 26 x 35 x 1	114 142918	Fitting, O-Ring Assembly
30 150787	Plate, Bypass	119 142980	Spacer
34 142951	Oil Filter Element	134 144607	Nut, Castle 5/16-24
35 142952	Arm, Bypass	135 144608	Pin, Cotter
36 142953	Ring, Retaining	139 150775	Spring, Compression
37 142954	Arm, Actuating	140 150776	Nut, Hex 5/16-24
38 142955	Pin, Actuating		
39 150777	Bolt 5/16-24 x 1-3/4		
40 150778	Locknut, Hex 5/16-24 UNJC		
41 142958	Brake Rotor/Stator Kit		

NOTE: All component dimensions given in U.S. inches
1 inch = 25.4 mm

EPAIR PARTS

TRACTOR - - MODEL NUMBER 917.258330

RIGGS & STRATTON ENGINE - MODEL NUMBER 42E707, TYPE NUMBER 2631-E1

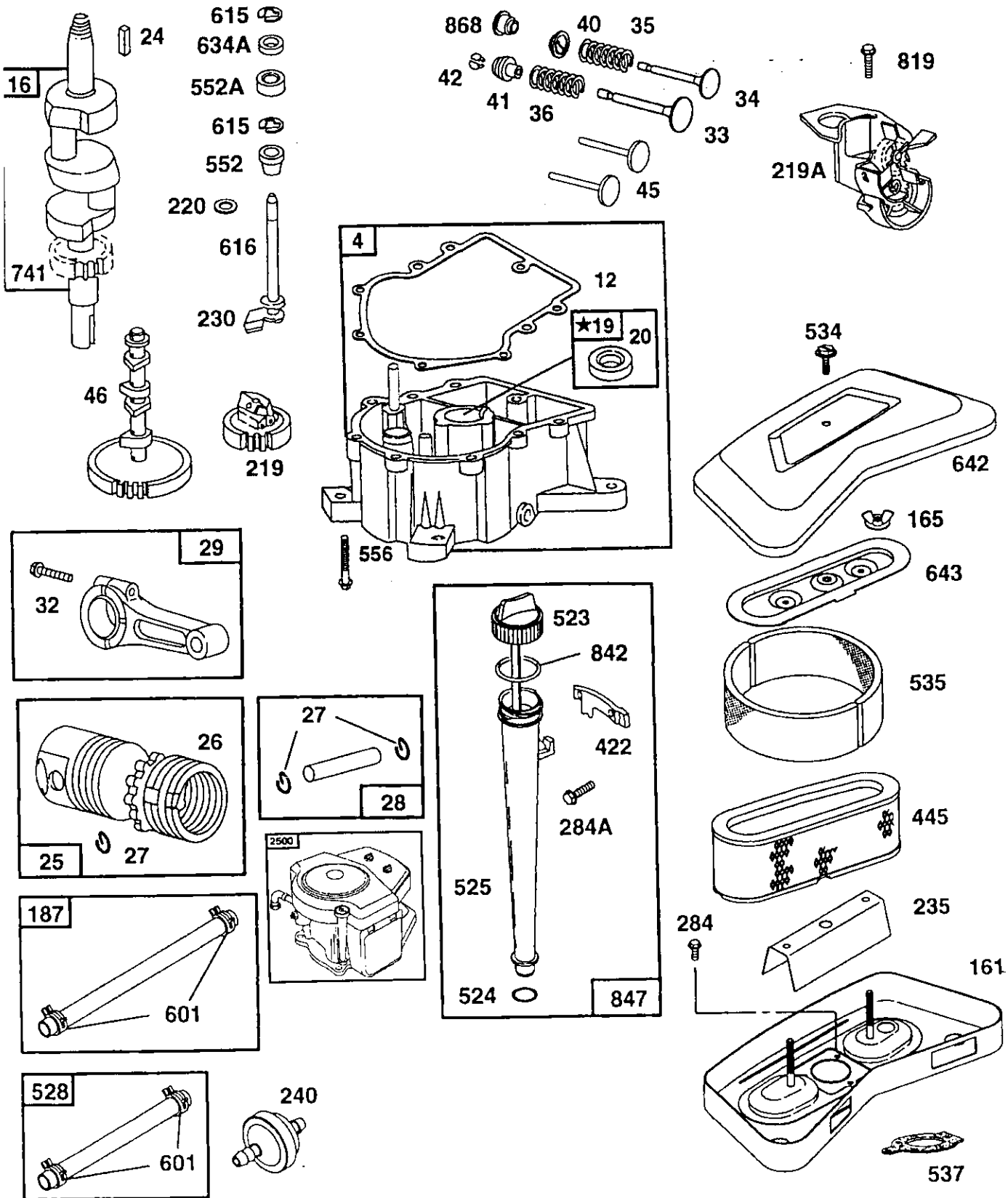

REPAIR PARTS

TRACTOR - - MODEL NUMBER 917.258330

BRIGGS & STRATTON ENGINE - MODEL NUMBER 42E707, TYPE NUMBER 2631-E1

358 GASKET SET

861 PUMP REPAIR KIT

121 CARBURETOR KIT

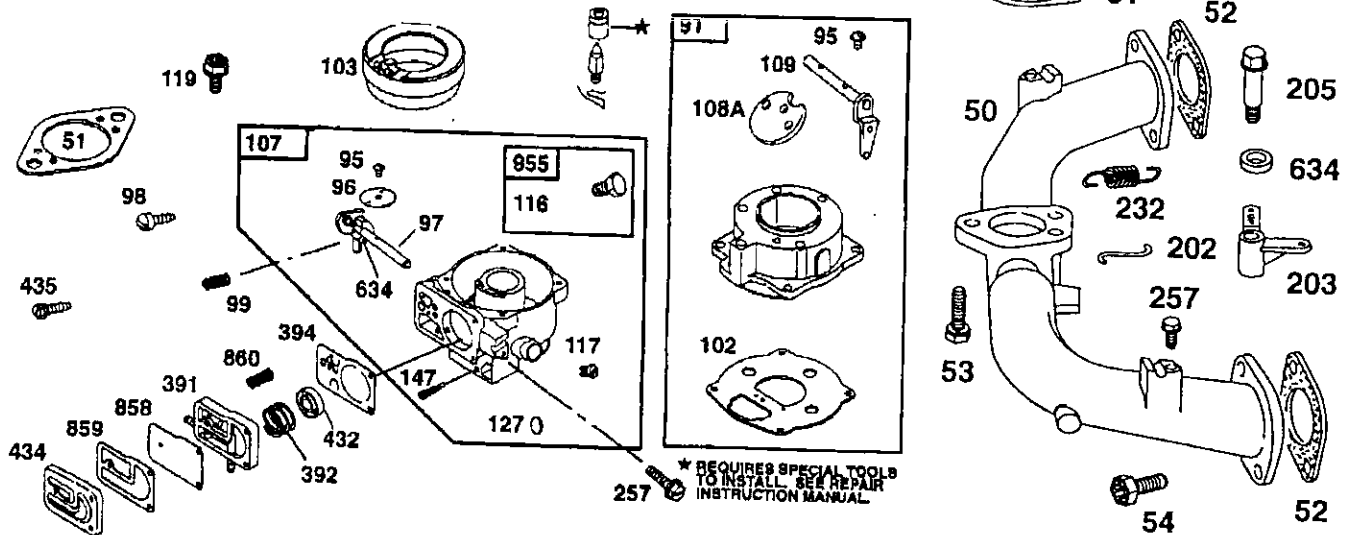

REPAIR PARTS

TRACTOR - - MODEL NUMBER 917.258330

BRIGGS & STRATTON ENGINE - MODEL NUMBER 42E707, TYPE NUMBER 2631-E1

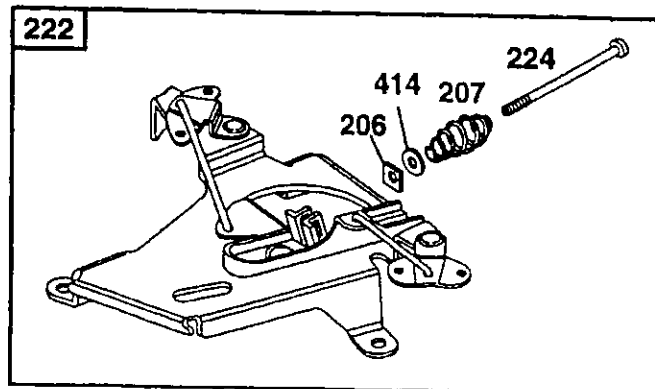
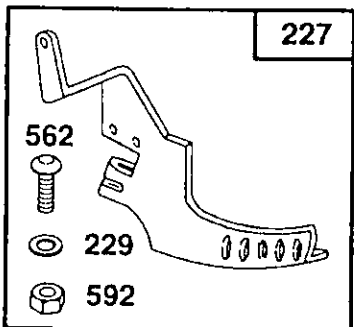
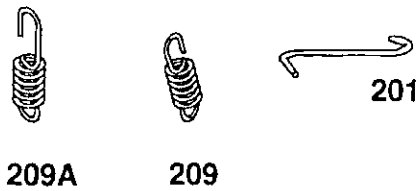
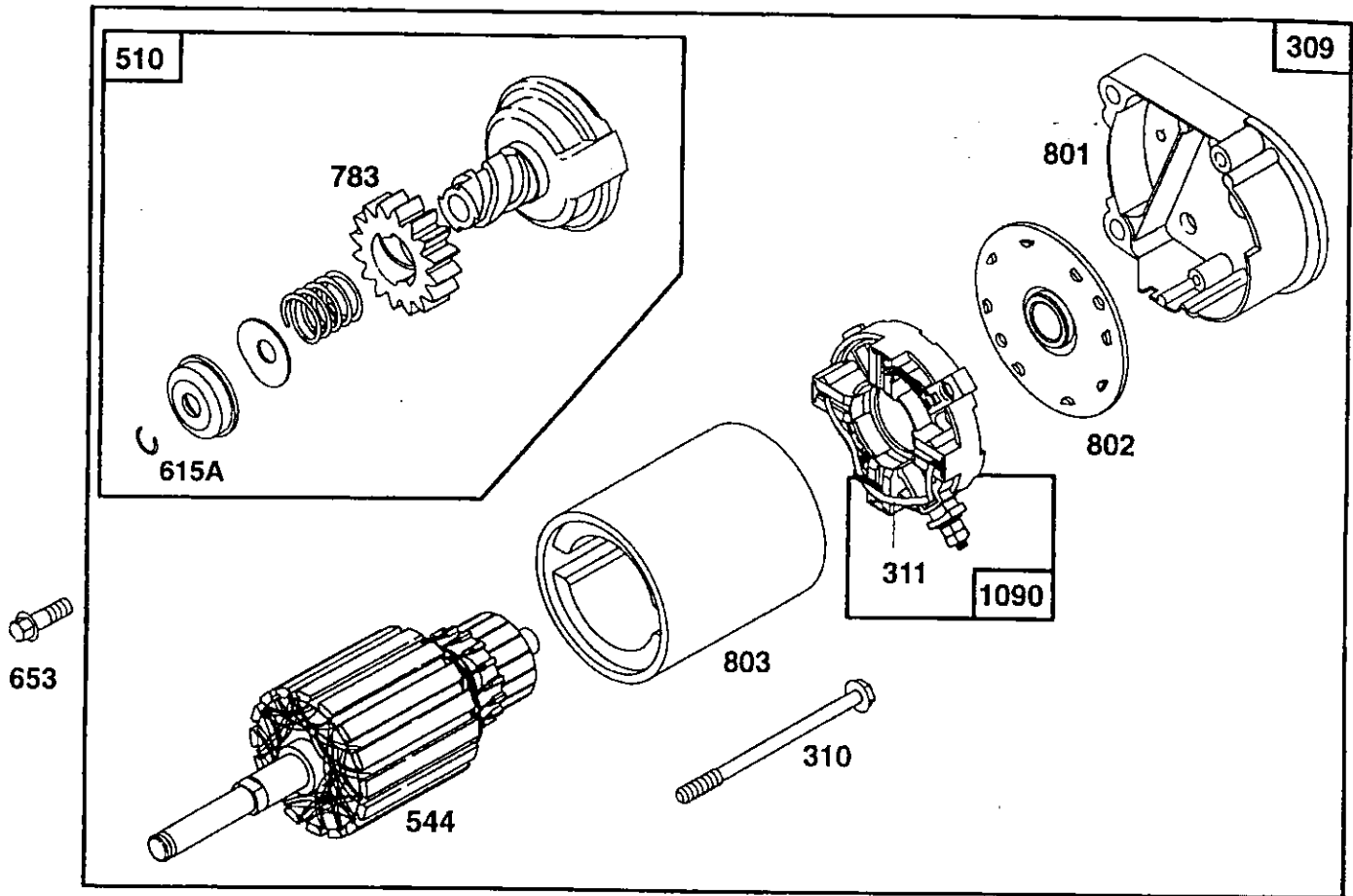

REPAIR PARTS

TRACTOR - - MODEL NUMBER 917.258330

BRIGGS & STRATTON ENGINE - MODEL NUMBER 42E707, TYPE NUMBER 2631-E1

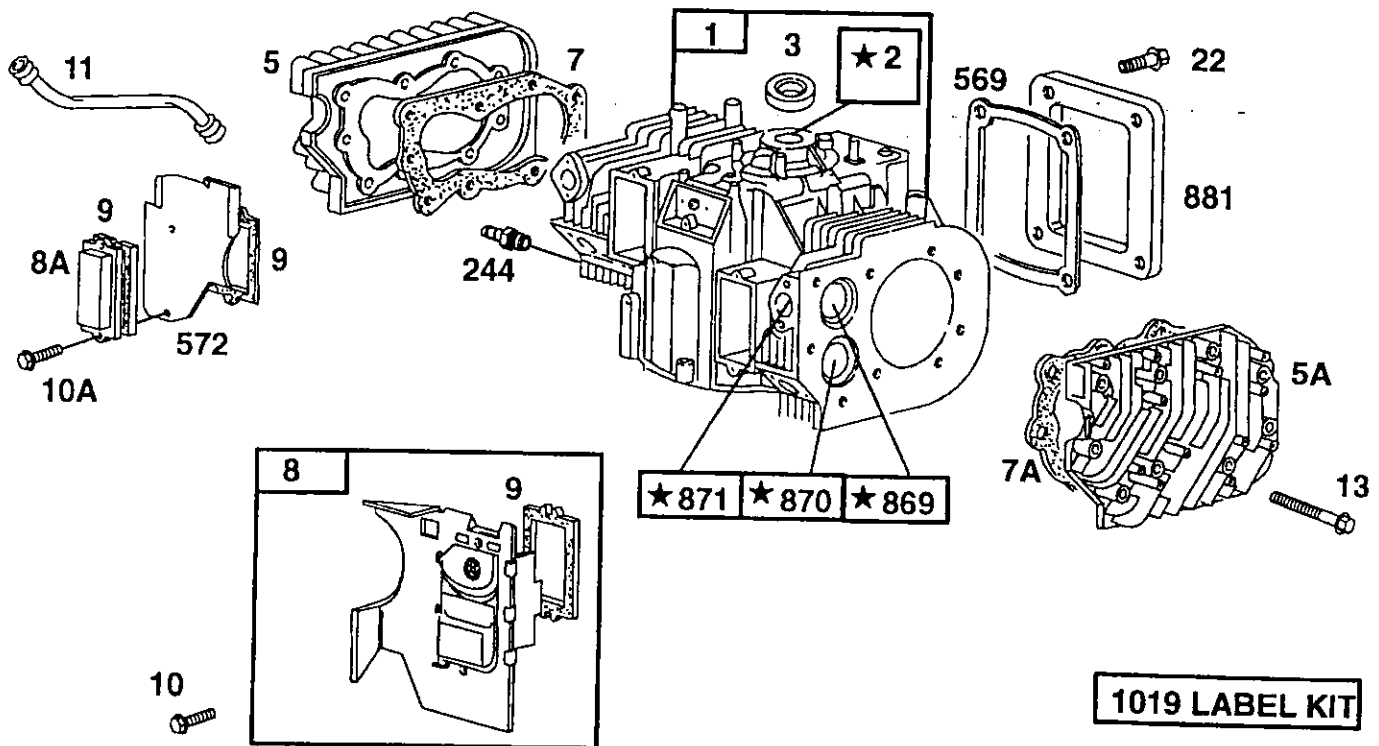

1019 LABEL KIT

★ REQUIRES SPECIAL TOOLS TO INSTALL. SEE REPAIR INSTRUCTION MANUAL.

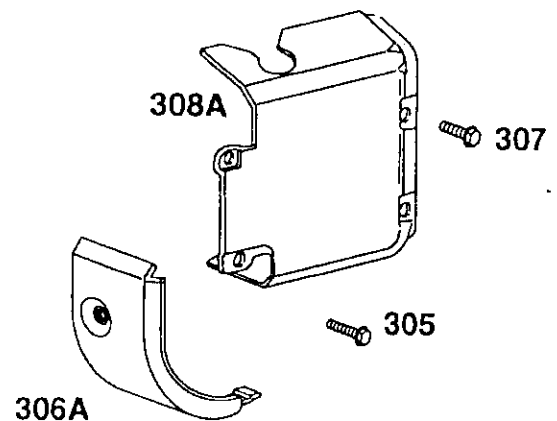
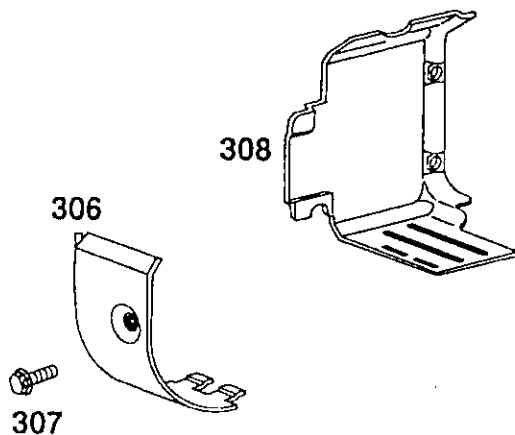
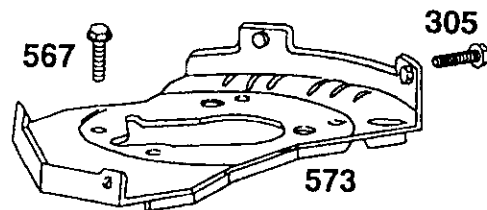
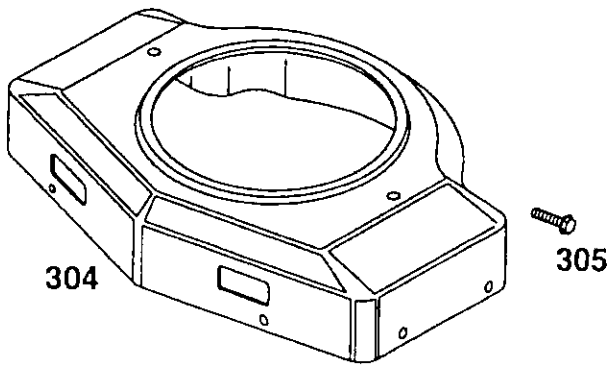

REPAIR PARTS

TRACTOR - - MODEL NUMBER 917.258330

BRIGGS & STRATTON ENGINE - MODEL NUMBER 42E707, TYPE NUMBER 2631-E1

KEY PART NO.	NO.	DESCRIPTION	KEY PART NO.	NO.	DESCRIPTION
1	497074	Cylinder Assembly	54	93208	Screw, Phillips
2	399265	Bushing	75	222511	Washer, Spring
3	391086	* Seal, Oil	78	95039	Screw, Hex
4	493304	Sump, Engine	91	499281	Body Assembly, Upper
5	493457	Head, Cylinder #1	95	93499	Screw, Sems
5A	493458	Head, Cylinder #2	96	221939	Valve, Throttle
7	271867	* Gasket, Cylinder Head #1	97	499172	Shaft, Throttle
7A	271868	* Gasket, Cylinder Head #2	98	91920	Screw, Fillister Head
8	495754	Breather Assembly #1	99	26157	Spring, Throttle Adjust
8A	222892	Cover, Breather Cylinder #2 (Used Only on Key #572, Air Baffle with Holes for Mounting)	102	271607	** Gasket, Carburetor Body
9	27803	* Gasket, Breather	103	298514	Float, Carburetor
10	94382	Screw, Sems	104	231435	** Pin, Float Hinge
10A	94830	Screw, Sems	105	394682	** Valve, Needle
11	280225	Tube, Breather	107	499655	Body Assembly, Lower
12	273208	* Gasket, Crankcase, .015" Thick	108	225373	Valve, Choke
	271188	* Gasket, Crankcase, .005" Thick	109	392673	Shaft, Choke
	271189	* Gasket, Crankcase, .009" Thick	116	280474	* O-Ring
13	94565	Screw, Cylinder Head	117	232018	Jet, Needle Valve, Fixed
15	94239	Plug, Oil Drain		232022	Jet, Needle Valve, Fixed, High Altitude
16	394028	Crankshaft	119	94152	Screw, Hex Head
	94196	Timing Gear Key	121	491539	Carburetor Kit
19	399264	Bushing	125	19306	Carburetor
20	291675	* Seal, Oil	127	223472	** Plug, Welch
22	94724	Screw, Sems	161	496599	Base, Air Cleaner
23	491180	Flywheel	165	94289	Nut, Wing
24	222698	Key, Flywheel	187	299146	Line, Fuel, 28" Long (Cut to Suit)
25	498584	Piston Assembly, Standard Size	188	94627	Screw
	498585	Piston Assembly, .010" Oversize	201	262683	Link
	498586	Piston Assembly, .020" Oversize	202	262684	Link
	498587	Piston Assembly, .030" Oversize	203	280997	Crank, Bell
26	394959	Ring Set, Standard Size	205	93971	Screw, Hex Head
	394960	Ring Set, .010" Oversize	206	94298	Nut
	394961	Ring Set, .020" Oversize	207	262337	Spring, Control, Rod
	394962	Ring Set, .030" Oversize	209	262352	Spring, Governor
27	263129	Lock, Piston Pin	209A	261563	Spring, Governor Idle
28	498319	Pin, Piston, Standard Size	219	394348	Gear, Governor
	391286	Pin, Piston, .005" Oversize	219A	393415	Oil Slinger
29	394306	Rod, Connecting, Standard Size	220	222773	Washer, Thrust
	397158	Rod, Connecting, .020" Undersize	222	491282	Bracket, Control
32	94671	Screw, Connecting Rod	224	94297	Screw, Torx®
33	390420	Valve, Exhaust			* Included in Gasket Set (495868)
34	261528	Valve, Intake			** Included in Carburetor Kit (491539)
35	65906	Spring, Valve, Intake			*** Included in Carburetor Kit (491539), and Pump Repair Kit (393397)
36	26828	Spring, Valve, Exhaust			**** Included in Gasket Set (495868), and Carburetor Kit (491539)
40	221596	Retainer, Valve, Intake			
41	292260	Retainer, Valve, Exhaust			
42	494553	Keeper, Valve			
45	261368	Tappet, Valve			
46	214484	Gear, Cam			
50	213290	Manifold, Intake			
51	271412	**** Gasket, Carburetor Mounting			
51A	281412	Spacer, Carburetor			
52	270884	* Gasket, Intake Manifold Mounting			
53	93970	Screw, Hex Head, Carburetor to Manifold			

NOTE: All component dimensions given in U.S. inches
1 inch = 25.4 mm

REPAIR PARTS

TRACTOR - - MODEL NUMBER 917.258330

BRIGGS & STRATTON ENGINE - MODEL NUMBER 42E707, TYPE NUMBER 2631-E1

KEY PART NO.	NO.	DESCRIPTION	KEY PART NO.	NO.	DESCRIPTION
227	491297	Lever Assembly, Governor	556	93585	Screw, Hex Head
229	62199	Washer	562	93853	Bolt, Governor Lever
230	223882	Washer, Governor Crank, Inside	567	94811	Screw, Hex Head, Back Plate to Cylinder
235	224995	Shield, Fuel Spray	569	272645	* Gasket, Base
240	394358	Filter, Fuel	572	224816	Baffle, Air, Cylinder #2
244	230318	Connector, Fuel Line	573	491304	Plate, Back
257	93897	Screw, Sems	592	92278	Nut, Hex.
284	94674	Screw, Hex Head	601	93053	Clamp, Hose
284A	94882	Screw, Hex Head	615	94296	Retainer, E-Ring
304	495469	Housing, Blower, Red	615A	263080	Retainer
305	94786	Screw, Sems	616	491530	Crank, Governor
306	222846	Shield, Cylinder	634	271013	** Washer, Throttle Shaft
306A	223734	Shield, Cylinder	634A	491287	* Seal, Governor Shaft
307	94930	Screw, Self-Tapping	635	66538	Boot, Spark Plug
308	224774	Cover, Air Guide	642	225008	Cover, Air Cleaner
308A	224775	Cover, Air Guide	643	496700	Plate, Air Cleaner
309	497596	Motor, Starter	653	93585	Screw, Hex Head
310	94003	Bolt, Thru	726	391362	Gear, Ring (Includes Mounting Parts)
311	497608	Brush Set	741	262989	Gear, Timing
332	230674	Nut, Hex	783	280104	Gear, Starter
333	394891	Armature, Magneto	801	394860	Cap, Drive
334	94731	Screw, Sems	802	497607	Cap, End
337	802592	Plug, Spark	803	497604	Housing, Starter
356	494705	Wire, Stop	819	94675	Screw, Hex Head
358	495868	Gasket Set	842	270920	* Seal, Cap
363	19203	Flywheel Puller	847	495715	Tube Assembly, Oil
383	89838	Wrench, Spark Plug	851	493880	Terminal, Cable
391	280197	Body, Pump	858	270989	*** Diaphragm, Carburetor
392	261395	*** Spring, Diaphragm	859	271025	*** Gasket, Pump
394	272638	*** Diaphragm, Carburetor	860	261358	*** Spring, Diaphragm
414	220680	Washer	861	393397	Repair Kit, Pump
422	222875	Bracket, Oil Fill	868	497212	Seal, Valve
432	221377	*** Cap, Spring	869	261463	Seat, Valve, Intake
434	223688	Cover, Diaphragm	870	213316	Seat, Valve, Exhaust
435	93829	Screw, Diaphragm Cover	871	261961	Bushing, Guide (Exhaust Only)
445	394019	Filter, Air		231218	Bushing, Guide (Intake, Brass)
468	497908	Screen, Rotating	877	393456	Wire, Alternator
474	393474	Alternator	881	495901	Plate, Cover
482	93621	Screw,	955	397882	Plug and Seal, Solenoid
510	497606	Drive, Starter	1005	281053	Fan, Flywheel
523	494947	Cap, Oil Fill	1006	224901	Retainer, Fan
524	271157	* Seal, Fill Tube	1019	496726	Label Kit
525	495348	Tube, Oil Fill (Includes Seals)	1090	97605	Retainer, Brush
528	393815	Hose, Vacuum	2500	42E707-2631	Replacement Engine
534	94823	Screw, Air Cleaner	— —	498543	Replacement Shortblock
535	272490	Filter, Air			
537	271411	**** Gasket, Air Cleaner			
544	497603	Armature, Starter			
552	262332	Lower Bushing, Governor			
552A	262331	Upper Bushing, Governor			

* Included in Gasket Set (495868)

** Included in Carburetor Kit (491539)

*** Included in Carburetor Kit (491539),
and Pump Repair Kit (393397)

**** Included in Gasket Set (495868),
and Carburetor Kit (491539)

NOTE: All component dimensions given in U.S. inches
1 inch = 25.4 mm

LIMITED TWO YEAR WARRANTY ON CRAFTSMAN RIDING EQUIPMENT

For two (2) years from the date of purchase, if this Craftsman Riding Equipment is maintained, lubricated and tuned up according to the instructions in the owner's manual, Sears will repair or replace, free of charge, any parts found to be defective in material or workmanship.

This Warranty does not cover:

- Expendable items which become worn during normal use, such as blades, spark plugs, air cleaners, belts, etc.
- Tire replacement or repair caused by punctures from outside objects, such as nails, thorns, stumps, or glass.
- Repairs necessary because of operator abuse, negligence, improper storage or accident or the failure to maintain the equipment according to the instructions contained in the owner's manual.
- Riding equipment used for commercial or rental purposes.

LIMITED 90 DAY WARRANTY ON BATTERY

For ninety (90) days from date of purchase, if any battery included with this riding equipment proves defective in material or workmanship and our testing determines the battery will not hold a charge, Sears will replace the battery at no charge.

IN-HOME WARRANTY SERVICE ON YOUR CRAFTSMAN RIDING EQUIPMENT IS AVAILABLE AT NO-CHARGE FOR 30 DAYS FROM THE DATE OF PURCHASE. PLEASE CONTACT YOUR NEAREST SERVICE CENTER. AFTER 30 DAYS FROM THE DATE OF PURCHASE, WARRANTY SERVICE IS AVAILABLE BY TAKING YOUR CRAFTSMAN RIDING EQUIPMENT TO YOUR NEAREST SEARS SERVICE CENTER. (IN-HOME WARRANTY SERVICE WILL STILL BE AVAILABLE AFTER 30 DAYS FROM THE DATE OF PURCHASE BUT A STANDARD TRIP CHARGE WILL APPLY.) THIS WARRANTY APPLIES ONLY WHILE THIS PRODUCT IS IN THE UNITED STATES.

This Warranty gives you specific legal rights, and you may also have other rights which may vary from state to state.

SEARS, ROEBUCK AND CO., D/817 WA, HOFFMAN ESTATES, IL 60179

CRAFTSMAN®