

REPAIR PARTS MANUAL

MODEL NO. 259040

Lawn Tractor

CRAFTSMAN®

HOW TO USE THIS MANUAL

This manual is designed to provide the customer with a means to identify the parts on his/her tractor when ordering repair parts. The illustrations may or may not represent the actual assemblies; therefore, it is not recommended to use this manual as a guide to assemble or disassemble the tractor. Some hardware and parts are drawn larger in order to more readily identify them.

Each tractor has its own model number.

The model number for your tractor can be found on the fender under the seat.

When ordering parts, always give the following information:

- Product - "Tractor"
- Model Number - "259040"
- Part Number
- Part Description

TABLE OF CONTENTS

SCHEMATIC.....	3
ELECTRICAL.....	4-5
CHASSIS	6-7
DRIVE	8-9
STEERING	10-11
SEAT.....	12
DECALS	13
ENGINE	14-15
MOWER LIFT	16-17
MOWER DECK	18-19
TRANSAXLE	20-21
ENGINE BREAKDOWN	22-27

TRACTOR- -MODEL NO. 917. 259040

SCHEMATIC

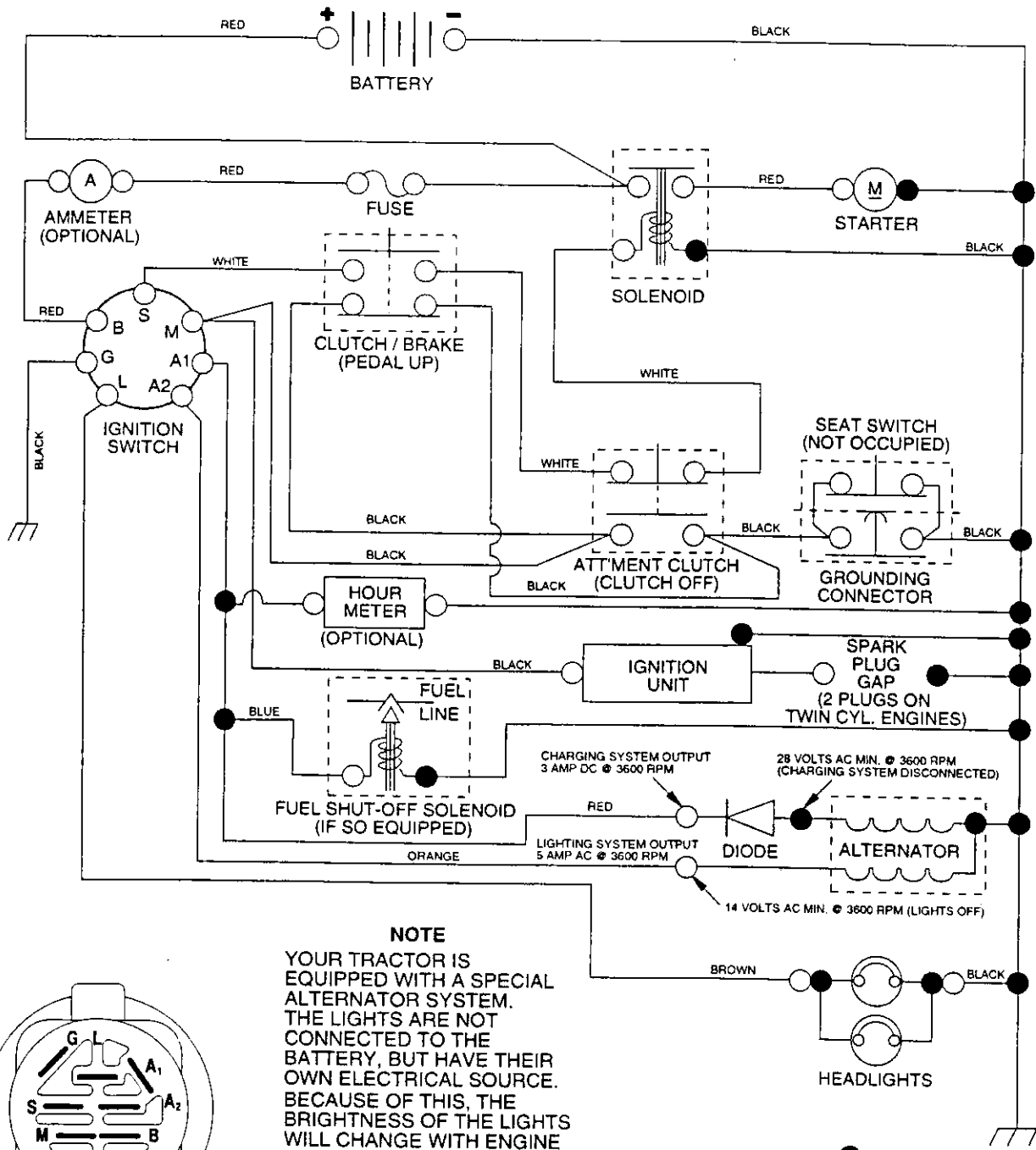

NOTE

YOUR TRACTOR IS EQUIPPED WITH A SPECIAL ALTERNATOR SYSTEM. THE LIGHTS ARE NOT CONNECTED TO THE BATTERY, BUT HAVE THEIR OWN ELECTRICAL SOURCE. BECAUSE OF THIS, THE BRIGHTNESS OF THE LIGHTS WILL CHANGE WITH ENGINE SPEED. AT IDLE THE LIGHTS WILL DIM. AS THE ENGINE IS SPEEDED UP, THE LIGHTS WILL BECOME THEIR BRIGHTEST.

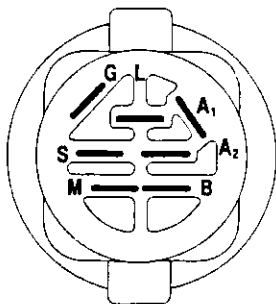

IGNITION SWITCH

POSITION	CIRCUIT	"MAKE"
OFF	M+G+A1	NONE
RUN/LIGHT	B+A1	A2+L
RUN	B+A1	NONE
START	B + S + A1	NONE

WIRING INSULATED CLIPS

NOTE: IF WIRING INSULATED CLIPS WERE REMOVED FOR SERVICING OF UNIT, THEY SHOULD BE REPLACED TO PROPERLY SECURE YOUR WIRING.

NON-REMOVABLE CONNECTIONS

REMOVABLE CONNECTIONS

REPAIR PARTS

TRACTOR- -MODEL NO. 917. 259040

ELECTRICAL

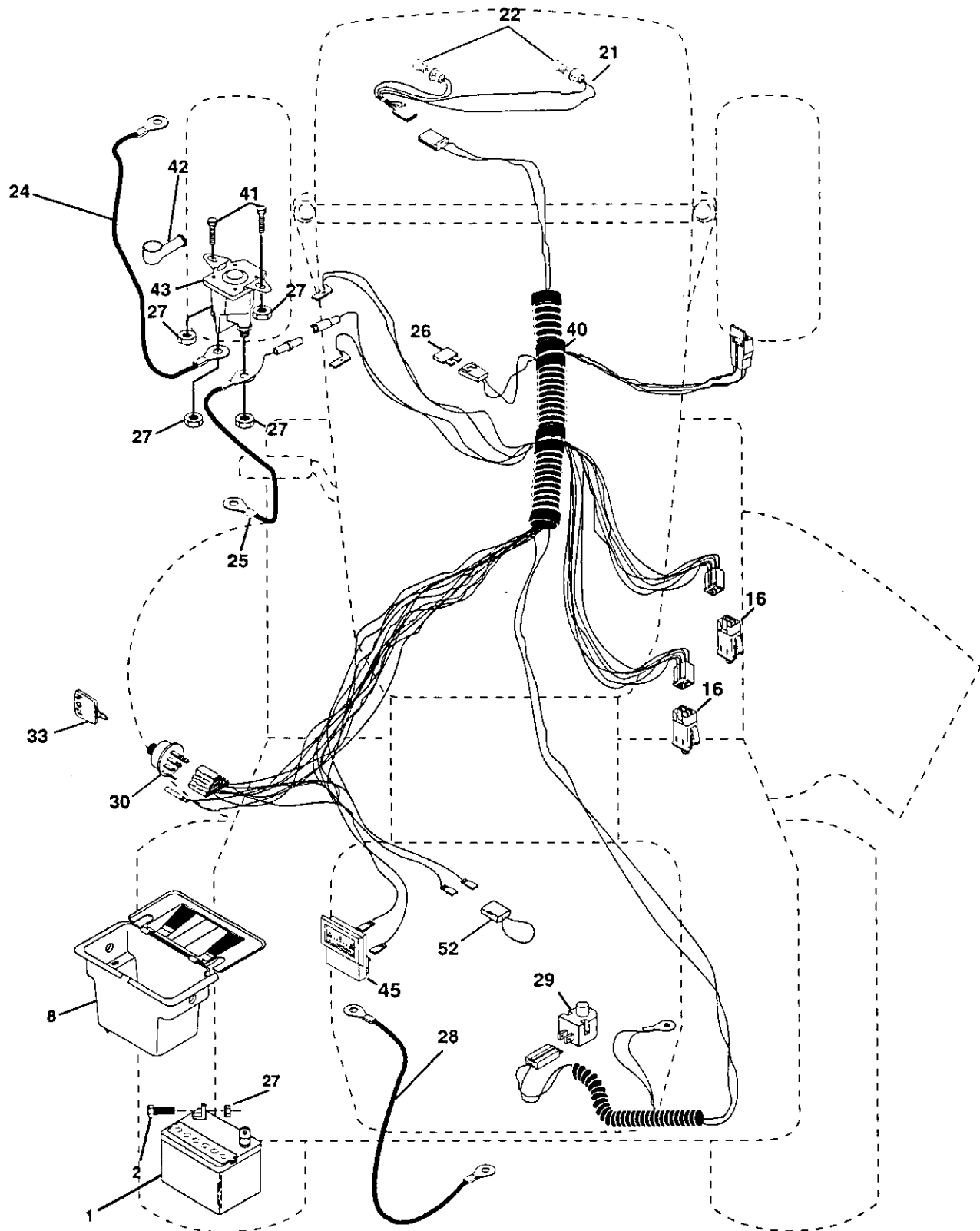

REPAIR PARTS

TRACTOR- -MODEL NO. 917. 259040

ELECTRICAL

KEY NO.	PART NO.	DESCRIPTION
1	144925	Battery
2	74760412	Bolt Hex Hd 1/4-20unc X 3/4
8	156417	Case Battery
16	153664	Switch Interlock Push-In
21	166181	Harness Socket Light W/4152J
22	4152J	Bulb Light #1156
24	4799J	Cable Battery 6ga 11" red
25	146147	Cable Battery 6 Ga W/16 Wir red
26	166180	Fuse 15 AMP
27	73510400	Nut Keps Hex 1/4-20 Unc
28	4207J	Cable Ground 6ga 12" black
29	121305X	Switch Plunger Nc Gray
30	163968	Switch Ign
33	140403	Key Ign
40	170217	Harness Ign
41	71110408	Bolt Blk Hex 1/4-20unc x 1/2
42	131563	Cover Terminal Red
43	145673	Solenoid
48	140844	Adapter Ammeter Rectangular
52	141940	Protection Wire Loop

NOTE: All component dimensions given in U.S. inches
1 inch = 25.4 mm

REPAIR PARTS

TRACTOR- -MODEL NO. 917. 259040

CHASSIS AND ENCLOSURES

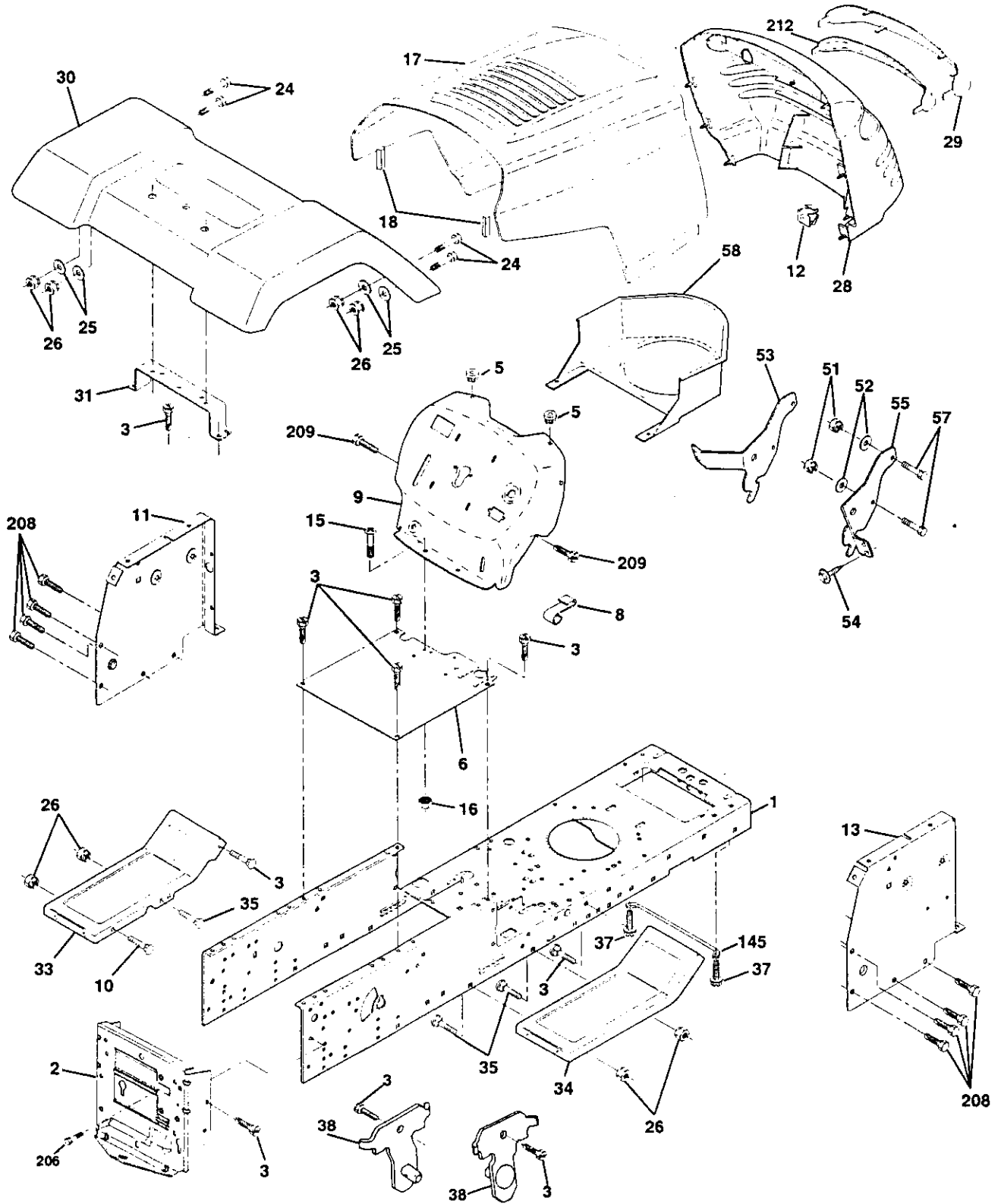

REPAIR PARTS

TRACTOR- -MODEL NO. 917. 259040

CHASSIS AND ENCLOSURES

KEY NO.	PART NO.	DESCRIPTION
1	169831	Chassis Lt Stamping
2	169061	Drawbar
3	17060612	Screw 3/8-16 x 3/4
5	155272	BumperHood/Dash
6	155924X011	Saddle SLKSCRE FLT SDL
8	155138	Clip Retainer Slide-on
9	168347X011	Dash Slkscr Plm Mech Sym
10	72140608	Bolt RdHd Sqnk. 3/8-16 x 1
11	155927	Panel Asm. Dash Lh
12	145660	Clip Tinnerman Grille P/L
13	172107X010	Panel Dash Rh
15	74180512	Screw Mach Trhd 5/16-18unc x 3/4
16	73510500	Nu Keps 5/16-18unc
17	159639X558	Hood Pnt Steel Private Label
18	126938X	BumperHood
24	74780616	Bolt Fin Hex 3/8-16 Unc x 1 Gr. 5
25	19131312	Washer 13/32 x 13/16 x 12 Ga.
26	73800600	Nut Lock Hex w/Ins 3/8-16 Unc
28	150407	Grill
29	150209X599	Lens Grille
30	169465X558	Fender Pnt
31	136619	Bracket Fender Support
33	105476X558	Footrest Pnt. Lh
34	105475X558	Footrest Pnt. Rh
35	72110606	Bolt RdHd Sht. Sqnk. 3/8-16 x 3/4
37	17490508	Screw Thdrol 5/16-18 x 1/2 Tyt
38	169834	Bracket Asm. Pivot Mower Rear
51	73800400	Nut Lock Hex W/Ins. 1/4-20
52	19091416	Washer 9/32 x 7/8 x 16 Ga.
53	144697	Bracket Grille LH
54	161464	Screw Hex Wshd #8-18 x 7/8
55	144696	Bracket, Grille RH
57	74780412	Bolt Fin Hex 1/4-20 x 3/4
58	150127	Duct Air Engine
145	156524	Rod Pivot Chassis /Hood
206	170165	Bolt Shoulder 5/16-18 TT
208	17670608	Screw Thdrol 3/8-16 x 1/2
209	17000612	Screw Hex Wsh Thdrol 3/8-16 BL
212	156494	Insert Lens
--	5479J	Plug Button Blk .359 Dia. Choke

NOTE: All component dimensions given in U.S. inches
1 inch = 25.4 mm

REPAIR PARTS

TRACTOR- -MODEL NO. 917.259040

DRIVE

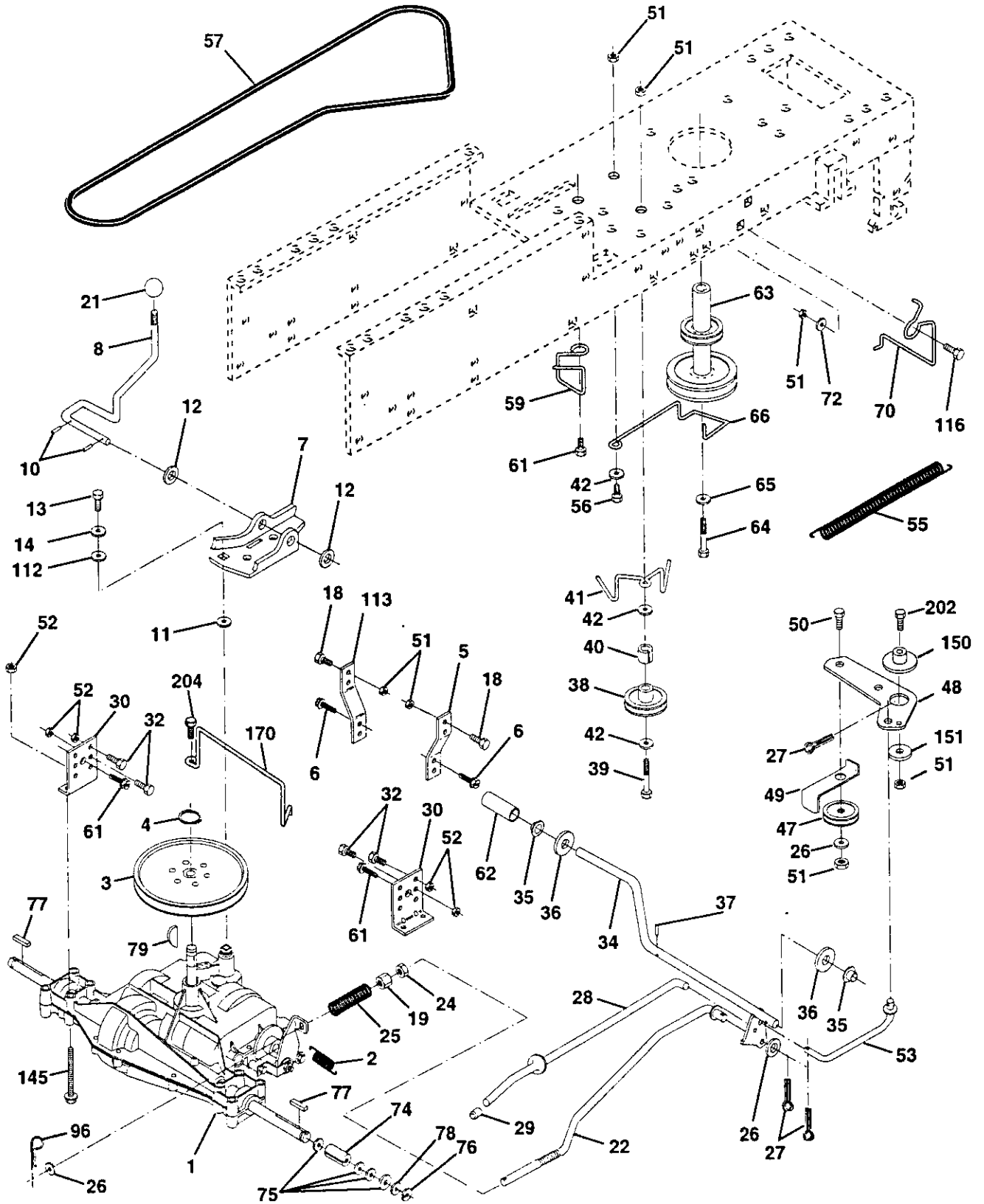

REPAIR PARTS

TRACTOR- -MODEL NO. 917.259040

DRIVE

KEY NO.	PART NO.	DESCRIPTION	KEY NO.	PART NO.	DESCRIPTION
1	----	Transaxle Peerless 205-544C (See Breakdown)	49	123205X	Retainer Belt Style Spring
2	146682	Spring Return Brake T/a Zinc	50	74760624	Bolt Hex Hd 3/8-16uncx1-1/2
3	123666X	Pulley Transaxle 18/20" tires	51	73680600	Nut Crownlock 3/8-16-UNC
4	12000028	Ring Retainer # 5100-62	52	73680500	Nut Lock 5/16-18
5	121520X	Strap Torque 30 Degrees	53	105710X	Link Clutch 7 66
6	17060512	Screw 5/16-18 x 3/4	55	105709X	Spring Return Clutch 6 75
7	162240	Bracket Saddle Shift T/a	56	74760620	Bolt Fin Hex 3/8-16 uncx1-1/4
8	131679	Rod Shf Sdl LY/YT Str Blk	57	130801	V-Belt Gd Drive
10	76020416	Pin Cotter 1/8 x 1 Cad	59	169691	Keeper Belt Center Span
11	105701X	Washer Plate Shf	61	17060612	Screw 3/8-16 x 3/4
12	19151216	Washer 15/32 x 3/4 x 16ga	62	8883R	Cover Pedal Blk Round
13	74550412	Bolt 1/4-28unf Gr8 W/Patch	63	140186	Pulley Engine
14	10040400	Washer Lock Hvy Helical 1/4	64	71170764	Bolt Hex 7/16-20 x 4 Gr 5
18	74780616	Bolt Fin Hex 3/8-16 x 1 Gr.5	65	10040700	Washer Lock Hvy Hlcl Spr 7/16
19	73800600	Nut Lock 3/8-16 Unc	66	154778	Keeper Belt Engine
21	106933X	Knob Rd 1/2-13 Plstc Thds	70	134683	Guide Belt Mower Drive RH
22	130804	Rod Brake Blk Zinc	72	19132012	Washer 13/32 x1-1/4 x 12 Ga
24	73350600	Nut Hex Jam 3/8-16 Unc	74	137057	Spacer Axle
25	106888X	Spring Rod Brake 2 00 Zinc	75	121749X	Washer 25/32 x1 1/4 x 16 Ga
26	19131316	Washer 13/32 x 13/16x16 Ga	76	12000001	E-ring #5133-75
27	76020412	Pin Cotter 1/8 x 3/4 Cad	77	123583X	Key Square 2 0 x 1845/ 1865
28	145204	Rod Brake Parking Lt/Yt	78	121748X	Washer 25/32 x 1-5/8 x 16ga
29	71673	Cap Brake Parking	79	2228M	Key Woodruff #9 3/16 x 3/4
30	130807	Bracket Mtg Transaxle	96	4497H	Retainer Spring
32	74760512	Bolt Fin Hex 5/16-18 x 3/4	112	19091210	Washer 9/32 x 3/4 x 10 Ga
34	155071	Shaft Asm Pedal Foot	113	127285X	Strap Torque
35	120183X	Bearing Nylon Blk 629 Id	116	72110610	Bolt Rdhd Sq Neck 3/8-16 x 1.25
36	19211616	Washer 21/32 x 1 x 16 Ga	145	74490540	Bolt Hex Flghd 5/16-18 Gr. 5
37	1572H	Pin Roll 3/16 x 1"	150	165850	Bushing Bellcrank Grd. Drive
38	131494	Pulley Idler Flat	151	19133210	Washer 13/32 x 2 x 10 Ga
39	74760644	Bolt Rdhd 3/8-16unc x 2-3/4 Gr. 5	170	165849	Keeper Belt Transaxle Gear
40	4470J	Spacer Split 395 x 59 Bzp	202	72110612	Bolt Carr Sh 3/8-16 x 1-1/2 Gr. 5
41	165838	Keeper Belt Idler	204	17060516	Screw 5/16-18 x 1
42	19131312	Washer 13/32 x 13/16x12 Ga			
47	127783	Pulley Idler V Groove Plastic			
48	154407	Bellcrank Clutch Grn Drv Stl			

NOTE: All component dimensions given in U.S. inches
1 inch = 25.4 mm

REPAIR PARTS

TRACTOR- -MODEL NO. 917.259040

STEERING ASSEMBLY

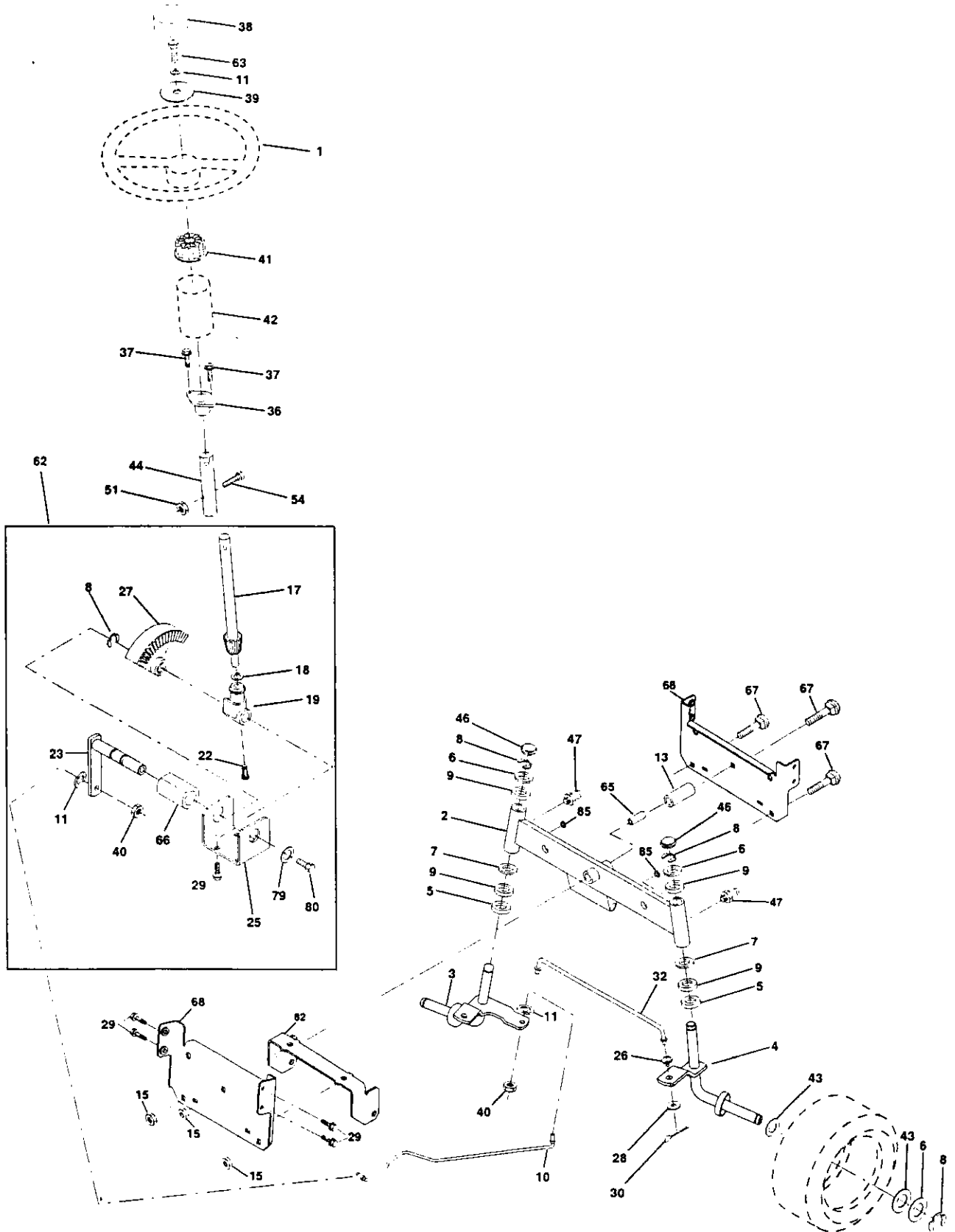

REPAIR PARTS

TRACTOR- -MODEL NO. 917.259040

STEERING ASSEMBLY

KEY NO.	PART NO.	DESCRIPTION
1	140044	Steering Wheel
2	154427	Front Axle Asm
3	156483	Spindle Asm Lh
4	157473	Spindle Asm Rh
5	6266H	Washer Thrust .75 x 1.230
6	121748X	Washer 25/32 x 1-5/8 x 16 Ga.
7	19272016	Washer 27/32 x 1-1/4 x 16 Ga.
8	12000029	RingKlip #T5304-75
9	3366R	Bearing Col Strg Blk
10	169832	Draglink
11	10040600	Washer Lock Hvy Hlcl Spr 3/8
13	136518	Spacer Brg Axle Front
15	145212	Nut Hexflange Lock
17	156546	Shaft Asm Strg
18	57079	Washer Thrust .515 x .750 x .033
19	160395	Support Shaft
22	165857	Screw Hex Wsh Hd Torx
23	165851	Shaft Asm Pitman
25	154406	Bracket Steering
26	126847X	Bushing Link Drag Blk LR
27	136874	Gear Sector 22 Teeth
28	19131416	Washer 13/32 x 7/8 x 16 Ga.
29	17060612	Screw 3/8-16 x 3/4
30	76020412	Pin
32	130465	Rod Tie Wire Form 19.75 Mech
36	155099	Bushing Strg. 5/8 ID Dash
37	152927	Screw
38	140045	Insert, Steering Wheel
39	19133812	Washer 13/32 x 2-3/8 x 12 Ga.
40	7810H	Nut Lock Center 3/8-24
41	100711L	Adaptor Wheel Strg.
42	145054X428	Boot Steering Dash P/L MTL Blk
43	121749X	Washer 25/32 x 1-1/4 x 16 Ga.
44	153720	Extension Steering Non-adjust
46	121232X	Cap Spindle Fr Top Blk
47	6855M	Fitting Grease
51	73800500	Nut Lock Hx W/Ins 5/16-18unc
54	74780520	Bolt Fin Hex 5/16-18unc
62	167902	Steering Assembly
63	74780616	Bolt Fin Hex 3/8-16unc x 1 Gr. 5
65	160367	Spacer Axle
66	154404	Bearing Arm Pittman
67	72140618	Bolt Rdhd Sqnk 3/8-16 x 2-1/4
68	169827	Brace Axle
79	19132012	Washer 13/32 x 1-1/4 x 12 Ga
80	74950612	Bolt Hex Nylon 3/8-16 x 3/4
82	169835	Bracket Susp Chasis Front
85	133835	Fastner Christmas Tree

NOTE: All component dimensions given in U.S. inches
1 inch = 25.4 mm

REPAIR PARTS

TRACTOR- -MODEL NO. 917.259040

SEAT ASSEMBLY

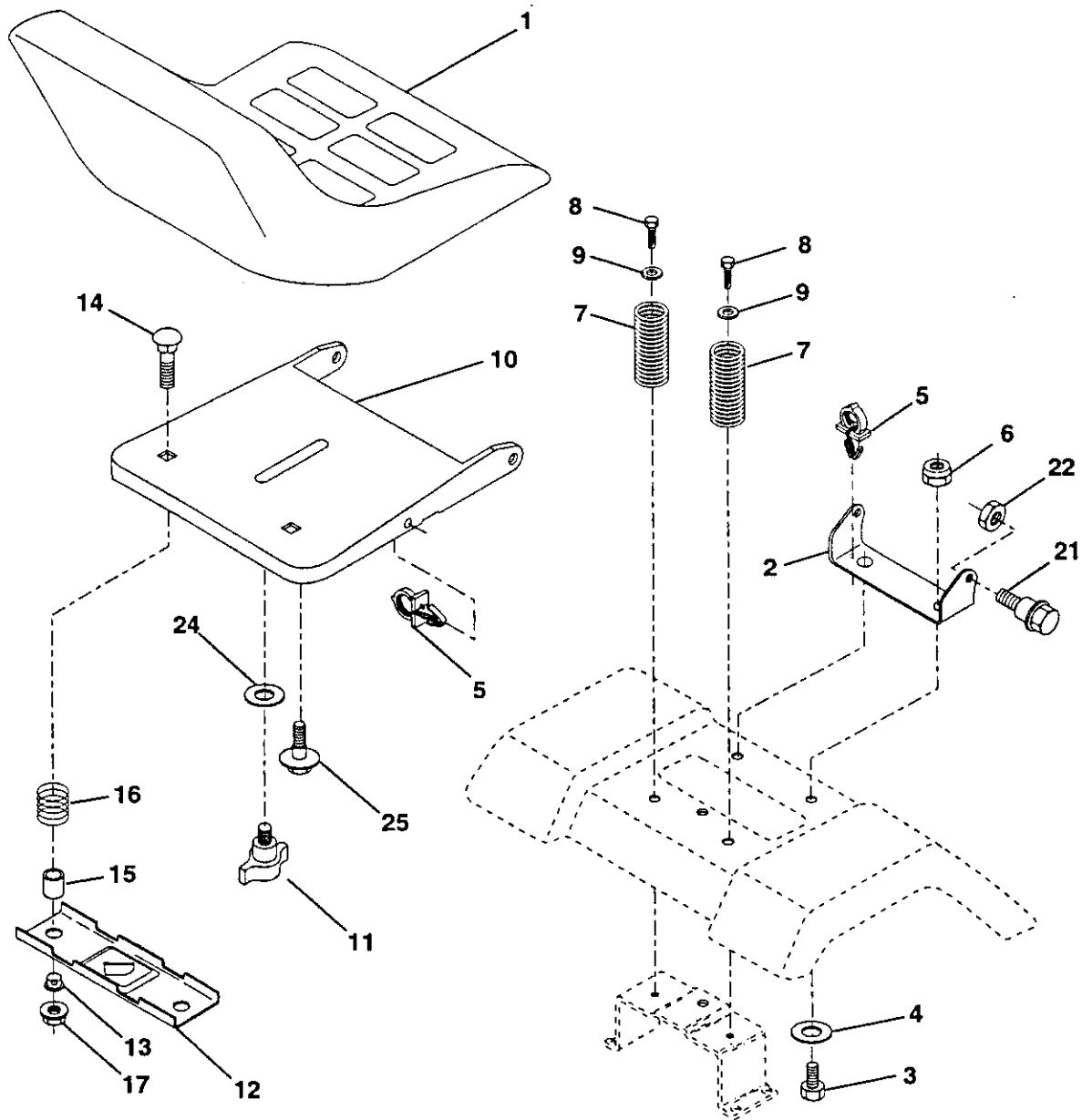

KEY NO.	PART NO.	DESCRIPTION
1	127427	Seat
2	140551	Bracket Pvt St
3	71110616	Bolt Fin Hex 3/8-16unc X 1
4	19131610	Washer Flat 13/32 X 1X10 Ga
5	145006	Clip Push-In Hinged
6	73800600	Nut Crownlock 3/8-16 UNC
7	124181X	Spring Seat Cprsn 2 250 Blk
8	17000616	Screw 3/8-16 X 1-1/2
9	19131614	Washer 13/32 X 1 X 14 Ga
10	155925	Pan Seat
11	166369	Knob Seat
12	121246X	Bracket Mounting Switch

KEY NO.	PART NO.	DESCRIPTION
13	121248X	Bushing Snap Blk Nyl 50 Id
14	72050412	Bolt Rdhd Sht 1/4-20x1-1/2
15	134300	Spacer Split 28x 96 Yel Zinc
16	121250X	Spring Cprsn 1 27 Blk Pnt
17	123976X	Nut Lock 1/4 Lge Flg Gr 5
21	171852	Bolt Shld 5/16-18 Unc-2A
22	73800500	Nut Crown Lock Hex 5/16-18
24	19171912	Washer 17/32 X1-3/16X12 Ga
25	127018	Bolt Shoulder

NOTE: All component dimensions given in U.S. inches
1 inch = 25.4 mm

REPAIR PARTS

TRACTOR- -MODEL NO. 917.259040

DECALS

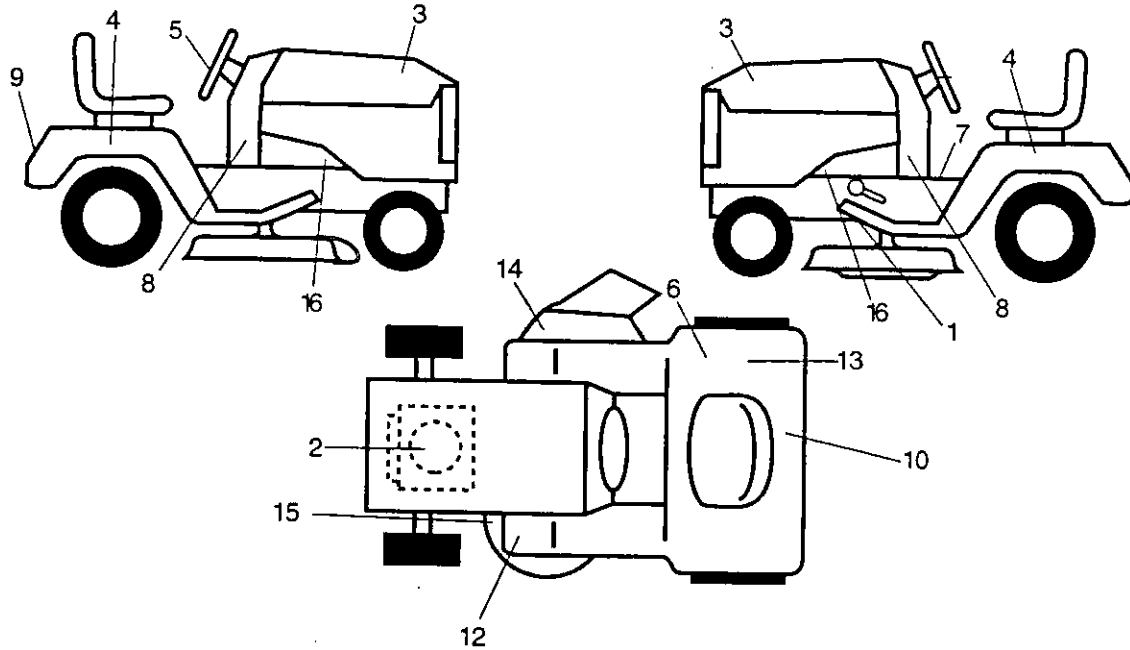

KEY NO.	PART NO.	DESCRIPTION
1	146046	Decal V-Belt Drive Sch
2	165387	Decal Engine HP
3	171704	Decal Hood
4	172276	Decal Fender
5	172275	Decal Ins Strg Whl
6	126187X	Decal Certification
7	140837	Decal Brake Parking
8	163248	Decal Panel Dash
9	163204	Decal Fender Logo
10	145005	Decal Battery Dngr/Psn

KEY NO.	PART NO.	DESCRIPTION
12	159737	Decal Clutch/Brake
13	145437	Decal Europ. Stand CE
14	145494	Decal International Cutfinger
15	136832	Decal Mower Drive Schem 38
16	159736	Decal Chassis Hot Muffler
--	138311	Decal Lift Handle
--	162598	Decal Drawbar Load Limit
--	173667	Manual Owners (Euro)
--	173668	Manual Owners (Scan)
--	173669	Manual Repair Parts

WHEELS & TIRES

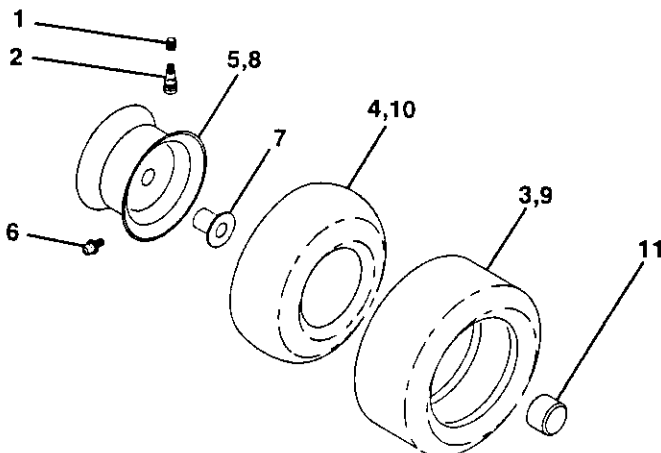

KEY NO.	PART NO.	DESCRIPTION
1	59192	Cap Value Tire
2	65139	Stem Value
3	106222X	Tire F Ts 15 X 6 0 - 6 Service
4	59904	Tube Inner Front #35060
5	106732X427	Rim Asm 6"front White Service
6	278H	Fitting Grease
7	9040H	Bearing Flange
8	106108X427	Rim Asm 8"rear White Service
9	124635X	Tire R Ts 18x8 5-8 Service
10	7152J	Tube Rear 9 5 X 8 Service
11	104757X	Cap Axle Blk 1 50 X 1 00
--	144334	Sealant, Tire (10 oz. tube)

NOTE: All component dimensions given in U.S. inches
1 inch = 25.4 mm

REPAIR PARTS

TRACTOR- -MODEL NO. 917.259040

ENGINE

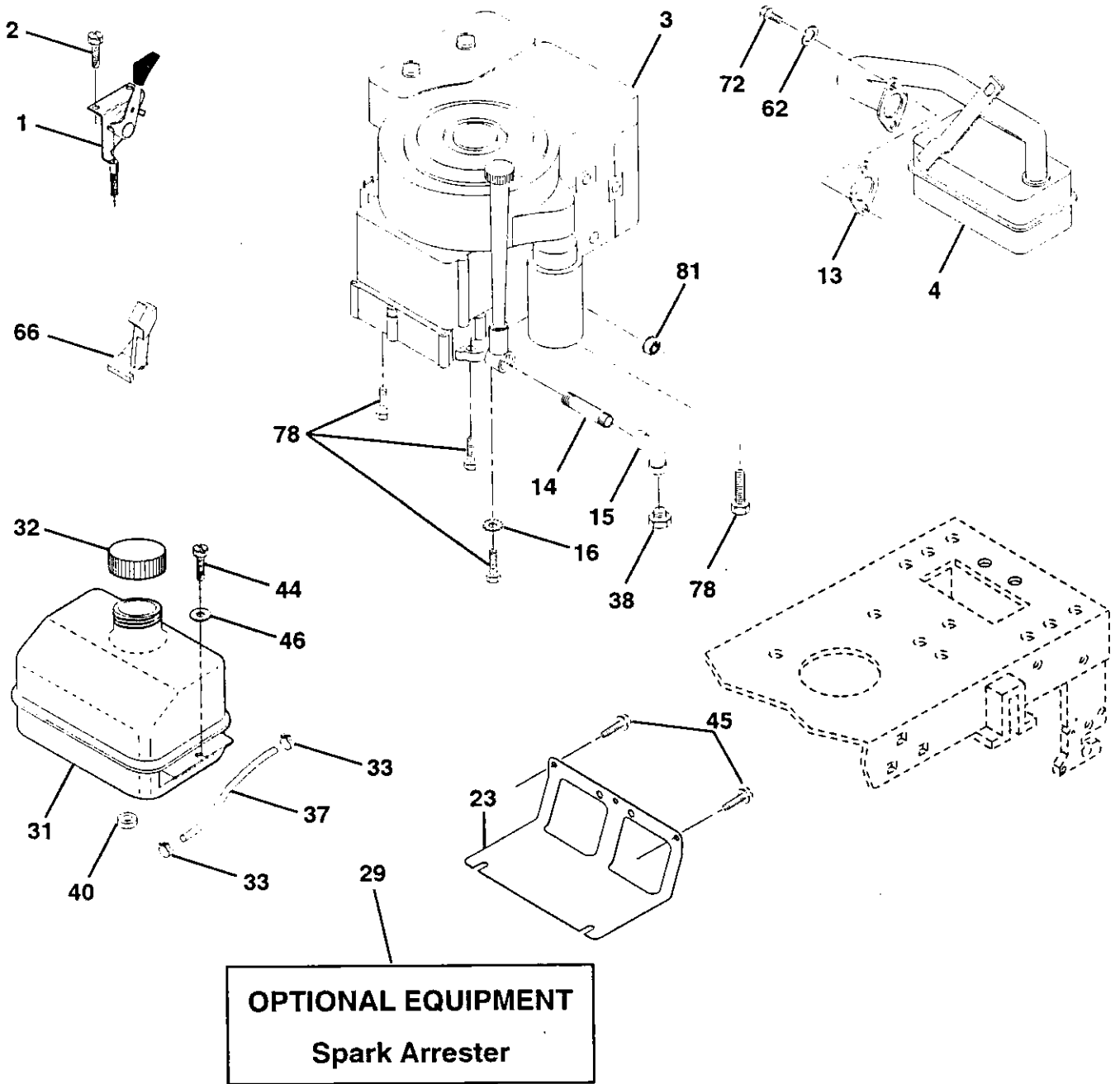

REPAIR PARTS

TRACTOR- -MODEL NO. 917.259040

ENGINE

KEY NO.	PART NO.	DESCRIPTION
1	141359	Control Th/ch LH IV 1 80 20 22
2	17720410	Screw Hex Thd Cut 1/4-20x5/8 T
3	-----	Engine (See Breakdown)
4	137348	Briggs, Model No 28R707-1140-E3 Muffler Exh LT B&S
13	165291	Gasket Eng 1 313 Id Tin Plated
14	13280324	Nipple Pipe 3/8 Npt x 3"
15	13200300	Elbow Std 90 Degree 3/8-18 Npt
16	11050600	Washer Lock Ext Tooth 3/8
23	169837	Shield Browning/Debris Guard
29	137180	Kit Spark Arrestor (Flat Scrn)
31	109202X	Tank Fuel Front 1 25
32	158990	Cap Asm Fuel Sears Vented
33	123487X	Clamp Hose Blk
37	137040	Line Fuel 20"
38	-----	Plug Oil Drain (See Engine Breakdown)
40	124028X	Bushing Snap Nyl Blk Fuel Line
44	17670412	Screw Hexwsh Thdrol 1/4-20 x 3/4
45	17000612	Screw 3/8-16 x 3/4
46	19091416	Washer 9/32 x 7/8 x 16 ga
62	10040500	Washer Lock Hvy Hlcl Spr 5/16
66	127951	Stop, Throttle
72	71070512	Screw Hex Hd Cap 5/16-18 X 3/4
78	17060620	Screw 3/8-16 x 1-1/4
81	73510400	Nut Flange 1/4-20 Starter Nut

NOTE: All component dimensions given in U.S. inches
1 inch = 25.4 mm

REPAIR PARTS

TRACTOR- -MODEL NO. 917.259040

MOWER LIFT

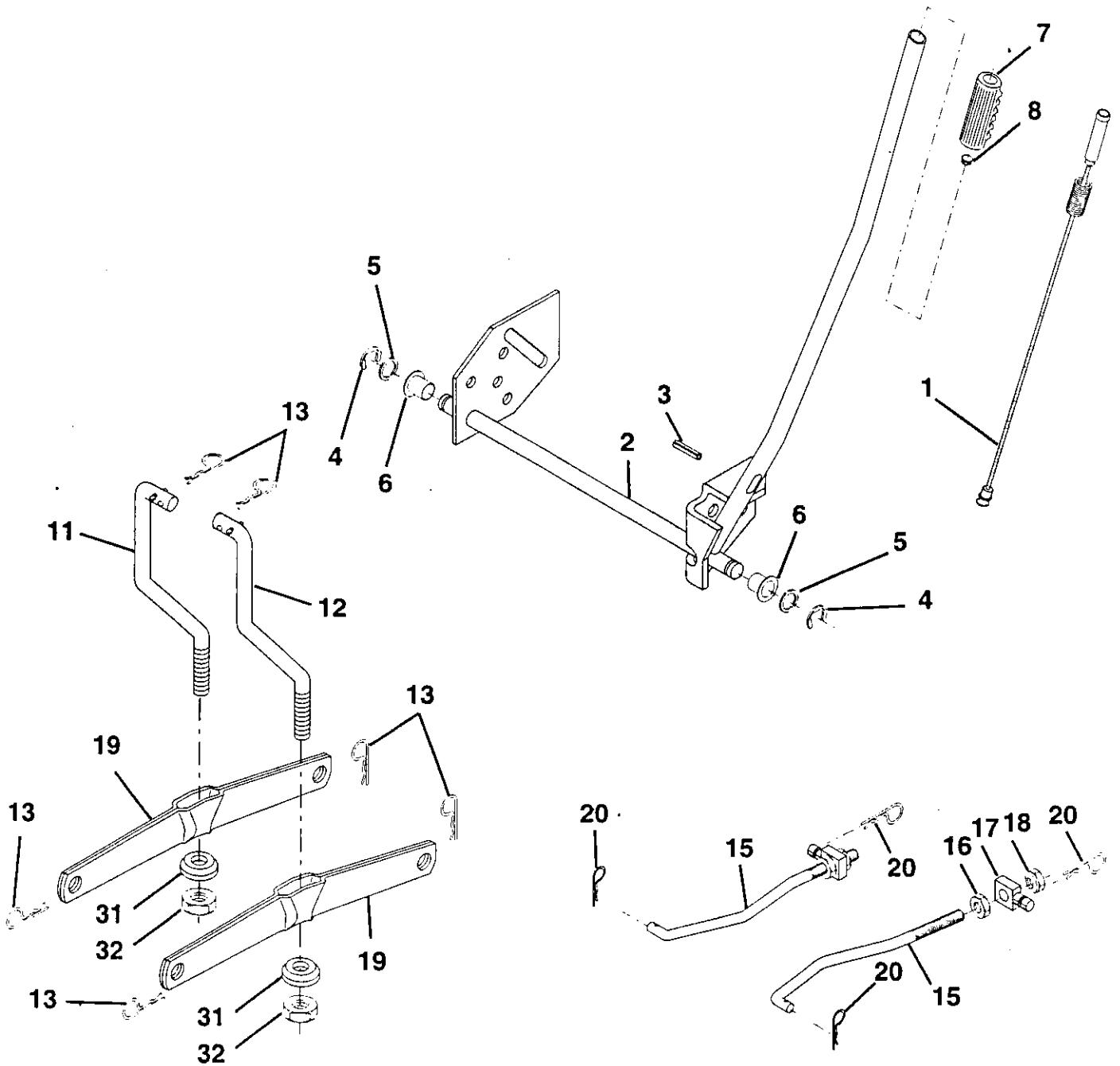

REPAIR PARTS

TRACTOR- -MODEL NO. 917.259040

MOWER LIFT

KEY NO.	PART NO.	DESCRIPTION
1	159460	Lift Lever Inner Wire Assembly
2	159471	Shaft Assembly, Lift
3	105767X	Pin, Groove
4	12000002	E-Ring
5	19211621	Washer 21/32 x 1 x 21 Gauge
6	120183X	Bearing, Nylon
7	125631X	Grip, Handle, Fluted
8	122365X	Button, Plunger, Red
11	139865	Link, Lift, L.H.
12	139866	Link, Lift, R.H.
13	4939M	Retainer Spring
15	173288	Link, Front
16	73350800	Nut, Hex, Jam 1/2-13 UNC
17	130171	Trunnion
18	73800800	Locknut, Hex, with Washer Insert 1/2-13 UNC
19	139868	Arm, Suspension, Rear
20	163552	Retainer Spring
31	140302	Bearing, Pvt, Lift Spherical
32	73540600	Nut, Crownlock 3/8-24

NOTE: All component dimensions given in U.S. inches
1 inch = 25.4 mm

REPAIR PARTS

TRACTOR- -MODEL NO. 917.259040

MOWER

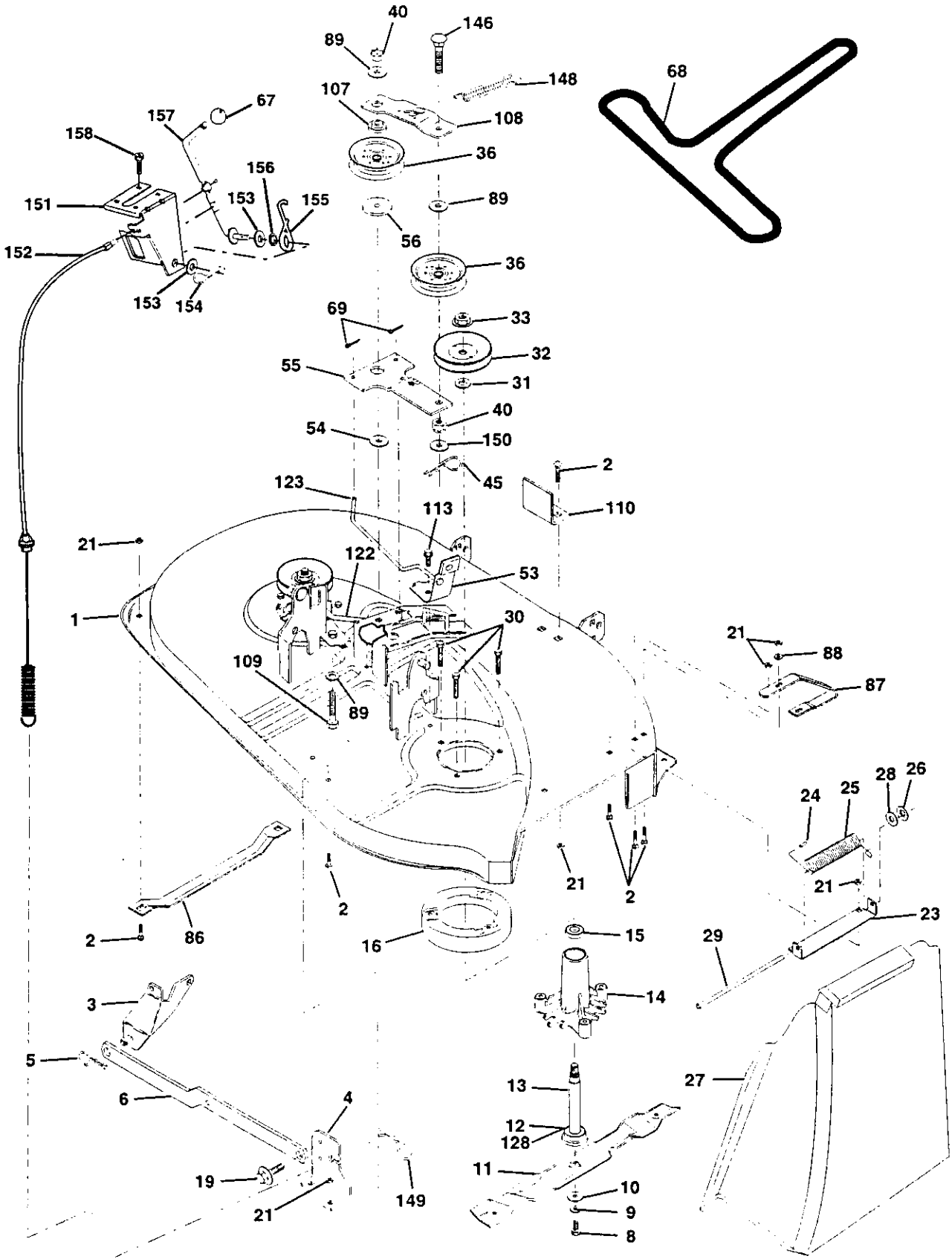

REPAIR PARTS

TRACTOR- -MODEL NO. 917.259040

MOWER

KEY NO.	PART NO.	DESCRIPTION	KEY NO.	PART NO.	DESCRIPTION
1	170280	Mower Deck Assembly	67	149846	Knob RD 3/8-16 Plstc Thd
2	72140506	Bolt	68	144200	Belt
3	138017	Bracket Assembly, Sway Bar	69	76020312	Pin, Cotter 3/32 x 3/4
4	169970	Bracket Sway Bar Deck	86	7631J	Runner, LH
5	4939M	Retainer Spring	87	128772	Runner, RH
6	130832	Arm, Suspension, Rear	88	19111216	Washer 11/32 x 3/4 x 16 Ga
8	850857	Bolt, Hex 3/8-24 x 1.25 Gr. 8	89	19131612	Washer 13/32 x 1 x 12 Ga
9	10030600	Washer, Lock Hvy Hlcl 3/8	107	133502	Spacer, Retainer
10	140296	Washer, Hardened	108	133503	Stiffener, Idler Arm
11	134148	Blade, Mower 38	109	74760640	Bolt, Hex Head 3/8-16 x 2-1/2
12	129895	Bearing, Ball	110	142587	Upstop Deck Front 38
13	137645	Shaft Assembly, Mandrel, Vented (Includes Key #12)	113	17060512	Screw 5/16-18 x 3/8
14	128774	Housing, Mandrel, Vented	122	131289	Rod, Brake, LH
15	110485X	Bearing, Ball, Mandrel	123	169971	Rod, Brake, RH
16	140329	Stripper, Vented Mower Deck	128	153390	Washer Felt
19	132827	Bolt, Shoulder	146	165891	Bolt Carriage Idler
21	73680500	Nut Crownlock 5/16-18	148	169022	Spring Return Idler
23	137607	Bracket, Mower Deflector	149	165898	Retainer Spring Yellow Zinc
24	105304X	Cap, Sleeve	150	19091216	Washer 9/32 x 3/4 x 16 Ga.
25	123713X	Spring, Torsion, Deflector	151	169670	Bracket Clutch
26	110452X	Nut, Push	152	172758	Cable Clutch 38 In
27	106736X428	Shield, Deflector	153	169674	Washer Flat 3/8" Type B
28	19111016	Washer 11/32 x 5/8 x 16 Ga.	154	169675	Spring Retainer
29	106735X	Rod, Hinge	155	169671	Spring Retention Lever
30	157722	Screw Thdrol Washer Head	156	169672	Spacer
31	129963	Washer, Spacer	157	169669	Rod Clutch
32	153532	Pulley, Mandrel	158	17720410	Screw Hex Thd Cut 1/4-20x5/8
33	137266	Nut, Toplock, Flanged	--	130794	Mandrel Assembly (Includes Key Numbers 12-15, 17-19, 31 and 33)
36	131494	Pulley, Idler, Flat	--	171665	Mower Deck, Complete
40	73680600	Nut Crownlock 3/8-16			
45	4497H	Retainer, Spring			
53	130840	Brake Assembly			
54	133943	Washer, Hardened			
55	133840	Idler Arm Assembly			
56	165723	Spacer, Retainer			

NOTE: All component dimensions given in U.S. inches
1 inch = 25.4 mm

REPAIR PARTS

TRACTOR - - MODEL NUMBER 917.259040

PEERLESS TRANSAXLE MODEL NUMBER -- 205-544C

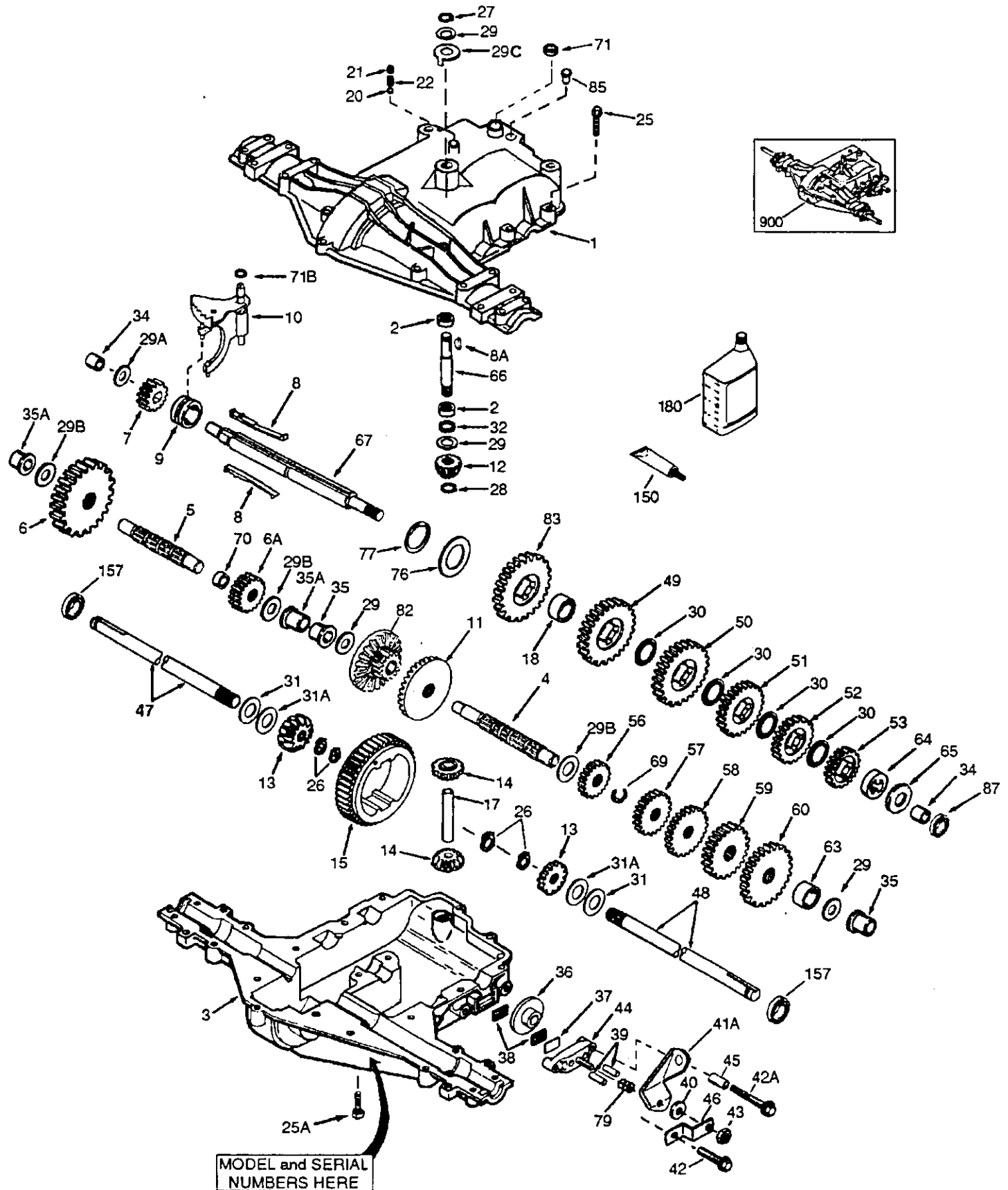

REPAIR PARTS

TRACTOR - - MODEL NUMBER 917.259040

PEERLESS TRANSAXLE MODEL NUMBER -- 205-544C

KEY NO.	PART NO.	DESCRIPTION	KEY NO.	PART NO.	DESCRIPTION
1	772147	Transaxle Cover	39	.786026	Dowel Pin
2	780086A	Needle Bearing 5 / 8"	40	792076A	Flat Washer .312 ID x .059W
3	770128	Transaxle Case	41A	790079	Brake Lever
4	776395	Countershaft	42	792073A	Screw 1 / 4 - 20 x 1 - 1 / 4"
5	776409	Output Shaft	42A	792085A	Screw 1 / 4 - 20 x 2 - 1 / 4"
6	778364	Spur Gear (38 teeth)	43	792075	Locknut 5 / 16 - 24
6A	778369	Spur Gear (15 teeth)	44	790025	Brake Pad Holder
7	778330	Spur Gear (11 teeth)	45	786066	Spacer .2625 x 1.0
8	792180	Shift Key	46	786086	Brake Lever Bracket
8A	792047	Woodruff Key #9	47	774690	Axle (11 - 15 / 16 " long)
9	784352	Shift Collar	48	774691	Axle (16 - 1 / 2" long)
10	784378	Shift Rod & Fork	49	778356	Spur Gear (29 teeth)
11	778334	Bevel Gear (30 teeth)	50	778354	Spur Gear (23 teeth)
12	778309	Input Bevel Pinion (13 teeth)	51	778352	Spur Gear (19 teeth)
13	778368	Bevel Gear (13 teeth) (Include. 14)	52	778350	Spur Gear (16 teeth)
14	778368	Bevel Pinion (13 teeth) (Include 13)	53	778346	Spur Gear (15 teeth)
15	778370	Ring Gear (43 teeth)	53	778346	Spur Gear (15 teeth - steel)
17	786188	Drive Pin	56	778355	Spur Gear (11 teeth)
18	786102	Spacer 1.130 x .695	57	778353	Spur Gear (17 teeth)
20	792077A	Ball 5 / 6" dia	58	778351	Spur Gear (21 teeth)
21	792078	Set Screw 3 / 8-16 x 3 / 8"	59	778349	Spur Gear (24 teeth)
22	792079	Spring .310 OD x .625 L	60	778345	Spur Gear (25 teeth)
25	792073A	Screw 1/4 - 20 x 1-1 / 4"	63	786071	Countershaft Spacer 1 - 1 / 8" x 3 / 8"
25A	792177	Screw 1 / 4 - 20 x 1 - 3 / 8"	64	786072	Brake Shaft Spacer 1 - 3 / 8" x 3 / 8"
26	792125	Retaining Ring (pkg of 2)	65	780189	Flat Washer .563 ID x .062W
27	792035	Retaining Ring	66	776422	Input shaft
28	788040	Retaining Ring	67	776396	Shifter & Brake shaft
29	780072	Thrust Washer .627 ID x .031W	69	792170	Retaining Ring
29A	780160	Thrust Washer .563 ID x .031W	70	786187	Spacer .890
29B	780051	Thrust Washer .762 ID x .031W	71	788069	Square Cut Ring
29C	780199	Anti -Rotation Washer .632	71B	788092	"O" Ring
30	780108	Cup Washer 1.127 ID x .032W	76	780090	Flat Washer 1.128 ID x .058W
31	780001	Flat Washer .750 ID x .056 (Use as Needed)	77	788078A	Inverted Retaining Ring
31A	780195	Flat Washer .750 ID x .062W	79	792144	Spring .430 OD x .5000 L
32	788083	Oil Seal 5 / 8"	82	778333	Bevel & Spur Gear (30 & 13 teeth)
34	780194	Bushing .563	83	778338	Spur Gear (27 teeth)
35	780193	Flanged Bushing 5 / 8" ID	85	792154	Oill Fill Plug
35A	780197	Flanged Bushing .751	87	788089A	Oil Seal 9 / 16"
36	790075	Brake Disk	150	788093A	Liquid Gasket RTV Silicone
37	790007	Brake Pad Plate	157	788088A	Oil Seal 3 / 4"
38	799021	Brake Pad (pkg of 2)	180	730229A	Gear Oil 80W90
			900	794711	Replacement MST-205-544C Transaxle

NOTE: All component dimensions given in U.S. inches
1 inch = 25.4 mm

REPAIR PARTS

TRACTOR - - MODEL NUMBER 917.259040

BRIGGS - MODEL NUMBER 28R707, TYPE NUMBER 1140-E3

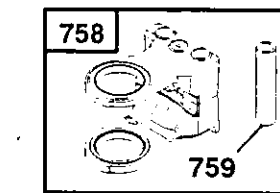
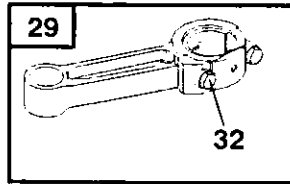
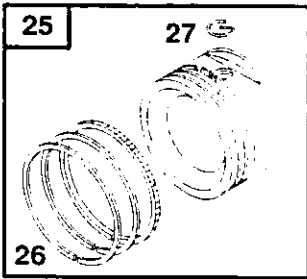
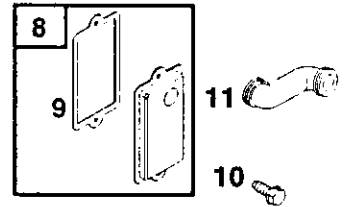
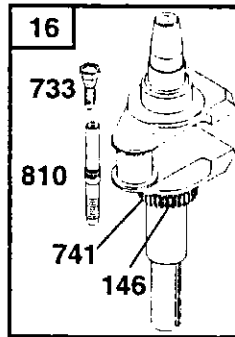
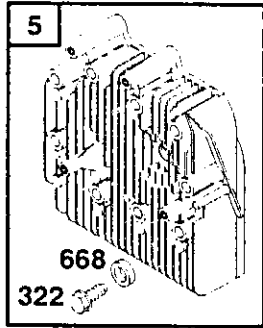
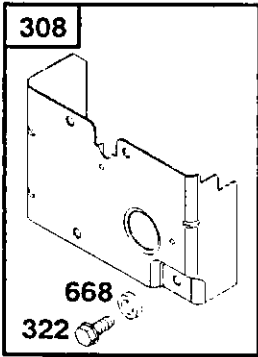
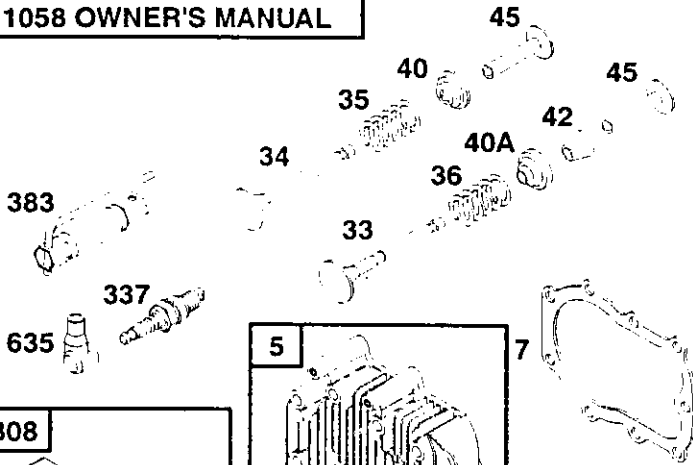
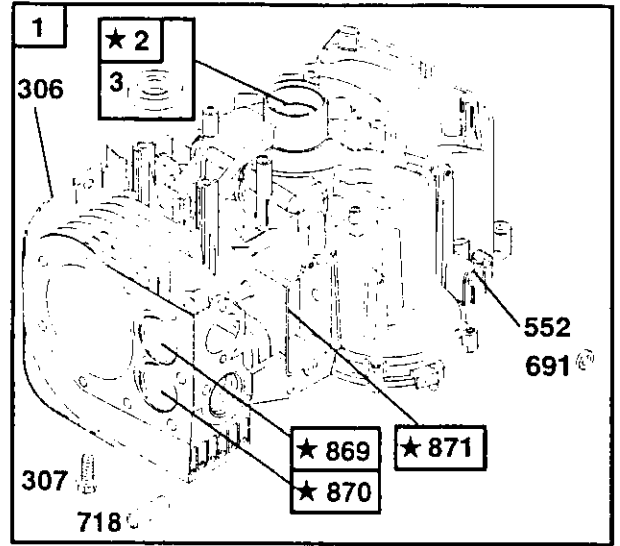
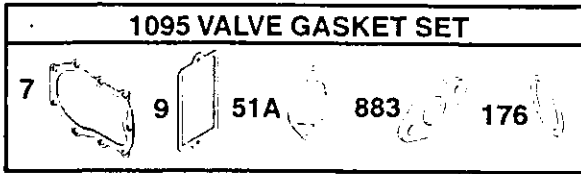

★ REQUIRES SPECIAL TOOLS TO INSTALL. SEE REPAIR INSTRUCTION MANUAL.

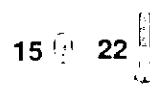
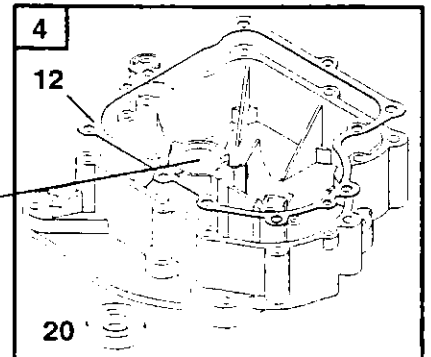
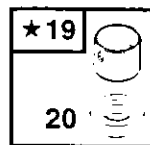
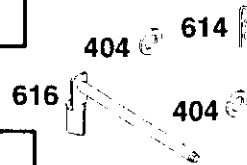
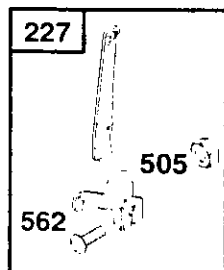
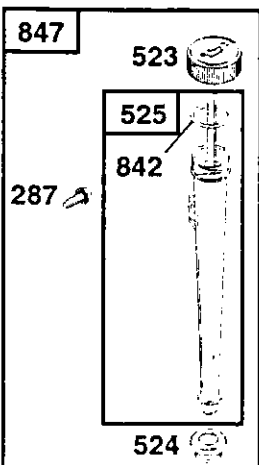
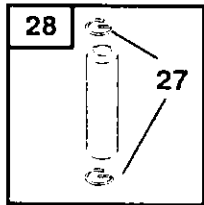
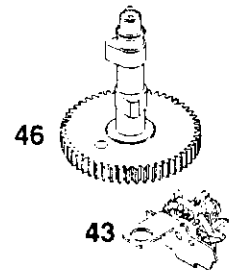

REPAIR PARTS

TRACTOR - - MODEL NUMBER 917.259040

BRIGGS - MODEL NUMBER 28R707, TYPE NUMBER 1140-E3

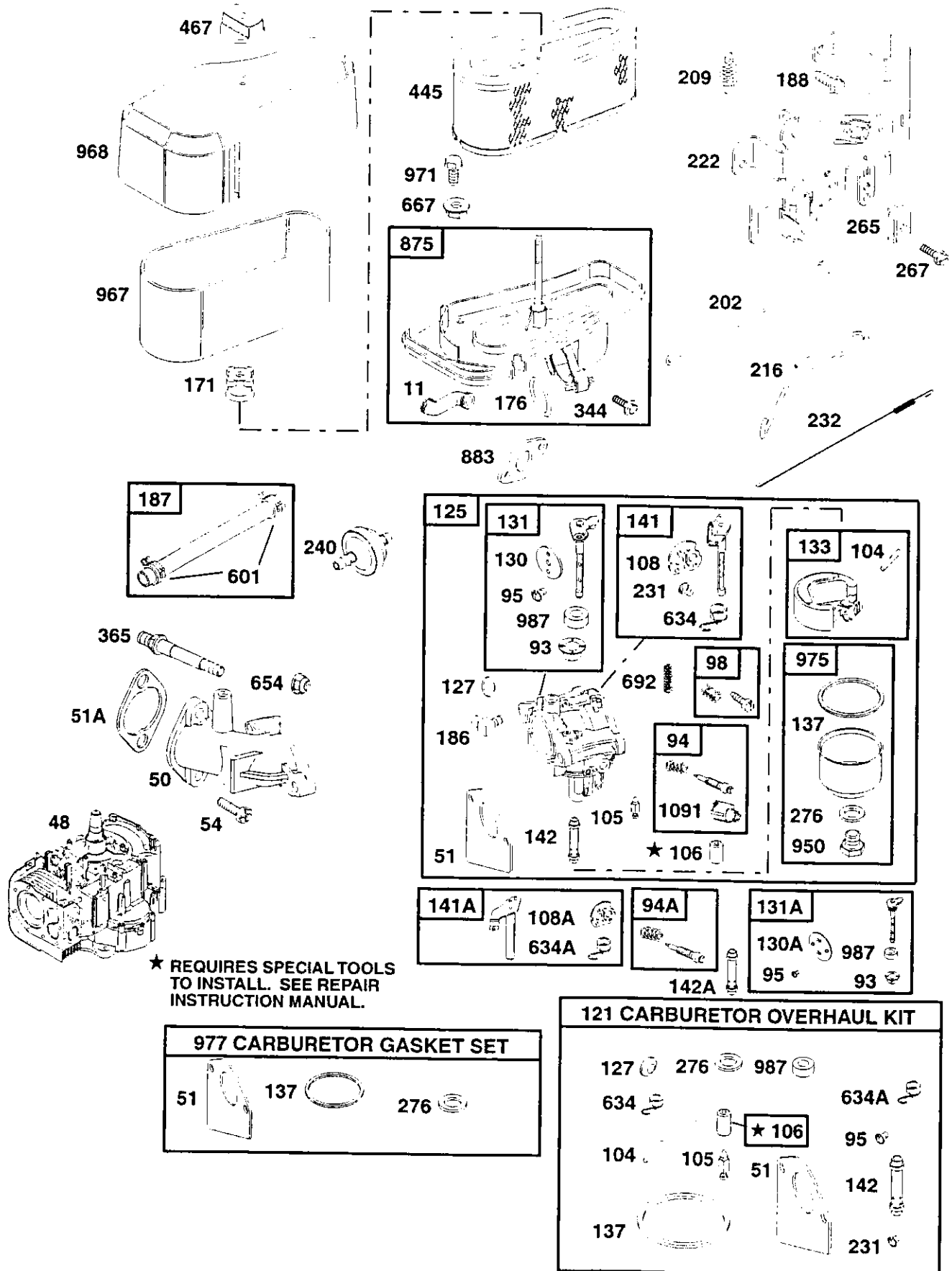

★ REQUIRES SPECIAL TOOLS TO INSTALL. SEE REPAIR INSTRUCTION MANUAL.

REPAIR PARTS

TRACTOR - - MODEL NUMBER 917.259040

BRIGGS - MODEL NUMBER 28R707, TYPE NUMBER 1140-E3

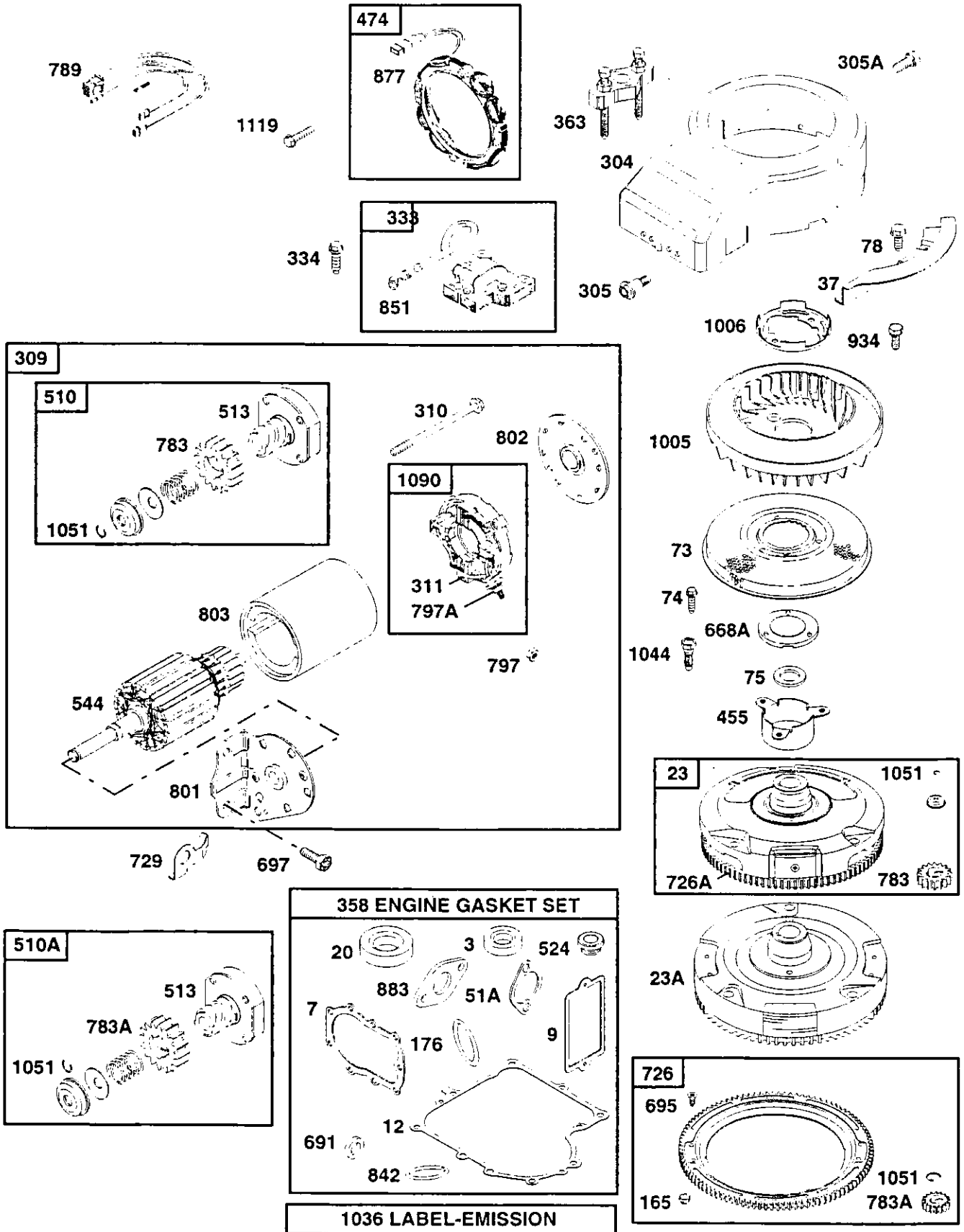

REPAIR PARTS

TRACTOR - - MODEL NUMBER 917.259040

BRIGGS - MODEL NUMBER 28R707, TYPE NUMBER 1140-E3

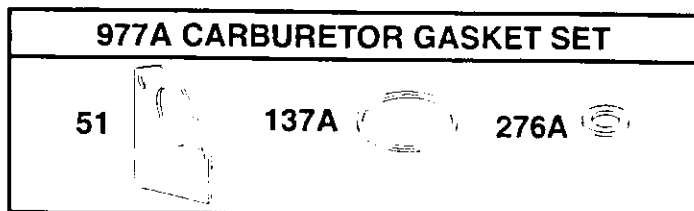
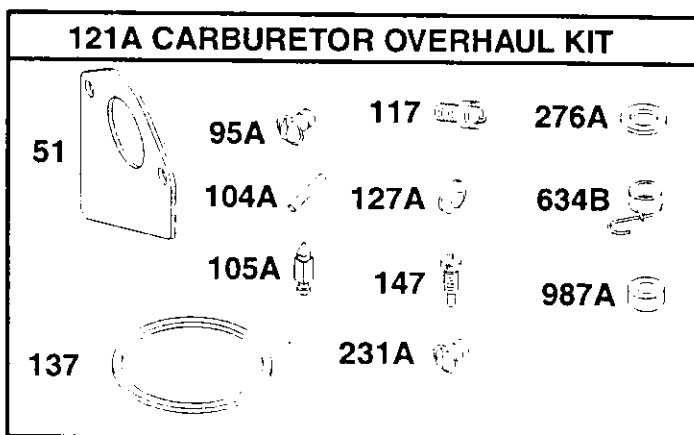
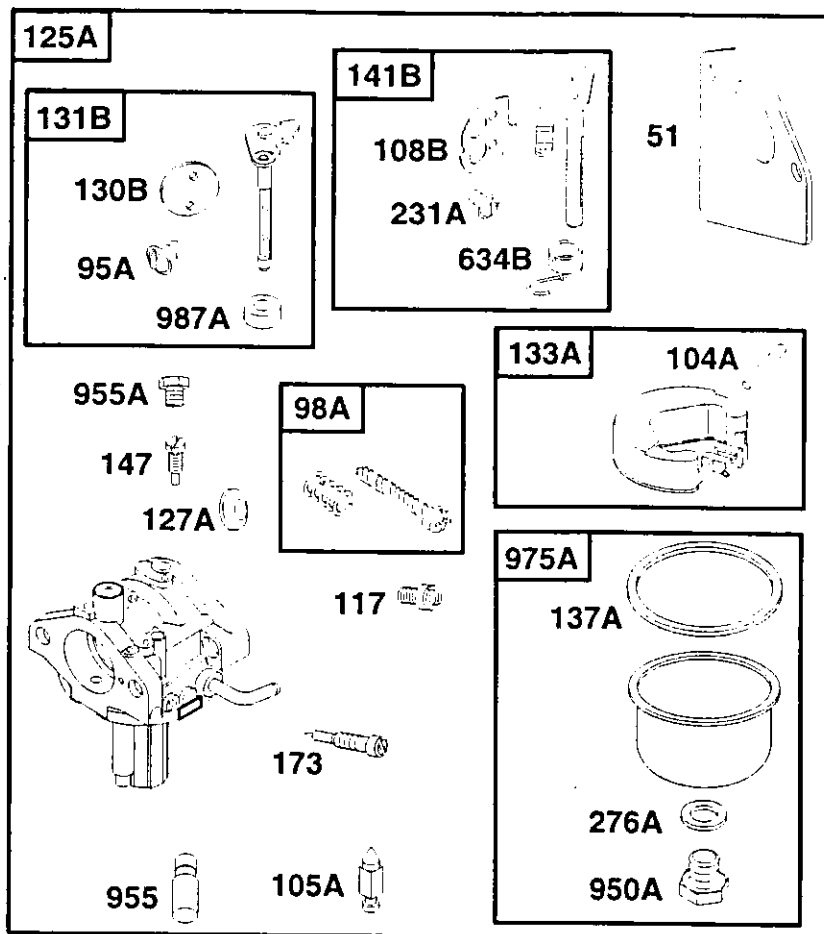

REPAIR PARTS

TRACTOR - - MODEL NUMBER 917.259040

BRIGGS - MODEL NUMBER 28R707, TYPE NUMBER 1140-E3

KEY NO.	PART NO.	DESCRIPTION	KEY NO.	PART NO.	DESCRIPTION
1	496413	Cylinder Assembly	105	231855	● Float Needle Valve
2	399265	Bushing/Seal Kit (Magneto Side)	105A	694922	● Float Needle Valve
3	391086	★ Oil Seal	106	231854	● Inlet Seat
4	494238	Engine Sump	108	690464	Choke Valve (Manual Choke)
5	494240	Cylinder Head	108A	692344	Choke Valve (Choke A Matic)
7	271866	★+ Cylinder Head Gasket	108B	694923	Choke Valve
8	495735	Breather Assembly	117	690880	● Main Jet
9	27803	★+ Breather Gasket		694925	● Main Jet (High Altitude)
10	691666	Screw (Breather Assembly)	121	499220	Carburetor Overhaul Kit
11	280100	Breather Tube		499231	Carburetor Overhaul Kit (LMT 157)
12	271916	★ Crankcase Gasket (.015 Thick, Std.)	121A	694930	Carburetor Overhaul Kit
	271997	★ Crankcase Gasket (.005 Thick)	125	498027	Carburetor (Walbro Carburetor)
	271996	★ Crankcase Gasket (.009 Thick)	125A	694941	Carburetor (Nikki Carburetor)
13	94622	Screw (Cylinder Head)	127	695005	● Welch Plug
15	94239	Oil Drain Plug	127A	694916	● Welch Plug
16	495162	Crankshaft	130	690468	Throttle Valve
19	490666	Bushing/Seal Kit (PTO Side)	130A	224539	Throttle Valve (Use on LMT 92)
20	291675	★ Oil Seal	130B	694917	Throttle Valve
22	692125	Screw (Engine Sump)	131	494485	Throttle Shaft Kit
23	693556	Flywheel (Steel Ring Gear)	131A	494379	Throttle Shaft Kit
23A	692682	Flywheel (Plastic Ring Gear)	131B	694909	Throttle Shaft Kit
24	222698	Flywheel Key	133	494381	Carburetor Float
25	499282	Piston Assembly (Standard)	133A	694914	Carburetor Float
	394662	Piston Assembly (.010 O.S.)	137	281165	●◆ Float Bowl Gasket
	394663	Piston Assembly (.020 O.S.)	137A	694920	●◆ Float Bowl Gasket
	394664	Piston Assembly (.030 O.S.)	141	495097	Choke Shaft Kit (Manual Choke)
26	391780	Ring Set (Standard)	141A	495931	Choke Shaft Kit (Choke A Matic)
	392331	Ring Set (Chrome, Standard)	141B	694913	Choke Shaft Kit
	391781	Ring Set (.010 O.S.)	142	691434	● Carburetor Nozzle (Standard, LMT 92, 93, 94, 96)
	391782	Ring Set (.020 O.S.)		497737	Carburetor Nozzle (High Altitude, LMT 92, 96)
	499999	Ring Set (.030 O.S.)	142A	691425	● Carburetor Nozzle (Standard, LMT 81, 157)
27	691299	Piston Pin Lock		497567	Carburetor Nozzle (High Altitude, LMT 157)
28	498319	Piston Pin	146	94196	Timing Key
29	494504	Connecting Rod (Standard)	147	694927	● Pilot Jet
	490469	Connecting Rod (.020 Undersize)	165	693148	Nut (Ring Gear)
32	691133	Screw (Connecting Rod)	171	281051	Nut (Air Cleaner)
33	262246	Exhaust Valve	173	694926	Idle Mixture Valve
34	262247	Intake Valve	176	281106	★+ O-Ring Seal (Air Cleaner Base)
35	65906	Valve Spring (Intake)	186	493496	Hose Connector
36	26828	Valve Spring (Exhaust)	187	298049	Fuel Line (Cut to Required Length)
37	690456	Flywheel Guard	188	94929	Screw (Control Bracket)
40	221596	Valve Retainer	202	262767	Mechanical Governor Link
40A	292260	Valve Retainer	209	260871	Governor Spring
42	494553	Valve Keeper	216	262766	Choke Link
43	490815	Governor/Oil Slinger	222	694042	Control Bracket
45	262248	Valve Tappet	227	691374	Governor Control Lever
46	692123	Camshaft	231	94098	● Screw (Choke Valve)
48	496606	Short Block	231A	805538	● Screw (Choke Valve)
50	213819	Intake Manifold	232	262785	Governor Link Spring
51	272465	●◆ Intake Gasket	240	394358	Fuel Filter
51A	272554	★+ Intake Gasket			
54	94913	Screw (Intake Manifold)			
73	690492	Rotating Screen			
74	94626	Screw (Rotating Screen)			
75	225136	Washer (Flywheel)			
78	94896	Screw (Flywheel Guard)			
93	690602	Throttle Shaft Bushing			
94	498030	Idle Mixture Kit			
94A	494383	Idle Mixture Kit			
95	94098	● Screw (Throttle Valve)			
95A	805538	● Screw (Throttle Valve)			
98	495800	Idle Speed Kit			
98A	694907	Idle Speed Kit			
104	690525	● Float Hinge Pin			
104A	694918	● Float Hinge Pin			

RPM Settings: Low Speed: 1900-2100
High Speed: 3000-3200

- ★ Included in Engine Gasket Set, Ref Number 358.
- Included in Carburetor Overhaul Kit, Ref Number 121.
- ◆ Included in Carburetor Gasket Set, Ref Number 977.
- + Included in Valve Gasket Set, Ref Number 1095.

NOTE: All component dimensions given in U.S. inches
1 inch = 25.4 mm

REPAIR PARTS

TRACTOR - - MODEL NUMBER 917.259040

BRIGGS - MODEL NUMBER 28R707, TYPE NUMBER 1140-E3

KEY NO.	PART NO.	DESCRIPTION	KEY NO.	PART NO.	DESCRIPTION
265	221535	Casing Clamp	758	399891	Counterweight
267	695134	Screw (Casing Clamp)	759	691239	Counterweight Pin
276	281164	◆ Sealing Washer	761	691096	Screw (Counterweight)
276A	690997	◆ Sealing Washer	783	693713	Pinion Gear (For Steel Ring Gear Only)
287	94903	Screw (Oil Fill Tube)	783A	693058	Pinion Gear (For Plastic Ring Gear Only)
304	691399	Blower Housing	789	695050	Wiring Harness
305	692127	Screw (Blower Housing)	797	92278	Nut (Starter Terminal)
305A	94786	Screw (Blower Housing)	797A	693167	Nut (Starter Terminal)
306	690459	Cylinder Shield	801	691429	Drive Cap
307	94930	Screw (Cylinder Shield)	802	497607	End Cap
308	491490	Cylinder Head Cover	803	693757	Starter Housing
309	693551	Starter Motor (For Steel Ring Gear Only)	810	231828	Crankshaft Extension
	497595	Starter Motor (For Plastic Ring Gear Only)	842	270920	★ Dipstick/Tube Seal
310	690323	Screw (Starter Motor)	847	496415	Dipstick/Tube Assembly
311	497608	Brush Set	851	493880	Sparkplug Terminal
322	94786	Screw (Cylinder Cover)	869	261463	Valve Seat (Intake)
333	492341	Magneto Armature	870	262924	Valve Seat (Exhaust)
334	94731	Screw (Magneto Armature)	871	261961	Guide Bushing (Exhaust)
337	802592	Sparkplug		231218	Guide Bushing (Intake)
344	693675	Screw (Cable Clamp)	875	694942	Air Cleaner Base (Used With Nikki Carburetor)
358	494241	Engine Gasket Set		693676	Air Cleaner Base (Used With Walbro Carburetor)
363	19203	Flywheel Puller	877	393456	Alternator Connector/Wire
365	94637	Stud (Carburetor)	883	272293	★ Exhaust Gasket
383	89838	Sparkplug Wrench	934	94627	Screw (Fan Retainer)
404	94927	Washer (Governor Crank)	950	94642	Float Bowl Screw
445	496894	A/C Cartridge Filter	950A	694919	Float Bowl Screw
455	691173	Flywheel Cup	955	694924	● Carburetor Plug
467	493903	Air Cleaner Knob	955A	694921	Carburetor Plug
474	393474	Alternator (Regulated)	967	272403	Pre Cleaner Filter
505	231082	Nut (Governor Control Lever)	968	281104	Air Cleaner Cover
510	693699	Starter Drive	971	692126	Screw (Air Cleaner Base)
513	398003	Drive Clutch	975	495933	Float Bowl
523	495230	Dipstick	975A	694908	Float Bowl
524	281370	★ Dipstick Tube Seal	977	494385	Carburetor Gasket Set
525	496113	Dipstick Tube	977A	694931	Carburetor Gasket Set
544	497603	Starter Armature	987	691326	● Throttle Shaft Seal
552	491986	Governor Lever Bushing	987A	281765	Throttle Shaft Seal
562	92613	Bolt (Governor Control Lever)	1005	695056	Flywheel Fan
601	95162	Hose Clamp	1006	690452	Fan Retainer
614	93306	Cotter Pin	1036	695036	Emissions Label
616	495157	Governor Crank	1044	94673	Screw (Flywheel)
634	690801	● Spring/Seal Assembly (Manual Choke)	1051	263080	Retaining Ring
634A	690802	● Spring/Seal Assembly (Choke A Matic)	1058	273681	Owner's Manual
634B	694912	● Spring/Seal Assembly	1090	497605	Brush Retainer
635	66538	Sparkplug Boot	1091	691333	Limiter Cap
654	94010	Nut (Carburetor)	1095	498539	Valve Gasket Set
667	94010	Nut (Air Cleaner Base)	1119	93621	Screw (Alternator)
668	690510	Spacer	— —	28R707-0028-E1	Replacement Engine
668A	691323	Spacer			
691	491323	★ Governor Shaft Seal			
692	690572	Detent Spring			
695	693109	Screw (Ring Gear)			
697	690372	Screw (Drive Cap)			
718	230192	Locating Pin			
726	399676	Ring Gear (Aluminum-Services Plastic Ring Gear Only)			
726A		Ring Gear (See Ref. 23 for Servicing)			
729	691224	Wire Clip			
733	94673	Screw (Crankshaft Extension)			
741	691284	Timing Gear			
757	213998	Counterweight Link			

RPM Settings: Low Speed: 1900-2100
High Speed: 3000-3200

- ★ Included in Engine Gasket Set, Ref Number 358.
- Included in Carburetor Overhaul Kit, Ref Number 121.
- ◆ Included in Carburetor Gasket Set, Ref Number 977.
- + Included in Valve Gasket Set, Ref Number 1095.

NOTE: All component dimensions given in U.S. inches
1 inch = 25.4 mm

SERVICE NOTES
