

REPAIR PARTS MANUAL
MODEL NO. 259090
Lawn Tractor

20 hp Kohler

4/6"

CRAFTSMAN®

HOW TO USE THIS MANUAL

This manual is designed to provide the customer with a means to identify the parts on his/her tractor when ordering repair parts. The illustrations may or may not represent the actual assemblies; therefore, it is not recommended to use this manual as a guide to assemble or disassemble the tractor. Some hardware and parts are drawn larger in order to more readily identify them.

Each tractor has its own model number.

The model number for your tractor can be found on the fender under the seat.

When ordering parts, always give the following information:

- Product - "Tractor"
- Model Number - "259090"
- Part Number
- Part Description

TABLE OF CONTENTS

SCHEMATIC.....	3
ELECTRICAL.....	4-5
CHASSIS AND ENCLOSURES.....	6-7
GROUND DRIVE	8-9
STEERING ASSEMBLY	10-11
ENGINE	12-13,22-29
SEAT ASSEMBLY	14
DECALS	15
MOWER LIFT	16-17
MOWER DECK	18-19
TRANSAXLE	20-21

TRACTOR - - MODEL NUMBER 917.259090

SCHEMATIC

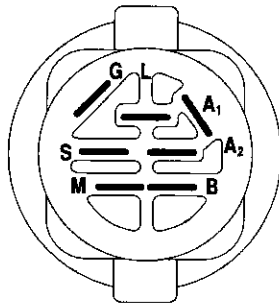
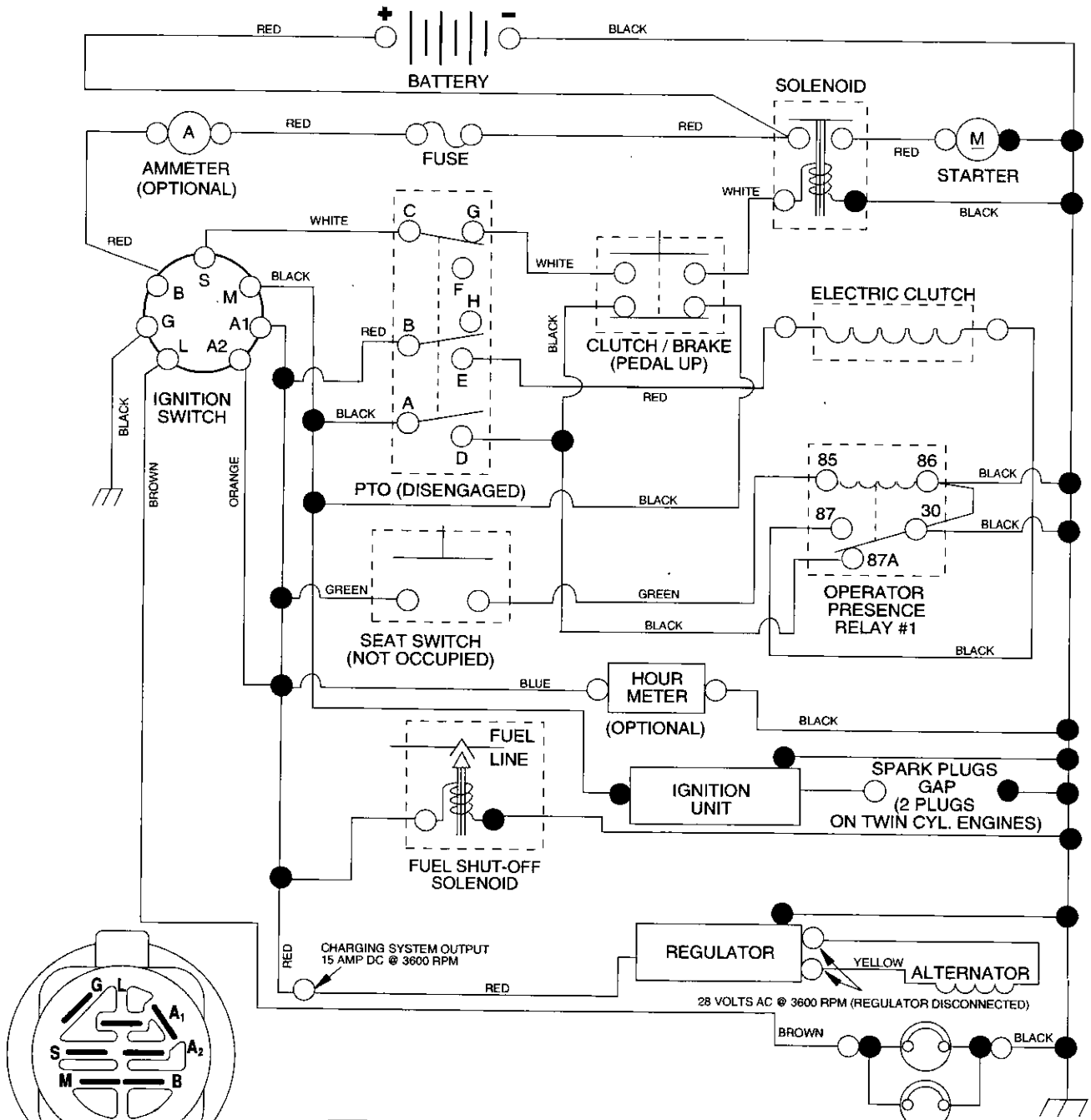

IGNITION SWITCH

POSITION	CIRCUIT	"MAKE"
OFF	M + G + A1	NONE
ON + LIGHTS	B + A1	L + A2
ON	B + A1	NONE
START	B + S + A1	NONE

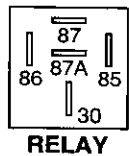

RELAY

PTO SWITCH	
POSITION	CIRCUIT
OFF	C + G, B + H
ON	C + F, B + E, A + D



REMOVABLE CONNECTIONS



NON-REMOVABLE CONNECTIONS

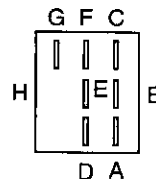

WIRING INSULATED CLIPS
NOTE: IF WIRING INSULATED CLIPS WERE REMOVED FOR SERVICING OF UNIT, THEY SHOULD BE REPLACED TO PROPERLY SECURE YOUR WIRING.

REPAIR PARTS

TRACTOR - - MODEL NUMBER 917.259090

ELECTRICAL

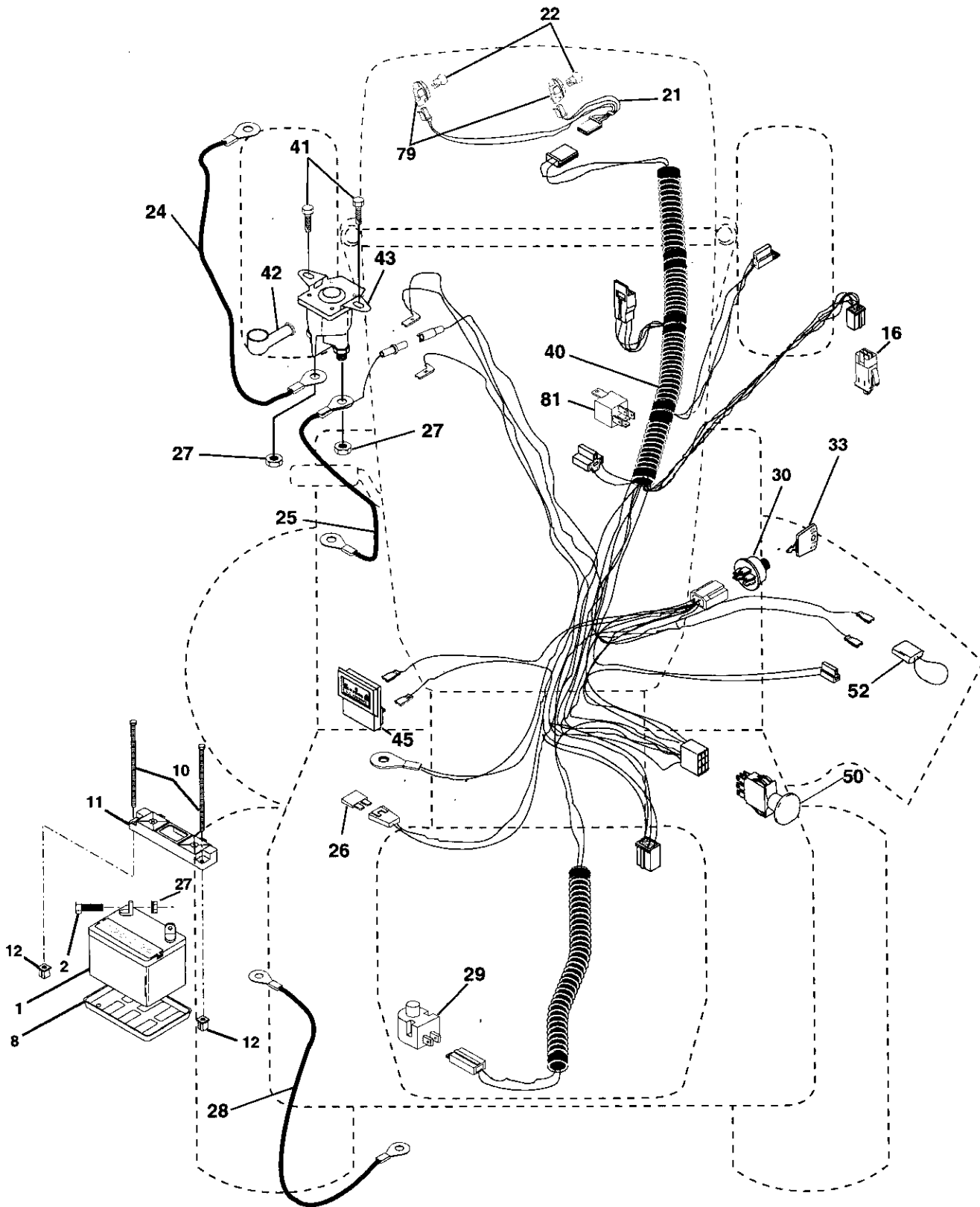

REPAIR PARTS

TRACTOR - - MODEL NUMBER 917.259090

ELECTRICAL

KEY NO.	PART NO.	DESCRIPTION
1	144927	Battery
2	74760412	Bolt Hex Head 1/4-20 x 3/4
8	7603J	Tray, Battery
10	145211	Bolt 1/4-20 x 7.5 Zinc
11	150109	Hold down Battery Dash Mount
12	145769	Nut Push Nylon 1/4"
16	153664	Switch Interlock Push-In
21	166184	Harness Socket Light W/4152J
22	4152J	Bulb Light
24	4014J	Cable, Battery
25	146686	Cable, Battery
26	108824X	Fuse
27	73510400	Nut Keps Hex 1/4-20 Unc
28	170697	Cable, Ground
29	160784	Switch, Plunger
30	163968	Switch, Ign
33	140403	Key, Ignition
40	170238	Harness Ign.
41	17720408	Screw 1/4-20 x 1/2
42	131563	Cover, Terminal
43	145673	Solenoid
45	122822X	Ammeter
50	169416	Switch, PTO
52	141940	Protection Wire Loop
79	163996	Bulbholder Asm. Incan descent
81	109748X	Relay Asm.

NOTE: All component dimensions given in U. S. inches
1 inch = 25/4 mm

REPAIR PARTS

TRACTOR - - MODEL NUMBER 917.259090

CHASSIS AND ENCLOSURES

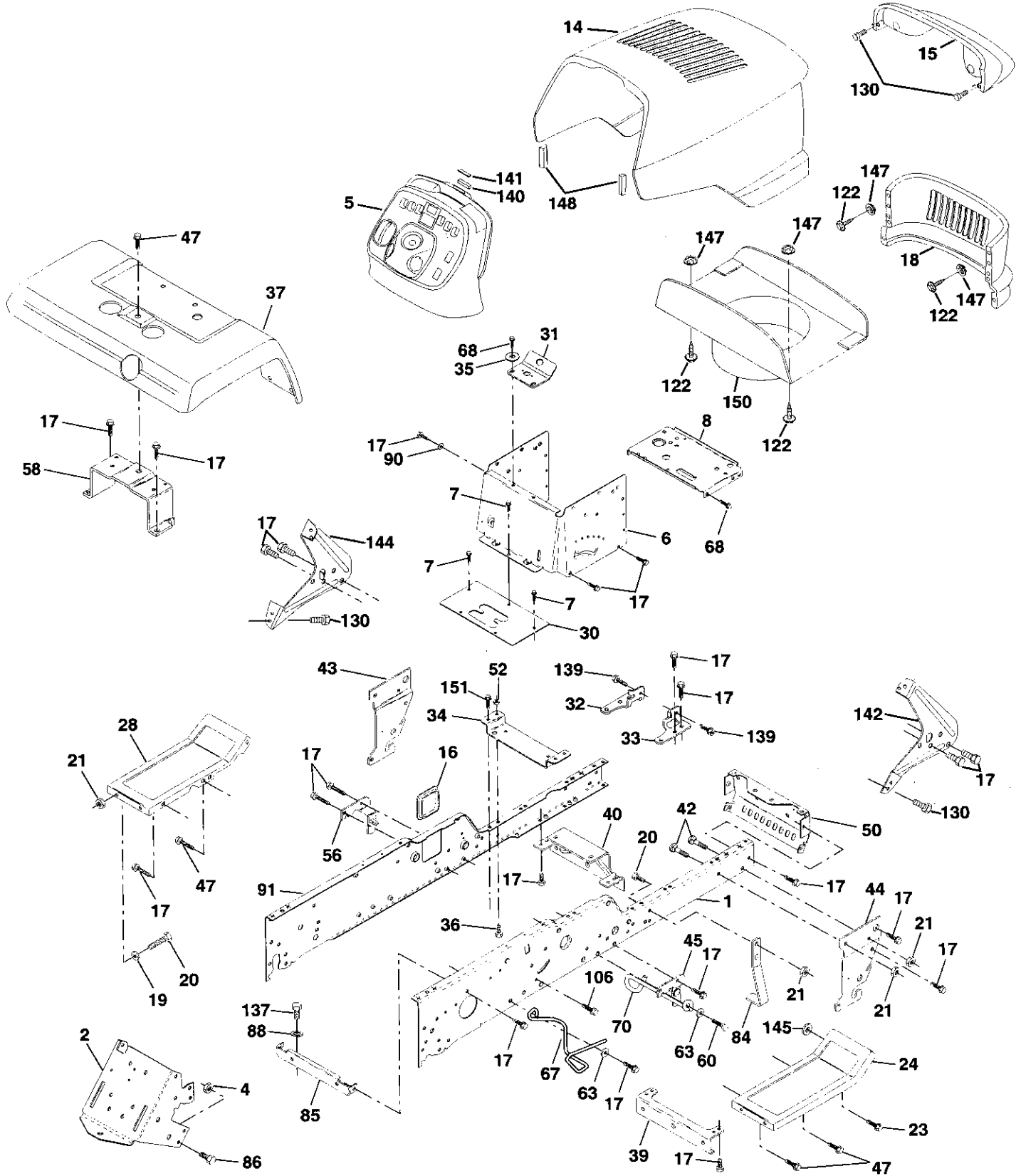

REPAIR PARTS

TRACTOR - - MODEL NUMBER 917.259090

CHASSIS AND ENCLOSURES

KEY NO.	PART NO.	DESCRIPTION	KEY NO.	PART NO.	DESCRIPTION
1	150253	Rail, Frame RH	47	17490608	Screw Thdrol. 3/8-16 x 1/2
2	140506	Drawbar, Gt	50	152728	Bracket, Chassis Front
4	73680600	Nut Crown Lock 7/16-14 Unc	52	STD541431	Nut, Crownlock 5/16-18 Unc
5	163976	Dash YTGT 2 Cyl	56	154914	Bracket Asm., Susp Chassis Lh
6	157882	Dash, Lower Vgt One Piece	58	137113	Bracket Asm., Fender
7	17720408	Screw, Thd Cut 1/4-20 x 1/2	60	17490620	Screw Thdrol. 3/8-16 x 1-1/4
8	145166	Support, Battery	63	19131614	Washer 13/32 x 1 x 14 Ga.
14	161023X558	Hood Asm., Pnt Stealth YTGT	67	156973	Guide, Belt Gear Drive
15	160568	Lens Asm Headlight Bar	68	17490508	Screw Thdrol. 5/16-18 x 1/2
16	121794X	Cover, Access	70	137159	Guide, Belt Mid Span
17	17000612	Screw	84	142992	Stop, Over Center Mower
18	160564X558	Grille	85	144911	Bracket, Support Transaxle
19	19131312	Washer 13/32 x 13/16 x 12 Ga.	86	74760716	Bolt Fin Hex 7/16-14 UNC x 1
20	STD523710	Bolt, Fin Hex 3/8-16 x 1	88	STD551143	Washer, Lock Hvy Hlcl Spr 7/16
21	STD541437	Nut Crownlock 3/8-16 Unc	90	STD551237	Washer, Lock External Tooth 3/8
23	17060616	Screw 3/8-16 x 1.5	91	170755	Rail, Frame Lh
24	145243X558	Footrest, RH	106	138776	Screw, Thdrol Hex Head Zinc wr
28	145244X558	Footrest, LH	122	161464	Screw Hex Wshd 8-18 x 7/8
30	145051X014	Saddle, Silscr Vgt	130	164863	Screw Hwhd Hi-Lo #13-16 x 3/4
31	161419	Brace, Supt 1-pc VGT Steering	137	74780716	Bolt Fin Hex 7/16-14 x 1 Gr. 5
32	161327	Bracket, Pivot Chassis Lh	139	161330	Bolt Shoulder 5/16-18 TT
33	161326	Bracket, Pivot Chassis Rh	140	163806	Magnet YTGT
34	142131	Bracket, Engine Support Rear	141	163805	Striker Plate YTGT
35	19111116	Washer 11/32 x 11/16 x 16 Ga.	142	161897	Bracket Dash Rh
36	74780512	Bolt, Fin Hex 5/16-18 x 3/4	144	161900	Bracket Dash Lh
37	167285X558	Fender	145	19131414	Washer Flat 13/32 x 7/8 x 7 Ga
39	136961	Bracket, Axle ront	147	162967	Fastener Nut Pal
40	156111	Bracket, Support Axle/Engine	150	161237	Duct Heat Hood
42	72140608	Bolt, Carriage 3/8-16 x 1	151	17060512	Screw 5/16-18 x 3/4
43	136939	Bracket, Spnsn Front Lh			
44	136940	Bracket, Spnsn Front Rh			
45	154913	Bracket Asm., Susp Chassis Rh			

NOTE: All component dimensions given in U. S. inches
1 inch = 25.4 mm

REPAIR PARTS

TRACTOR - - MODEL NUMBER 917.259090

GROUND DRIVE

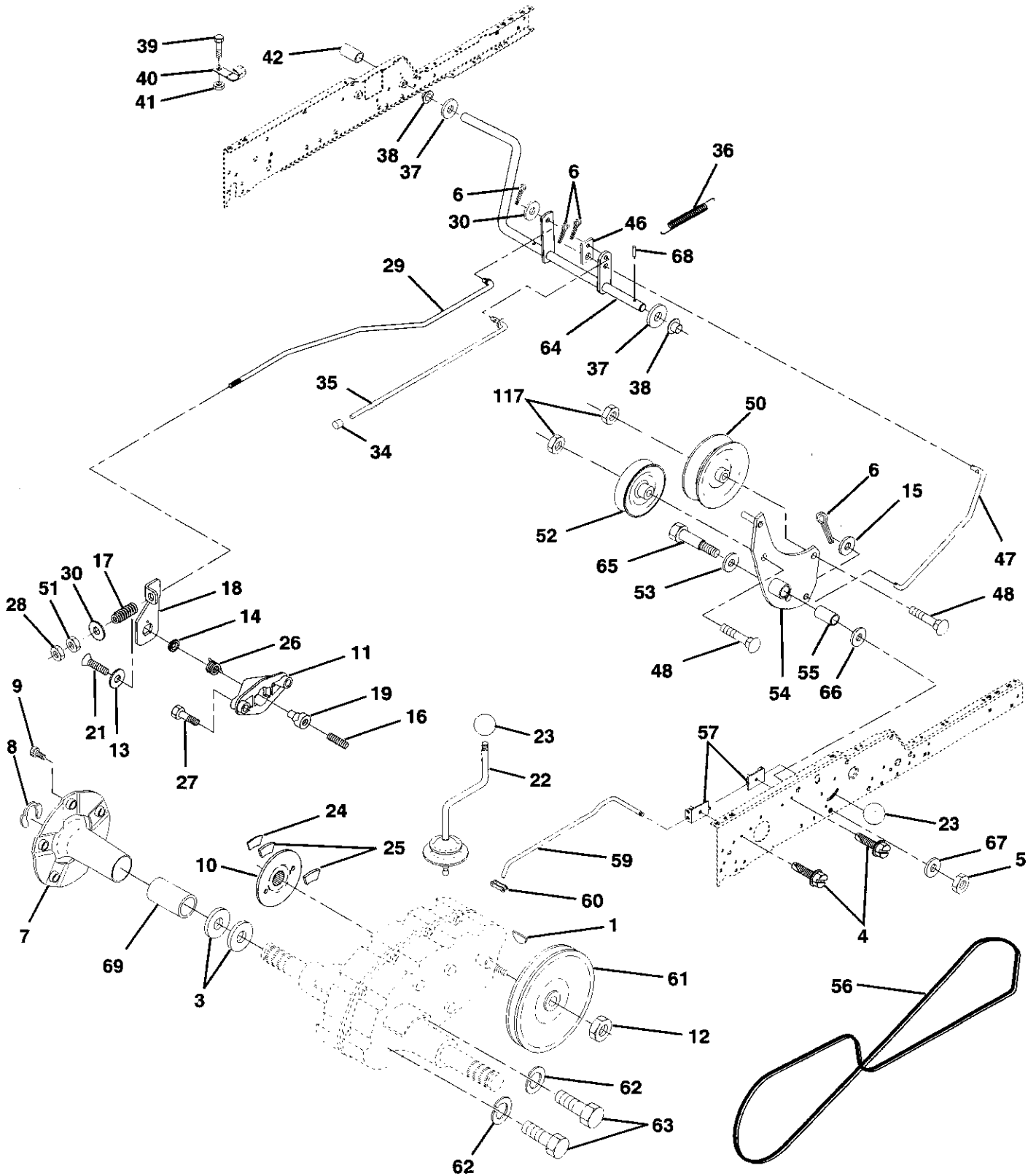

REPAIR PARTS

TRACTOR - - MODEL NUMBER 917.259090

GROUND DRIVE

KEY NO.	PART NO.	DESCRIPTION	KEY NO.	PART NO.	DESCRIPTION
1	9858M1	Key, Woodruff	36	149412	Spring, Drive Ground
3	7563R	Washer, Thrust, Axle	37	121749X	Washer 25/32 x 1-1/4 x 16 Ga.
4	17490508	Screw Thdrol 5/16-18 x 3/4	38	150035	Nyliner
5	STD541437	Nut, Crownlock 3/8-16	39	74321016	Screw, Fin. #10-24 x 1
6	STD561210	Pin, Cotter	40	5304J	Actuator, Interlock Switch
7	149176	Wheel, Hub Assembly	41	73661000	Locknut #10-24
8	12000034	Klip, Ring	42	8883R	Cover, Pedal
9	140080	Bolt, Hub	46	145170	Retainer, Spring
10	142509	Disc, Brake	47	138228	Clutch Rod
11	136927	Yoke, Brake Disc	48	72110612	Bolt, Carriage 3/8-16 x 1-1/2 Gr. 5
12	73750800	Nutlock 1/2-20 Unf	50	131494	Pulley, Idler, Flat
13	139419	Washer, Special	51	STD541437	Nut, Crownlock 3/8-16 UNC
14	138901	Bushing	52	139123	Pulley, Idler, Grooved
15	STD551037	Washer 13/32 x 13/16 x 16 Ga.	53	207J	Washer, Hardened
16	143012	Set, Screw 1/4-28 x 3/4	54	161590	Clutch, Arm Assembly
17	126909X	Spring	55	105706X	Bearing, Idler
18	137104	Lever, Brake	56	137153	V-Belt
19	136926	Cam, Brake Disc	57	141756	Bracket, Shift Rod, Hi-Lo
21	23260412	Screw, Flat Head 1/4-28 x 3/4	59	122253X	Shift Rod, Hi-Lo
22	633A109	Gearshift, Lever Assembly	60	122268X	Spring Clip, Connecting Link
23	106932X	Knob	61	137524	Pulley, Transaxle
24	136925	Support, Puck Brake	62	STD551143	Washer, Lock 7/16
25	136923	Puck, Brake Top	63	74760720	Bolt, Fin Hex 7/16-14 x 1-1/4
26	137552	Spring, Return	64	154752	Shaft, Clutch/Brake Pedal
27	17490528	Screw, Hex Wsh Thd. 5/16-18 x 1-3/4	65	67609	Bolt, Shoulder
28	73350600	Nut, Hex Jam 3/8-16	66	140296	Washer, Hardened
29	137213	Brake, Rod	67	19131312	Washer, Flat
30	19131616	Washer 13/32 x 1 x 16 Ga.	68	5142H	Pin, Roll
34	71673	Cap, Plunger	69	136327	Hub, Cover
35	137648	Rod, Parking Brake	117	73900600	Nut, Lock Flg. 3/8-16 Unc

NOTE: All component dimensions given in U. S. inches
1 inch = 25.4 mm

REPAIR PARTS

TRACTOR - - MODEL NUMBER 917.259090

STEERING ASSEMBLY

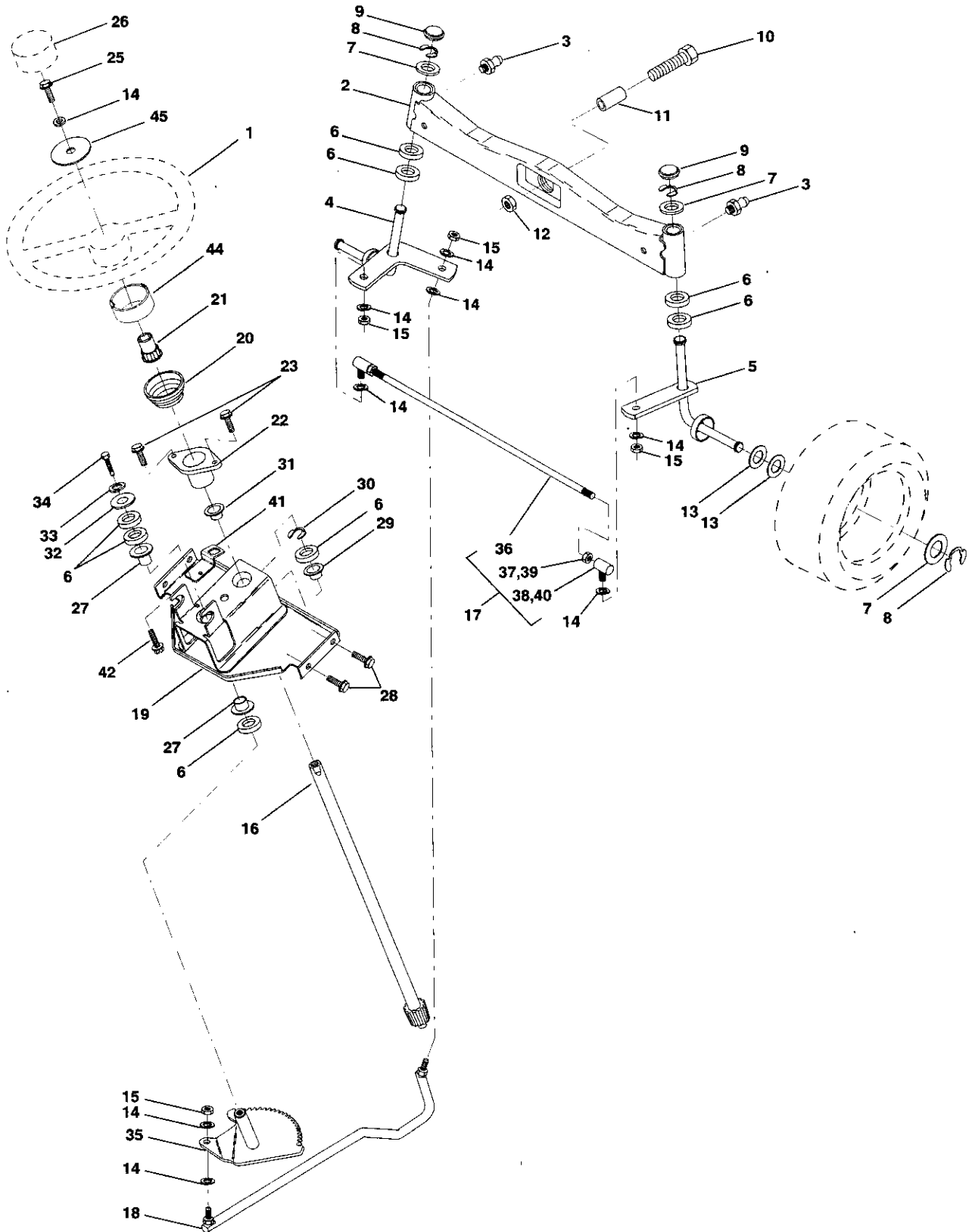

REPAIR PARTS

TRACTOR - - MODEL NUMBER 917.259090

STEERING ASSEMBLY

KEY NO.	PART NO.	DESCRIPTION
1	139768	Wheel, Steering
2	137094	Axle Asm., Front
3	6855M	Fitting, Grease
4	161849	Spindle Asm, LH
5	161848	Spindle Asm., RH
6	6266H	Bearing, Race Thrust Harden
7	121748X	Washer 25/32 x 1-5/8 x 16 Ga.
8	12000029	Ring, Klip #T5304-75
9	121232X	Cap, Spindle
10	74781044	Bolt, Fin Hex 5/8-11 x 2-3/4
11	136518	Spacer Bearing Axle Front
12	73901000	Nut, Lock Flange 5/8-11 Unc
13	121749X	Washer 25/32 x 1-1/4 x 16 Ga.
14	STD551137	Washer, Lock Hvy Hlcl Spr 3/8
15	STD541537	Nut, Lock Center 3/8-24 UNF
16	145103	Shaft Asm., Steering
17	137347	Rod Asm., Tie Ball J Ball Vgt Inc. Key No. 36-40)
18	137155	Draglink, Ball Joint Solid Vgt
19	156011	Support Asm., Steering Vgt
20	172020	Boot, Steering
21	100711L	Adapter, Wheel Steering
22	155105	Bushing, Strg. Blk
23	152927	Screw
25	STD523710	Bolt, Fin Hex 3/8-16 x 1 Gr. 5
26	139769	Cap, Wheel Steering
27	3366R	Bearing, Col. Strg.
28	17000612	Screw Hex Wsh Thdrol 3/8-16
29	104239X	Bearing, Flange
30	12000034	Ring, Klip Truarc #5304-75
31	138136	Bushing, Nyliner Snap
32	19111610	Washer 11/32 x 1 x 10 Ga.
33	STD551131	Washer, Lock Hvy Hlcl Spr 5/16
34	STD523107	Bolt, Hex Hd 5/16-18 x 3/4
35	138059	Gear, Sector Steering
36	137156	Tie Rod
37	73360600	Jam Nut RH Thread
38	109850X	Joint Asm. Ball RH Thread
39	73700600	Jam Nut LH Thread
40	109851X	Joint Asm. Ball LH Thread
41	155246	Bracket Switch Interlock VGT 97
42	17490508	Screw Thdrol 5/16-18 x 1/2 Tyt
44	160135	Extension, Steering
45	19133812	Washer 13/32 x 2-3/8 x 12 Ga.

NOTE: All component dimensions given in U.S.
inches 1 inch = 25.4 mm

REPAIR PARTS

TRACTOR - - MODEL NUMBER 917.259090

ENGINE

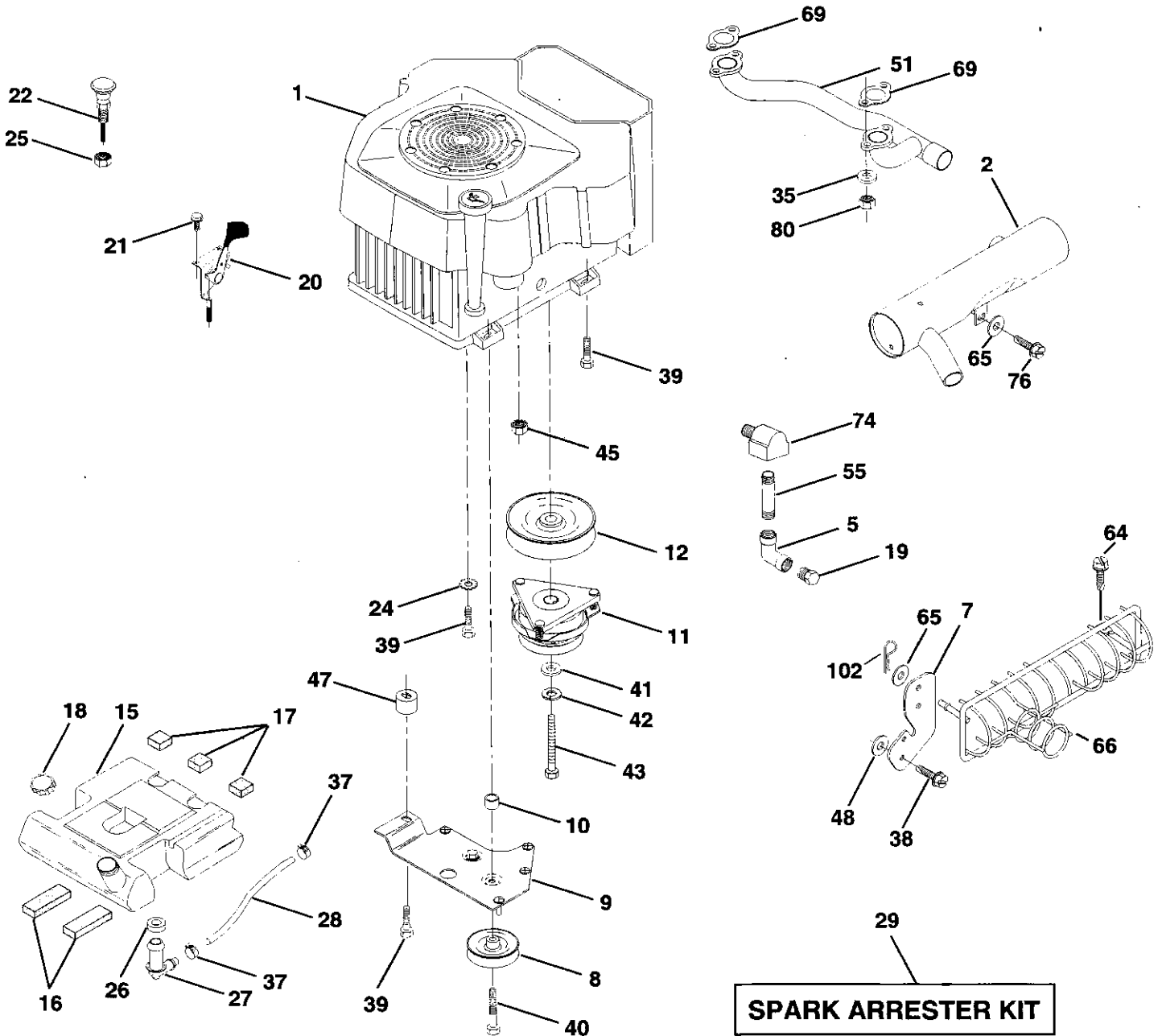

REPAIR PARTS

TRACTOR - - MODEL NUMBER 917.259090

ENGINE

KEY NO.	PART NO.	DESCRIPTION
1	-----	Engine (See Breakdown) Kohler Model No. CV20S-65563
2	161063	Muffler Side
5	13200300	Elbow STD 90 Degree 3/8 - 18 NPT
7	151397	Muffler Asm Guard
8	121361X	Pulley V-Idler
9	150828	Keeper Asm. Belt Engine
10	105432X	Bushing
11	140923	Clutch Electric
12	143996	Pulley Engine VGT Elect Clutch
15	151346	Tank Fuel Rear 3.50 Yt/Gt 96
16	109227X	Pad Spacer
17	106082X	Pad Spacer
18	140527	Cap Asm Fuel
19	13290300	Plug Oil Drain (See Engine Breakdown)
20	164067	Control Throttle
21	164863	Screw HWHD Hi-Lo #13-16 x 3/4
22	164415	Control Choke
24	STD551237	Washer Ext Tooth 3/8
25	73920600	Nut Keps 3/8 - 24 UNF
26	3645J	Bushing
27	139277	Stem Tank Fuel
28	7834R	Fuel Line
29	132920	Spark Arrester Kit
35	10010500	Washer Split
37	123487X	Clamp Hose
38	17060620	Screw 3/8-16 x 1-1/4
39	17490636	Screw TT 3/8-16 x 2-1/4 UNC
40	17490664	Screw TT 3/8-16 x 4 UNC
41	126197X	Washer 1-1/2 OD X 15/32 ID X .250
42	STD551143	Washer Lock 7/16
43	150280	Bolt Hex 7/16 - 20 X 4 - 1/4 Ga 5
45	73510400	Nut Keps Hex 1/4-20 Unc
47	142040	Spacer Engine
48	19132007	Washer 13/32 x 1-1/4 x 7 Ga.
51	161231	Manifold Pipe VGT
55	13280336	Nipple Pipe 4-1/2
64	17060616	Screw 3/8-16 x 1.5
65	19131614	Washer 13/32 x 1 x 14 Ga.
66	153113	Cage Muffler
69	24-041-02	Gasket
74	162295	Elbow Street Brass
76	17490612	Screw Thdrol 3/8-16 x 3/4 Ty-TT
80	M73030800	Nut Flange
102	STD624003	Retainer Spring 1" Zinc 1 Cad

NOTE: All component dimensions given in U. S. inches
1 inch = 25.4 mm

REPAIR PARTS

TRACTOR - - MODEL NUMBER 917.259090

SEAT ASSEMBLY

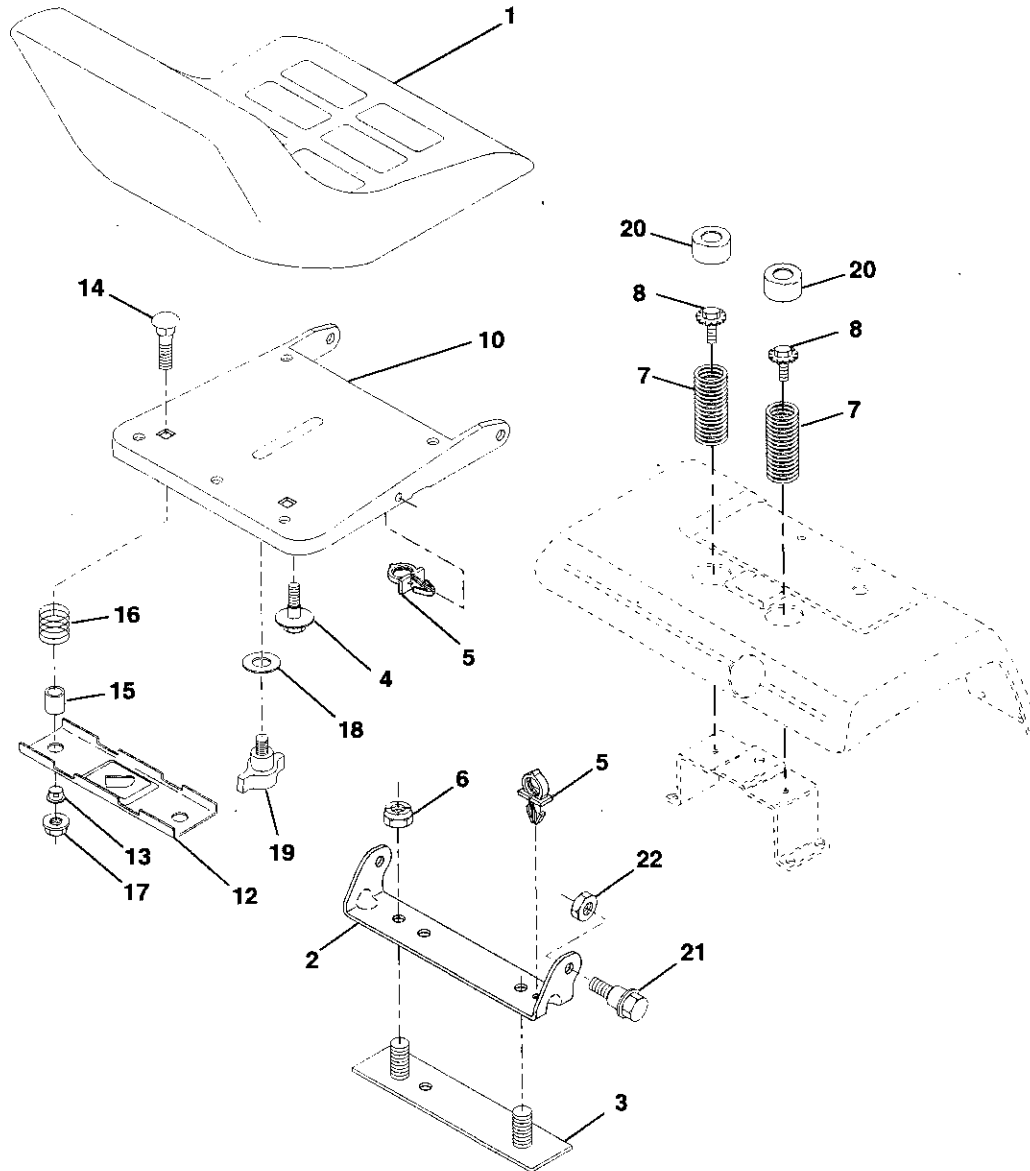

KEY NO.	PART NO.	DESCRIPTION
1	140123	Seat
2	140551	Bracket, Pivot Seat
3	140675	Strap, Fender
4	127018X	Bolt, Shoulder 5/16-18 x .62
5	145006	Clip, Push In, Hinged
6	STD541437	Nut, Crownlock 3/8-16 Unc
7	124181X	Spring, Seat Cprsn
8	171877	Bolt 5/16-18 Unc x 3/4 w/Sems
10	155925	Pan, Seat
12	121246X	Bracket, Mounting Switch
13	121248X	Bushing, Snap

KEY NO.	PART NO.	DESCRIPTION
14	72050412	Bolt, Carriage 1/4-20 X 1-1/2
15	134300	Spacer, Split
16	121250X	Spring, Cprsn
17	123976X	Nut, Lock 1/4 Lge Flg Gr. 5
18	19171912	Washer 17/32 x 1-3/16 x 12 Ga.
19	166369	Knob, Seat
20	124238X	Cap, Spring Seat
21	171852	Bolt, Shoulder 5/16-18
22	STD541431	Nut, Crownlock 5/16-18 Unc

NOTE: All component dimensions given in U.S. inches
1 inch = 25.4 mm

REPAIR PARTS

TRACTOR - - MODEL NUMBER 917.259090

DECALS

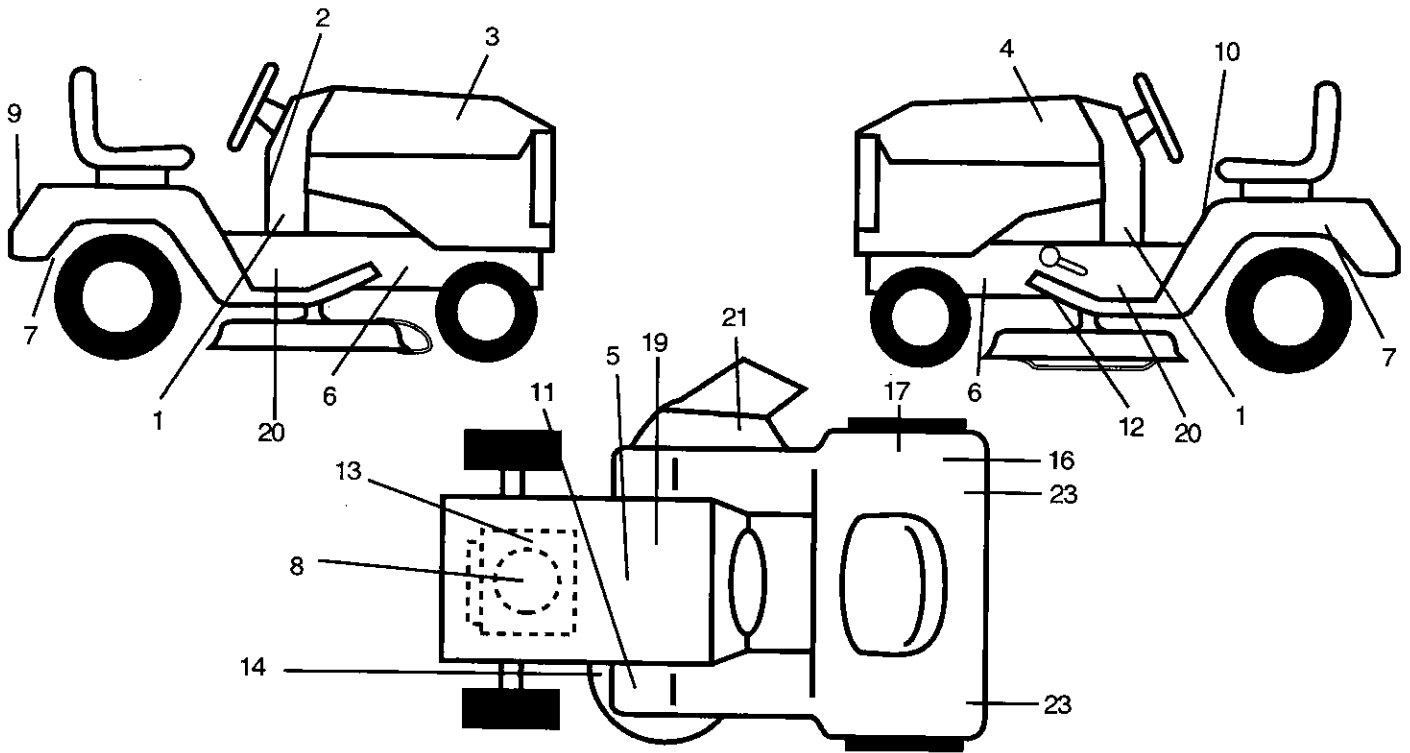

KEY NO.	PART NO.	DESCRIPTION
1	163265	Decal, Dash Panel
2	164487	Decal, Dash Ammeter
3	171702	Decal, Hood, Craftsman, RH
4	171703	Decal, Hood, Craftsman, LH
5	145005	Decal, Battery DNGR/PSN
6	159736	Decal, Hot Muffler
7	163210	Decal, Fender
8	164757	Decal, Engine
9	163204	Decal, Fender, Craftsman
10	145498	Decal, Read Owner's Manual
11	159737	Decal, Clutch/Brake
12	146047	Decal, V-Belt Drive Schematic
13	164884	Decal, Blower Housing
14	160397	Decal, V-Belt Schematic

KEY NO.	PART NO.	DESCRIPTION
16	126187X	Decal, Certification
17	145437	Decal, Europe Stand CE
19	138047	Decal, Battery
20	171705	Decal, Side Panel
21	133179	Decal, Mower
23	106202X	Reflector, Taillight
--	138311	Decal, Handle Lft Height Adjust (Lift Handle)
--	157199X428	Pad, Footrest
--	162598	Decal, Drawbar Load Limit
--	173896	Manual, Oper (Euro)
--	173897	Manual, Oper (Scandi)
--	174092	Manual, Parts

WHEELS AND TIRES

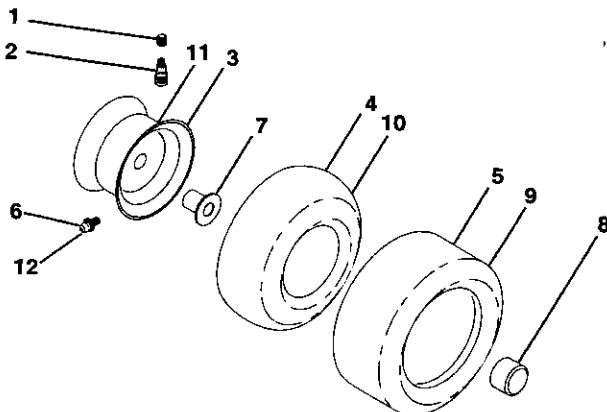

KEY NO.	PART NO.	DESCRIPTION
1	59192	Cap, Valve, Tire
2	65139	Stem, Valve
3	106228X427	Rim Assembly, Front
4	8134H	Tube, Front (Service Item Only)
5	106230X	Tire, Front
6	278H	Fitting, Grease (Front Wheel Only)
7	9040H	Bearing, Flange (Front Wheel Only)
8	104757X	Cap, Axle (Front Wheel Only)
9	106230X	Tire, Rear
10	7154J	Tube, Rear (Service Item Only)
11	106277X427	Rim Assembly, Rear
12	6856M	Fitting, Grease
--	144334	Sealant, Tire (10 oz. Tube)

NOTE: All component dimensions given in U.S. inches
1 inch = 25.4 mm

REPAIR PARTS

TRACTOR - - MODEL NUMBER 917.259090

MOWER LIFT

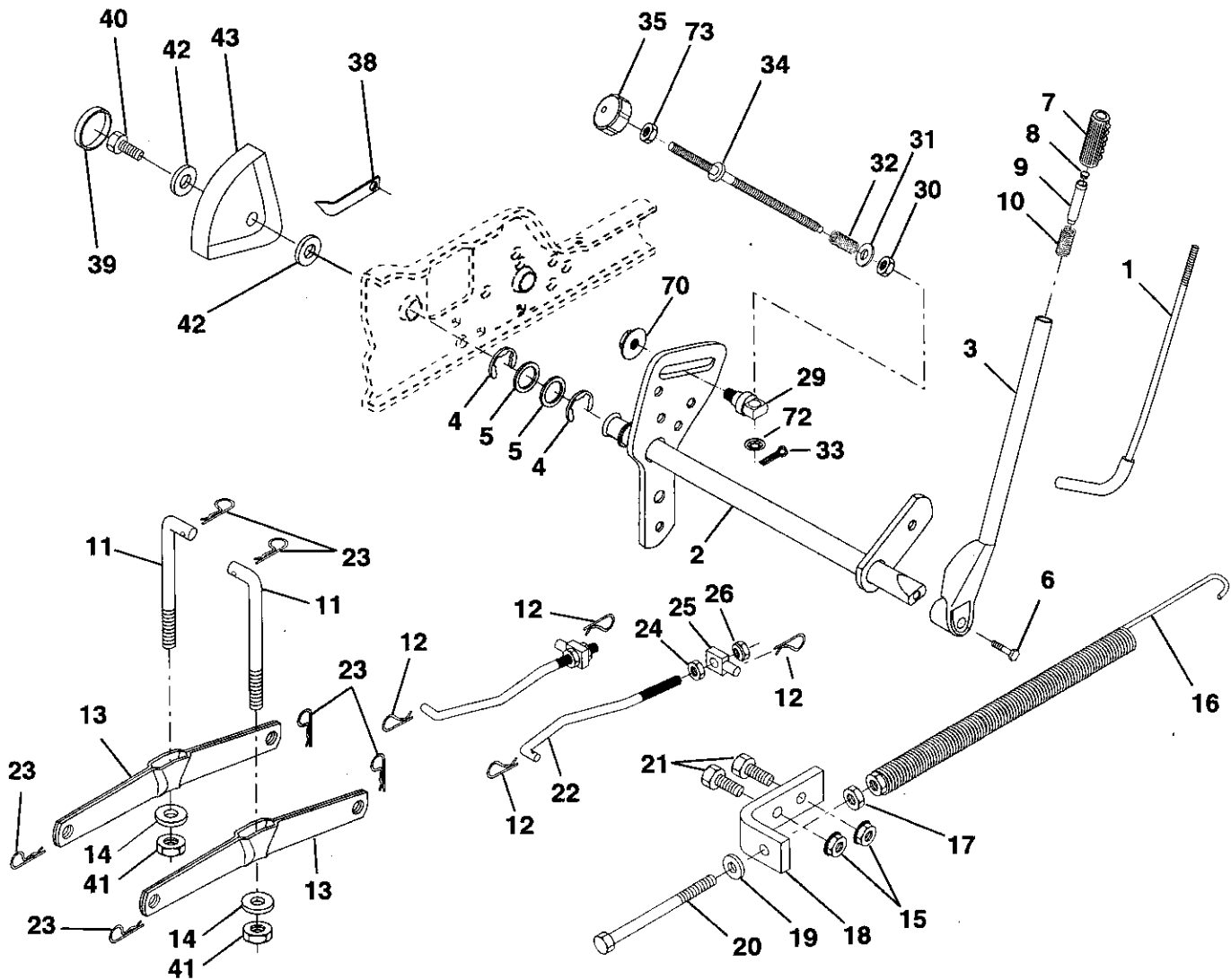

REPAIR PARTS

TRACTOR - - MODEL NUMBER 917.259090

MOWER LIFT

KEY NO.	PART NO.	DESCRIPTION
1	121006X	Rod Asm., Lever
2	159187	Shaft Asm., Lift Vgt
3	159189	Lever Asm., Lift Rh
4	12000022	E-Ring Truarc #5133-87
5	19292016	Washer 29/32 x 1-1/4 x 16 Ga.
6	71110624	Bolt, Fin Hex 3/8-16 Unc x 1-1/2
7	125631X	Grip, Handle Fluted
8	122365X	Button, Plunger
9	122364X	Plunger, Button
10	2876H	Spring 2-1/8"
11	146704	Link Lift
12	163552	Retainer, Spring
13	139868	Arm, Suspension Vgt
14	140302	Bearing
15	STD541437	Nut, Crownlock 3/8-16 Unc
16	674A247	Spring Asm., Assist Lift
17	STD541237	Nut, Hex Jam 3/8-16 Unc
18	143363	Bracket, Spring Assist
19	STD551037	Washer 13/32 x 13/16 x 16 Ga.
20	5328J	Bolt, Adjust Spring Assist
21	STD523710	Bolt, Fin Hex 3/8-16 x 1
22	127218	Link, Front
23	STD624008	Retainer, Spring
24	73350800	Nut, Jam Hex 1/2-13 Unc
25	130171	Trunnion
26	73680800	Nut, Crownlock 1/2-13 Unc
29	150233	Trunnion, Infin Height
30	110807X	Nut, Special
31	19131016	Washer 13/32 x 5/8 x 16 Ga.
32	137150	Spring, Compression Inf Hgt
33	STD560907	Pin, Cotter 3/32 x 1/2
34	137167	Rod, Adj Lift
35	138057	Knob, Inf 3/8-16 Unc
38	155097	Pointer, Height Indicator
39	123935X	Plug, Hole
40	17060516	Screw 5/16-18 x 1
41	73540600	Nut, Crownlock 3/8-24
42	19112410	Washer 11/32 x 1-1/2 x 10 Ga.
43	123934X	Scale, Indicator Height
70	145212	Nut Hex Flange Lock
72	110452X	Nut Push Phos & Oil

NOTE: All component dimensions given in U. S. inches 1 inch = 25.4 mm

REPAIR PARTS

TRACTOR - - MODEL NUMBER 917.259090

MOWER DECK

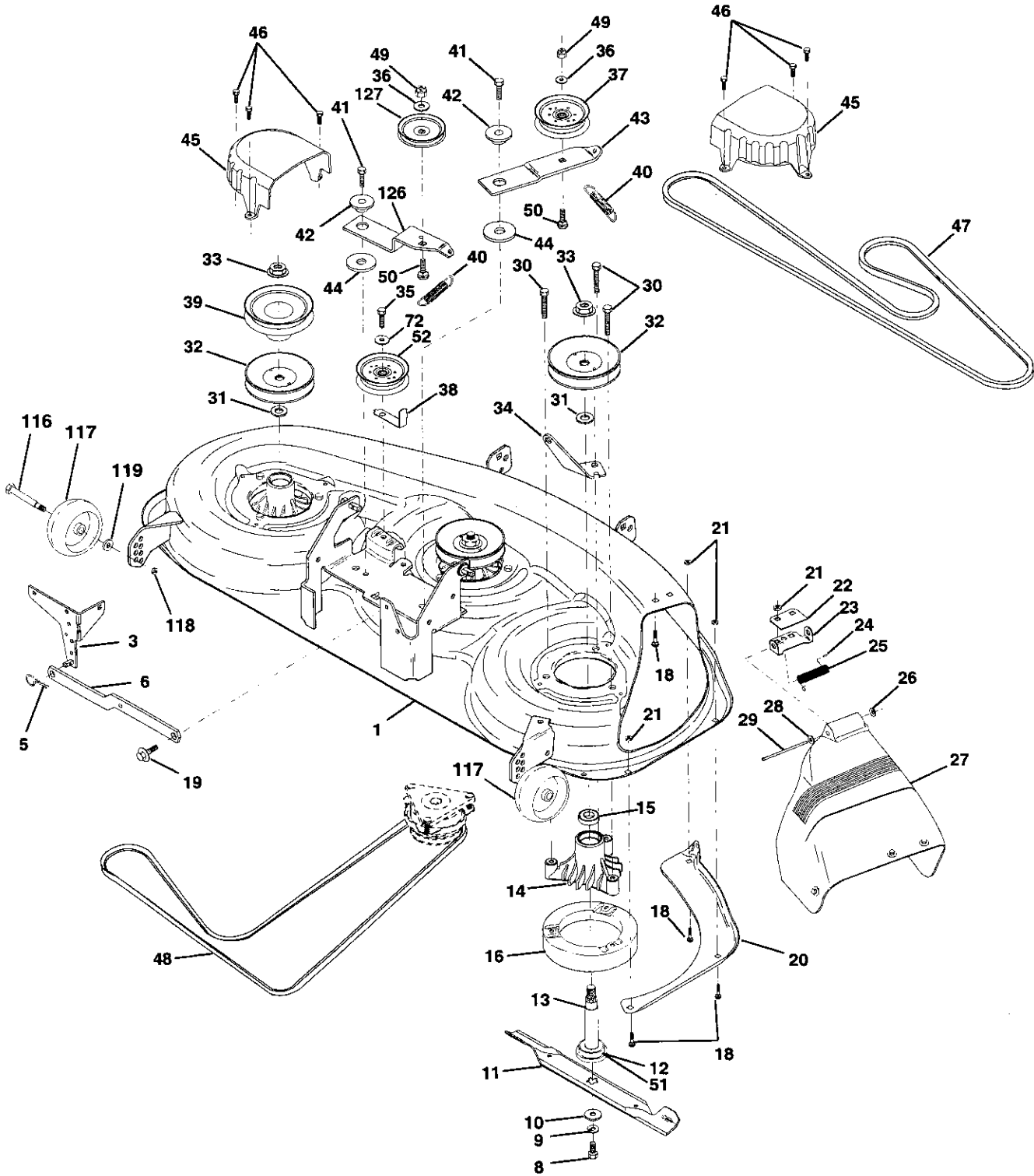

REPAIR PARTS

TRACTOR - - MODEL NUMBER 917.259090

MOWER DECK

KEY NO.	PART NO.	DESCRIPTION	KEY NO.	PART NO.	DESCRIPTION
1	156948	Deck Weldment	37	131494	Pulley, Idler, Flat
3	138457	Bracket Asm., Sway Bar	38	156086	Keeper, Belt, Idler
5	STD624008	Retainer Spring	39	144917	Pulley, Idler, Driven
6	130832	Arm, Suspension, Rear (Sway Bar)	40	137273	Spring, Secondary 44/46/50 Vent
8	850857	Bolt, Patched 3/8-24 x 1-1/4 Gr. 8	41	17060620	Screw 3/8-16 x 1-1/4
9	STD551137	Washer, Lock Hvy., Unplated 3/8	42	165723	Spacer, Retainer
10	140296	Washer, Hard Blade, Mower Vented	43	144949	Arm, Idler Secondary
11	170698	Blade <i>176084</i>	44	133943	Washer, Hardened
12	129895	Bearing, Ball, Mandrel #6204	45	145059	Cover, Mandrel Deck
13	137553	Shaft Asm. w/Lower Bearing (Includes Key No. 12)	46	137729	Screw, Thdroll. 1/4-20 x 5/8
14	137152	Housing, Mandrel	47	144959	V-Belt, Mower, Secondary
15	110485X	Bearing, Ball, Mandrel	48	148763	V-Belt, Mower, Primary
16	140329	Stripper, Mower Round	49	STD541437	Nut, Crownlock 3/8-16 UNC
18	STD533106	Bolt, Carriage 5/16-18 x 5/8	50	72110612	Bolt, Carriage 3/8-16 x 1-1/2 Gr. 5
19	132827	Bolt, Hex Head, Shoulder 5/16-18	51	153390	Washer Felt
20	145055	Baffle, Vortex Mower 46"	52	156493	Pulley Idler 46" Prim. Drive
21	STD541431	Nut, Crownlock 5/16-18 UNC	72	19131616	Washer 13/32 x 1 x 16 Ga.
22	134753	Stiffener, Bracket	116	137644	Bolt, Shoulder
23	131267	Bracket, Deflector	117	133957	Gauge Wheel
24	105304X	Cap, Sleeve	118	73930600	Nut, Centerlock 3/8-16 UNC
25	149287	Spring, Torsion, Deflector	119	19121414	Washer 3/8 x 7/8 x 14 Ga.
26	110452X	Nut, Push	126	144948	Arm, Idler, Primary Deck 46"
27	166883X428	Deflector Clipping	127	146763	Pulley, Idler, V-Groove Dim. 4.25
28	19111016	Washer 11/32 x 5/8 x 16 Ga.	--	166209	Mower Service 46" (Standard Deck - Order separately mulching components Key Nos. 101-106)
29	131491	Rod, Hinge	--	143651	Mandrel Asm 44/50 Service (Includes Key Nos. 8-10, 12-15, 31 and 33)
30	157722	Screw, Thd Rolling Washer Head			
31	129963	Washer, Spacer Mower Vented			
32	153531	Pulley, Mandrel			
33	137266	Nut, Flg. Top Lock Cntr. 9/16			
34	144945	Anchor, Spring Deck 46"			
35	17490628	Screw, Thdroll 3/8-16 x 1-3/4 Tytt			
36	STD551037	Washer 13/32 x 13/16 x 16 Ga.			

NOTE: All component dimensions given in U.S. inches
1 inch = 25.4 mm

REPAIR PARTS

TRACTOR - - MODEL NUMBER 917.259090

TRANSAXLE

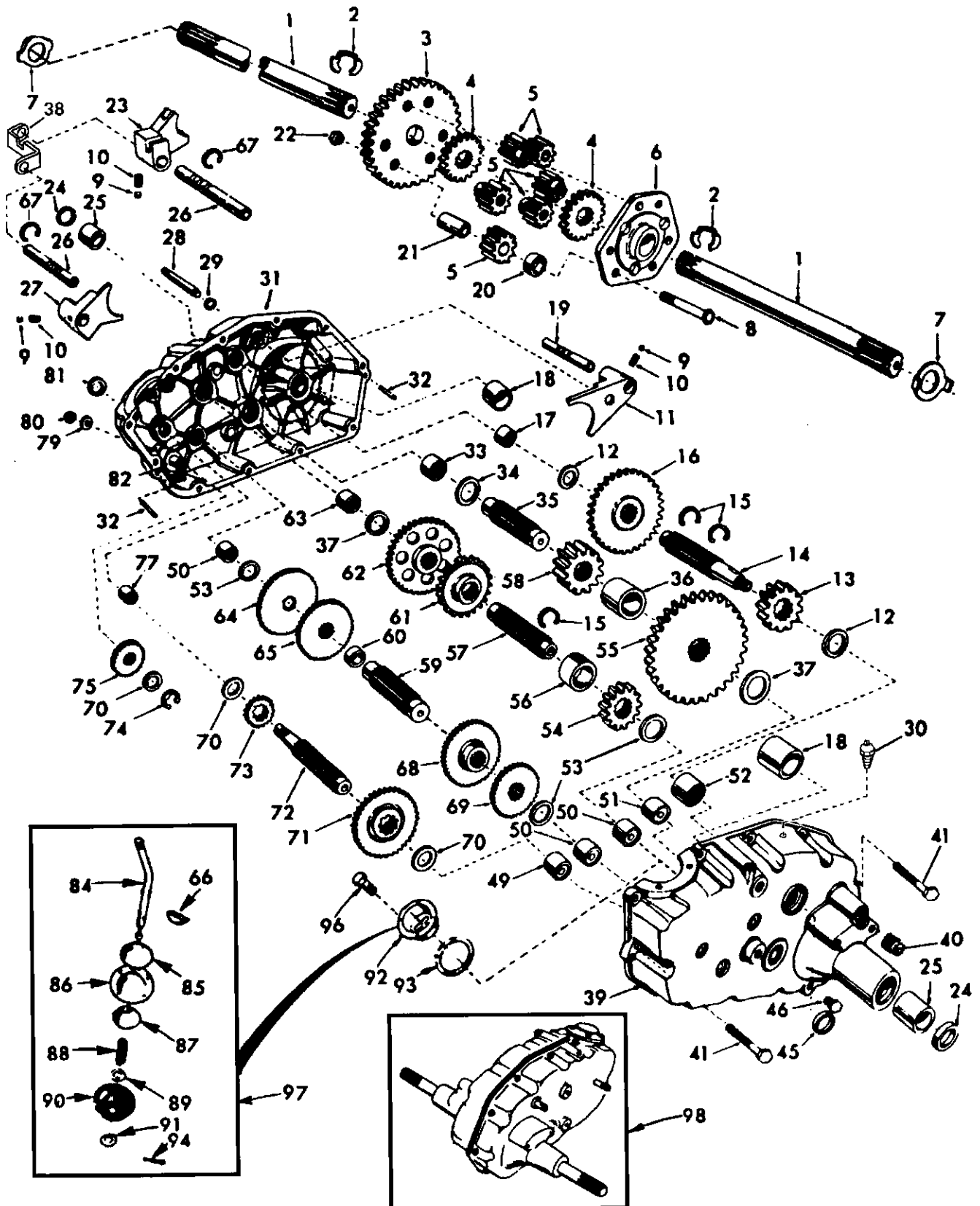

REPAIR PARTS

TRACTOR - - MODEL NUMBER 917.259090

TRANSAXLE

KEY NO.	PART NO.	DESCRIPTION	KEY NO.	PART NO.	DESCRIPTION
1	4197R	Axle Shaft	52	8119M	Needle Bearing
2	12000034	Retaining Ring	53	4220R	Thrust Bearing Race
3	4199R	Final Drive Gear	54	4209R	3rd Reduction Pinion, Low
4	4216R	Differential Gear	55	4213R	4th Reduction Gear
5	4215R	Differential Pinion	56	4442R	3rd Reduction Pinion Spacer
6	4217R	Differential Carrier	57	4195R	2nd Reduction Gear Shaft
7	6256H	Axle Thrust Washer	58	4214R	Final Drive Pinion
8	74020652	Bolt, Hex Head 3/8-24 x 3-1/4 (1" Thread Length)	59	4194R	1st Reduction Gear Shaft
9	7392M	Steel Ball	60	7528R	1st Reduction Shaft Spacer
10	137261	Spring Shift Fork Detent	61	4208R	3rd Reduction Pinion High
11	4985R	Shift Fork, High-Low Range	62	4207R	2nd Reduction Gear
12	6266H	Thrust Bearing Race	63	7398H	Needle Bearing
13	4212R	4th Reduction Pinion	64	4203R	Low Speed Gear and 2nd Reduction Pinion Cluster
14	137125	Shaft, Brake	65	4204R	Reverse Gear
15	6276H	Snap Ring, Crescent Type	66	2898J	Key, Hi-Pro 1/8 x 17/32
16	633A63	High-Low Range Gears	67	12000033	Klip Ring
17	8118M	Needle Bearing	68	4205R	Intermediate Speed Gear
18	8740H1	Sintered Iron Bearing	69	4206R	High Speed Gear
19	122238X	Shift Fork Shaft, High-Low Range	70	1370H	Thrust Bearing Race
20	4218R	Differential Pinion Spacer	71	633A69	Intermediate and High Speed Cluster Pinions
21	6252H1	Differential Pinion Bushing	72	139120	Input Shaft
22	7810H	Gripco Centerlock Nut 3/8-24	73	4201R	Low Speed Pinion
23	6262H	Shift Fork, R.H.	74	12000008	E-Ring
24	7393R	Oil Seal	75	1153R	Reverse Idler Gear
25	992R1	Sintered Iron Bearing	77	6803J	Needle Bearing
26	139111	Shift Fork Shaft	79	1167R	Sealing Washer
27	4986R	Shift Fork, L.H.	80	73360700	Nut, Hex, Jam 7/16-20
28	122254X	Shift Shaft, High-Low Range	81	6270H	Oil Seal
29	6269H	Oil Seal	82	136984	Reverse Idler Shaft
30	5855H	Pressure Relief Valve	84	5384J	Gearshift Lever, Bent
31	139538	Gearcase, Reverse Idler Shaft and Bearings, R.H. (Includes Key No.'s 17, 18, 25, 33, 50, 63, 77 and 82)	85	2978J	Gearshift Cap
32	6277H	Dowel Pin	86	633A85	Gearshift Ball Cover and Pin
33	4225R	Needle Bearing	87	8739H1	Shift Lever Guide Ball, Keyed
34	7396H	Thrust Bearing Race	88	4924H	Spring
35	4198R	4th Reduction Gear Shaft	89	19151516	Washer 15/32 x 15/16 x 16 Gauge
36	4200R	4th Reduction Gear Spacer	90	110542X	Shift Mechanism Seal
37	7395H	Thrust Bearing Race	91	19181511	Washer 9/16 x 15/16 x 12 Gauge
38	160789	Gate, Lower, Shift	92	75J	Gearshift Gate and Reinforcement
39	139536	Gearcase and Bearings, L.H. (Includes Key Numbers 18, 25, 49, 50 (2), 51 and 52)	93	6274H	Shift Ball Cover Gasket
40	13320400	Pipe Plug 1/2-14 N.P.T.	94	76020412	Cotter Pin 1/8 x 3/4
41	17580520	Bolt, Hex 5/16-18 UNC x 1-1/4	96	159783	Screw, Hex, Washer, HD.
45	6271H	Oil Seal	97	633A109	Gearshift Lever Assembly
46	13060200	Pipe Plug 1/4-18 N.P.T.	98	161823	Transaxle, 6 Speed, Complete Assembly
49	4895H	Needle Bearing			
50	4222R	Needle Bearing			
51	1529R	Needle Bearing			

NOTE: All component dimensions given in U.S. inches
1 inch = 25.4 mm

REPAIR PARTS

TRACTOR - - MODEL NUMBER 917.259090

KOHLER ENGINE - MODEL NUMBER CV20S, TYPE NUMBER 65563

CYLINDER HEAD, VALVE AND BREATHER

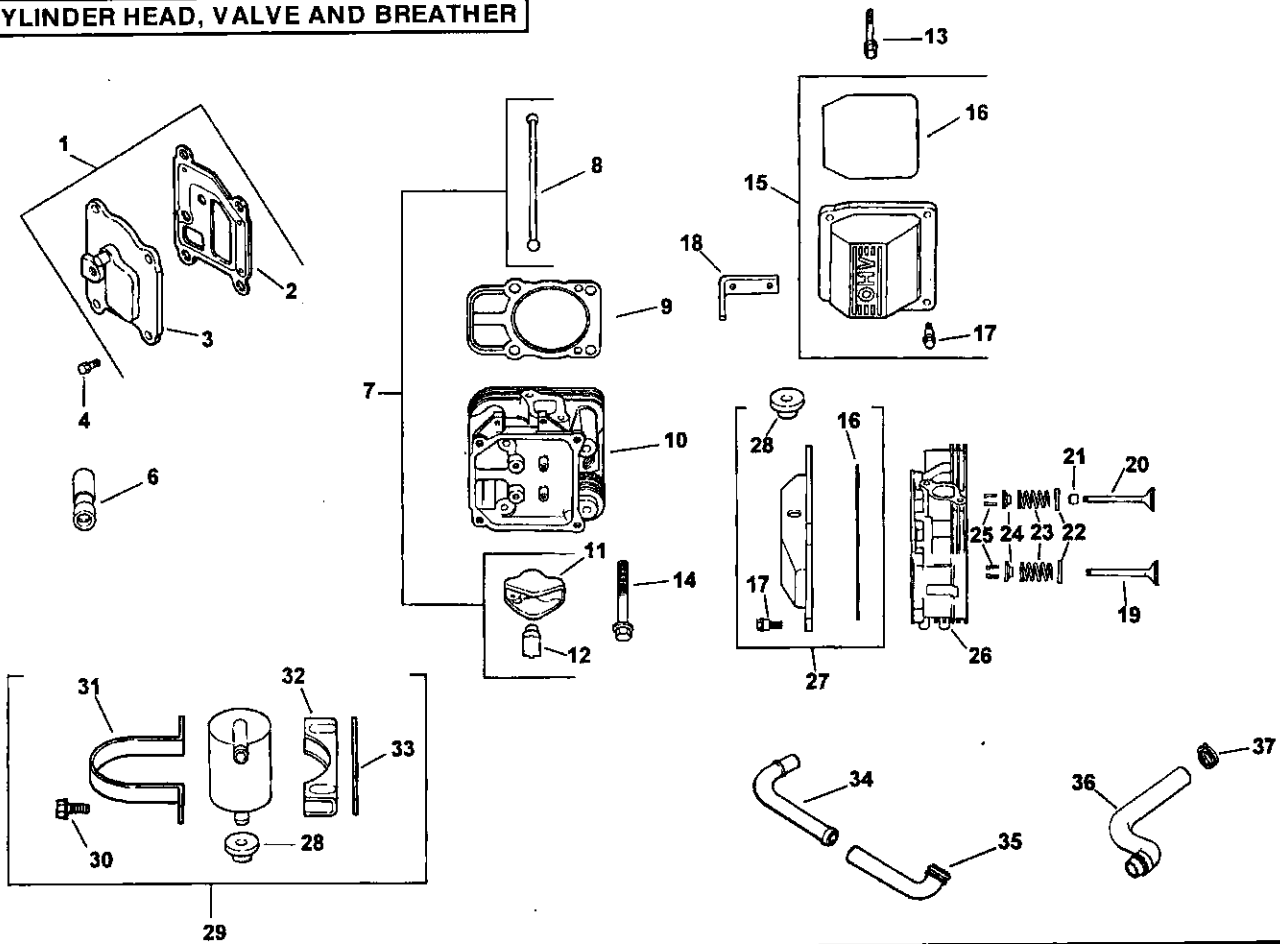

CRANKCASE

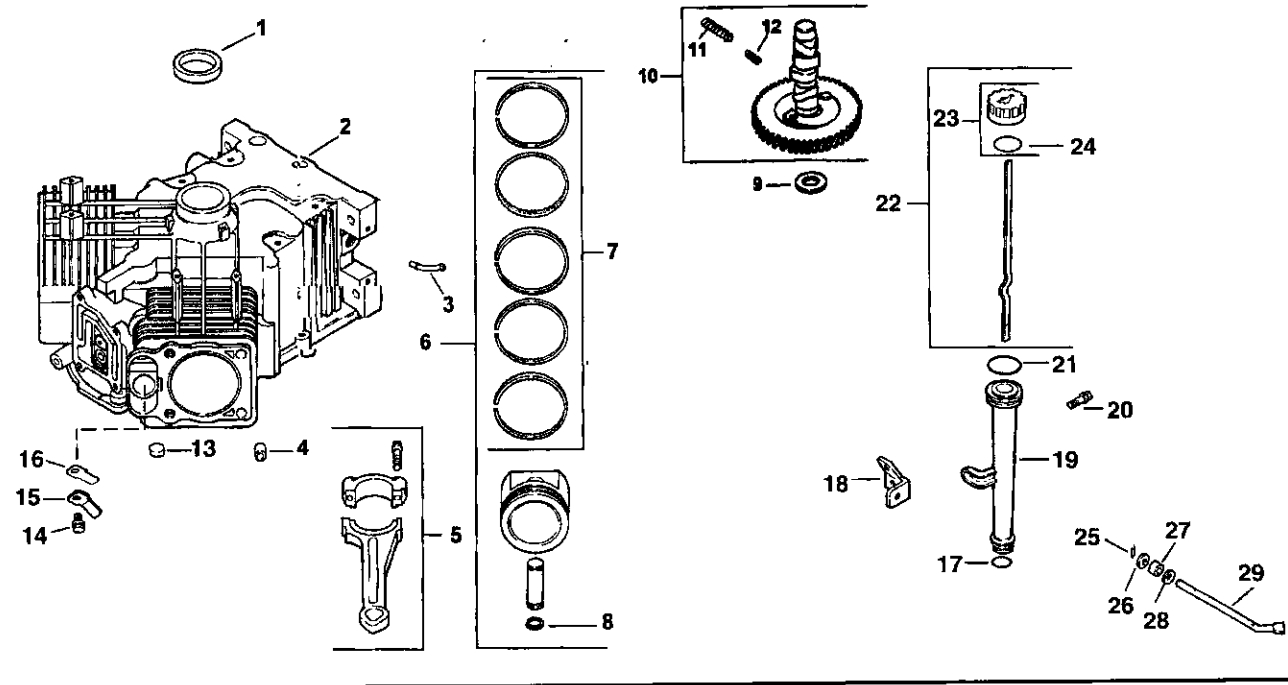

REPAIR PARTS

TRACTOR - - MODEL NUMBER 917.259090

KOHLER ENGINE - MODEL NUMBER CV20S, TYPE NUMBER 65563

HEAD/VALVE/BREATHER

KEY PART NO.	NO.	DESCRIPTION
1	24-033-03-S	Kit, breather cover w/gasket (Includes 2,3)
2	24-041-23-S	Gasket, breather
3	24-096-59-S	Cover, breather
4	M-645020	Screw, hex. flange M6x1.0x20 (4)
6	25-351-01-S	Lifter, valve (4)
7	24-755-66-S	Kit, valve train (Includes 8,11,12)
8	24-411-05-S	Rod, push (4)
9	24-041-08-S	Gasket, cylinder head (2)
10	24-318-12-S	Head assembly, #2 cylinder
11	25-186-01-S	Arm, rocker (4)
12	24-599-01-S	Pivot, rocker arm (4)
13	M640034-S	Screw, hex. flange M6x1.0x34 (4)
14	12-086-16-S	Screw, hex. flange M10x1.5x90 (8)
15	24-755-74-S	Kit, valve cover - plain (Includes 16,17)
16	24-153-16-S	O-Ring
17	24-086-32-S	Screw, shoulder (4)
18	24-445-01-S	Strap, lifting
19	24-016-01-S	Valve, exhaust (Std.) (2)
	24-016-02-S	Valve, exhaust (.25) (2)
20	24-017-01-S	Valve, intake (Std.) (2)
	24-017-02-S	Valve, intake (.25) (2)
21	24-032-05-S	Seal, valve stem (2)
22	235011-S	Retainer, spring (4)
23	24-089-02-S	Spring, valve (4)
24	12-173-01-S	Cap, valve spring (4)
25	12-755-03-S	Kit, retainer (4)
26	24-318-11-S	Head assembly, #1 cylinder
27	24-755-76-S	Kit, valve cover - breather (Incl. 16,17,28)
28	25-313-02-S	Grommet, rubber
29	24-755-57-S	Kit, breather separator (Includes 28,30-33)
30	M-545016-S	Screw, hex. flange M5x0.8x16 (2)
31	24-445-02-S	Strap, breather
32	24-126-44-S	Bracket, breather separator
33	24-112-12-S	Spacer
34	24-294-06-S	Fitting
35	24-326-13-S	Hose, breather
36	24-326-14-S	Hose, breather
37	X-426-9-S	Clamp, hose (2)

CRANKCASE

KEY PART NO.	NO.	DESCRIPTION
1	24-032-01-S	Seal, oil front
2		Crankcase (USE: Miniblock 24 782 05)
3	24-294-13-S	Fitting
4	12-380-17-S	Pin, dowel locating (6)
5	24-067-13-S	Connecting Rod (Std.) (2)
	24-067-14-S	Connecting Rod (.25) (2)
6	24-874-01-S	Piston w/Ring Set (Std.) (2) (Includes 7,8)
	24-874-02-S	Piston w/Ring Set (.25) (2)
	24-874-03-S	Piston w/Ring Set (.50) (2)
	24-874-14-S	Piston w/ring set (.08)
7.	24-108-01-S	Ring Set (Std.) (2)
	24-108-02-S	Ring Set (.25) (2)
	24-108-03-S	Ring Set (.50) (2)
8	24-018-01-S	Retainer, piston pin (4)
9	12-422-09-S	Shim, camshaft (A.R.)
	12-422-13-S	Shim, camshaft (A.R.)
	12-422-07-S	Shim, camshaft (A.R.)
	12-422-08-S	Shim, camshaft (A.R.)
	12-422-10-S	Shim, camshaft
	12-422-11-S	Shim, camshaft (A.R.)
	12-422-12-S	Shim, camshaft (A.R.)
10	24-010-06-S	Camshaft (Includes 11,12)
11	24-089-35-S	Spring acr (Heavy)
12	24-089-34-S	Spring acr (light)
13	52-139-09-S	Plug, cup
14	M-545010-S	Screw, hex. flange M5x0.8x10 (2)
15	24-018-04-S	Retainer, reed (2)
16	24-402-05-S	Reed, breather (2)
17	12-153-01-S	O-Ring, lower oil fill tube
18	24-126-19-S	Bracket, oil fill tube
19	12-123-04-S	Tube, oil fill
20	M-545016-S	Screw, hex. flange M5x0.8x16
21	12-153-02-S	O-Ring, upper oil fill tube
22	24-038-04-S	Dipstick assembly (Includes 22,23)
23	25-755-13-S	Kit, oil fill cap (Includes 23)
24	12-153-03-S	O-Ring, dipstick
25	12-380-04-S	Pin, hitch
26	M-631005-S	Washer, plain 6 mm
27	12-032-01	Seal, governor cross shaft
28	X-25-102	Washer, plain 1/4"
29	24-144-01-S-	Shaft, governor cross

REPAIR PARTS

TRACTOR - - MODEL NUMBER 917.259090

KOHLER ENGINE - MODEL NUMBER CV20S, TYPE NUMBER 65563

IGNITION/ELECTRICAL

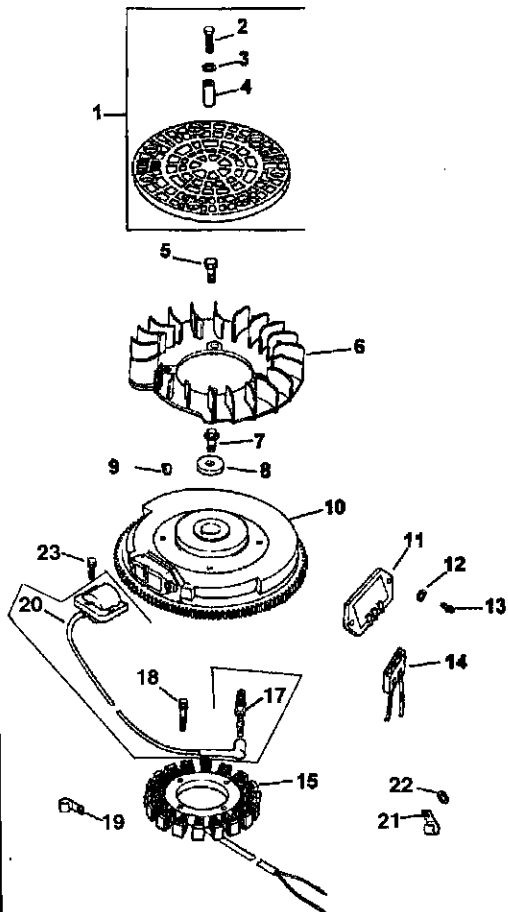

BLOWER HOUSING AND BAFFLES

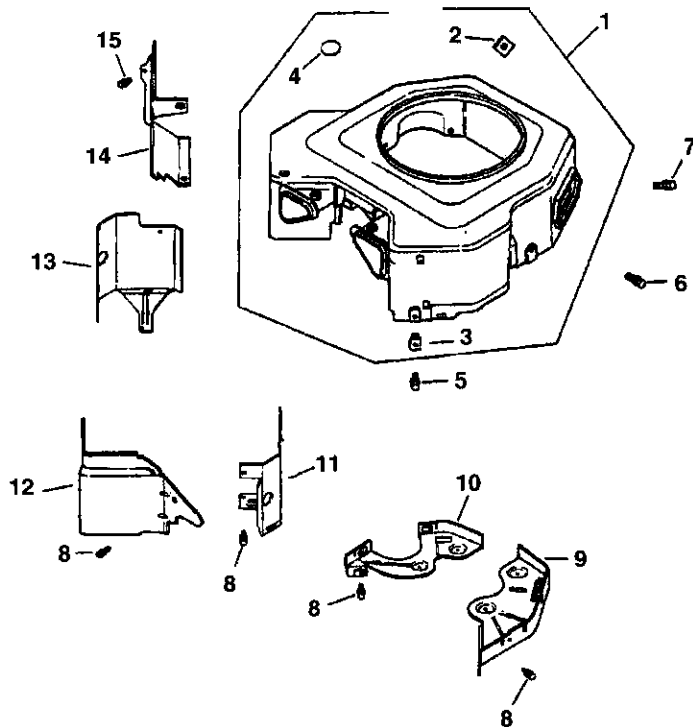

AIR INTAKE

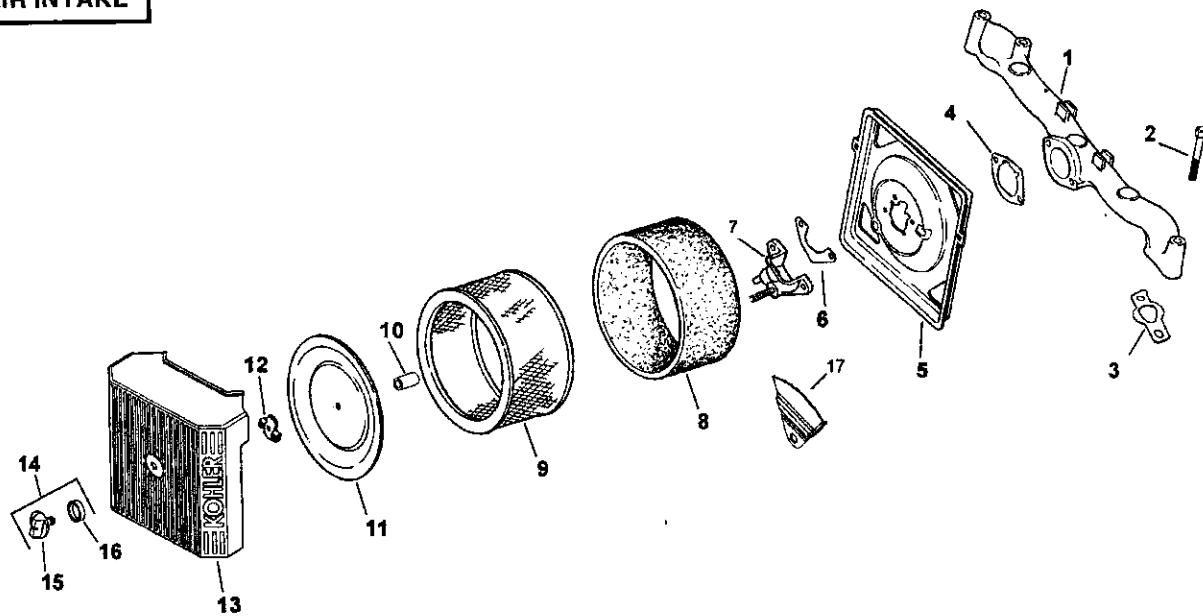

REPAIR PARTS

TRACTOR - - MODEL NUMBER 917.259090

KOHLER ENGINE - MODEL NUMBER CV20S, TYPE NUMBER 65563

IGNITION/CHARGING

KEY PART

NO.	NO.	DESCRIPTION
1	54-755-15-S	Kit, grass screen (Includes 2-4, and 24 113 18)
2	M-403025-S	Screw, hex. cap M4x0.7x25 (4)
3	X-25-92-S	Washer, plain 5/16" (4)
4	24-112-04-S	Spacer, grass screen (4)
5	25-086-47-S	Bolt, shoulder (4)
6	24-157-03-S	Fan
7	12-086-14-S	Screw, hex. flange M10x1.5x46
8	12-468-03-S	Washer, plain 3/8".
9	X-42-15-S	- Key
10	24-025-04-S	Flywheel
11	25-403-03-S	Rectifier-regulator
12	X-25-92-S	Washer, plain 3/16" (2)
13	24-086-18-S	Screw, phillips hd. 11-16x7/8 (2)
14	236602-S	Connector (3 contact)
15	54-755-09-S	Kit, 15 amp stator (Includes 24 126 71)
16	24-707-02-S	Module Kit, Ignition (Includes 17,20)
17	28-132-02-S	Spark Plug (2)
18	M-548025-S	Screw, hex. cap M5x0.8x25 (2)
19	235173-S	Clip, cable
20	24-584-14-S	Module, ignition (2)
21	48-154-02-S	Clip, cable
22	X-25-63-S	Washer, plain 1/4"
23	M-545020-S	Screw, hex. flange M5x0.8x20 (4)

NOT ILLUSTRATED

--	24-126-71-S	Bracket, stator wire
--	X-22-11-S	Washer, lock 1/4"
--	24-176-79-S	Harness, wiring Lead, black (rect.-reg. 5" - 12 gauge insulated grip barrel eyelets)
--	24-518-12-S	Decal, grass screen
--	24-113-18-S	Decal, grass screen
--	25-454-03-S	Tie, wire (3)

BLOWER HOUSING & BAFFLES

KEY PART

NO.	NO.	DESCRIPTION
1	24-027-20-S	Housing, blower (Incl. 2-4)
2	24-100-01-S	Nut plastic (3)
3	25-139-16-S	Plug, button 9/16
4	24-100-02-S	Nut, plastic (2)
5	M-545020-S	Screw, hex. flange M5x0.8x20 (4)
6	M-545016-S	Screw, hex. flange M5x0.8x16 (3)
7	M-551016-S	Screw, hex. flange M5x0.8x16
8	M-645016-S	Screw, hex. flange M6x1.0x16 (6)
9	24-146-16-S	Plate, backing - # 2 side
10	24-146-20-S	Plate, backing - # 1 side
11	24-063-40-S	Baffle, cylinder barrel-# 2 side
12	24-063-14-S	Baffle, valley - #2 side
13	24-063-44-S	Baffle, cylinder barrel-# 1 side
14	24-063-23-S	Baffle, valley - #1 side
15	M-545010-S	Screw, hex. flange M5x0.8x10 (2)

NOT ILLUSTRATED

AIR INTAKE/FILTRATION

KEY PART

NO.	NO.	DESCRIPTION
1	24-164-06-S	Manifold, intake
2	M-651055-S	Screw, hex. flange M6x1.0x55 (4)
3	24-041-01-S	Gasket, intake manifold (2)
4	24-041-14-S	Gasket, air cleaner base
5	24-094-19-S	Base, air cleaner
6	24-041-13-S	Gasket, fuel spitback cup
7	24-109-10-S	Cup, fuel spitback
8	24-083-02-S	Precleaner, element
9	47-083-03-S	Element, air cleaner
10	24-032-03-S	Seal, breather
11	24-096-01-S	Cover, inner air cleaner
12	12-100-01-S	Wing Nut
13	24-096-67-S	Cover, air cleaner
14	54-755-01-S	Kit, knob with seal (Includes 15 & 16)
15	24-153-20-S	O-Ring
16	25-341-03-S	Knob, cover
17	24-063-51-S	Baffle, fuel spit-back

REPAIR PARTS

TRACTOR - - MODEL NUMBER 917.259090

KOHLER ENGINE - MODEL NUMBER CV20S, TYPE NUMBER 65563

STARTING SYSTEM

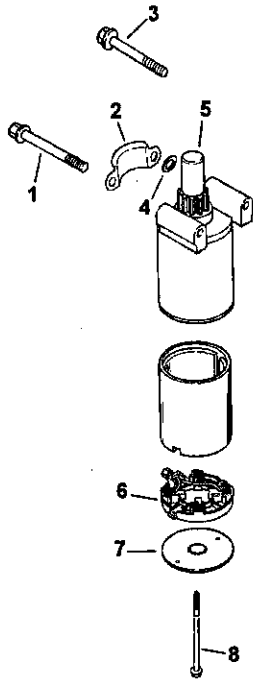

ENGINE CONTROLS

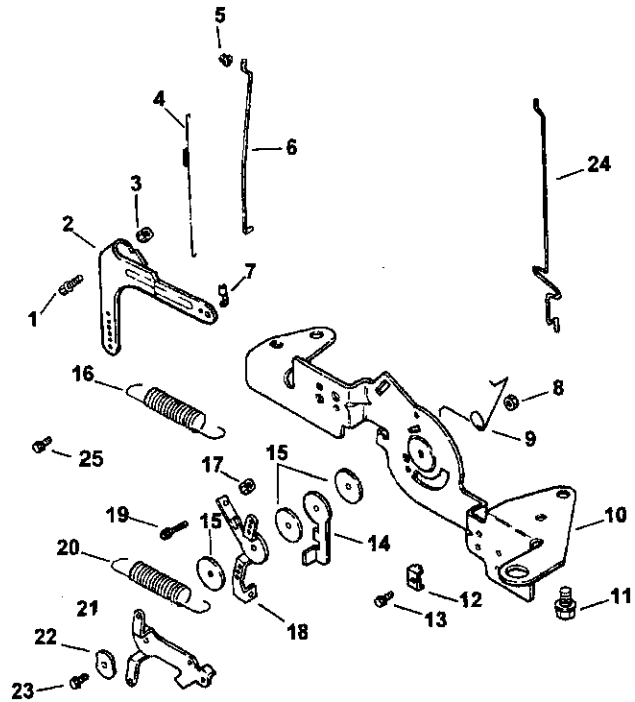

OIL PAN / LUBRICATION

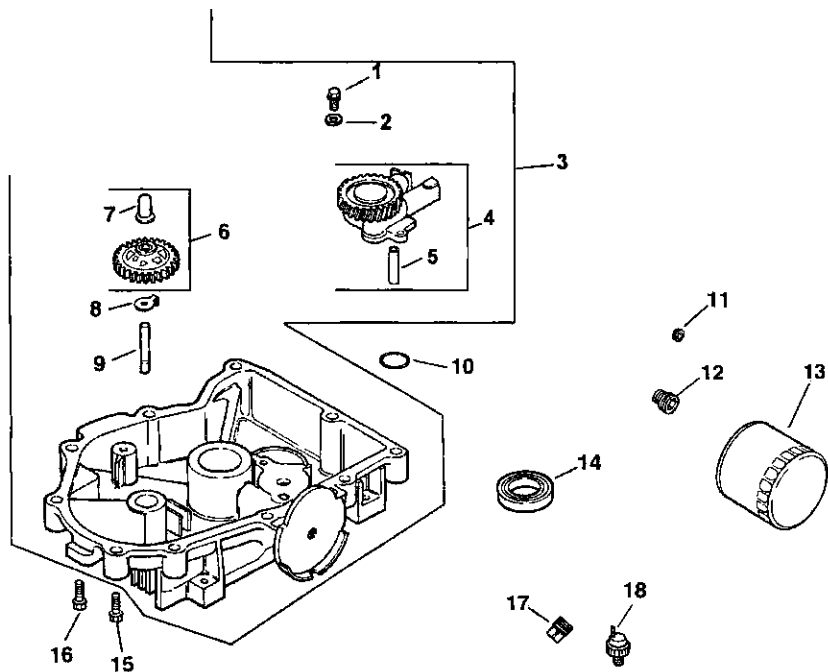
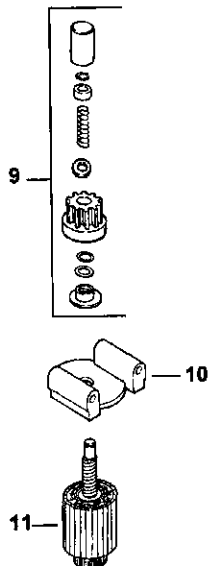

REPAIR PARTS

TRACTOR - - MODEL NUMBER 917.259090

KOHLER ENGINE - MODEL NUMBER CV20S, TYPE NUMBER 65563

STARTING SYSTEM

KEY PART NO.	NO.	DESCRIPTION
1	M-839070-S	Screw, hex. flange M8x1.25x70
2	24-096-05-S	Cover, pinion
3	M-839080-S	Screw, hex. flange M8x1.25x80
4	12-468-01-S	Washer, plain 11/32"
5	25-098-07-S	Starter, (Includes 6-11)
6	12-221-01-S	Kit, brush
7	12-227-18-S	Cap
8	12-211-01-S	Bolt, thru (2)
9	12-755-54-S	Kit, drive
10	12-227-06-S	Cap, drive end
11	12-170-05-S	Armature

OIL PAN/LUBRICATION

KEY PART NO.	NO.	DESCRIPTION
1	M-645025-S	Screw, hex. flange M6x1.0x25 (2)
2	M-631005-S	Washer, plain 6 mm (2)
3	24-199-07-S	Pan, oil assembly (Includes 1,2, & 4-9)
4	24-393-08-S	Oil pump assembly (Includes 5)
5	24-123-05-S	Tube, oil pickup
6	24-043-12-S	Kit, governor gear w/pin (Includes 8)
7	12-380-01-S	Pin, governor regulating
8	52-448-02-S	Tab, locking
9	12-144-02-S	Shaft, governor gear
10	24-153-08-S	O-Ring
11	X-75-32-S	Plug, hex. ctsk. 3/8"
12	24-136-01-S	Nipple, oil filter
13	12-050-01-S	Filter, oil
14	52-032-08-S	Seal, oil (PTO end)
15	24-086-17-S	Screw, hex. flange M8x1.25x45
16	24-086-16-S	Screw, hex. flange M8x1.25x45 (9)
17	X-75-10-S	Plug, sq. hd. solid 3/8" N.P.T.F.
18	25-099-24-S	Switch, pressure

ENGINE CONTROLS

KEY PART NO.	NO.	DESCRIPTION
1	SM-642025-S	Screw, hex. flange M6x1.0x25
2	24-090-14-S	Lever, governor
3	M-641060-S	Nut, hex. flange M6x1.0
4	24-089-01-S	Spring, linkage
5	25-158-08-S	Bushing, linkage retaining
6	24-079-04-S	Linkage, throttle
7	25-158-11-S	Bushing, throttle linkage
8	M-547050-S	Nut, hex. lock M5x0.8
9	24-089-03-S	Spring, choke return
10	24-126-56-S	Bracket, control
11	M-645016-S	Screw, hex. flange M6x1.0x16 (4)
12	12-237-01-S	Clamp, cable (2)
13	M-545016-S	Screw, hex. flange M5x0.8x16 (1)
14	24-090-07-S	Lever, throttle actuator
15	24-468-01-S	Washer, plain 5.5 mm (3)
16	24-089-18-S	Spring, governor
17	M-446030-S	Nut, hex M4x0.7
18	24-090-13-S	Lever, throttle control
19	M-545020-S	Screw, hex. flange M5x0.8x20
20	24-089-51-S	Spring, throttle limiter
21	24-090-05-S	Lever, choke
22	41-468-03-S	Washer, spring 1/4"
23	M-403025-S	Screw, hex. cap M4x0.7x25
24	24-079-05-S	Linkage, choke
25	24-086-43-S	Screw, thread forming (2)

REPAIR PARTS

TRACTOR - - MODEL NUMBER 917.259090

KOHLER ENGINE - MODEL NUMBER CV20S, TYPE NUMBER 65563

CRANKSHAFT

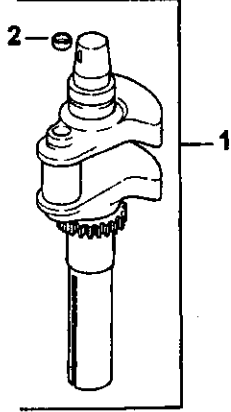

EXHAUST

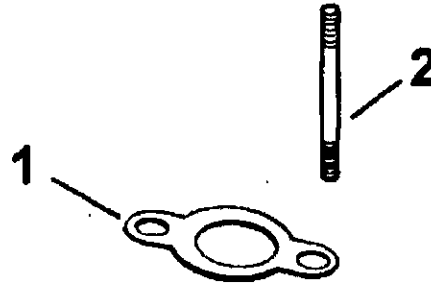

FUEL SYSTEM

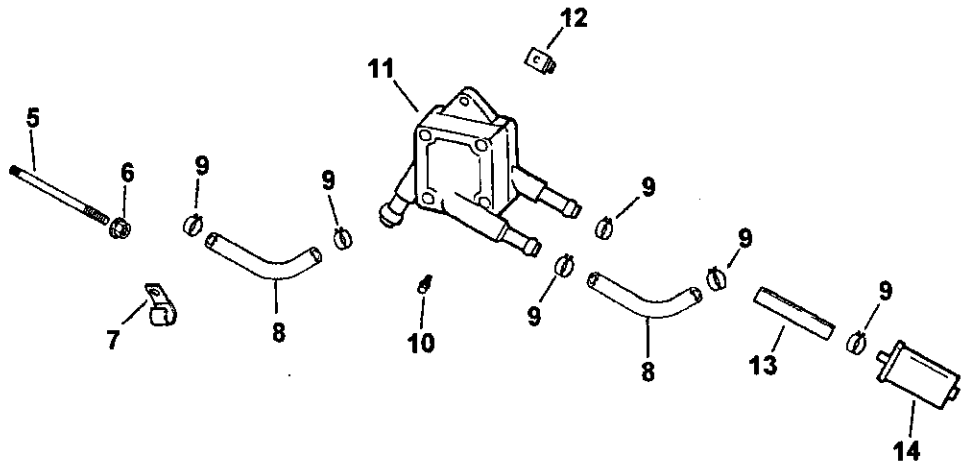
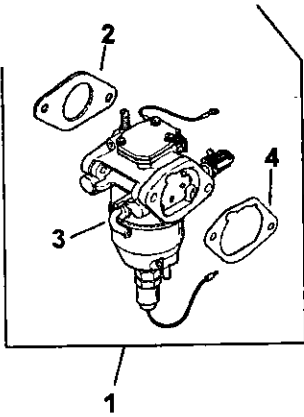

REPAIR PARTS

TRACTOR - - MODEL NUMBER 917.259090

KOHLER ENGINE - MODEL NUMBER CV20S, TYPE NUMBER 65563

CRANKSHAFT

KEY PART

NO.	NO.	DESCRIPTION
1	24-014-72-S	Crankshaft (Includes 2)
2	52-139-09-S	Plug, cup

EXHAUST

KEY PART

NO.	NO.	DESCRIPTION
1	24-041-02-S	Gasket, exhaust (2)
2	25-072-04-S	Stud, M8x1.25x33 (4)

NOT ILLUSTRATED

--	24-522-16	Short Block
--	24-782-05	Miniblock
--	24-755-03-S	Gasket Set

FUEL SYSTEM

KEY PART

NO.	NO.	DESCRIPTION
1	24-853-25-S	Kit, carburetor w/gaskets (Includes 2-4)
2	24-041-15-S	Gasket, carburetor
3	24-053-25-S	Carburetor assembly (For information only not available separately) (Includes 24 757 18, 24-757-19, 24-757-20, 24-757-22)
4	24-041-14-S	Gasket, air cleaner base
5	M-629095-S	Stud, M6x1.0x95 (2)
6	M-641060-S	Nut, hex. flange M6x1.0 (2)
7	47-154-01-S	Clip, cable
8	24-353-03-S	Line, fuel 10-5/8" (2)
9	X-426-9-S	Clamp, hose (6)
10	24-086-12-S	Screw, hex. cap. M6x1.7x18 (2)
11	24-393-16-S	Pump, fuel - pulse
12	24-100-01-S	Nut, plastic (2)
13	15-353-04-S	Line, fuel 11-1/2"
14	24-050-03-S	Filter, fuel

NOT ILLUSTRATED

--	24-757-18-S	Kit, overhaul w/gaskets
--	24-757-19-S	Kit, choke repair w/gaskets
--	24-757-20-S	Kit, gasket
--	24-757-22-S	Kit, solenoid replacement w/gaskets

SERVICE NOTES
