

REPAIR PARTS MANUAL
MODEL NO. 917.259130
Lawn Tractor

CRAFTSMAN®

HOW TO USE THIS MANUAL

This manual is designed to provide the customer with a means to identify the parts on his/her tractor when ordering repair parts. The illustrations may or may not represent the actual assemblies; therefore, it is not recommended to use this manual as a guide to assemble or disassemble the tractor. Some hardware and parts are drawn larger in order to more readily identify them.

Each tractor has its own model number.

The model number for your tractor can be found on the fender under the seat.

When ordering parts, always give the following information:

- Product - "Tractor"
- Model Number - "259130"
- Part Number
- Part Description

TABLE OF CONTENTS

SCHEMATIC	3
ELECTRICAL.....	4-5
CHASSIS	6-7
DRIVE	8-9
STEERING WHEEL	10-11
ENGINE	12-13
SEAT	14
DECALS	15
MOWER LIFT LEVER	16-17
MOWER DECK	18-19
TRANSAXLE	20-21

TRACTOR - - MODEL NUMBER 917.259130

SCHEMATIC

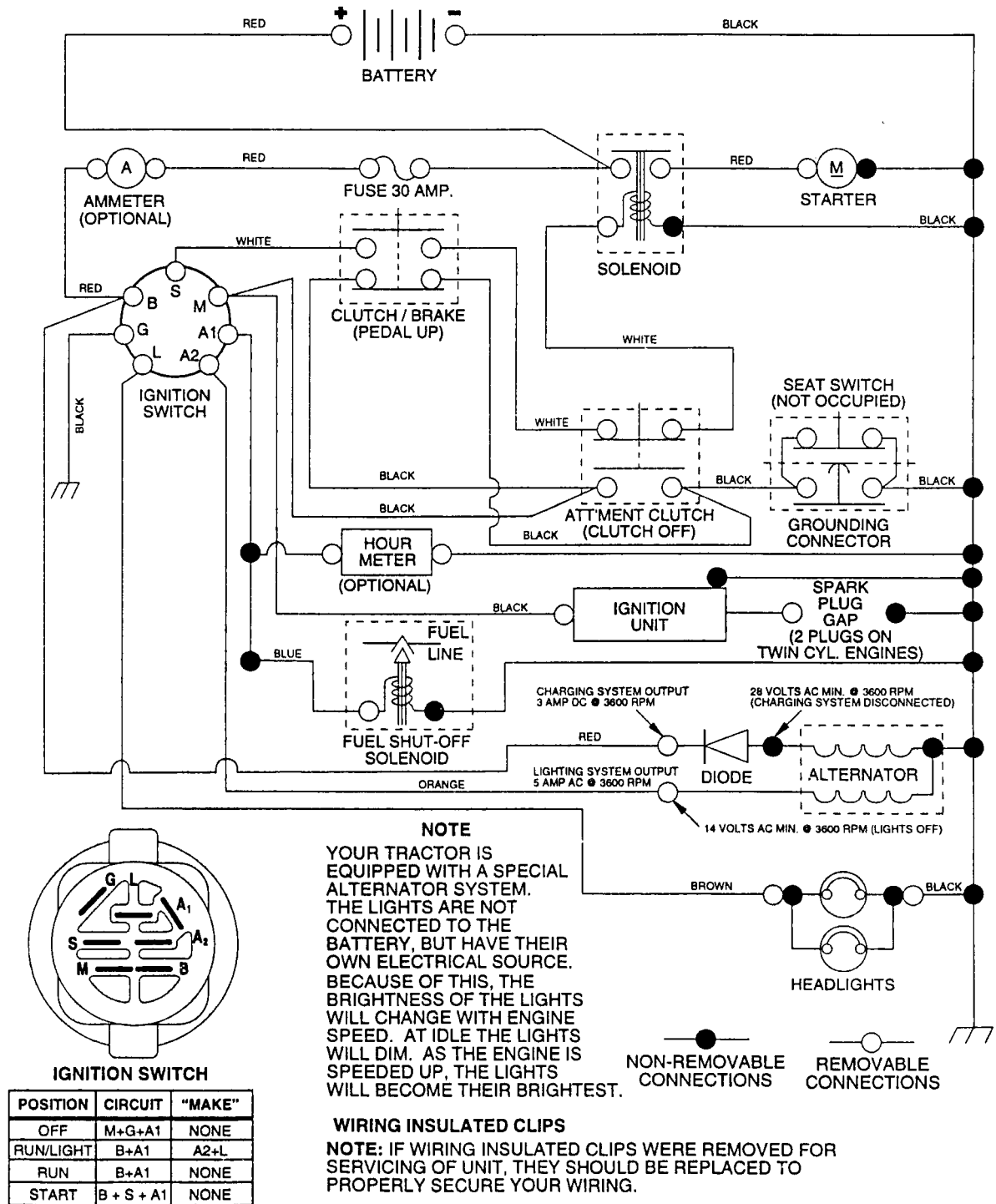

REPAIR PARTS

TRACTOR - - MODEL NUMBER 917.259130

ELECTRICAL

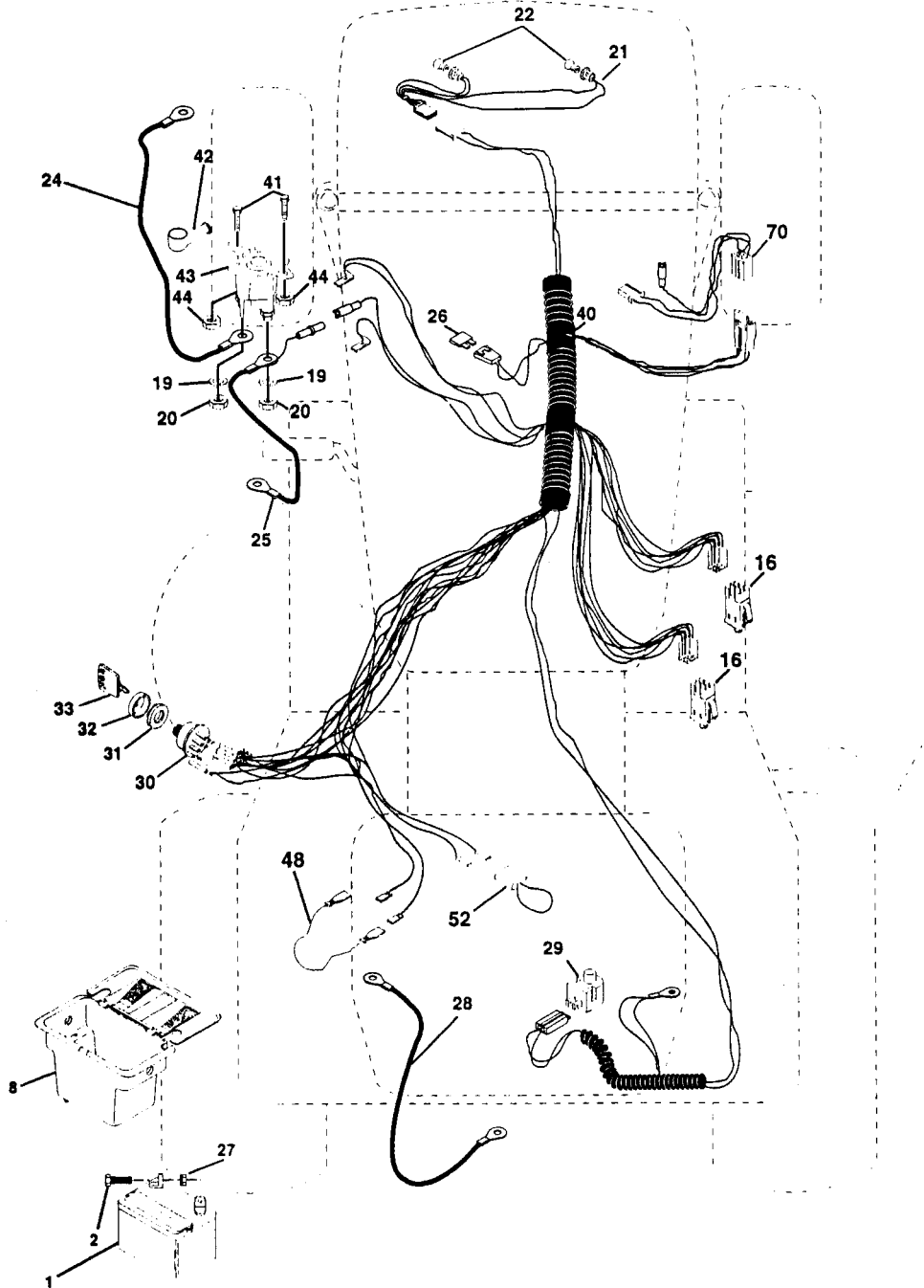

TRACTOR - - MODEL NUMBER 917.259130

ELECTRICAL

KEY NO.	PART NO.	DESCRIPTION
1	144925	Battery 12 Volt 25 Amp
2	74760412	Bolt, Hex Head 1/4-20 unc x 3/4
8	156417	Case, Battery Mech Hinge
16	153664	Switch, Interlock Push-In
19	STD551125	Washer, Lock
20	73350400	Nut, Hex, Jam 1/4-20 UNC
21	166181	Harness, Light Socket (Includes 4152J)
22	4152J	Bulb, Light
24	4799J	Cable, Battery, 6 Gauge, Red, 11"
25	146147	Cable, Battery, 6 Gauge, Red, W/16 Wire
26	166180	Fuse
27	73510400	Nut Keps Hex 1/4-20 UNC
28	4207J	Cable, Ground, 6 Gauge, Black, 12"
29	121305X	Switch, Plunger
30	163968	Switch, Ignition
33	140403	Key, Ignition
40	166151	Harness, Ignition
41	71110408	Bolt, Hex Head, Fin. 1/4-20 x 1/2
42	131563	Cover, Terminal, Red
43	145673	Solenoid
44	73640400	Nut Keps Blk Hex 1/4-20 UNC
48	140844	Adaptor Ammeter Rectangular
52	141940	Protection Wire Loop
70	166658	Harness Engine B&S

NOTE: All component dimensions give in U.S. inches
1 inch = 25.4 mm

TRACTOR -- MODEL NUMBER 917.259130
CHASSIS AND ENCLOSURES

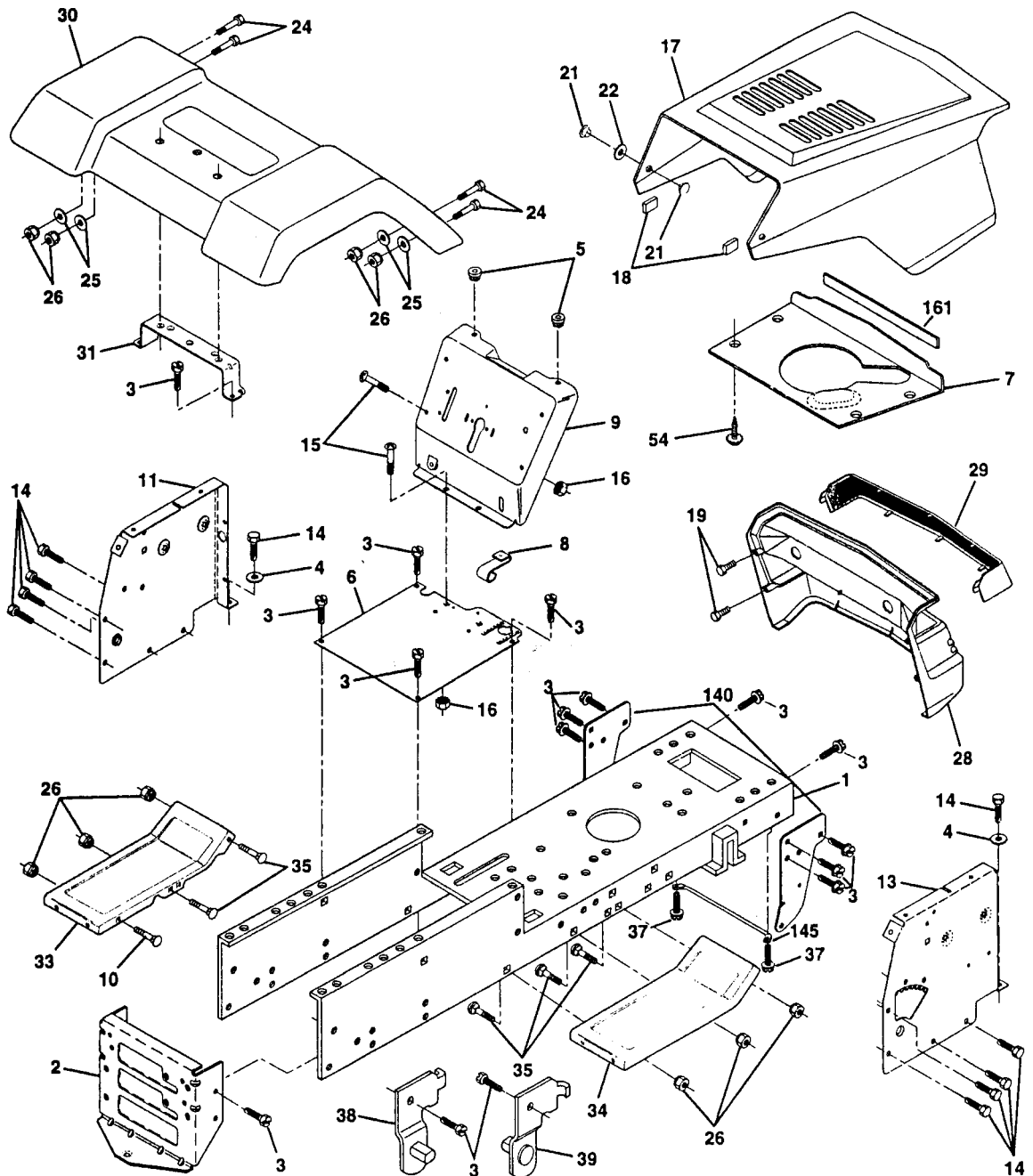

TRACTOR - - MODEL NUMBER 917.259130
CHASSIS AND ENCLOSURES

KEY NO.	PART NO.	DESCRIPTION
1	165480	Chassis Asm. LT STMP
2	140356	Drawbar Stretch
3	17490612	Screw Thdrol 3/8-16 x 3/4 Ty-tt
4	STD551025	Washer 13/32 X 3/4 X 16 Ga
5	155272	Bumper Hood/Dash
6	155924X011	Saddle Slkscr Flt LT 6SP Peerless
7	126842X	Shield Ht. Hood Lt
8	155138	Clip Retainer Slide-On
9	166318X010	Dash Slkscr 1-pc
10	STD533710	Bolt Rdhd Sqnk 3/8-16unc X 1
11	155927	Panel Dash LH
13	155934X010	Panel Slkscr Dash RH
14	17490608	Screw Thdrol 3/8-16 x 1/2 Ty-tt
15	74180512	Screw Mach TRHD 5/16-18 unc x 3/4
16	STD541431	Nut Keps 5/16-18 Unc
17	154988X558	Hood Asm
18	126938X	Bumper Hood
19	164863	Screw Hwhd Hi-Lo #13-16 x 3/4
21	122933X	Rivet Ratchet Nylon
22	124479X	Washer Nylon Blk 28 x 75 x 19
24	STD523710	Bolt Fin Hex 3/8-16 unc x 1 Gr. 5
25	19131312	Washer 13/32 X 13/16 x 12 Ga
26	STD541437	Nut Hex Lock W/Ins. 3/8-16 Unc
28	140135X428	Grille Black
29	124029X599	Lens Headlight Bar Clear
30	157584X558	Fender Pnt LT W/o Shift
31	136619	Bracket Fender Repl 109873x
33	105476X558	Footrest Pnt Lh
34	105475X558	Footrest Pnt Rh
35	STD533707	Bolt Rdhd Sht Sqnk 3/8-16 x 3/4
37	17490508	Screw Thdrol 5/16-18 x 1/2
38	139886	Bracket Asm Pvt LH MWR Rear
39	139887	Bracket Asm Pvt RH MWR Rear
54	161464	Screw
140	158418	Bracket Suspension Front
145	156524	Rod Pivot Chassis/Hood
161	161547	Extrusion Hood
--	5479J	Plug Button Blk 359 Dia Choke

NOTE: All component dimensions give in U.S. inches
1 inch = 25.4 mm

TRACTOR - - MODEL NUMBER 917.259130

GROUND DRIVE

KEY NO.	PART NO.	DESCRIPTION	KEY NO.	PART NO.	DESCRIPTION
1	-----	Transaxle (See Breakdown) Peerless 205-544C	42	19131312	Washer 13/32 x 13/16 x 12 Ga
2	146682	Spring Return Brake T/a Zinc	47	127783	Pulley Idler V Groove Plastic
3	123666X	Pulley Transaxle 18/20" tires	48	154407	Bellcrank Asm. Clutch
4	12000028	Ring Retainer # 5100-62	49	123205X	Retainer Belt Style Spring
5	121520X	Strap Torque 30 Degrees	50	STD523715	Bolt Hex Hd 3/8-16unc x 1-1/2
6	17490512	Screw Thdrol 5/16-18 x 3/4 TYT	51	STD541437	Nut Crownlock 3/8-16 UNC
7	162240	Bracket Saddle Shift T/a	52	STD541431	Nut Crown Lock 5/16-18
8	131679	Rod Shf Sdl LY/YT Str Blk Zinc	53	105710X	Link Clutch 7 66
10	STD561210	Pin Cotter 1/8 x 1 Cad	55	105709X	Spring Return Clutch 6 75
11	105701X	Washer Plate Shf 388 Sq Hole	56	STD523712	Bolt Fin Hex 3/8-16 unc x 1-1/4
12	19151216	Washer 15/32 x 3/4 x 16ga	57	130801	V-Belt Gd Drive 95 00
13	74550412	Bolt 1/4-28unf Gr8 W/Patch	58	127274X	Keeper Belt RH
14	STD551125	Washer Lock Hvy Helical 1/4	59	140312	Keeper Belt Centerspan
18	STD523710	Bolt Fin Hex 3/8-16 UNC x 1 Gr. 5	61	17490612	Screw Thdrol 3/8-16 x 3/4 Ty-tt
19	STD541437	Nut Lock Hex W/Ins. 3/8-16 Unc	62	8883R	Cover Pedal Blk Round
21	106933X	Knob Rd 1/2-13 Plstc Thds Blk	63	140186	Pulley Eng Cl Mech 38deg LT/YT
22	130804	Rod Brake Blk Zinc 26 840	64	71170764	Bolt Hex 7/16-20 x 4 Gr 5
24	STD541237	Nut Hex Jam 3/8-16 Unc	65	STD551143	Washer Lock Hvy Hlcl Spr 7/16
25	106888X	Spring Rod Brake 2 00 Zinc	66	154778	Keeper Belt Engine Fool Proof
26	STD551037	Washer 13/32 x 13/16 x 16 Ga	70	134683	Guide Belt Mower Drive RH
27	STD561210	Pin Cotter 1/8 x 3/4 Cad	72	19132012	Washer 13/32 x 1-1/4 x 12 Ga
28	145204	Rod Brake Parking Lt/Yt	74	137057	Spacer Axle
29	124236X	Cap Brake Parking Red	75	121749X	Washer 25/32 x 1 1/4 x 16 Ga
30	130807	Bracket Mtg Transaxle	76	STD581075	E-ring #5133-75
31	127275X	Keeper Belt LH	77	123583X	Key Square 2 0 x 1845/ 1865
32	STD523107	Bolt Hex Hd 5/16-18unc x 3/4	78	121748X	Washer 25/32 x 1-5/8 x 16 Ga
34	155071	Shaft Asm Pedal Foot LT/STLT	79	2228M	Key Woodruff #9 3/16 x 3/4
35	120183X	Bearing Nylon Blk 629 Id	96	4497H	Retainer Spring 1"
36	STD551062	Washer 21/32 x 1 x 16 Ga	112	19091210	Washer 9/32 x 3/4 x 10 Ga
37	1572H	Pin Roll 3/16 x 1"	113	127285X	Strap Torque LH LT
38	131494	Pulley Idler Flat	116	72110610	Bolt Rdhd Sq Neck 3/8-16 x 1.25
39	STD523727	Bolt Fin Hex 3/8-16unc x 2-3/4	145	74490540	Bolt Hex Flghd 5/16-18 x Gr. 5
40	4470J	Spacer Split 395 x 59 Bzp	150	165850	Bushing Bellcrank GRD Drive
41	165838	Keeper Belt Idler	151	19133210	Washer 13/32 x 2 x 10 Ga.

NOTE: All component dimensions give in U.S. inches
1 inch = 25.4 mm

TRACTOR - - MODEL NUMBER 917.259130

STEERING ASSEMBLY

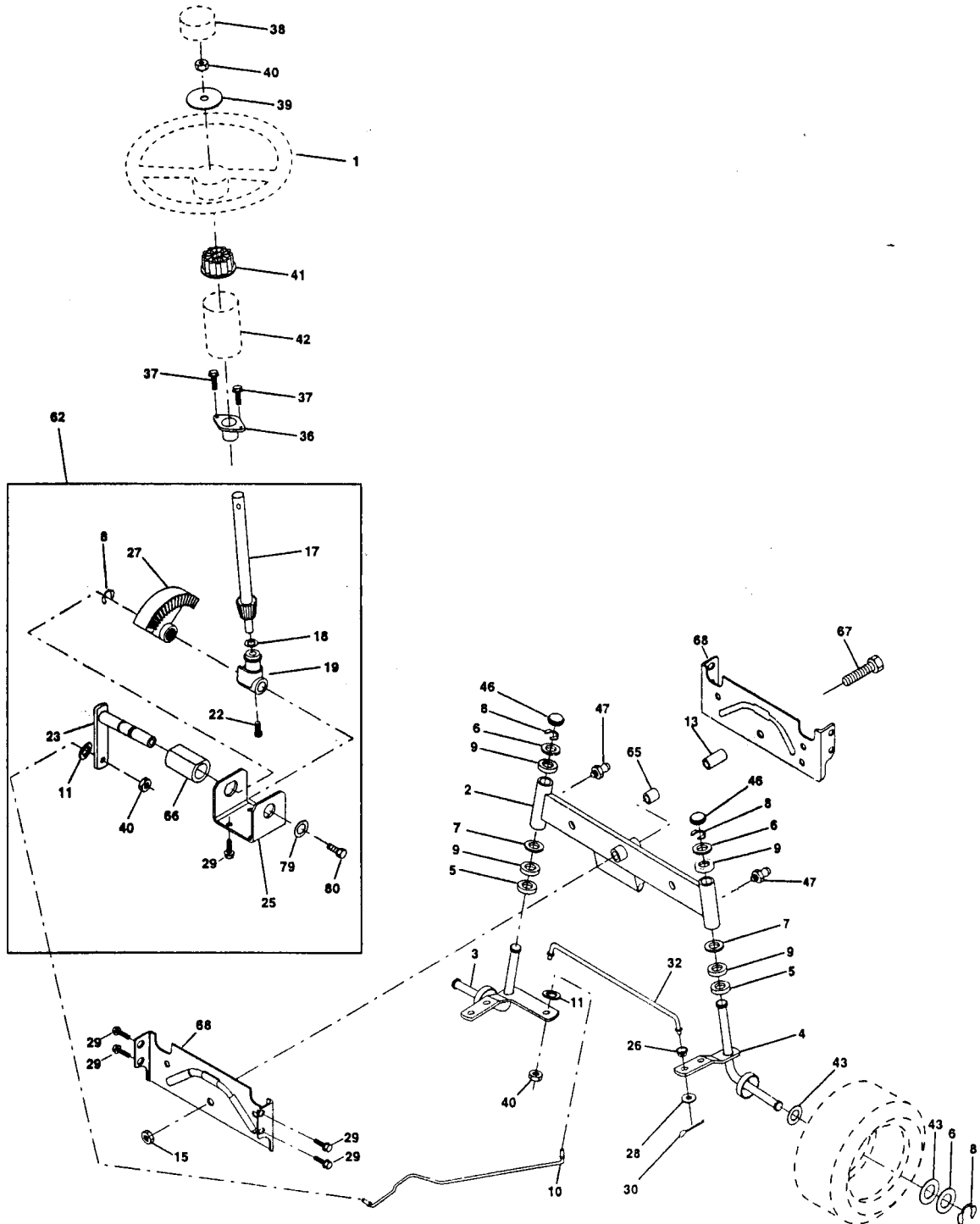

TRACTOR - - MODEL NUMBER 917.259130
STEERING ASSEMBLY

KEY NO.	PART NO.	DESCRIPTION
1	139768	Steering Wheel
2	154427	Axle Assembly STMP Dropped STL
3	156483	Spindle Assembly, L.H.
4	157473	Spindle Assembly, R.H.
5	6266H	Bearing, Race, Thrust, Hardened
6	121748X	Washer 25/32 x 1-5/8 x 16 Gauge
7	19272016	Washer 27/32 x 1-1/4 x 16 Gauge
8	12000029	Ring, Klip
9	3366R	Bearing, Steering Column
10	156438	Draglink Extended Stamped
11	STD551137	Washer, Lock
13	154779	Bearing Axle STLT/GT
15	73901000	Nut, Lock, Flange 5/8-11 UNC
17	156545	Shaft Assembly, Steering
18	57079	Washer, Thrust .515 x .750 x .033
19	160395	Support, Shaft
22	165857	Screw, Hex Wshhd
23	165851	Pittman Shaft Assembly
25	154406	Bracket, Steering
26	126847X	Bushing, Link, Drag
27	136874	Gear, Sector
28	19131416	Washer 13/32 x 7/8 x 16 Gauge
29	17490612	Screw, Thd., Roll. 3/8-16 x 3/4
30	STD561210	Pin
32	130465	Rod, Tie
36	155099	Bushing, Steering
37	152927	Screw
38	139769	Insert, Steering Wheel
39	19133808	Washer 13/32 x 2-3/8 x 8 Gauge
40	STD541537	Gripco Nut
41	104820X	Adaptor, Steering Wheel
42	124417X	Boot, Steering Shaft
43	121749X	Washer 25/32 x 1-1/4 x 16 Gauge
46	121232X	Cap, Spindle
47	6855M	Fitting, Grease
62	167903	Kit Steering Asm Service
65	154780	Spacer Axle
66	154404	Bearing Arm Pittman
67	74781044	Bolt, Fin Hex 5/8-11 UNC x 2-3/4
68	154429	Axle, Brace
79	19132012	Washer 13/32 x 1-1/4 x 12 Ga.
80	74950612	Bolt Hex Nylon 3/8-16 x 3/4

NOTE: All component dimensions given in U.S. inches
1 inch = 25.4 mm

TRACTOR -- MODEL NUMBER 917.259130

ENGINE

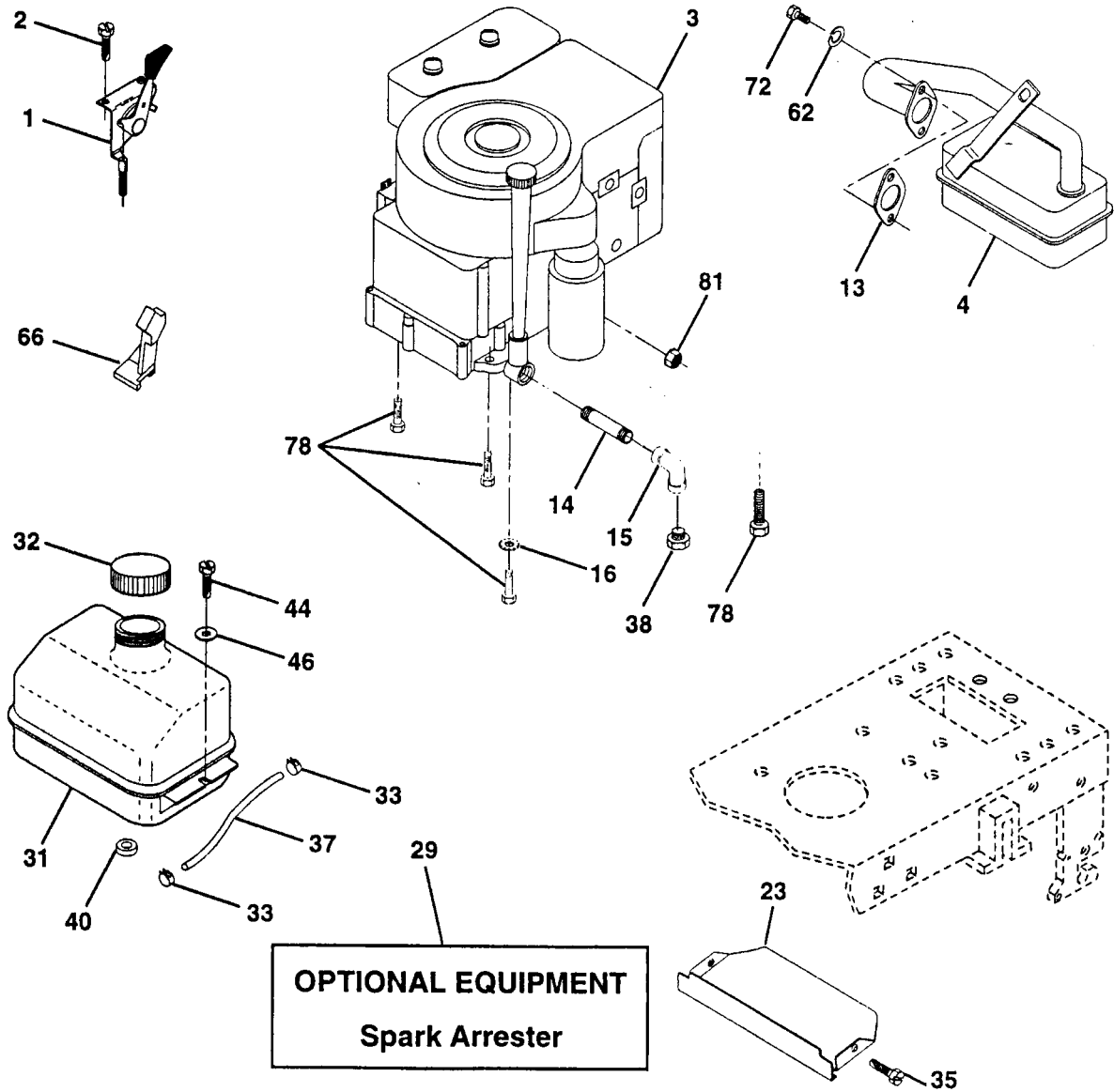

TRACTOR - - MODEL NUMBER 917.259130

ENGINE

KEY NO.	PART NO.	DESCRIPTION
1	162155	Control Th/ch RH Blk Pdl 15 10
2	17720410	Screw Hex Thd Cut 1/4-20x5/8 T
3	-----	Engine (See Breakdown) Briggs Model 28R707-1140-E1
4	137348	Muffler
13	165291	Gasket Eng 1 313 Id Tin Plated
14	13280324	Nipple Pipe 3/8 Npt x 3"
15	13200300	Elbow Std 90 Degree 3/8-18 Npt
16	STD551237	Washer Lock Ext Tooth 3/8
23	159880	Shield Browning
29	137180	Kit Spark Arrestor (Flat Scrm)
31	109202X	Tank Fuel Front 1 25
32	158990	Cap Asm Fuel W/sym Vented
33	123487X	Clamp Hose Blk
35	17490512	Screw Thdrol 5/16-18 x 3/4 TYT
37	137040	Line Fuel 20"
38	-----	Plug Oil Drain (Order From Engine Manufacturer)
40	124028X	Bushing Snap Nyl Blk Fuel Line
44	17490412	Screw Hexwsh Thdrol 1/4-20 x 3/4
46	19091416	Washer 9/32 x 7/8 x 16 ga
62	STD551131	Washer Lock Hvy Hlcl Spr 5/16
66	127951	Stop Throttle
72	71070512	Screw Hex Hd Cap 5/16-18 X 3/4
78	17490620	Screw Thdrol 3/8-16x1-1/4 TYTT
81	128861	Nut Flange 1/4-20 Starter Nut

NOTE: All component dimensions given in U.S. inches
1 inch = 25.4 mm

TRACTOR - - MODEL NUMBER 917.259130

SEAT ASSEMBLY

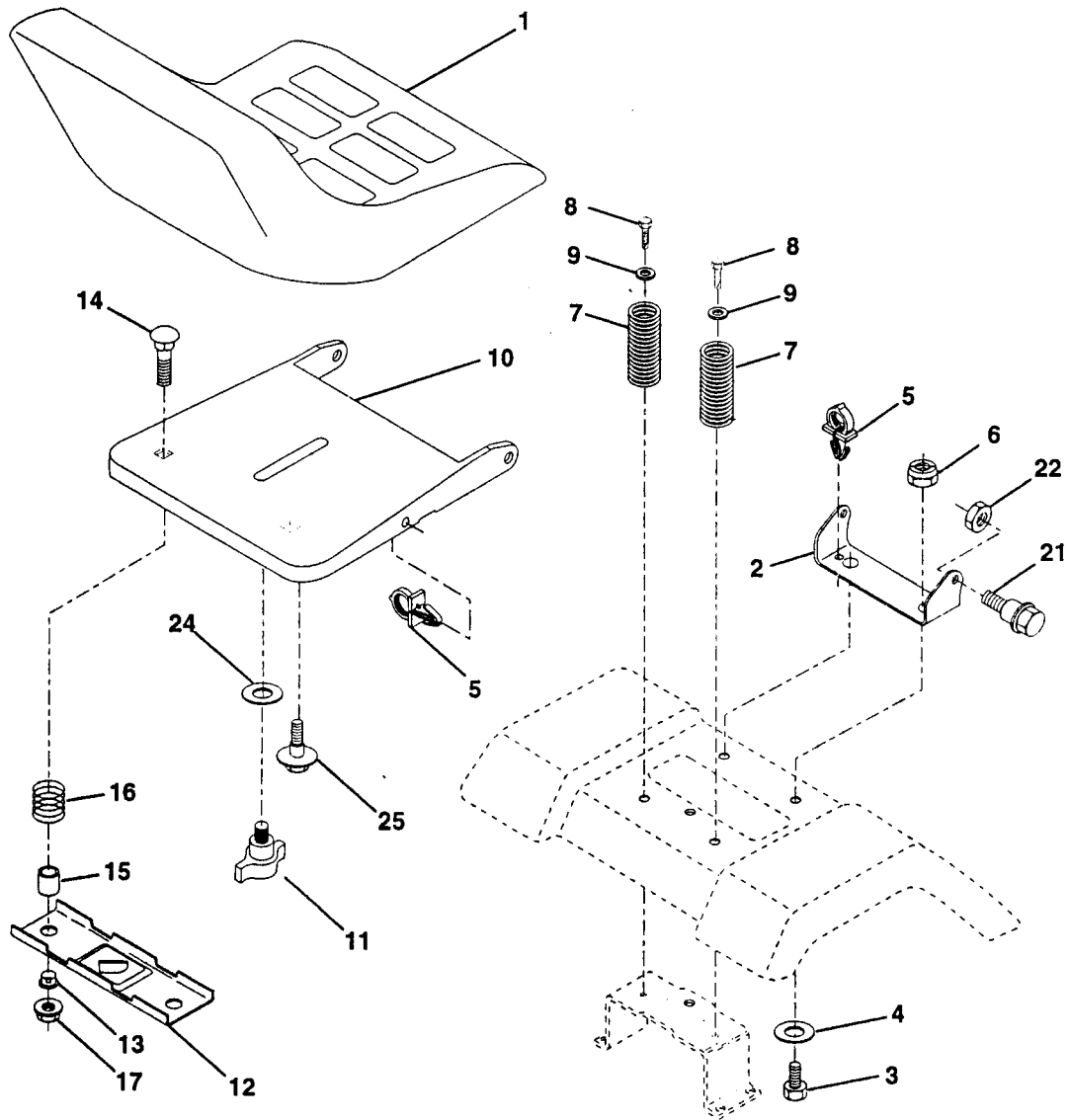

KEY NO.	PART NO.	DESCRIPTION	KEY NO.	PART NO.	DESCRIPTION
1	127426X	Seat	12	121246X	Bracket Mounting Switch
2	140551	Bracket Pvt St	13	121248X	Bushing Snap Blk Nyl 50 Id
3	STD523710	Bolt Fin Hex 3/8-16unc X 1	14	72050412	Bolt Rdhd Sht Nk 1/4-20x1-1/2
4	19131610	Washer Flat 13/32 X 1 X 10 Ga	15	134300	Spacer Split 28x 96 Yel Zinc
5	145006	Clip Push-In Hinged	16	121250X	Spring Cprsn 1 27 Blk Pnt
6	STD541437	Locknut Hex W/Wsh 3/8-16	17	123976X	Nut Lock 1/4 Lge Flg Gr 5 Zinc
7	124181X	Spring Seat Cprsn 2 250 Blk Zi	21	153236	Bolt Shld 5/16-18 Unc
8	17490616	Screw Thdrol 3/8-16 X 1 Ty-tt	22	STD541431	Nut Lock Hex "W/Ins 5/16-18
9	19131614	Washer 13/32 X 1 X 14 Ga	24	19171912	Washer 17/32 X 1-3/16 X 12 Ga
10	155925	Pan Seat	25	127018X	Bolt Shoulder 5/16-18 X 62
11	166369	Knob Seat Adj. Wingnut			

NOTE: All component dimensions given in U.S. inches
1 inch = 25.4 mm

TRACTOR -- MODEL NUMBER 917.259130

DECALS

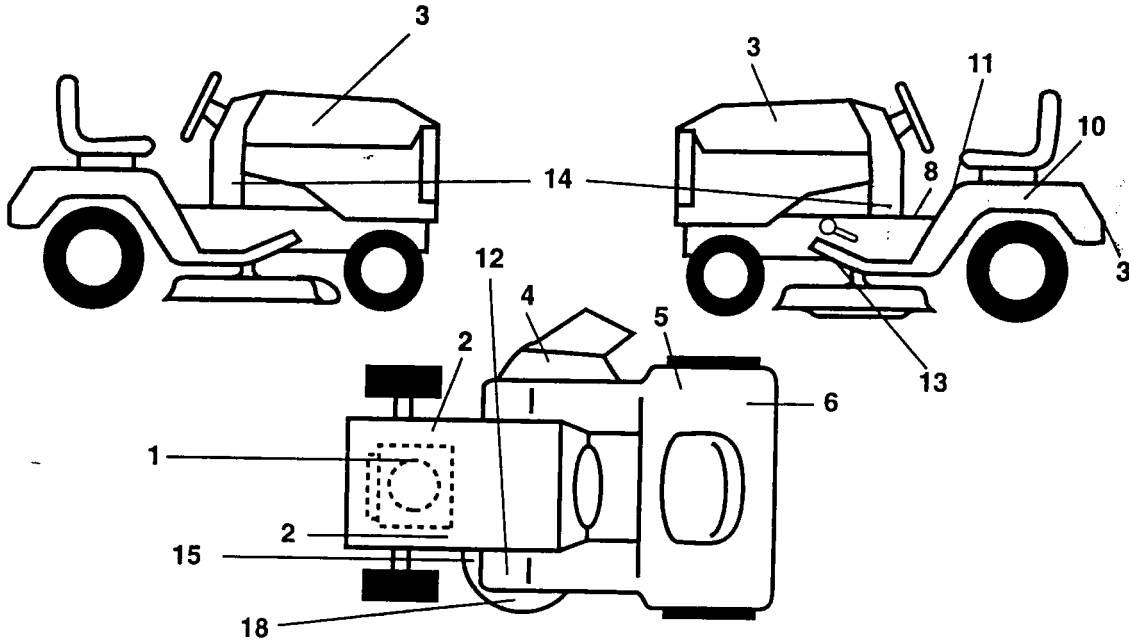

KEY NO.	PART NO.	DESCRIPTION	KEY NO.	PART NO.	DESCRIPTION
1	165387	Decal, Engine	12	159737	Decal, Clutch/brake
2	159736	Decal, Chassis Hot Muffler	13	146046	Decal, V-Belt Dr Sch Tractor
3	163204	Decal, Fender Craftsman White	14	163248	Decal, Panel Dash
4	145494	Decal, Inter Cutfinger	15	136832	Decal, V-Belt Sch
5	145437	Decal, Europ Stand CE	18	133179	Decal, Mower Qc System
6	126187X	Decal, Certification	--	138311	Decal, Handle Lft Height Adjust
8	140837	Decal, Brake Park Sdl	--	162598	Decal, Draw Bar Load Limit
10	145005	Decal, Battery Dngr/Psn Eng	--	168429	Manual Owners Euro
11	145498	Decal, Read Owners	--	168430	Manual Owners Scan

WHEELS & TIRES

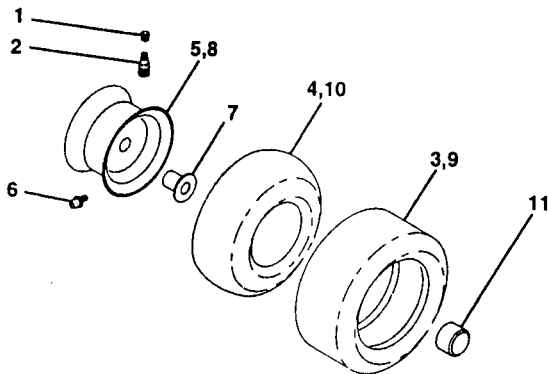

KEY NO.	PART NO.	DESCRIPTION
1	59192	Cap Valve Tire
2	65139	Stem Valve
3	106222X	Tire F Ts 15 X 6 0 - 6 Service
4	59904	Tube Front (Service Item Only)
5	106732X427	Rim Asm 6" f ront White Service
6	278H	Fitting Grease (Front Wheel Only)
7	9040H	Bearing Flange (Front Wheel Only)
8	106108X427	Rim Asm 8" rear White Service
9	124635X	Tire R Ts 18x8 5-8 C Service
10	7152J	Tube Rear (Service Item Only)
11	104757X	Cap Hub Axle Bik 1 50 X 1 00
--	144334	Sealant, Tire (10 oz. Tube)

NOTE: All component dimensions given in U.S. inches
1 inch = 25.4 mm

TRACTOR -- MODEL NUMBER 917.259130

MOWER DECK

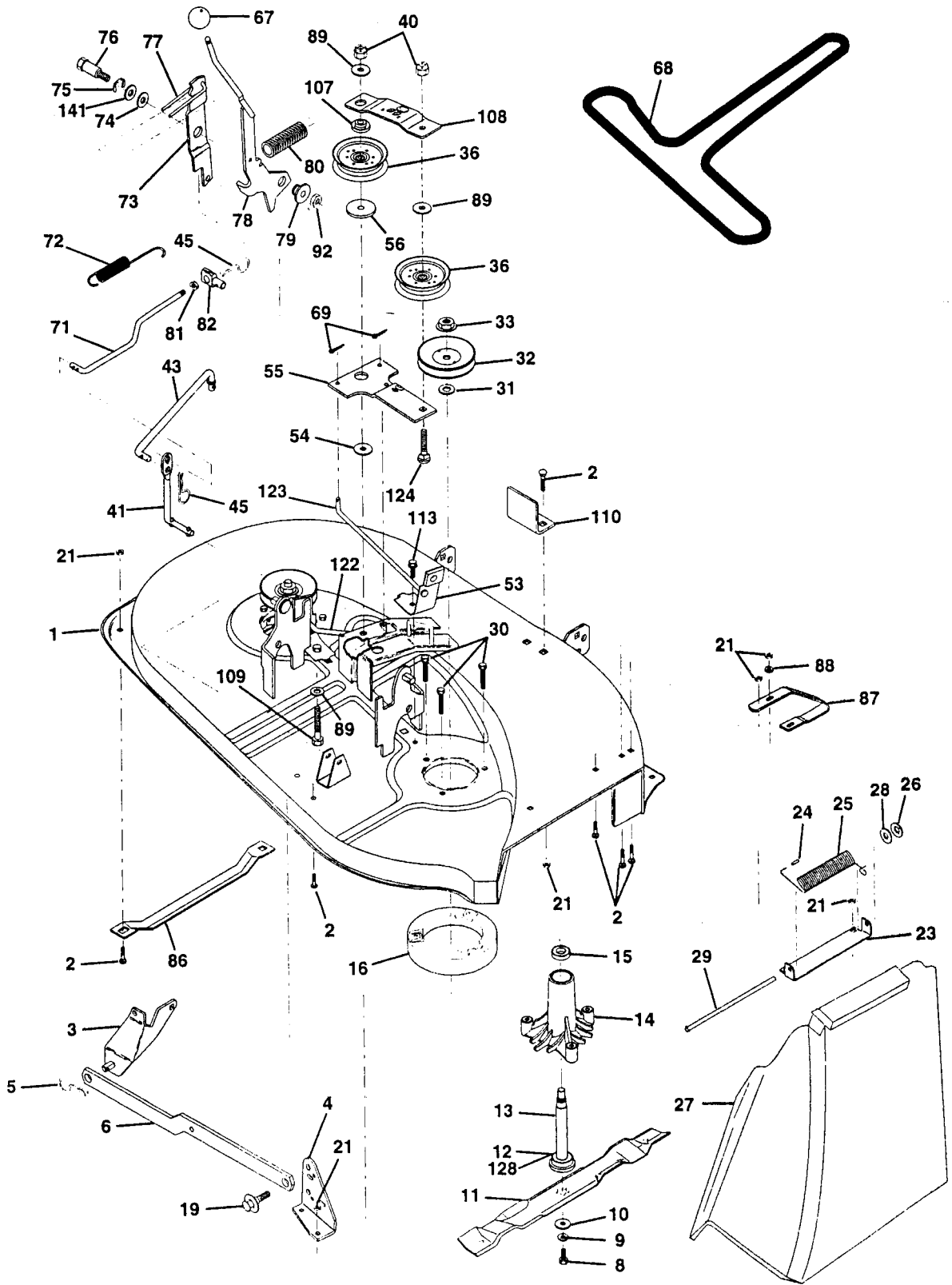

TRACTOR - - MODEL NUMBER 917.259130

MOWER DECK

KEY NO.	PART NO.	DESCRIPTION	KEY NO.	PART NO.	DESCRIPTION
1	142829	Mower Housing Assembly	56	122052X	Spacer, Retainer 1-3/4
2	STD533107	Bolt, Carriage 5/16-18 x 3/4	67	162113	Knob
3	138017	Bracket Asm. Fram Sway Bar 38/42	68	144200	Belt
4	138440	Bracket, Asm. Deck Sway Bar 38"	69	STD560907	Pin, Cotter 3/32 x 3/4
5	STD624008	Retainer, Spring	71	142427	Rod, Clutch, Primary
6	130832	Asm. Suspension Rear	72	131870	Spring, Return
8	850857	Bolt, Hex 3/8-24 x 1-1/4 Grade 8	73	127847	Arm, Clutch, Secondary
9	STD551137	Washer, Lock, Hvy Hlcl Spring 3/8	74	121748X	Washer 25/32 x 1-5/8 x 16 Gauge
10	140296	Washer, Hard Blade Mower Vented	75	12000029	Ring, Klip
11	134148	Blade, Mower, Mulching 38"	76	128903	Bolt, Shoulder
12	129895	Ball Bearing	77	127845	Keeper, Spring
13	137645	Shaft and Bearing Assembly (Includes Key Number 15)	78	160571	Arm, Clutch, Primary
14	128774	Mandrel Housing, Vented	79	127498	Bushing
15	110485X	Ball Bearing, Mandrel	80	153701	Spring
16	140329	Stripper, Mower, Vented	81	STD541237	Nut Hex Jam 3/8-16 UNC
19	132827	Bolt, Shoulder	82	142028	Trunnion Adj 94
21	STD541431	Nut, Crownlock 5/16-18	86	7631J	Runner, LH
23	137607	Bracket, Mower Deflector	87	128772	Runner, RH
24	105304X	Cap, Sleeve	88	19111216	Washer 11/32 x 3/4 x 16 Gauge
25	123713X	Spring, Deflector	89	19131612	Washer 13/32 x 1 x 12 Gauge
26	110452X	Nut, Push	92	STD541437	Nut Lock Hex w/Ins 3/8-16 UNC
27	106736X	Shield, Deflector	107	133502	Spacer, Retainer
28	19111016	Washer 11/32 x 3/4 x 16 Gauge	108	133503	Stiffener, Idler Arm
29	106735X	Rod, Hinge	109	74760640	Bolt, Hex Head 3/8-16 x 2-1/2
30	157722	Screw, Thdrol Washer Hd	110	142587	Upstop Deck Front 38"
31	129963	Washer, Spacer	113	17490512	Screw, Hex Head, Thd., Roll. 5/16-18 x 3/4
32	153532	Pulley, Mandrel	122	131289	Rod, Brake, LH
33	137266	Nut, Flangelock 9/16	123	131288	Rod, Brake, RH
36	131494	Pulley, Idler, Flat	124	STD533717	Bolt, Carriage 3/8-16 x 1-3/4
40	STD541437	Nut, Crownlock 3/8-16	128	153390	Washer Felt
41	133551	Rod, Pivot	141	6266H	Washer Thrust .75 x 1.230
43	133504	Rod, Clutch, Secondary	--	130794	Mandrel Assembly (Includes Key Numbers 12-15, 17-19, 31 and 33)
45	STD624003	Retainer, Spring	--	142820	Mower Deck, Complete
53	130840	Brake Assembly			
54	133943	Washer Hardened			
55	133840	Idler Arm Assembly			

NOTE: All component dimensions given in U.S.inches
1 inch = 25.4 mm

TRACTOR - - MODEL NUMBER 917.259130
PEERLESS TRANSAXLE - - MODEL NUMBER 205-544C

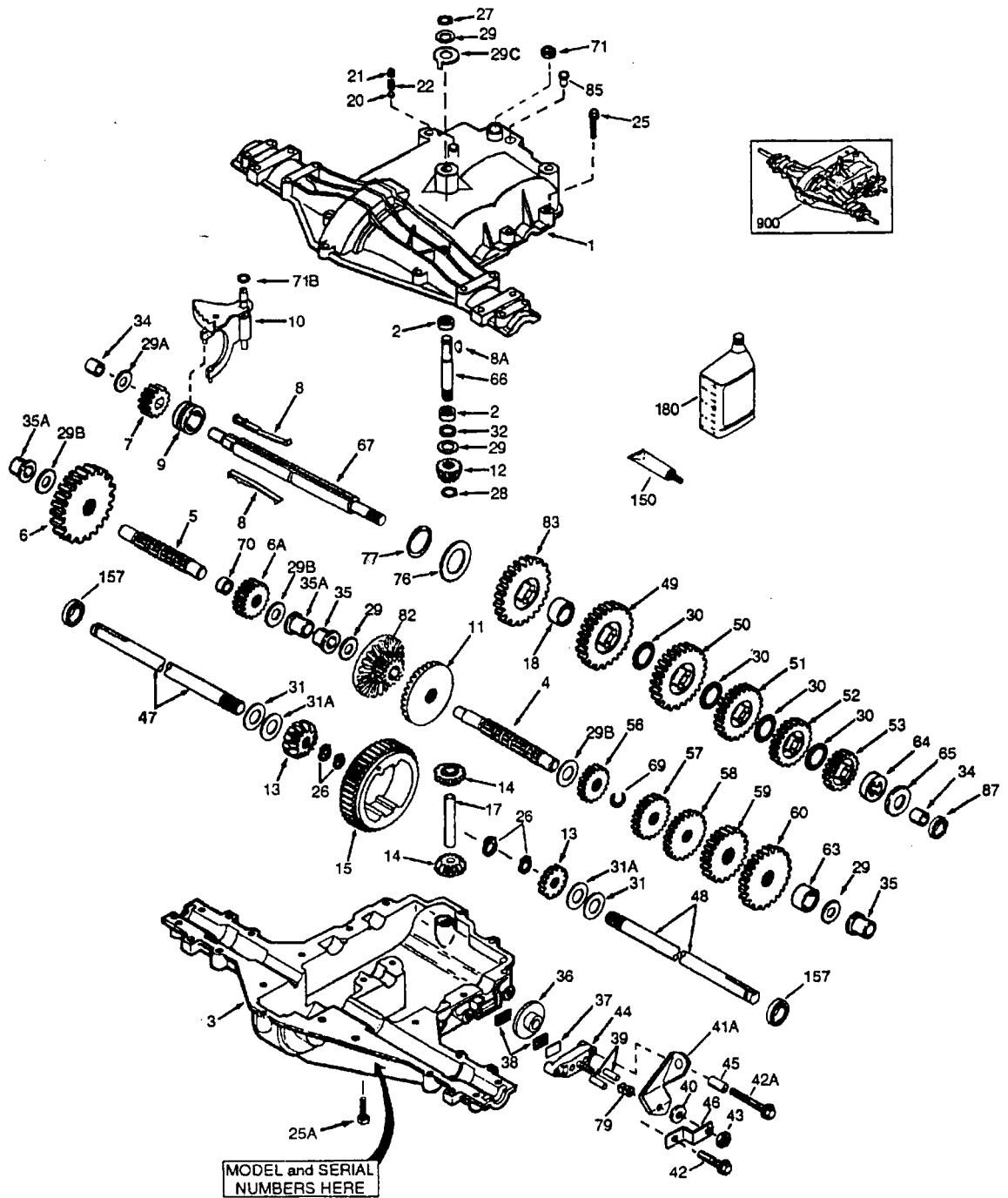

TRACTOR - - MODEL NUMBER 917.259130
PEERLESS TRANSAXLE - - MODEL NUMBER 205-544C

REF NO.	PART NO.	DESCRIPTION	REF NO.	PART NO.	DESCRIPTION
1	772147	Transaxle Cover	39	786026	Dowel Pin
2	780086A	Needle Bearing 5 / 8"	40	792076A	Flat Washer .312 ID x .059W
3	770128	Transaxle Case	41A	790079	Brake Lever
4	776395	Countershaft	42	792073A	Screw 1 / 4 - 20 x 1 - 1 / 4"
5	776409	Output Shaft	42A	792085A	Screw 1 / 4 - 20 x 2 - 1 / 4"
6	778364	Spur Gear (38 teeth)	43	792075	Locknut 5 / 16 - 24
6A	778369	Spur Gear (15 teeth)	44	790025	Brake Pad Holder
7	778330	Spur Gear (11 teeth)	45	786066	Spacer .2625 x 1.0
8	792180	Shift Key	46	786086	Brake Lever Bracket
8A	792047	Woodruff Key #9	47	774690	Axle (11 - 15 / 16 " long)
9	784352	Shift Collar	48	774691	Axle (16 - 1 / 2" long)
10	784378	Shift Rod & Fork	49	778356	Spur Gear (29 teeth)
11	778334	Bevel Gear (30 teeth)	50	778354	Spur Gear (23 teeth)
12	778309	Input Bevel Pinion (13 teeth)	51	778352	Spur Gear (19 teeth)
13	778368	Bevel Gear (13 teeth) (Include. 14)	52	778350	Spur Gear (16 teeth)
14	778368	Bevel Pinion (13 teeth) (Include 13)	53	778346	Spur Gear (15 teeth)
15	778370	Ring Gear (43 teeth)	53	778346	Spur Gear (15 teeth - steel)
17	786188	Drive Pin	56	778355	Spur Gear (11 teeth)
18	786102	Spacer 1.130 x .695	57	778353	Spur Gear (17 teeth)
20	792077A	Ball 5 / 6" dia	58	778351	Spur Gear (21 teeth)
21	792078	Set Screw 3 / 8-16 x 3 / 8"	59	778349	Spur Gear (24 teeth)
22	792079	Spring .310 OD x .625 L	60	778345	Spur Gear (25 teeth)
25	792073A	Screw 1/4 - 20 x 1-1 / 4"	63	786071	Countershaft Spacer 1 - 1 / 8" x 3 / 8"
25A	792177	Screw 1 / 4 - 20 x 1 - 3 / 8"	64	786072	Brake Shaft Spacer 1 - 3 / 8" x 3 / 8"
26	792125	Retaining Ring (pkg of 2)	65	780189	Flat Washer .563 ID x .062W
27	792035	Retaining Ring	66	776422	Input shaft
28	788040	Retaining Ring	67	776396	Shifter & Brake shaft
29	780072	Thrust Washer .627 ID x .031W	69	792170	Retaining Ring
29A	780160	Thrust Washer .563 ID x .031W	70	786187	Spacer .890
29B	780051	Thrust Washer .762 ID x .031W	71	788069	Square Cut Ring
29C	780199	Anti -Rotation Washer .632	71B	788092	"O" Ring
30	780108	Cup Washer 1.127 ID x .032W	76	780090	Flat Washer 1.128 ID x .058W
31	780001	Flat Washer .750 ID x .056 (Use as Needed)	77	788078A	Inverted Retaining Ring
31A	780195	Flat Washer .750 ID x .062W	79	792144	Spring .430 OD x .5000 L
32	788083	Oil Seal 5 / 8"	82	778333	Bevel & Spur Gear (30 & 13 teeth)
34	780194	Bushing .563	83	778338	Spur Gear (27 teeth)
35	780193	Flanged Bushing 5 / 8" ID	85	792154	Oill Fill Plug
35A	780197	Flanged Bushing .751	87	788089A	Oil Seal 9 / 16"
36	790075	Brake Disk	150	788093A	Liquid Gasket RTV Silicone
37	790007	Brake Pad Plate	157	788088A	Oil Seal 3 / 4"
38	799021	Brake Pad (pkg of 2)	180	730229A	Gear Oil 80W90
			900	794711	Replacement MST-205-544C Transaxle

NOTE: All component dimensions given in U.S. inches 1 inch = 25.4 mm

TRACTOR - - MODEL NUMBER 917.259130
BRIGGS & STRATTON ENGINE-MODEL NUMBER 28R707, TYPE NUMBER 1140-E1

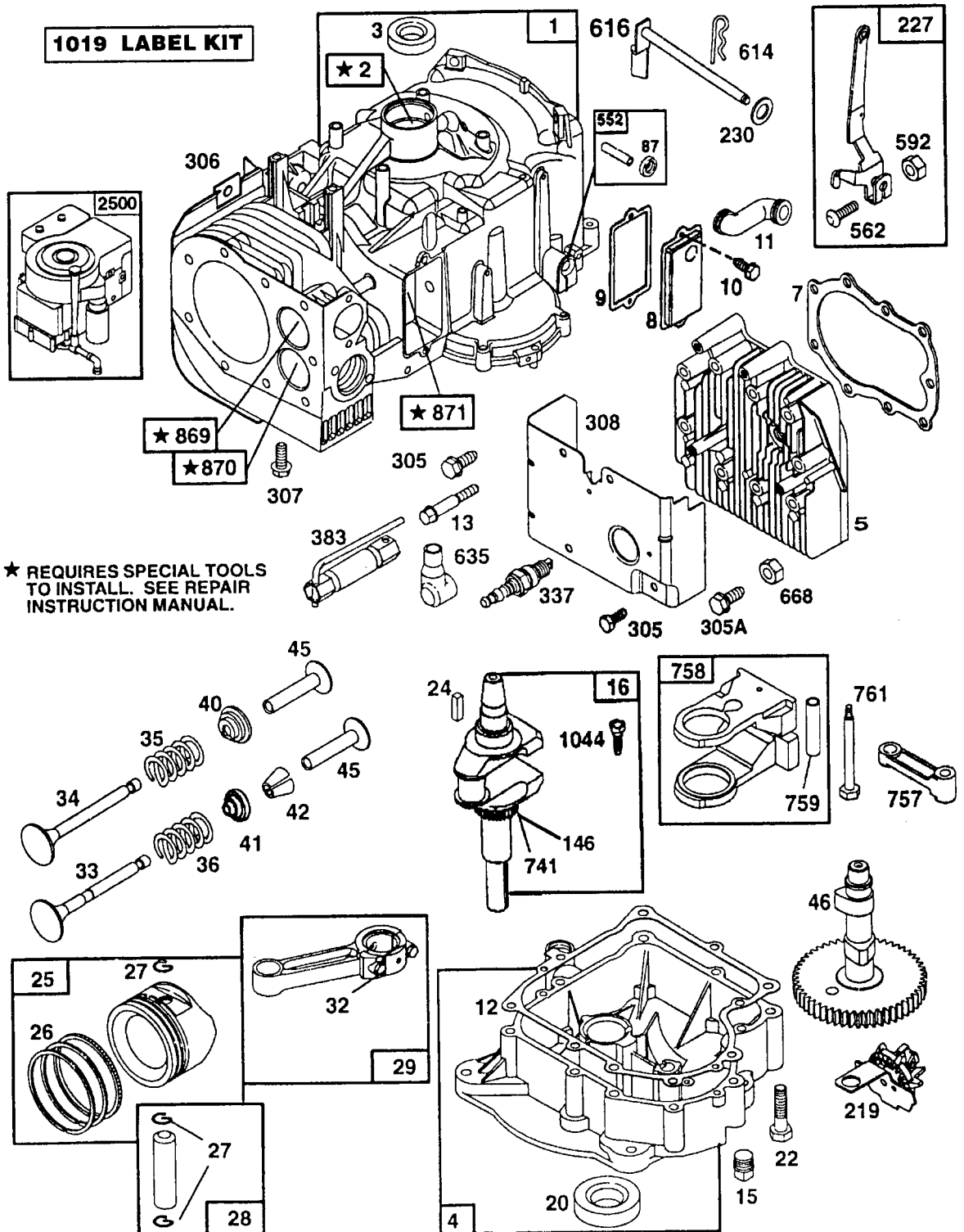

TRACTOR -- MODEL NUMBER 917.259130
BRIGGS & STRATTON ENGINE-MODEL NUMBER 28R707, TYPE NUMBER 1140-E1

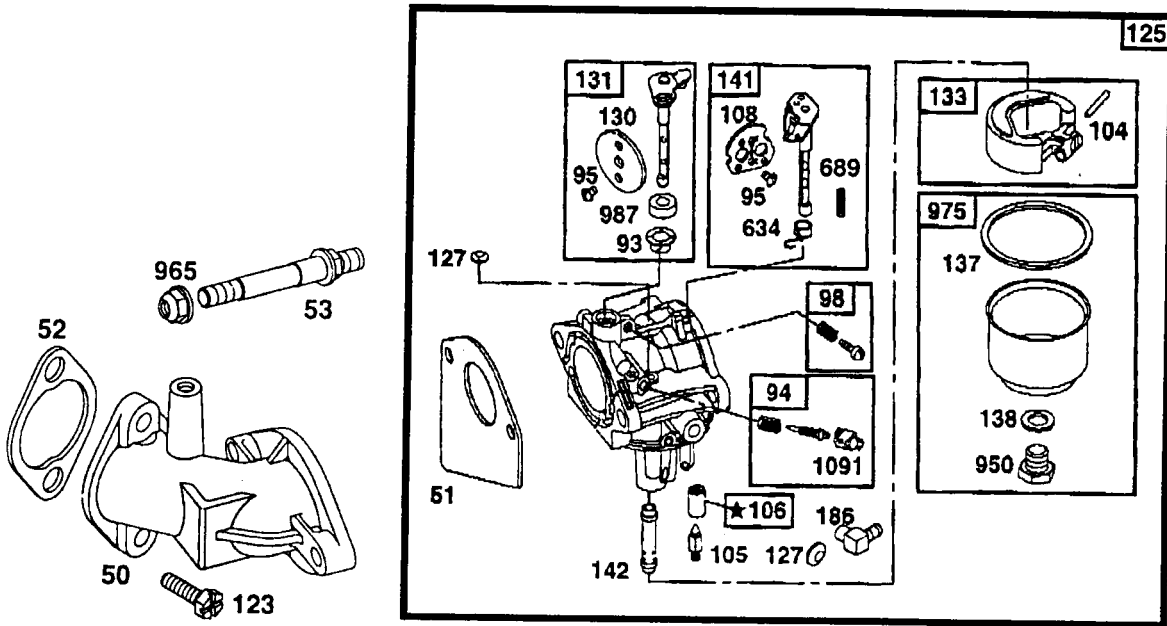

★ REQUIRES SPECIAL TOOLS TO INSTALL. SEE REPAIR INSTRUCTION MANUAL.

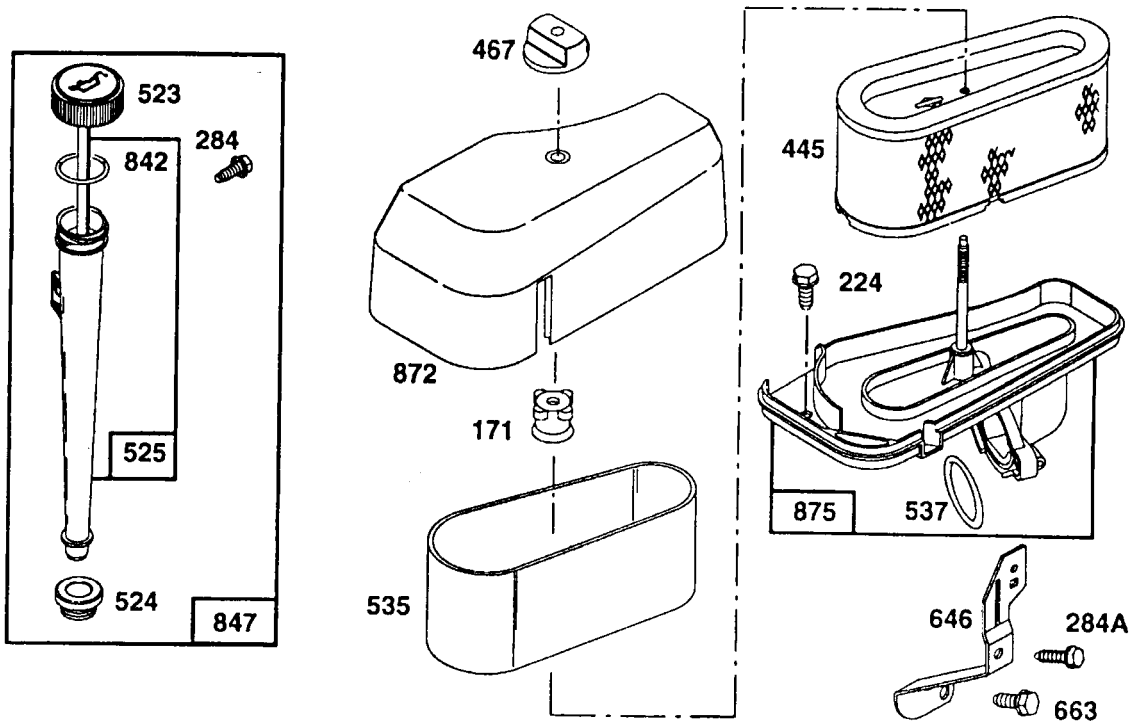

TRACTOR - - MODEL NUMBER 917.259130
BRIGGS & STRATTON ENGINE-MODEL NUMBER 28R707, TYPE NUMBER 1140-E1

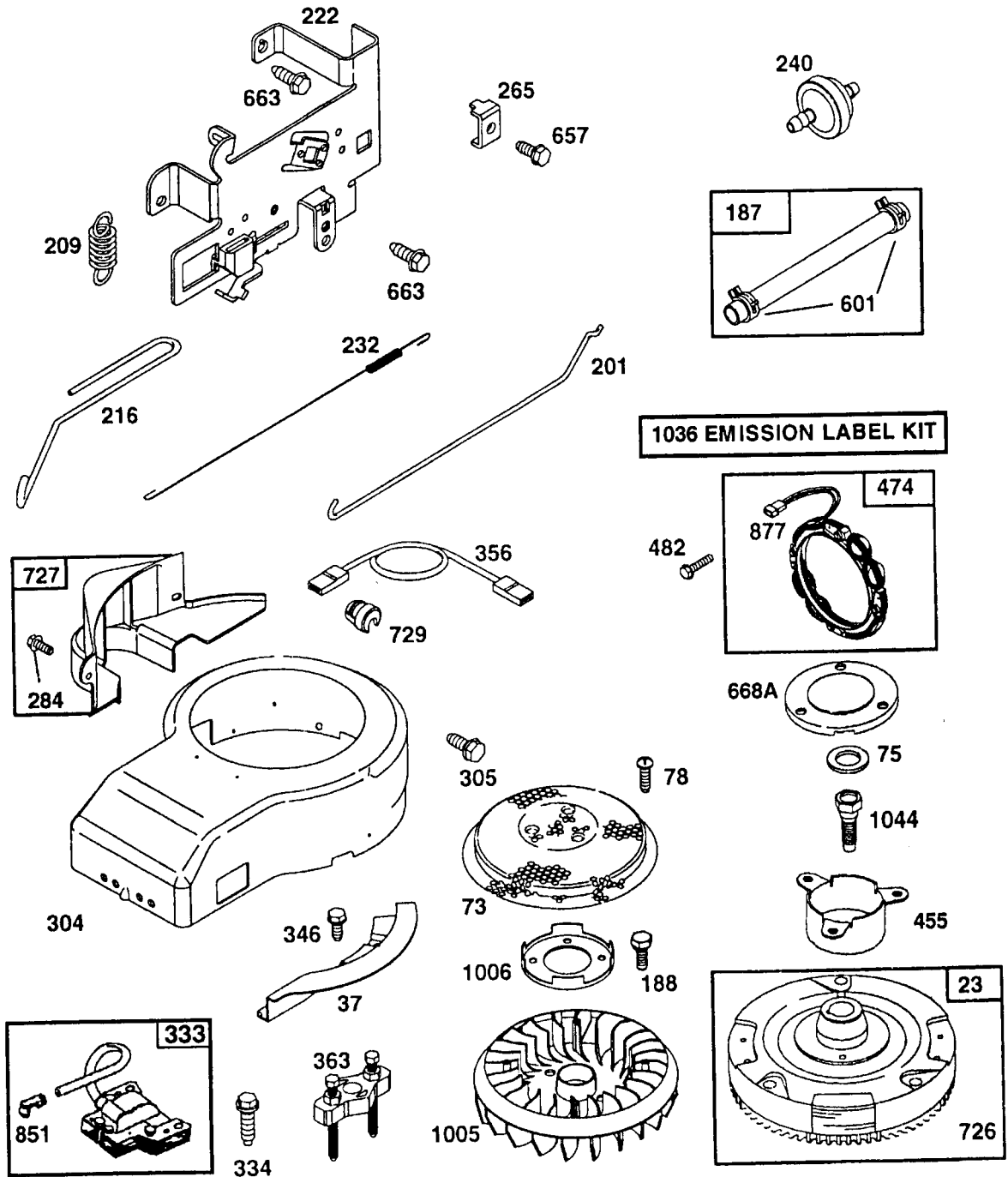

TRACTOR - - MODEL NUMBER 917.259130

BRIGGS & STRATTON ENGINE-MODEL NUMBER 28R707, TYPE NUMBER 1140-E1

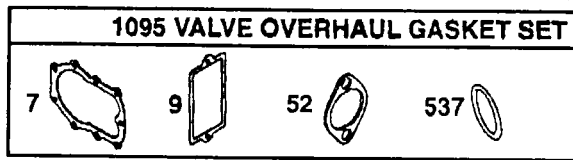
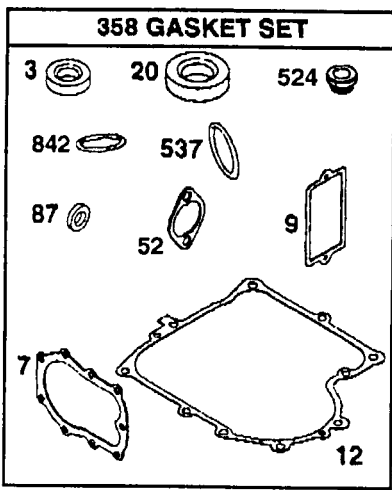
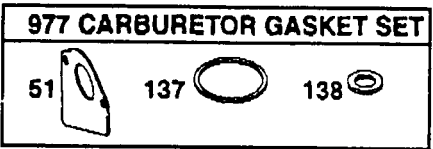
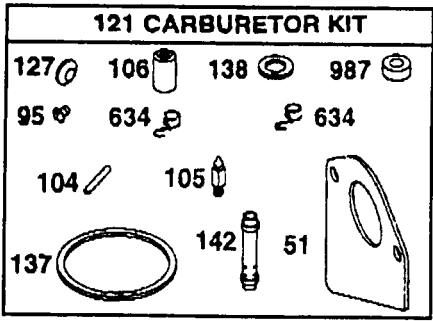
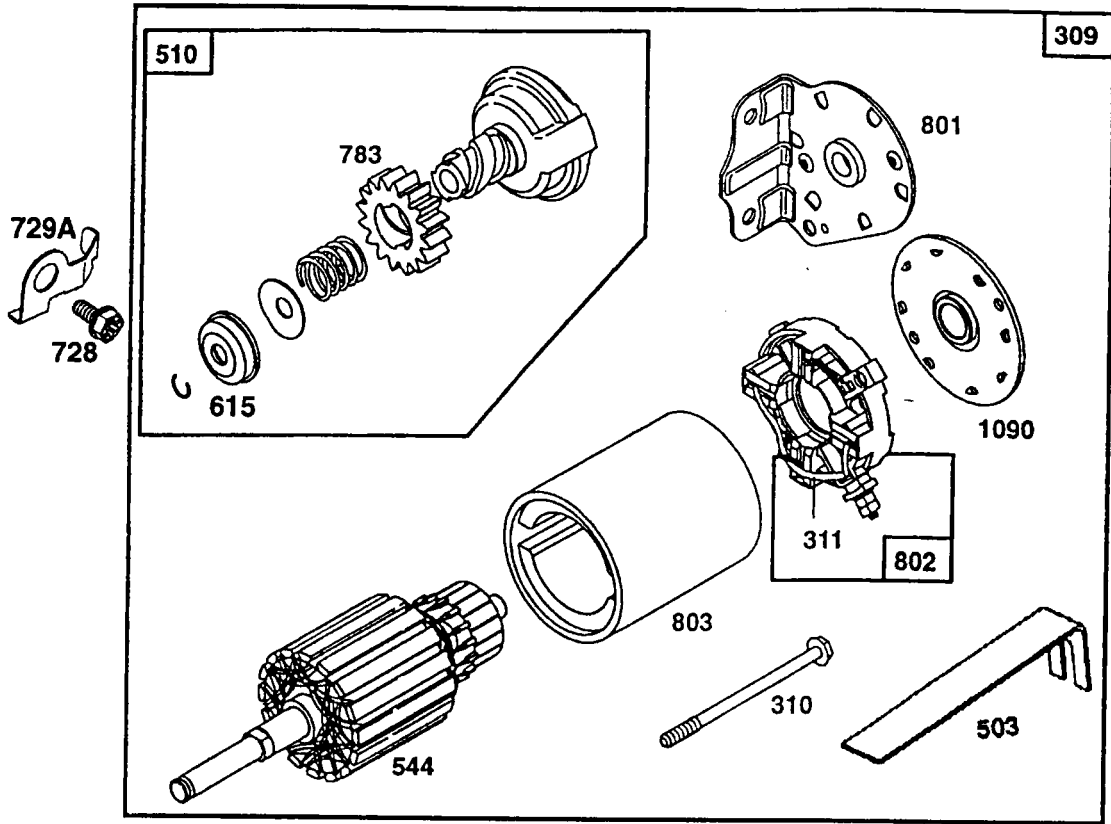

TRACTOR - - MODEL NUMBER 917.259130

BRIGGS & STRATTON ENGINE-MODEL NUMBER 28R707, TYPE NUMBER 1140-E1

KEY NO.	PART NO.	DESCRIPTION	KEY NO.	PART NO.	DESCRIPTION
1	496413	Cylinder Assembly	78	94626	Screw, Phillips
2	399265	Bearing, Cylinder	87	491323	* Seal, Governor
3	391086	* Seal, Oil	93	281346	Bushing, Throttle Shaft
4	494238	Base, Engine	94	498030	Valve, Needle
5	494240	Head, Cylinder	95	94098	** Screw, Throttle
7	271866	ø* Gasket, Cylinder Head	98	495800	Screw, Idle Adjust
8	495735	Breather Assembly (Includes Mounting Gasket)	104	231789	** Pin, Float Hinge
9	27803	ø* Gasket, Valve Cover	105	231855	** Valve, Inlet Needle
10	94621	Screw, Sems	106	231854	** Seat, Inlet
11	280100	Tube, Breather	108	224540	Valve, Choke
12	271916	* Gasket, Crankcase Cover, 1/64"	121	499220	Carburetor Kit
	271997	* Gasket, Crankcase Cover, .005"	123	94913	Screw, Elbow Mounting
	271996	* Gasket, Crankcase Cover, .009"	125	498027	Carburetor
13	94622	Screw, Cylinder Head	127	- - -	** Plug, Welch (Sold in Kit Only)
15	94239	Plug, Oil Drain	130	224539	Valve, Throttle
16	498971	Crankshaft	131	494379	Shaft, Throttle
20	291675	* Seal, Oil	133	494381	Float, Carburetor
22	94624	Screw, Sems, Base Mounting	137	281165	*** Gasket, Float Bowl
23	492326	Flywheel	138	281164	*** Washer, Float Bowl
24	222698	Key, Flywheel	141	495097	Shaft, Choke
25	394661	Piston Assembly, Standard Size	142	497736	** Nozzle, Carburetor
	394662	Piston Assembly, .010" Oversize		497737	Nozzle, Carburetor (High Altitude)
	394663	Piston Assembly, .020" Oversize	146	94196	Key, Timing
	394664	Piston Assembly, .030" Oversize	171	281051	Nut, Air Cleaner
26	391780	Ring Set, Standard Size	186	493496	Elbow, Fuel Pipe
	392331	Ring Set, Standard Size, Chrome	187	298049	Line, Fuel (Cut to Suit)
	391781	Ring Set, .010" Oversize	188	94627	Screw, Sems
	391782	Ring Set, .020" Oversize	201	262767	Link, Governor
	391783	Ring Set, .030" Oversize	209	260871	Spring, Governor
27	260924	Lock, Piston Pin	216	262766	Link, Choke
28	299691	Pin, Piston, Standard Size	219	490815	Gear, Governor
	391286	Pin, Piston, .005" Oversize	222	495611	Plate, Governor Control
29	490348	Rod, Connecting	224	94729	Screw, Hex Head
	490469	Rod, Connecting, .020" Undersize	227	493935	Lever Assembly, Governor
32	94671	Screw, Connecting Rod	230	94927	Washer, Governor Crank
33	262246	Valve, Exhaust	232	262785	Spring, Governor Link
34	262247	Valve, Intake	240	394358	Filter, Fuel
35	65906	Intake Exhaust Valve	265	221535	Clamp, Casing
36	26828	Spring, Valve			* Included in Gasket Set (494241)
37	224502	Guard, Flywheel			** Included in Carburetor Kit (499220)
40	221596	Retainer, Intake Valve			*** Included in both Carburetor Kit (499220), and Carburetor Gasket Set (494385)
41	292260	Rotocoil, Exhaust Valve			
42	494553	Retainer, Rotocoil			
45	262248	Tappet, Valve			
46	212897	Gear, Cam			
50	213819	Carburetor, Elbow			ø Included in Valve Overhaul Gasket Set
51	272465	*** Gasket, Carburetor			
52	272554	ø* Gasket, Carburetor			
53	94637	Stud, Carburetor Mounting			
73	224948	Screen, Rotating			
75	225136	Washer, Spring			

NOTE: All component dimensions given in U.S. inches 1 inch = 25.4 mm

TRACTOR - - MODEL NUMBER 917.259130
BRIGGS & STRATTON ENGINE-MODEL NUMBER 28R707, TYPE NUMBER 1140-E1

KEY NO.	PART NO.	DESCRIPTION	KEY NO.	PART NO.	DESCRIPTION
284	94903	Screw, Shoulder	729A	225170	Retainer, Wire
284A	94704	Screw, Hex Head	741	262932	Gear, Timing
304	496280	Housing, Blower	757	213998	Link, Counterweight
305	94786	Screw, Hex Head	758	399891	Counterweight Assembly
305A	94881	Screw, Hex	759	298909	Pin, Counterweight
306	224545	Shield, Cylinder	761	94593	Screw, Counterweight
307	94930	Screw, Sems	783	280104	Gear
308	491490	Cover, Cylinder Head	801	394856	Cap, Drive
309	497595	Motor, Starter	802	497605	Cap, End
310	94003	Thru Bolt	803	497604	Housing, Starter
311	497608	Brush Assembly	842	270920	* Seal, Cap
333	492341	Armature, Magneto	847	496415	Tube Assembly, Oil
334	094731	Screw, Sems	851	493880	Terminal, Ignition Cable
337	802592	Plug, Spark	869	261463	Seat, Intake Valve
346	94896	Screw, Hex Head	870	262924	Seat, Exhaust Valve
356	494328	Wire Assembly	871	261961	Guide, Exhaust Valve
358	494241	Gasket Set		231218	Guide, Intake Valve, Brass
363	19203	Puller, Flywheel	872	281361	Cover, Air Cleaner
383	89838	Wrench, Spark Plug	875	494237	Body, Air Cleaner
445	496894	Cartridge, Air Cleaner	877	393456	Diode Assembly
455	221561	Cap, Flywheel	950	94642	Screw, Fuel Bowl
467	493903	Knob, Air Cleaner	965	94010	Nut, Hex
474	393474	Stator, Alternator	975	495933	Bowl, Float
482	93621	Screw, Sems	977	494385	Carburetor Gasket Set
503	806000	Strap, Starter	987	281166	** Seal, Throttle Shaft
510	497606	Starter Drive Group	1005	281400	Fan, Flywheel
523	495230	Dipstick, Oil	1006	224413	Retainer, Fan
524	281370	* Seal, Oil	1019	491252	Label Kit
525	496113	Tube, Oil Filler	1036	499362	Label, Kit, Emission
535	272403	Element, Filter	1044	94673	Screw, Hex Head
537	281106	ø* O-Ring, Air Cleaner	1090	497607	Retainer, Brush
544	497603	Armature, Starter	1091	281364	Cap, Limiter
552	491986	Bushing, Governor Crank	1095	498539	Gasket Set, Valve Overhaul
562	94907	Bolt, Governor Lever	2500	28R707-1140	Replacement Engine
592	231978	Nut, Hex	— —	496050	Replacement Shortblock
601	93053	Clamp, Fuel Pipe			
614	93306	Pin, Cotter			
615	263080	Retainer			
616	495157	Crank, Governor			
634	494453	* Seal, Spring Assembly			
635	66538	Elbow, Spark Plug			
646	224546	Brace, Air Cleaner			
657	94906	Screw, Sems			
663	94929	Screw, Hex Head			
668	231109	Spacer			
668A	280848	Spacer			
689	262820	Spring, Friction			
726	392134	Gear, Ring			
727	490324	Cover, Starter			
728	94951	Screw, Torx®			
729	281159	Clip, Lead Wire			

RPM Settings: Low Speed: 1900-2100
High Speed: 3000-3200

* Included in Gasket Set (494241)

** Included in Carburetor Kit (499220)

*** Included in both Carburetor Kit (499220),
and Carburetor Gasket Set (494385)

ø Included in Valve Overhaul Gasket Set

NOTE: All component dimensions given in U.S.
inches 1 inch = 25.4 mm

LIMITED ONE YEAR WARRANTY ON CRAFTSMAN RIDING EQUIPMENT

For one (1) year from the date of purchase, if this Craftsman Riding Equipment is maintained, lubricated and tuned up according to the instructions in the owner's manual, Sears will repair or replace, free of charge, any parts found to be defective in material or workmanship.

This Warranty does not cover:

- Expendable items which become worn during normal use, such as blades, spark plugs, air cleaners, belts, etc.
- Tire replacement or repair caused by punctures from outside objects, such as nails, thorns, stumps, or glass.
- Repairs necessary because of operator abuse, negligence, improper storage or accident or the failure to maintain the equipment according to the instructions contained in the owner's manual.
- Riding equipment used for commercial or rental purposes.

LIMITED 90 DAY WARRANTY ON BATTERY

For ninety (90) days from date of purchase, if any battery included with this riding equipment proves defective in material or workmanship and our testing determines the battery will not hold a charge, Sears will replace the battery at no charge. In-home warranty service on your Craftsman riding equipment is available at no charge for 30 days from the date of purchase. Please contact your nearest service center. After 30 days from the date of purchase, warranty service is available by taking your Craftsman riding equipment to your nearest Sears Service Center. (In-home warranty service will still be available after 30 days from the date of purchase but a standard trip charge will apply). This warranty applies only while this product is in the United States. This Warranty gives you specific legal rights, and you may also have other rights which may vary from state to state.

Sears, Roebuck and Co., D/817 WA, Hoffman Estates, IL 60179

CRAFTSMAN®