



REPAIR PARTS MANUAL
MODEL NO. 259860
Lawn Tractor

46" Kohler 2044

CRAFTSMAN®

HOW TO USE THIS MANUAL

This manual is designed to provide the customer with a means to identify the parts on his/her tractor when ordering repair parts. The illustrations may or may not represent the actual assemblies; therefore, it is not recommended to use this manual as a guide to assemble or disassemble the tractor. Some hardware and parts are drawn larger in order to more readily identify them.

Each tractor has its own model number.

The model number for your tractor can be found on the fender under the seat.

When ordering parts, always give the following information:

- Product - "Tractor"
- Model Number - "259860"
- Part Number
- Part Description

TABLE OF CONTENTS

SCHEMATIC	3
ELECTRICAL	4-5
CHASSIS	6-7
DRIVE	8-9
STEERING WHEEL	10-11
ENGINE	12-13,22-29
SEAT	14
DECALS	15
MOWER LIFT LEVER	16-17
MOWER DECK	18-19
TRANSAXLE	20-21

TRACTOR - - MODEL NUMBER 917.259860

SCHEMATIC

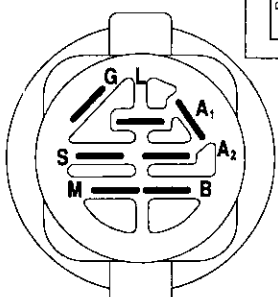
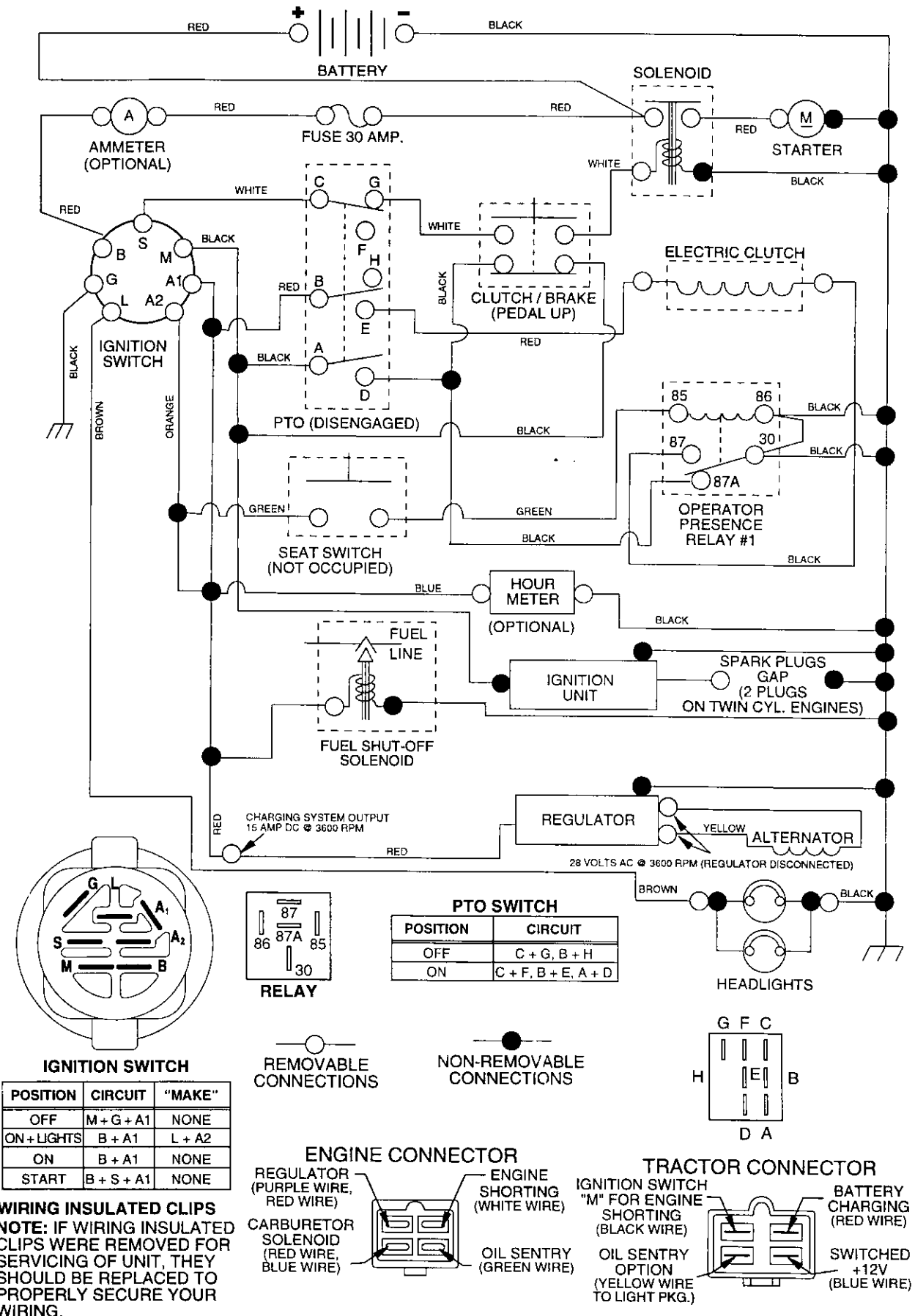

IGNITION SWITCH

POSITION	CIRCUIT	"MAKE"
OFF	M + G + A1	NONE
ON + LIGHTS	B + A1	L + A2
ON	B + A1	NONE
START	B + S + A1	NONE

WIRING INSULATED CLIPS
NOTE: IF WIRING INSULATED CLIPS WERE REMOVED FOR SERVICING OF UNIT, THEY SHOULD BE REPLACED TO PROPERLY SECURE YOUR WIRING.

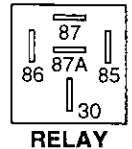

PTO SWITCH

POSITION	CIRCUIT
OFF	C + G, B + H
ON	C + F, B + E, A + D

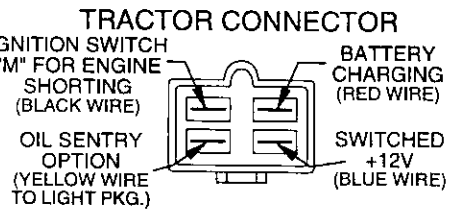
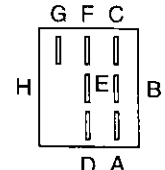
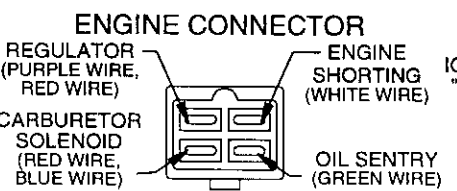
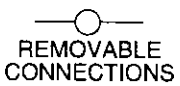

REPAIR PARTS

TRACTOR - - MODEL NUMBER 917.259860

ELECTRICAL

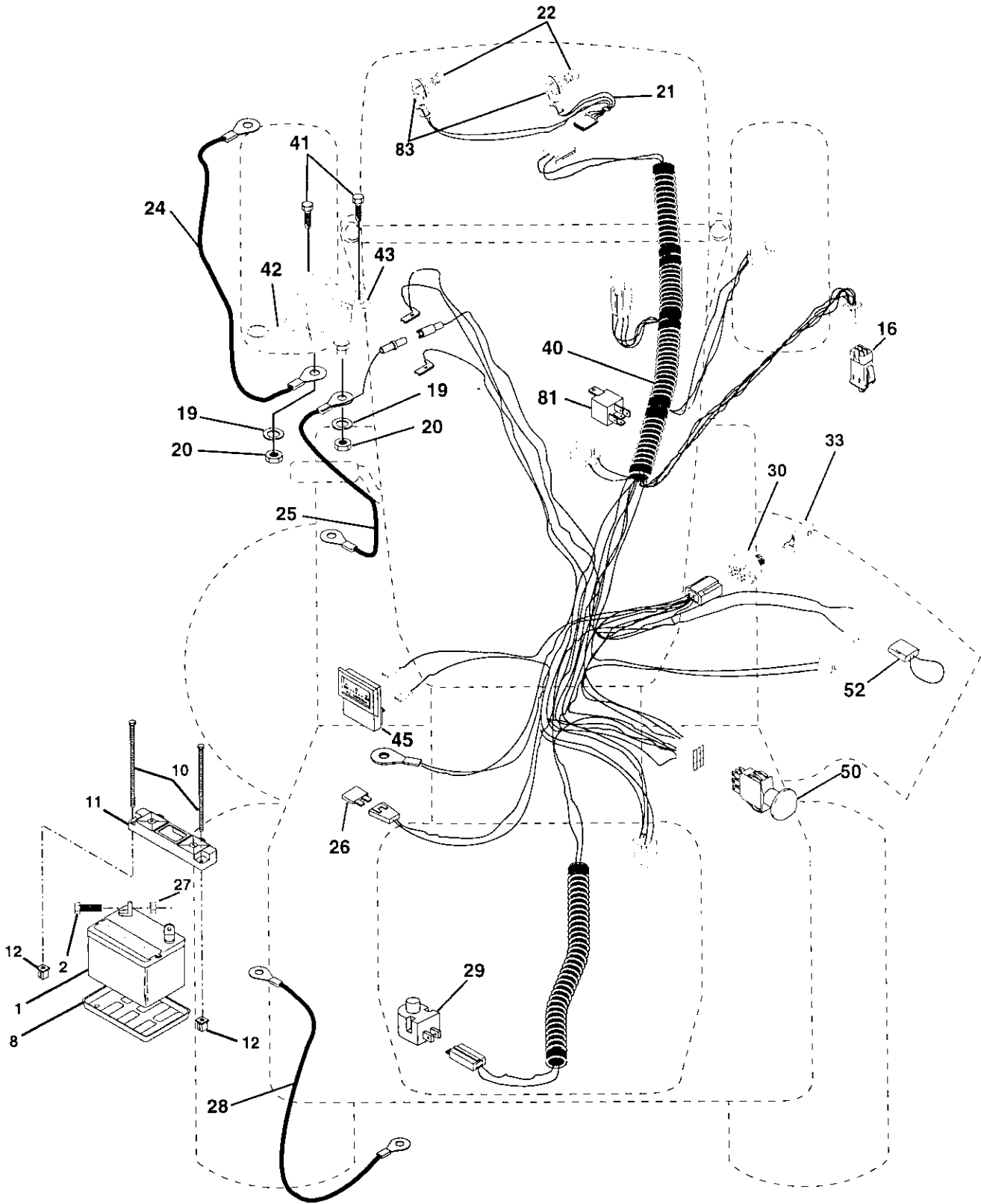

REPAIR PARTS

TRACTOR - - MODEL NUMBER 917.259860

ELECTRICAL

KEY NO.	PART NO.	DESCRIPTION
1	144927	Battery
2	74760412	Bolt Hex Head 1/4-20 x 3/4
8	7603J	Tray, Battery
10	145211	Bolt 1/4-20 x 7.5 Zinc
11	150109	Hold down Battery Dash Mount
12	145769	Nut Push Nylon 1/4"
16	153664	Switch Interlock Push-In
19	STD551125	Washer, Lock 1/4
20	73350400	Nut, Jam Hex 1/4-20
21	166184	Harness Socket Light W/4152J
22	4152J	Bulb Light
24	4014J	Cable, Battery
25	146686	Cable, Battery
26	108824X	Fuse
27	73510400	Nut Keps Hex 1/4-20 Unc
28	157899	Cable, Ground
29	160784	Switch, Plunger
30	163968	Switch, Ign
33	140403	Key, Ignition
40	166176	Harness Ign.
41	17720408	Screw 1/4-20 x 1/2
42	131563	Cover, Terminal
43	145673	Solenoid
45	122822X	Ammeter
50	154963	Switch, PTO
52	141940	Protection Wire Loop
81	109748X	Relay Asm.
83	163996	Bulbholder Asm. Incan descent

NOTE: All component dimensions given in U. S. inches
1 inch = 25/4 mm

REPAIR PARTS

TRACTOR - - MODEL NUMBER 917.259860

CHASSIS AND ENCLOSURES5

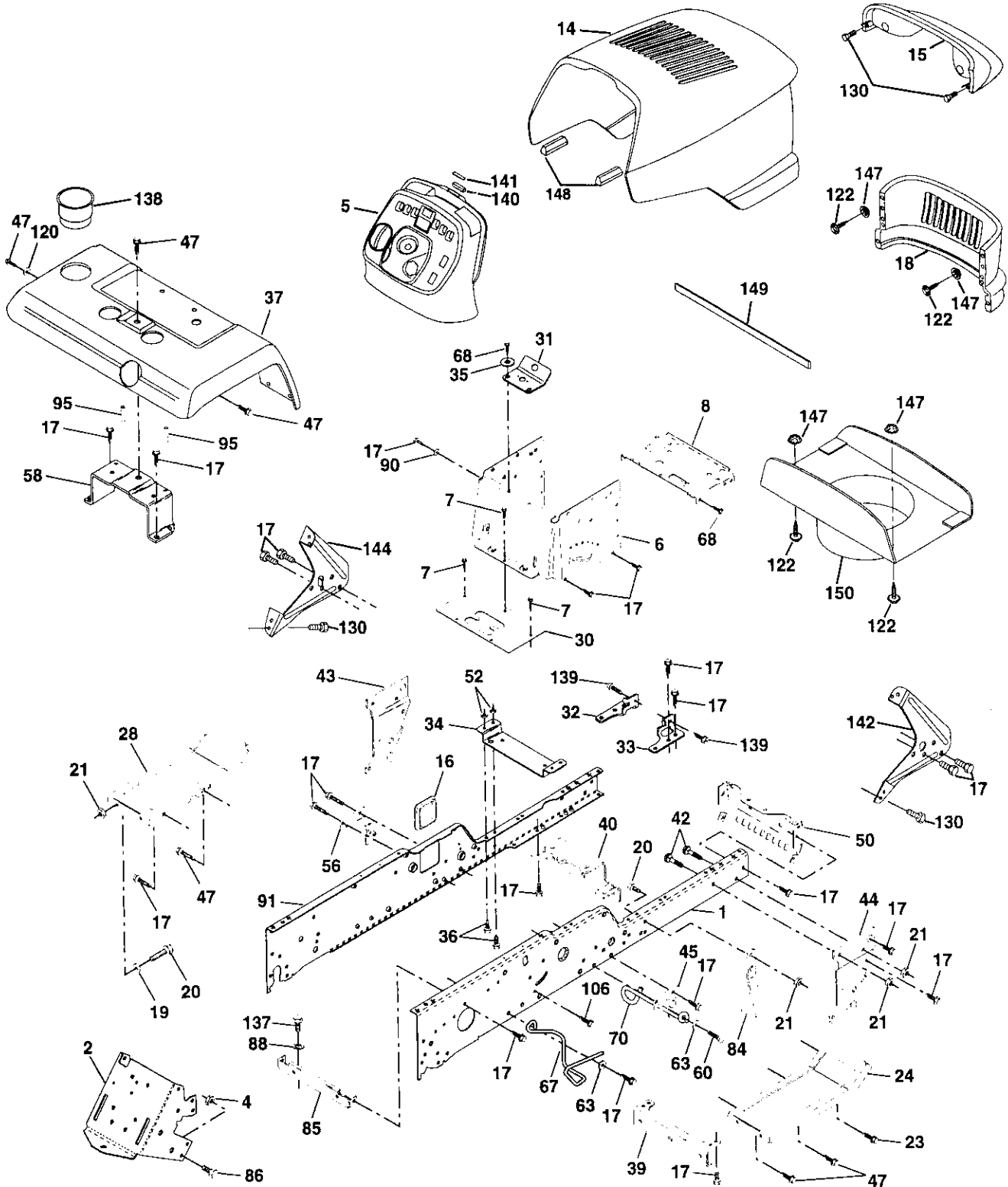

REPAIR PARTS

TRACTOR - - MODEL NUMBER 917.259860

CHASSIS AND ENCLOSURES

KEY NO.	PART NO.	DESCRIPTION	KEY NO.	PART NO.	DESCRIPTION
1	150253	Rail, Frame RH	50	152728	Bracket, Chassis Front
2	140506	Drawbar, Gt	52	STD541431	Nut, Crownlock 5/16-18 Unc
4	73800700	Nut, Lock Hex 7/16 Unc	56	154914	Bracket Asm., Susp Chassis Lh
5	163976	Dash YTGT 2 Cyl	58	137113	Bracket Asm., Fender
6	157882	Dash, Lower Vgt One Piece	60	17490620	Screw Thdrol. 3/8-16 x 1-1/4
7	17720408	Screw, Thd Cut 1/4-20 x 1/2	63	19131614	Washer 13/32 x 1 x 14 Ga.
8	145166	Support, Battery	67	156973	Guide, Belt Gear Drive
14	161023X558	Hood Asm., Pnt Stealth YTGT	68	17490508	Screw Thdrol. 5/16-18 x 1/2
15	160568	Lens Asm Headlight Bar	70	137159	Guide, Belt Mid Span
16	121794X	Cover, Access	84	142992	Stop, Over Center Mower
17	17490612	Screw, Thdrol 3/8-16 x 3/4	85	144911	Bracket, Support Transaxle
18	160564X558	Grille	86	74760716	Bolt Fin Hex 7/16-14 UNC x 1
19	19131312	Washer 13/32 x 13/16 x 12 Ga.	88	STD551143	Washer, Lock Hvy Hlcl Spr 7/16
20	STD523710	Bolt, Fin Hex 3/8-16 x 1	90	STD551237	Washer, Lock External Tooth 3/8
21	STD541437	Nut Crownlock 3/8-16 Unc	91	156586	Rail, Frame Lh
23	17490616	Screw Thdrol 3/8-16 x 1 Ty-Tt	95	105531X	Push Nut, Nylon
24	145243X558	Footrest, RH	106	138776	Screw, Thdrol Hex Head Zinc Mwr
28	145244X558	Footrest, LH	120	19131616	Washer 13/32 x 1 x 16 Ga.
30	145051X014	Saddle, Silkscr Vgt	122	161464	Screw Hex Wshd 8-18 x 7/8
31	161419	Brace, Supt 1-pc VGT Steering	130	164863	Screw Hwhd Hi-Lo #13-16 x 3/4
32	161327	Bracket, Pivot Chassis Lh	137	74780716	Bolt Fin Hex 7/16-14 x 1 Gr. 5
33	161326	Bracket, Pivot Chassis Rh	138	163975X428	Cupholder YTGT
34	142131	Bracket, Engine Support Rear	139	161330	Bolt Shoulder 5/16-18 TT
35	19111116	Washer 11/32 x 11/16 x 16 Ga.	140	163806	Magnet YTGT
36	74780512	Bolt, Fin Hex 5/16-18 x 3/4	141	163805	Striker Plate YTGT
37	163981X558	Fender YTGT PNT WO/SH Cup 558	142	161897	Bracket Dash Rh
39	136961	Bracket, Axle Front	144	161900	Bracket Dash Lh
40	156111	Bracket, Support Axle/Engine	147	162967	Fastener Nut Pal
42	72140608	Bolt, Carriage 3/8-16 x 1	149	164655	Extrusion Bumper
43	136939	Bracket, Spnsn Front Lh	150	161237	Duct Heat Hood
44	136940	Bracket, Spnsn Front Rh			
45	154913	Bracket Asm., Susp Chassis Rh			
47	17490608	Screw Thdrol. 3/8-16 x 1/2			

NOTE: All component dimensions given in U. S. inches
1 inch = 25.4 mm

REPAIR PARTS

TRACTOR - - MODEL NUMBER 917.259860

GROUND DRIVE

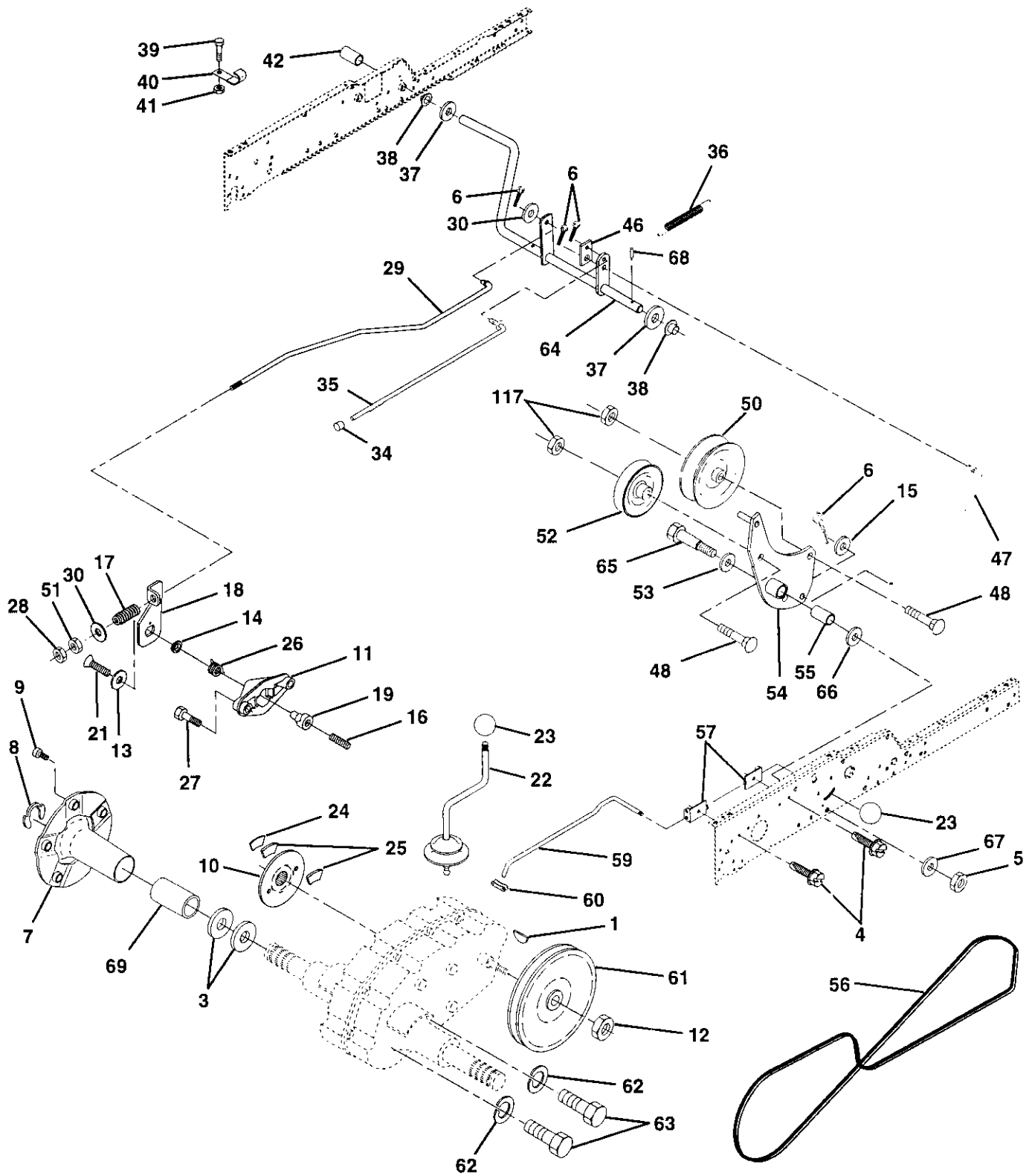

REPAIR PARTS

TRACTOR - - MODEL NUMBER 917.259860

GROUND DRIVE

KEY NO.	PART NO.	DESCRIPTION	KEY NO.	PART NO.	DESCRIPTION
1	9858M1	Key, Woodruff	37	121749X	Washer 25/32 x 1-1/4 x 16 Ga.
3	7563R	Washer, Thrust, Axle	38	150035	Nyliner
4	17490508	Screw Thdrol 5/16-18 x 3/4	39	74321016	Screw, Fin. #10-24 x 1
5	STD541437	Nut, Crownlock 3/8-16	40	5304J	Actuator, Interlock Switch
6	STD561210	Pin, Cotter	41	73661000	Locknut #10-24
7	149176	Wheel, Hub Assembly	42	8883R	Cover, Pedal
8	12000034	Klip, Ring	46	145170	Retainer, Spring
9	140080	Bolt, Hub	47	138228	Clutch Rod
10	142509	Disc, Brake	48	72110612	Bolt, Carriage 3/8-16 x 1-1/2 Gr. 5
11	136927	Yoke, Brake Disc	50	131494	Pulley, Idler, Flat
12	73750800	Nutlock 1/2-20 Unf	51	STD541437	Nut, Crownlock 3/8-16 UNC
13	139419	Washer, Special	52	139123	Pulley, Idler, Grooved
14	138901	Bushing	53	207J	Washer, Hardened
15	STD551037	Wahser 13/32 x 13/16 x 16 Ga.	54	161590	Clutch, Arm Assembly
16	143012	Set, Screw 1/4-28 x 3/4	55	105706X	Bearing, Idler
17	126909X	Spring	56	137153	V-Belt
18	137104	Lever, Brake	57	141756	Bracket, Shift Rod, Hi-Lo
19	136926	Cam, Brake Disc	59	122253X	Shift Rod, Hi-Lo
21	23260412	Screw, Flat Head 1/4-28 x 3/4	60	122268X	Spring Clip, Connecting Link
22	633A109	Gearshift, Lever Assembly	61	137524	Pulley, Transaxle
23	106932X	Knob	62	STD551143	Washer, Lock 7/16
24	136925	Support, Puck Brake	63	74760720	Bolt, Fin Hex 7/16-14 x 1-1/4
25	136923	Puck, Brake Top	64	154752	Shaft, Clutch/Brake Pedal
26	137552	Spring, Return	65	67609	Bolt, Shoulder
27	17490528	Screw, Hex Wsh Thd. 5/16-18 x 1-3/4	66	140296	Washer, Hardened
28	73350600	Nut, Hex Jam 3/8-16	67	19131312	Washer, Flat
29	137213	Brake, Rod	68	5142H	Pin, Roll
30	19131616	Washer 13/32 x 1 x 16 Ga.	69	136327	Hub, Cover
34	124236X	Cap, Plunger	117	73900600	Nut, Lock Flg. 3/8-16 Unc
35	137648	Rod, Parking Brake			
36	149412	Spring, Drive Ground			

NOTE: All component dimensions given in U. S. inches
1 inch = 25.4 mm

REPAIR PARTS

TRACTOR - - MODEL NUMBER 917.259860

STEERING ASSEMBLY

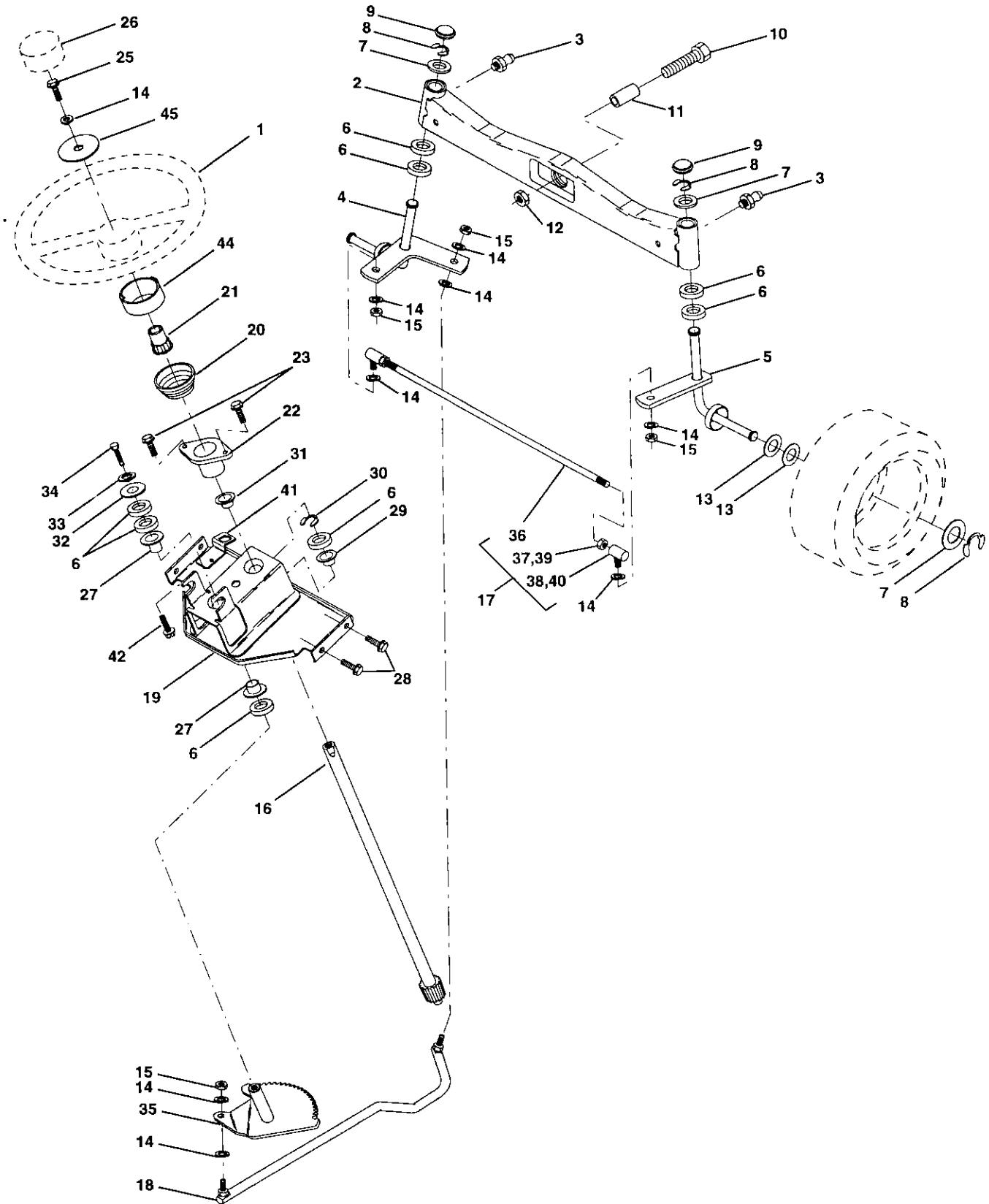

REPAIR PARTS

TRACTOR - - MODEL NUMBER 917.259860

STEERING ASSEMBLY

KEY NO.	PART NO.	DESCRIPTION
1	159944X428	Wheel, Steering
2	137094	Axle Asm., Front
3	6855M	Fitting, Grease
4	161849	Spindle Asm, LH
5	161848	Spindle Asm., RH
6	6266H	Bearing, Race Thrust Harden
7	121748X	Washer 25/32 x 1-5/8 x 16 Ga.
8	12000029	Ring, Klip #T5304-75
9	121232X	Cap, Spindle
10	74781044	Bolt, Fin Hex 5/8-11 x 2-3/4
11	136518	Spacer Bearing Axle Front
12	73901000	Nut, Lock Flange 5/8-11 Unc
13	121749X	Washer 25/32 x 1-1/4 x 16 Ga.
14	STD551137	Washer, Lock Hvy Hlcl Spr 3/8
15	STD541537	Nut, Lock Center 3/8-24 UNF
16	145103	Shaft Asm., Steering
17	137347	Rod Asm., Tie Ball J Ball Vgt (Inc. Key No. 36-40)
18	137155	Draglink, Ball Joint Solid Vgt
19	156011	Support Asm., Steering Vgt
20	163887	Boot, Steering
21	159945	Adapter, Wheel Steering
22	155105	Bushing, Strg. Blk
23	152927	Screw
25	STD523710	Bolt, Fin Hex 3/8-16 x 1 Gr. 5
26	159946X428	Cap , Wheel Steering
27	3366R	Bearing, Col. Strg.
28	17490612	Screw, Thrdrol 3/8-16 x 3/4
29	104239X	Bearing, Flange
30	12000034	Ring, Klip Truarc #5304-75
31	138136	Bushing, Nyliner Snap
32	19111610	Washer 11/32 x 1 x 10 Ga.
33	STD551131	Washer, Lock Hvy Hlcl Spr 5/16
34	STD523107	Bolt, Hex Hd 5/16-18 x 3/4
35	138059	Gear, Sector Steering
36	137156	Tie Rod
37	73360600	Jam Nut RH Thread
38	109850X	Joint Asm. Ball RH Thread
39	73700600	Jam Nut LH Thread
40	109851X	Joint Asm. Ball LH Thread
41	155246	Bracket Switch Interlock VGT 97
42	17490508	Screw Thdrol 5/16-18 x 1/2 Tyt
44	160135	Extension, Steering
45	19132411	Washer 13/32 x 1-1/20 x 11 Ga.

NOTE: All component dimensions given in U.S. inches
1 inch = 25.4 mm

REPAIR PARTS

TRACTOR - - MODEL NUMBER 917.259860

ENGINE

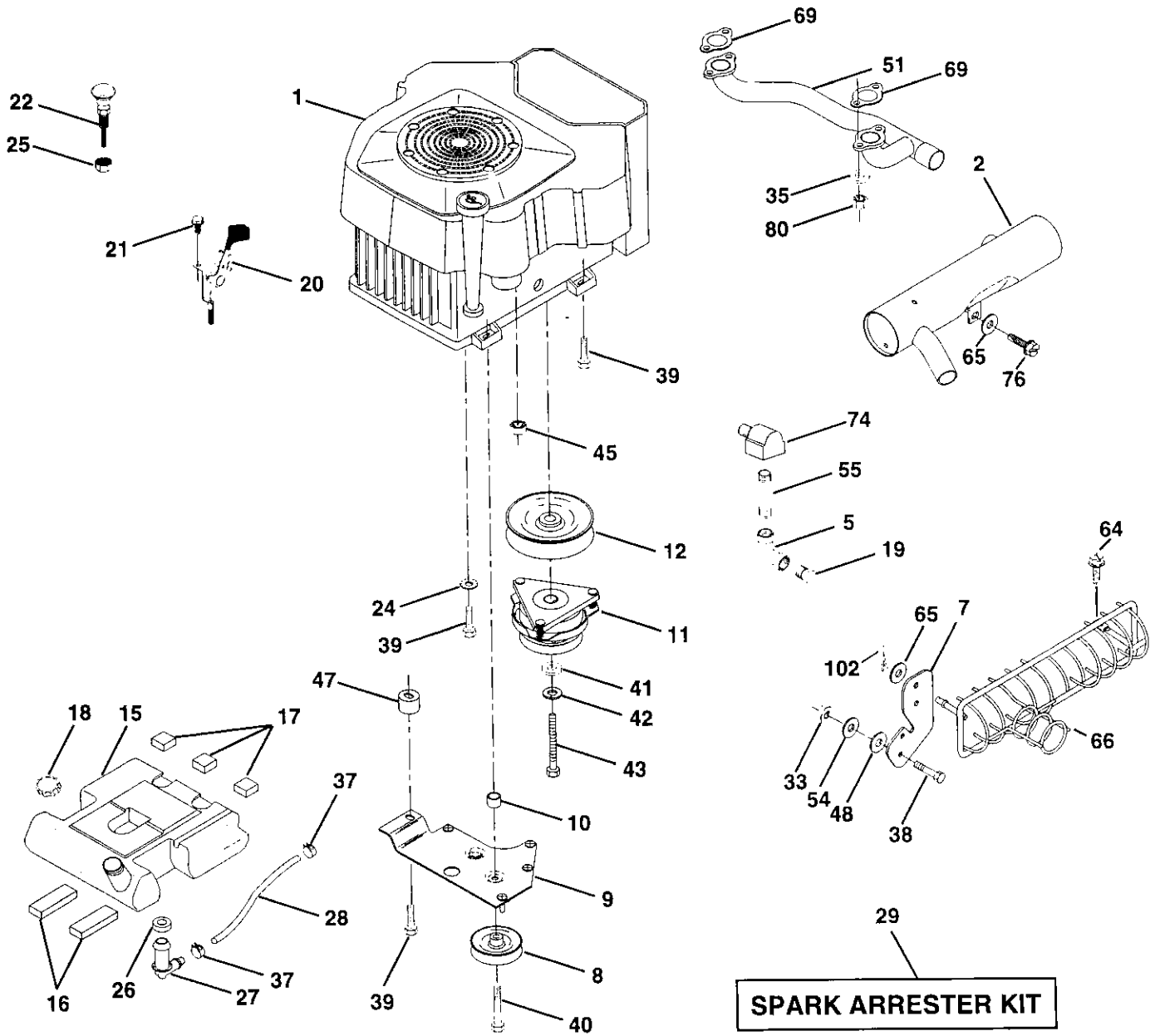

REPAIR PARTS

TRACTOR - - MODEL NUMBER 917.259860

ENGINE

KEY NO.	PART NO.	DESCRIPTION
1	-----	Engine (See Breakdown) Kohler Model No. CV20S-65544
2	161063	Muffler Side
5	13200300	Elbow STD 90 Degree 3/8 - 18 NPT
7	151397	Muffler Asm Guard
8	121361X	Pulley V-Idler
9	150828	Keeper Asm. Belt Engine
10	105432X	Bushing
11	140923	Clutch Electric
12	143996	Pulley Engine VGT Elect Clutch
15	151346	Tank Fuel Rear 3.50 Yt/Gt 96
16	109227X	Pad Spacer
17	106082X	Pad Spacer
18	161493	Cap Asm Fuel W/Gauge
19	13290300	Plug Oil Drain (Order From Engine Manufacturer)
20	164067	Control Throttle
21	164863	Screw HWHD Hi-Lo #13-16 x 3/4
22	164415	Control Choke
24	STD551237	Washer Ext Tooth 3/8
25	73920600	Nut Keps 3/8 - 24 UNF
26	3645J	Bushing
27	139277	Stem Tank Fuel
28	7834R	Fuel Line
29	132920	Spark Arrester Kit
33	STD541437	Nut Lock Hex w/Ins. 3/8 - 16
35	10010500	Washer Split
37	123487X	Clamp Hose
38	74780624	Bolt Fin Hex 3/8 - 16 x 1-1/2
39	17490636	Screw TT 3/8-16 x 2-1/4 UNC
40	17490664	Screw TT 3/8-16 x 4 UNC
41	126197X	Washer 1-1/2 OD X 15/32 ID X .250
42	STD551143	Washer Lock 7/16
43	150280	Bolt Hex 7/16 - 20 X 4 - 1/4 Ga 5
45	128861	Nut Flange 1/4-20 Starter Nut
47	142040	Spacer Engine
48	19132007	Washer 13/32 x 1-1/4 x 7 Ga.
51	161231	Manifold Pipe VGT
54	19131414	Washer Flat 13/32 x 7/8 x 14 Ga.
55	13280336	Nipple Pipe 4-1/2
64	17490616	Screw Thdrol 3/8-16 x 1 TY-TT
65	19131614	Washer 13/32 x 1 x 14 Ga.
66	153113	Cage Muffler
69	24-041-02	Gasket
74	162295	Elbow Street Brass
76	17490612	Screw Thdrol 3/8-16 x 3/4 Ty-TT
80	M73030800	Nut Flange
102	STD624003	Retainer Spring 1" Zinc 1 Cad

NOTE: All component dimensions given in U. S. inches
1 inch = 25.4 mm

REPAIR PARTS

TRACTOR - - MODEL NUMBER 917.259860

SEAT ASSEMBLY

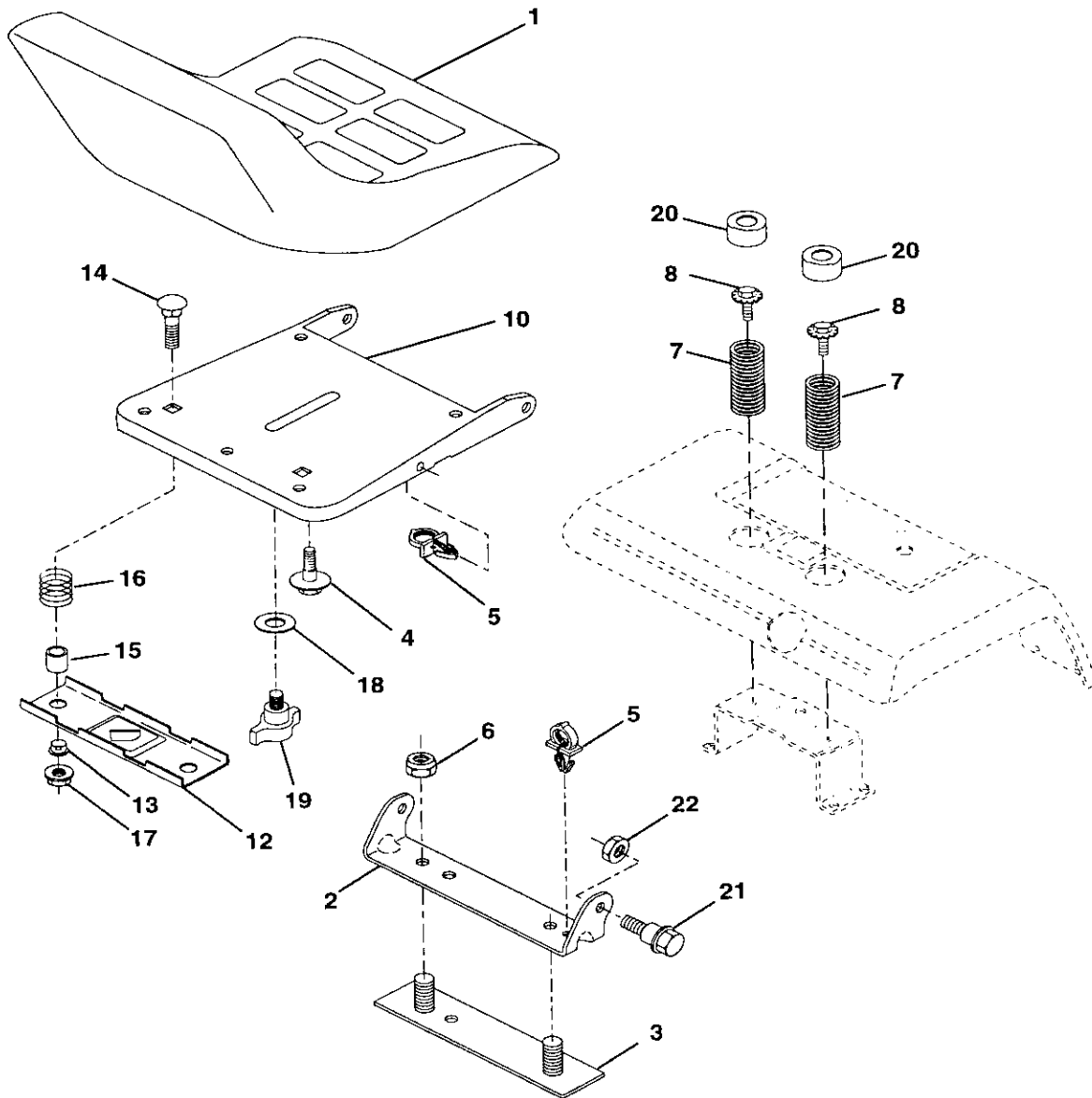

KEY NO.	PART NO.	DESCRIPTION	KEY NO.	PART NO.	DESCRIPTION
1	140124	Seat	13	121248X	Bushing, Snap
2	140551	Bracket, Pivot Seat	14	72050412	Bolt, Carriage 1/4-20 X 1-1/2
3	140675	Strap, Fender	15	121249X	Spacer, Split
4	127018X	Bolt, Shoulder 5/16-18 x .62	16	123740X	Spring, Cprsn
5	145006	Clip, Push In, Hinged	17	123976X	Nut, Lock 1/4 Lge Flg Gr. 5
6	STD541437	Nut, Crownlock 3/8-16 Unc	18	19171912	Washer 17/32 x 1-3/16 x 12 Ga.
7	124181X	Spring, Seat Cprsn	19	166369	Knob, Seat
8	150176	Bolt 5/16-18 Unc x 3/4 w/Sems	20	124238X	Cap, Spring Seat
10	155925	Pan, Seat	21	153236	Bolt, Shoulder 5/16-18
12	121246X	Bracket, Mounting Switch	22	STD541431	Nut, Crownlock 5/16-18 Unc

NOTE: All component dimensions given in U.S. inches
1 inch = 25.4 mm

REPAIR PARTS

TRACTOR - - MODEL NUMBER 917.259860

DECALS

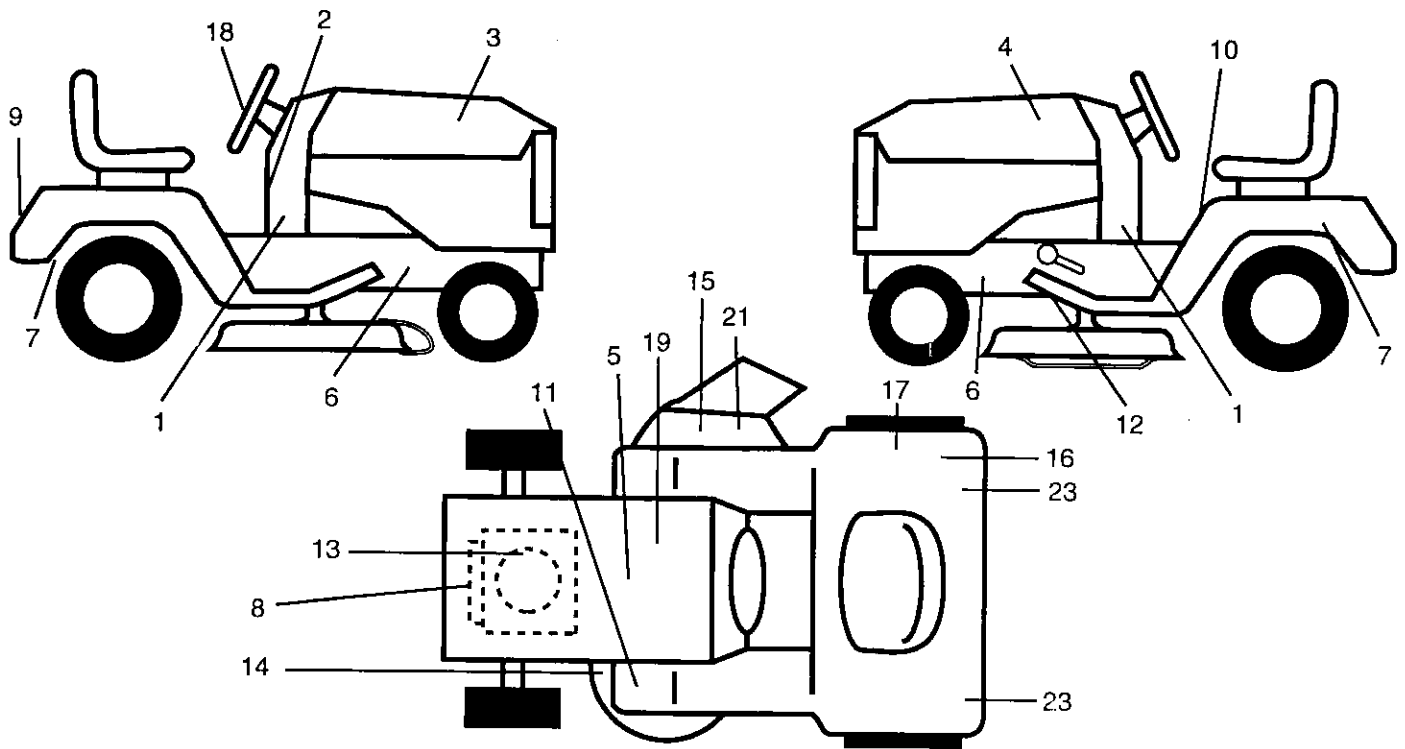

KEY NO.	PART NO.	DESCRIPTION
1	163265	Decal, Dash Panel
2	164487	Decal, Dash Ammeter
3	163916	Decal, Hood, Craftsman, RH
4	163917	Decal, Hood, Craftsman, LH
5	145005	Decal, Battery DNGR/PSN
6	159736	Decal, Hot Muffler
7	163210	Decal, Fender
8	164757	Decal, Engine
9	163204	Decal, Fender, Craftsman
10	145498	Decal, Read Owner's Manual
11	159737	Decal, Clutch/Brake
12	146047	Decal, V-Belt Drive Schematic
13	164884	Decal, Blower Housing
14	160397	Decal, V-Belt Schematic

KEY NO.	PART NO.	DESCRIPTION
15	145494	Decal, International Cutfinger
16	126187X	Decal, Certification
17	145437	Decal, Europe Stand CE
18	164065	Decal, Insert Strg
19	138047	Decal, Battery
21	166887	Decal, Mower EZ3
23	106202X	Reflector, Taillight
--	138311	Decal, Handle Lft Height Adjust (Lift Handle)
--	157199	Pad, Footrest
--	162598	Decal, Drawbar Load Limit
--	168676	Manual, Oper (Euro)
--	168677	Manual, Oper (Scandi)
--	168678	Manual, Parts

WHEELS AND TIRES

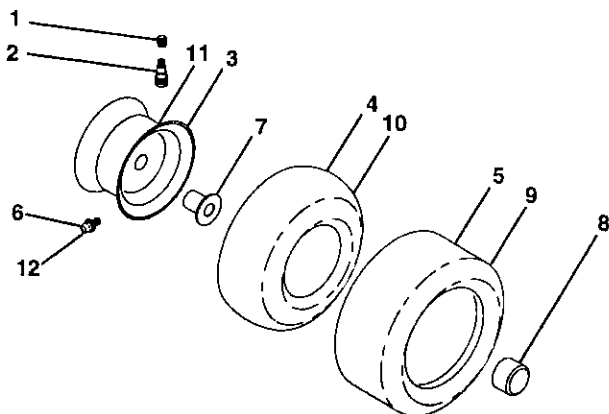

KEY NO.	PART NO.	DESCRIPTION
1	59192	Cap, Valve, Tire
2	65139	Stem, Valve
3	106229X427	Rim Assembly, Front
11	106277X427	Rim Assembly, Rear
4	8134H	Tube, Front (Service Item Only)
10	7154J	Tube, Rear (Service Item Only)
5	106230X	Tire, Front
9	105588X	Tire, Rear
6	278H	Fitting, Grease (Front Wheel Only)
12	6856M	Fitting, Grease
7	9040H	Bearing, Flange (Front Wheel Only)
8	104757X	Cap, Axle (Front Wheel Only)
--	144334	Sealant, Tire (10 oz. Tube)

NOTE: All component dimensions given in U.S. inches
1 inch = 25.4 mm

REPAIR PARTS

TRACTOR - - MODEL NUMBER 917.259860

MOWER LIFT

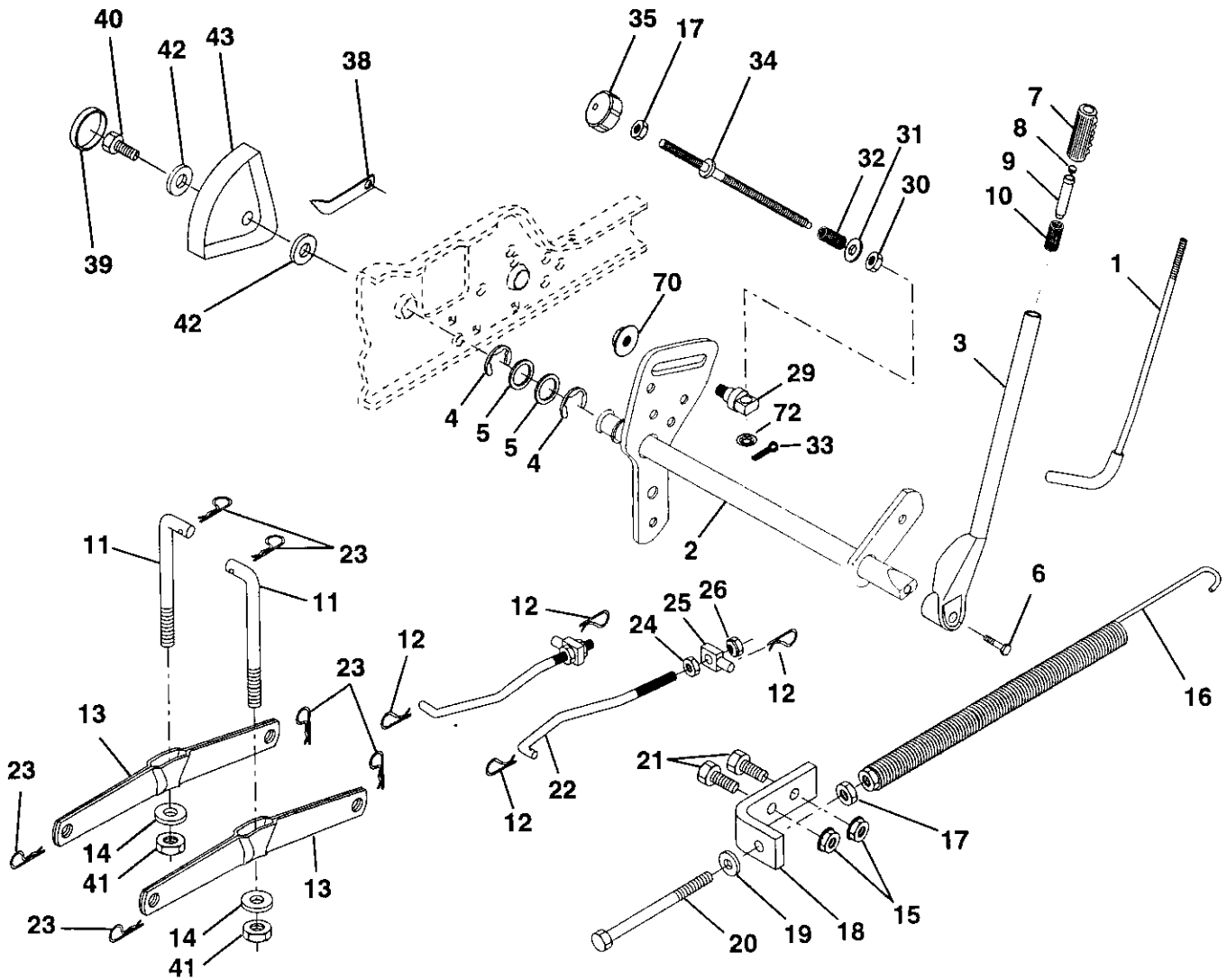

REPAIR PARTS

TRACTOR - - MODEL NUMBER 917.259860

MOWER LIFT

KEY NO.	PART NO.	DESCRIPTION
1	121006X	Rod Asm., Lever
2	159187	Shaft Asm., Lift Vgt
3	159189	Lever Asm., Lift Rh
4	12000022	E-Ring Truarc #5133-87
5	19292016	Washer 29/32 x 1-1/4 x 16 Ga.
6	74780624	Bolt, Fin Hex 3/8-16 x 1-1/2
7	125631X	Grip, Handle Fluted
8	122365X	Button, Plunger
9	122364X	Plunger, Button
10	2876H	Spring 2-1/8"
11	146704	Link Lift
12	163552	Retainer, Spring
13	139868	Arm, Suspension Vgt
14	140302	Bearing
15	STD541437	Nut, Crownlock 3/8-16 Unc
16	674A247	Spring Asm., Assist Lift
17	STD541237	Nut, Hex Jam 3/8-16 Unc
18	143363	Bracket, Spring Assist
19	STD551037	Washer 13/32 x 13/16 x 16 Ga.
20	5328J	Bolt, Adjust Spring Assist
21	STD523710	Bolt, Fin Hex 3/8-16 x 1
22	127218	Link, Front
23	STD624008	Retainer, Spring
24	73350800	Nut, Jam Hex 1/2-13 Unc
25	130171	Trunnion
26	73680800	Nut, Crownlock 1/2-13 Unc
29	150233	Trunnion, Infin Height
30	110807X	Nut, Special
31	19131016	Washer 13/32 x 5/8 x 16 Ga.
32	137150	Spring, Compression Inf Hgt
33	STD560907	Pin, Cotter 3/32 x 1/2
34	137167	Rod, Adj Lift
35	138057	Knob, Inf 3/8-16 Unc
38	155097	Pointer, Height Indicator
39	123935X	Plug, Hole
40	17490512	Screw Hex Wsh 5/16-18 x 3/4
41	73540600	Nut, Crownlock 3/8-24
42	19112410	Washer 11/32 x 1-1/2 x 10 Ga.
43	123934X	Scale, Indicator Height
70	145212	Nut Hex Flange Lock
72	110452X	Nut Push Phos & Oil

NOTE: All component dimensions given in U. S. inches
1 inch = 25.4 mm

REPAIR PARTS

TRACTOR - - MODEL NUMBER 917.259860

MOWER DECK

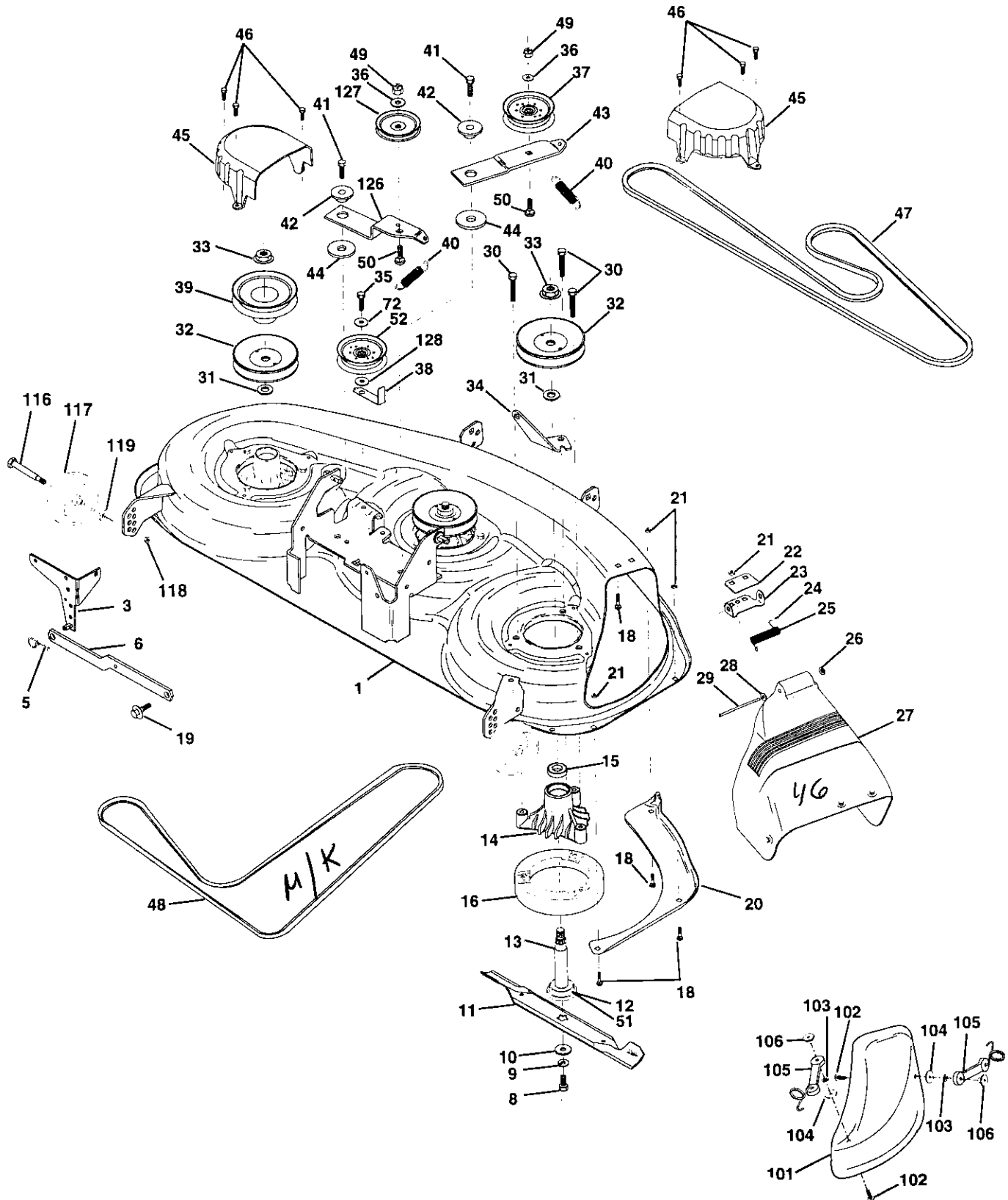

REPAIR PARTS

TRACTOR - - MODEL NUMBER 917.259860

MOWER DECK

KEY NO.	PART NO.	DESCRIPTION	KEY NO.	PART NO.	DESCRIPTION
1	164210	Deck Weldment	39	144917	Pulley, Idler, Driven
3	138457	Bracket Asm., Sway Bar	40	137273	Spring, Secondary 44/46/50 Vent
5	STD624008	Retainer Spring	41	17490620	Screw, Thdroll 3/8-16 x 1-1/4 Tytt
6	130832	Arm, Suspension, Rear (Sway Bar)	42	122052X	Spacer, Retainer
8	850857	Bolt, Patched 3/8-24 x 1-1/4 Gr. 8	43	144949	Arm, Idler Secondary
9	STD551137	Washer, Lock Hvy., Unplated 3/8	44	133943	Washer, Hardened
10	140296	Washer, Hard Blade, Mower Vented	45	145059	Cover, Mandrel Deck
11	163819	Blade	46	137729	Screw, Thdroll. 1/4-20 x 5/8
12	129895	Bearing, Ball, Mandrel #6204	47	144959	V-Belt, Mower, Secondary
13	137553	Shaft Asm. w/Lower Bearing (Includes Key No. 12)	48	148763	V-Belt, Mower, Primary
14	137152	Housing, Mandrel	49	STD541437	Nut, Crownlock 3/8-16 UNC
15	110485X	Bearing, Ball, Mandrel	50	72110612	Bolt, Carriage 3/8-16 x 1-1/2 Gr. 5
16	140329	Stripper, Mower Round	51	153390	Washer Felt
18	STD533106	Bolt, Carriage 5/16-18 x 5/8	52	156493	Pulley Idler 46" Prim. Drive
19	132827	Bolt, Hex Head, Shoulder 5/16-18	72	19131616	Washer 13/32 x 1 x 16 Ga.
20	145055	Baffle, Vortex Mower 46"	101	145579	Cover, Mulching
21	STD541431	Nut, Crownlock 5/16-18 UNC	102	71161010	Screw
22	134753	Stiffener, Bracket	103	STD551110	Washer, Lock #10
23	131267	Bracket, Deflector	104	19061216	Washer
24	105304X	Cap, Sleeve	105	160793	Latch Asm. Bagger
25	149287	Spring, Torsion, Deflector	106	2029J	Nut, Weld
26	110452X	Nut, Push	116	137644	Bolt, Shoulder
27	157788	Shield, Deflector Mower	117	133957	Gauge Wheel
28	19111016	Washer 11/32 x 5/8 x 16 Ga.	118	73930600	Nut, Centerlock 3/8-16 UNC
29	131491	Rod, Hinge	119	19121414	Washer 3/8 x 7/8 x 14 Ga.
30	157722	Screw, Thd Rolling Washer Head	126	144948	Arm, Idler, Primary Deck 46"
31	129963	Washer, Spacer Mower Vented	127	146763	Pulley, Idler, V-Groove Dim. 4.25
32	153531	Pulley, Mandrel	128	19132203	Washer 13/32 x 1-3/8 x 3 Ga.
33	137266	Nut, Flg. Top Lock Cntr. 9/16	--	166222	Mower Service 46" (Standard Deck - Order separately mulching components Key Nos. 101-106)
34	144945	Anchor, Spring Deck 46"	--	143651	Mandrel Asm 44/50 Service (Includes Key Nos. 8-10, 12-15, 31 and 33)
35	17490628	Screw, Thdroll 3/8-16 x 1-3/4 Tytt			
36	STD551037	Washer 13/32 x 13/16 x 16 Ga.			
37	131494	Pulley, Idler, Flat			
38	156086	Keeper, Belt, Idler			

NOTE: All component dimensions given in U.S. inches
1 inch = 25.4 mm

REPAIR PARTS

TRACTOR -- MODEL NUMBER 917.259860

TRANSAXLE

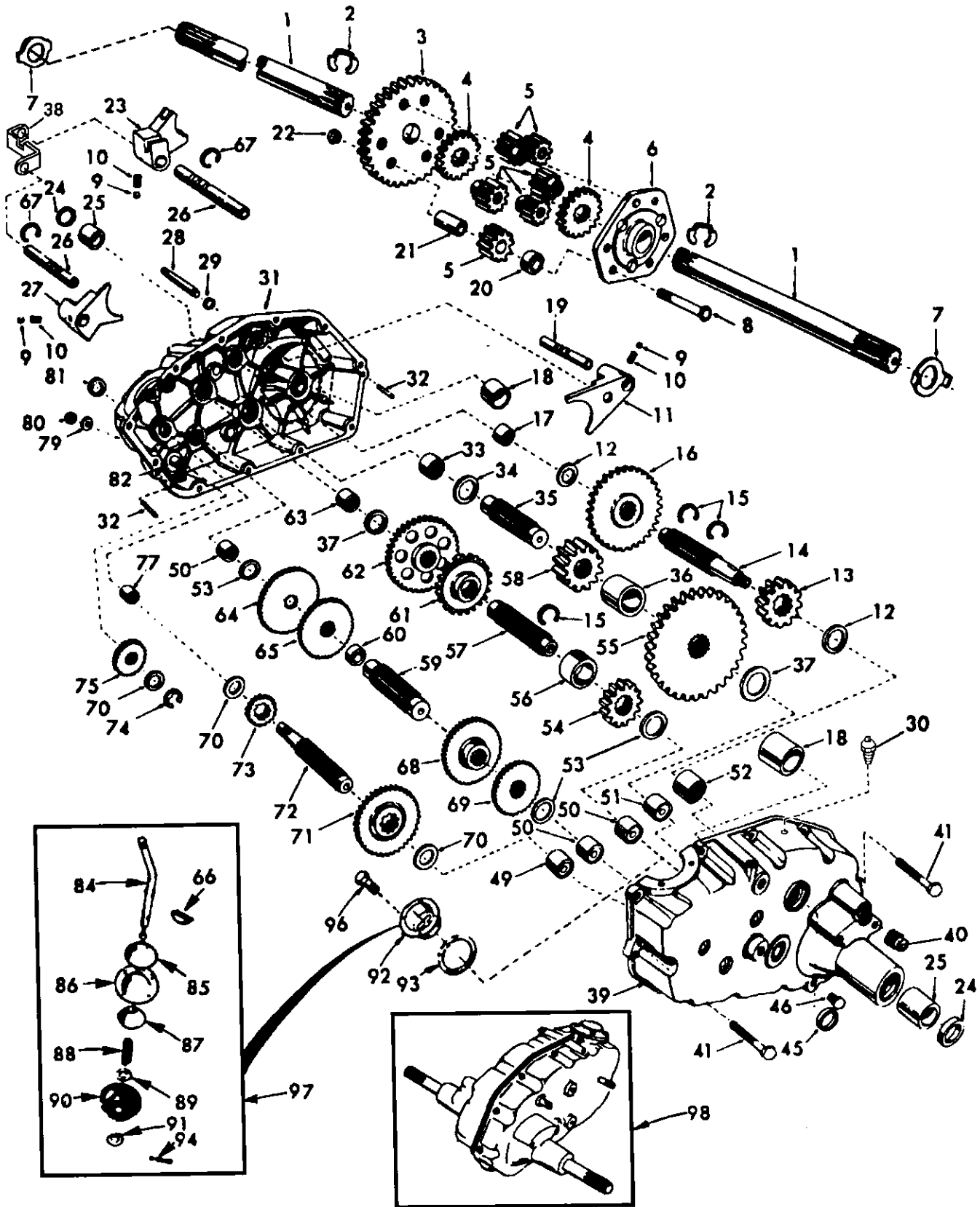

REPAIR PARTS

TRACTOR - - MODEL NUMBER 917.259860

TRANSAXLE

KEY NO.	PART NO.	DESCRIPTION	KEY NO.	PART NO.	DESCRIPTION
1	4197R	Axle Shaft	52	8119M	Needle Bearing
2	12000034	Retaining Ring	53	4220R	Thrust Bearing Race
3	4199R	Final Drive Gear	54	4209R	3rd Reduction Pinion, Low
4	4216R	Differential Gear	55	4213R	4th Reduction Gear
5	4215R	Differential Pinion	56	4442R	3rd Reduction Pinion Spacer
6	4217R	Differential Carrier	57	4195R	2nd Reduction Gear Shaft
7	6256H	Axle Thrust Washer	58	4214R	Final Drive Pinion
8	74020652	Bolt, Hex Head 3/8-24 x 3-1/4 (1" Thread Length)	59	4194R	1st Reduction Gear Shaft
9	7392M	Steel Ball	60	7528R	1st Reduction Shaft Spacer
10	137261	Spring Shift Fork Detent	61	4208R	3rd Reduction Pinion Hlgh
11	4985R	Shift Fork, High-Low Range	62	4207R	2nd Reduction Gear
12	6266H	Thrust Bearing Race	63	7398H	Needle Bearing
13	4212R	4th Reduction Pinion	64	4203R	Low Speed Gear and 2nd Reduction Pinion Cluster
14	137125	Shaft, Brake	65	4204R	Reverse Gear
15	6276H	Snap Ring, Crescent Type	66	2898J	Key, Hi-Pro 1/8 x 17/32
16	633A63	High-Low Range Gears	67	12000033	Klip Ring
17	8118M	Needle Bearing	68	4205R	Intermediate Speed Gear
18	8740H1	Sintered Iron Bearing	69	4206R	High Speed Gear
19	122238X	Shift Fork Shaft, High-Low Range	70	1370H	Thrust Bearing Race
20	4218R	Differential Pinion Spacer	71	633A69	Intermediate and High Speed Cluster Pinions
21	6252H1	Differential Pinion Bushing	72	139120	Input Shaft
22	7810H	Gripco Centerlock Nut 3/8-24	73	4201R	Low Speed Pinion
23	6262H	Shift Fork, R.H.	74	12000008	E-Ring
24	7393R	Oil Seal	75	1153R	Reverse Idler Gear
25	992R1	Sintered Iron Bearing	77	6803J	Needle Bearing
26	139111	Shift Fork Shaft	79	1167R	Sealing Washer
27	4986R	Shift Fork, L.H.	80	73360700	Nut, Hex, Jam 7/16-20
28	122254X	Shift Shaft, High-Low Range	81	6270H	Oil Seal
29	6269H	Oil Seal	82	136984	Reverse Idler Shaft
30	5855H	Pressure Relief Valve	84	5384J	Gearshift Lever, Bent
31	139538	Gearcase, Reverse Idler Shaft and Bearings, R.H. (Includes Key No.'s 17, 18, 25, 33, 50, 63, 77 and 82)	85	2978J	Gearshift Cap
32	6277H	Dowel Pin	86	633A85	Gearshift Ball Cover and Pin
33	4225R	Needle Bearing	87	8739H1	Shift Lever Guide Ball, Keyed
34	7396H	Thrust Bearing Race	88	4924H	Spring
35	4198R	4th Reduction Gear Shaft	89	19151516	Washer 15/32 x 15/16 x 16 Gauge
36	4200R	4th Reduction Gear Spacer	90	110542X	Shift Mechanism Seal
37	7395H	Thrust Bearing Race	91	19181511	Washer 9/16 x 15/16 x 12 Gauge
38	160789	Gate, Lower, Shift	92	75J	Gearshift Gate and Reinforcement
39	139536	Gearcase and Bearings, L.H. (Includes Key Numbers 18, 25, 49, 50 (2), 51 and 52)	93	6274H	Shift Ball Cover Gasket
40	13320400	Pipe Plug 1/2-14 N.P.T.	94	76020412	Cotter Pin 1/8 x 3/4
41	17580520	Bolt, Hex 5/16-18 UNC x 1-1/4	96	159783	Screw Hex Washer Head Machine
45	6271H	Oil Seal	97	633A109	Gearshift Lever Assembly
46	13060200	Pipe Plug 1/4-18 N.P.T.	98	161823	Transaxle, 6 Speed, Complete Assembly
49	4895H	Needle Bearing			
50	4222R	Needle Bearing			
51	1529R	Needle Bearing			

NOTE: All component dimensions given in U.S. inches
1 inch = 25.4 mm

REPAIR PARTS

TRACTOR - - MODEL NUMBER 917.259860

KOHLER ENGINE - MODEL NUMBER CV20S, TYPE NUMBER 65544

CYLINDER HEAD/VALVE/BREATHER

KEY NO.	PART NO.	DESCRIPTION
1	24-318-21	Head Assembly, #1 Cylinder
2	24-755-76	Kit, Valve Cover, Breather (Includes Key #3, 29 thru 30)
3	25-313-02	Grommet, Rubber
4	24-033-03	Kit, Breather Cover with Gasket (Includes Key Numbers 5 and 6)
5	24-041-23	Gasket, Breather
6	24-096-15	Cover, Breather
7	M-0645020	Screw Hex Flange M6 x 1.0 x 20 (4)
9	X-426-9	Clamp, Hose (2)
10	24-326-14	Hose, Breather
11	12-755-03	Kit, Retainer (4)
12	12-173-01	Cap, Valve Spring (4)
13	24-089-02	Spring, Valve (4)
14	235011	Retainer, Spring (4)
15	24-016-01	Valve, Exhaust, Standard Size (2)
	24-016-02	Valve, Exhaust, .25 Oversize (2)
16	24-017-01	Valve, Intake, Standard Size (2)
	24-017-02	Valve, Intake, .25 Oversize (2)
17	24-032-05	Seal, Valve Stem (2)
18	24-294-06	Fitting
19	24-326-13	Hose, Breather
20	12-351-02	Lifter, Valve (4)
21	24-411-05	Rod, Push (4)
22	24-041-08	Gasket, Cylinder Head (2)
23	24-318-25	Head Assembly, #2 Cylinder
24	24-755-66	Kit, Valve Train (Includes Key Numbers 21, 25-26)
25	25-186-01	Arm, Rocker (4)
26	24-599-01	Pivot, Rocker Arm (4)
27	M-0640034	Screw Hex Flange M6 x 1.0 x 34 (4)
28	24-755-74	Kit, Valve Cover, Plain (Includes Key Numbers 29 thru 30)
29	24-153-16	O-Ring
30	24-086-32	Screw, Shoulder (4)
31	12-086-16	Screw Hex Flange M10 x 1.5 x 90 (8)
32	24-445-01	Strap, Lifting
33	24-755-57	Kit, Breather Separator (Includes Key Numbers 34 thru 38)
34	24-112-12	Spacer
35	24-126-44	Bracket, Breather Separator
36	25-313-02	Grommet, Rubber
37	24-445-02	Strap, Breather Separator
38	M-0545016	Screw Hex Flange M5 x 0.8 x 16 (2)

CRANKCASE

KEY NO.	PART NO.	DESCRIPTION
1	24-782-05	Cylinder Block (Use Mini Block)
2	24-294-13	Fitting
3	24-067-13	Connecting Rod (Standard) (2)
	24-067-14	Connecting Rod (.25) (2)
4	12-380-17	Pin, Dowel Locating (6)
5	52-139-09	Plug, Cup
6	24-874-01	Piston with Ring Set (Standard) (2)
	24-874-02	Piston with Ring Set (.25) (2)
	24-874-03	Piston with Ring Set (.50) (2)
7	24-108-01	Ring Set (Standard) (2)
	24-108-02	Ring Set (.25) (2)
	24-108-03	Ring Set (.50) (2)
8	24-018-01	Retainer, Piston Pin (4)
9	12-422-10	Shim, Camshaft, Yellow
	12-422-09	Shim, Camshaft, Red (As Required)
	12-422-13	Shim, Camshaft, Black (As Required)
	12-422-07	Shim, Camshaft, White (As Required)
	12-422-08	Shim, Camshaft, Blue (As Required)
	12-422-11	Shim, Camshaft, Green (As Required)
	12-422-12	Shim, Camshaft, Grey (As Required)
10	24-010-03	Camshaft
11	24-144-01	Shaft, Governor Cross
12	M0631005	Washer, Plain 6mm
13	12-032-01	Seal, Governor Cross Shaft
14	X-25-102	Washer, Plain 1/4
15	12-380-04	Pin, Hitch
16	M-0545010	Screw, Hex Flange M5 x 0.8 x 10 (2)
17	24-018-04	Retainer, Reed (2)
18	24-402-05	Reed, Breather (2)
19	24-032-01	Seal, Oil, Front
20	12-153-01	O-Ring, Lower Oil Fill Tube
21	12-123-04	Tube, Oil Fill
22	24-126-19	Bracket, Oil Fill Tube
23	M-0545016	Screw, Hex Flange M5 x 0.8 x 16
24	12-153-02	O-Ring, upper Oil Fill Tube
25	24-038-04	Dipstick Assembly (Includes 26-27)
26	25-755-13	Kit, Oil Fill Cap (Includes 27)
27	12-153-03	O-Ring, Dipstick

NOTE: All component dimensions given in U.S. inches
1 inch = 25.4 mm

REPAIR PARTS

TRACTOR -- MODEL NUMBER 917.259860

KOHLER ENGINE - MODEL NUMBER CV20S, TYPE NUMBER 65544

IGNITION / ELECTRICAL

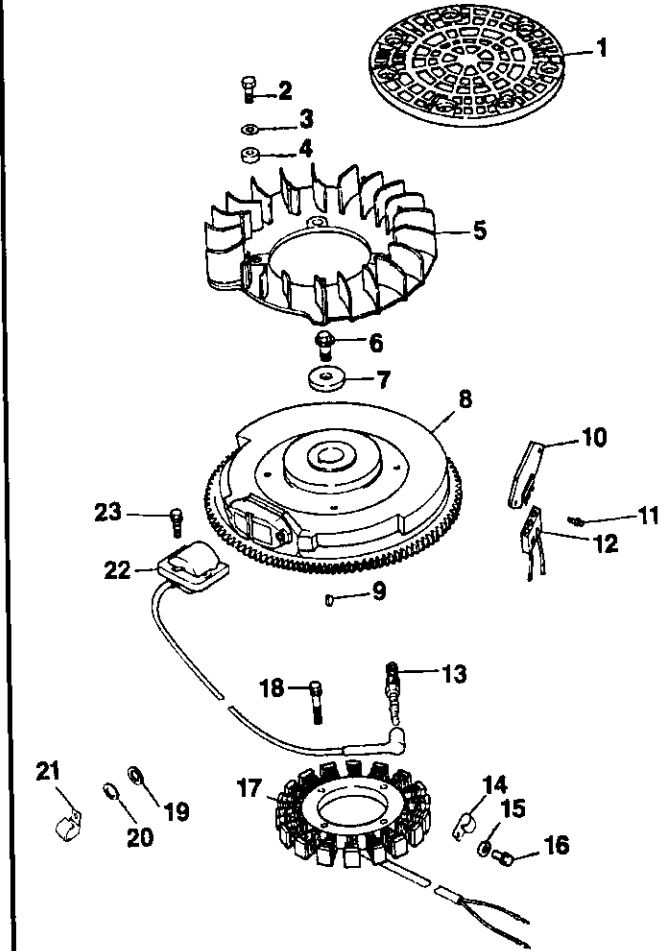

BLOWER HOUSING AND BAFFLES

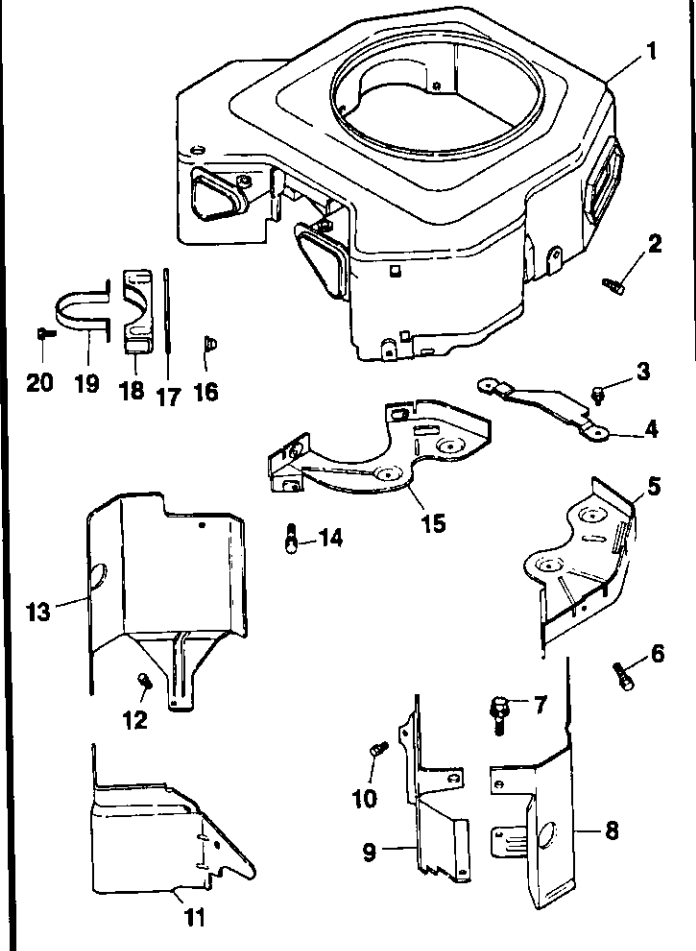

AIR INTAKE

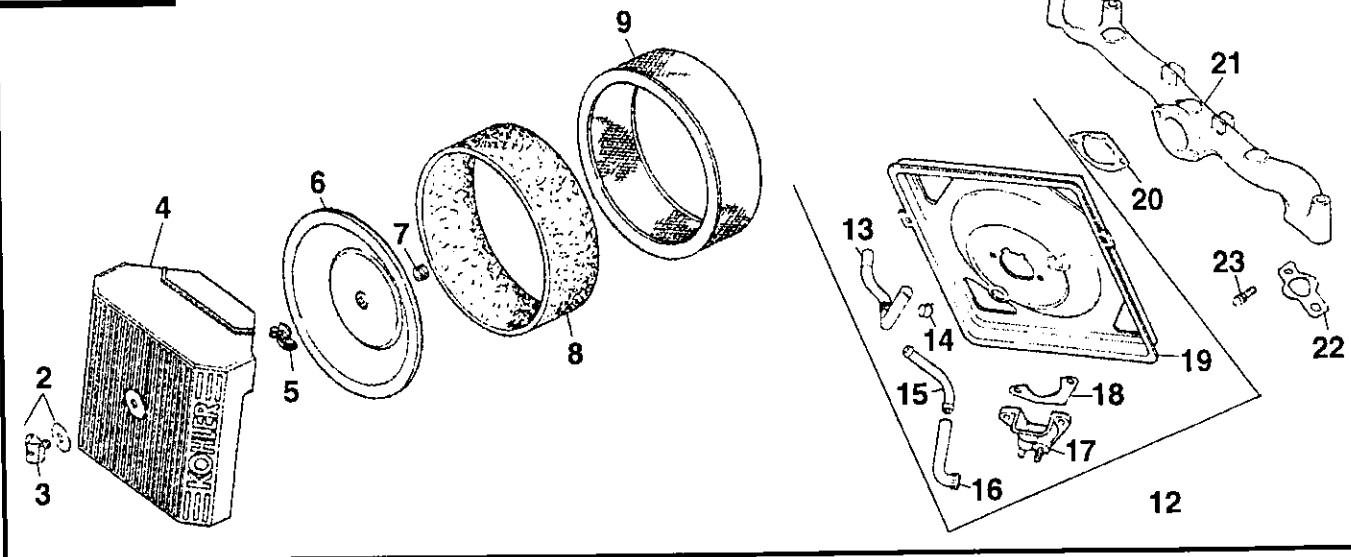

REPAIR PARTS

TRACTOR - - MODEL NUMBER 917.259860

KOHLER ENGINE - MODEL NUMBER CV20S, TYPE NUMBER 65544

IGNITION/ELECTRICAL

KEY NO.	PART NO.	DESCRIPTION
1	54-755-15	Kit, Grass, Screen (Includes 1,2,3,4, 241138 Decal)
2	M-0403025	Screw, Hex, Cap M4 x 0.7 x 24 (4)
3	X-25-92	Washer, Plain 3/16 (4)
4	24-112-04	Spacer, Fan (4)
5	24-157-03	Fan
6	M-0639016	Screw Hex, Flange M6 x 1.0 x 16 (4)
7	12-112-01	Spacer, Fan (4)
8	24-025-04	Flywheel Assembly
9	X-42-15	Key
10	25-403-03	Rectifier-Regulator
11	24-086-18	Screw, Phillips (2) Hd. 11-16 x 7/8
12	236602	Connector, Rectifier-Regulator, 3 Contact
13	28-132-01	Spark Plug (2)
14	48-154-02	Clip, Cable
15	12-468-03	Washer, Plain 3/8
16	12-086-14	Screw, Hex, Flange M10 x 1.5 x 46
17	54-755-09	Kit, 15 Amp Stator (Inc. 2412671 Bracket)
18	M-0548025	Screw, Hex, Cap M5 x 0.8 x 25 (2)
19	X-25-63	Washer, Plain 1/4
20	X-25-92	Washer, Plain 3/8 (2)
21	235173	Clip, Cable
22	24-584-14	Module, Ignition (2)
23	SM-0545020	Screw, Hex, Flange M5 x 0.8 x 20 (4)
NOT ILLUSTRATED		
--	24-126-71	Bracket, Stator, Wire -
--	24-176-12	Harness, Wire
--	25-518-28	Lead, Black (4", 18 Gauge, Insulated Grip Barrel Eyelets)
--	24-113-18	Decal, Grass Screen
--	x-22-11	Washer, Lock, 1/4

BLOWER HOUSING & BAFFLES

KEY NO.	PART NO.	DESCRIPTION
1	24-027-20	Housing, Blower
2	M-0545016	Screw, Hex Flange M5 x 0.8 x 16 (3)
3	M-0645016	Screw, Hex Flange M6 x 1.0 x 16 (4)
5	24-146-02	Plate, Backing, # 2 Side
6	M-0545020	Screw, Hex Flange M5 x 0.8 x 20 (2)
7	M-0551016	Screw, Hex Flange M5 x 0.8 x 16
8	24-063-40	Baffle, Cylinder Barrel, # 2 Side
9	24-063-41	Baffle, Cylinder Barrel, # 1 Side
10	M-0545010	Screw, Hex Flange M5 x 0.8 x 10 (2)
11	24-063-23	Baffle, Valley, # 1 Side
12	M-0545016	Screw, Hex Flange M5 x 0.8 x 16 (2)
13	24-063-30	Baffle, Cylinder Barrel, # 1 Side
14	M-0645016	Screw, Hex Flange M6 x 1.0 x 16 (2)
15	24-146-08	Plate, Backing, # 1 Side
16	24-100-02	Nut, Plastic (2)
17	24-112-12	Spacer
18	24-126-44	Bracket, Breather Separator
19	24-445-02	Strap, Breather
20	24-086-18	Screw, Phillips Hd. 11-16 x 7/8

NOT ILLUSTRATED

--	24-100-01	Nut, Plastic (3) (Included with Blower Housing)
--	24-100-02	Nut, Plastic (2) (Included with Blower Housing)
--	25-139-16	Plug, Button 9/16 (Included with Blower Housing)
--	24-113-12	Decal, Horsepower

AIR INTAKE

KEY NO.	PART NO.	DESCRIPTION
2	54-755-01	Kit, Knob w/Gasket (Includes Key Number 3 And 2415315 Seal AC Knob)
3	25-341-03	Knob, Cover
4	24-096-24	Cover, Air Cleaner
5	12-100-01	Wing Nut
6	24-096-01	Cover, Inner Air Cleaner
7	24-032-03	Seal, Air Intake
8	24-083-02	Element, Pre-Cleaner
9	47-083-03	Element, Air Cleaner
12	24-755-86	Kit, Air Cleaner Base (Includes Key Numbers 13-20)
13	24-326-13	Hose, Breather
14	X-426-9	Clamp, Hose (2)
15	24-294-06	Fitting
16	24-326-14	Hose, Breather
17	24-109-06	Cup, Fuel Spitback
18	24-041-13	Gasket, Fuel Spitback Cup
19	24-094-14	Base, Air Cleaner
20	24-041-14	Gasket, Air Cleaner Base
21	24-164-06	Manifold, Intake
22	24-041-01	Gasket, Intake Manifold (2)
23	M-0651055	Screw, Hex Flange M6 x 1.0 x 55 (4)
NOT ILLUSTRATED		
--	12-113-53	Decal, Air Cleaner

NOTE: All component dimensions given in U.S. inches
1 inch = 25.4 mm

REPAIR PARTS

TRACTOR - - MODEL NUMBER 917.259860

KOHLER ENGINE - MODEL NUMBER CV20S, TYPE NUMBER 65544

STARTING SYSTEM

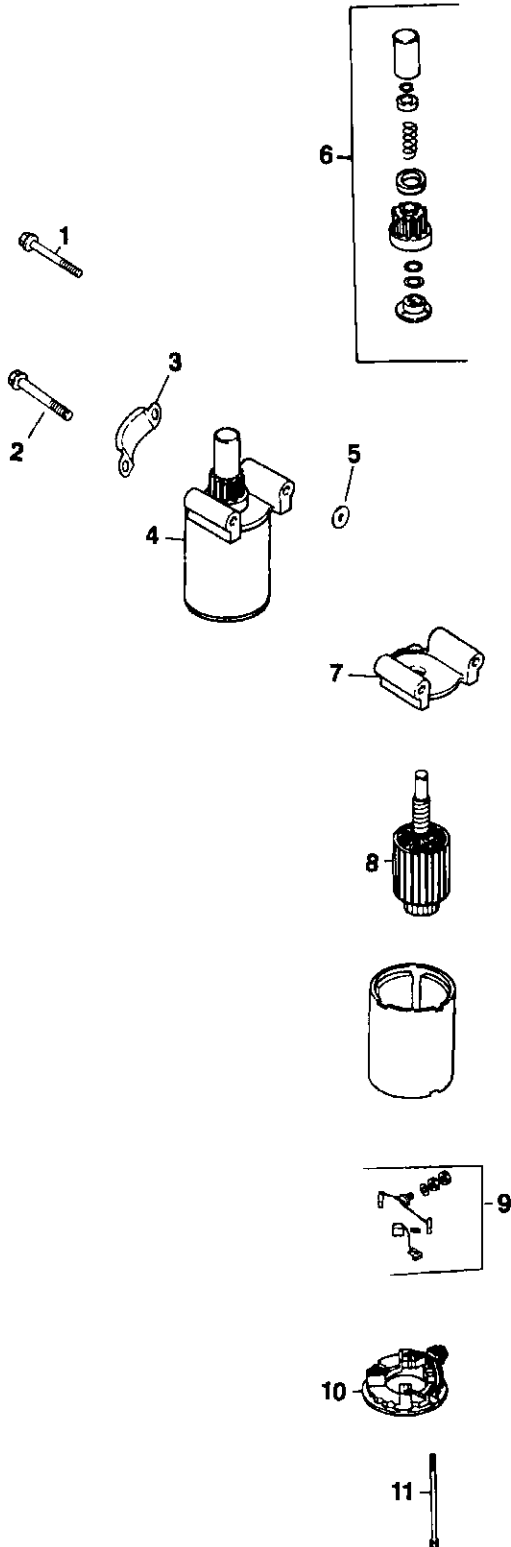

ENGINE CONTROLS

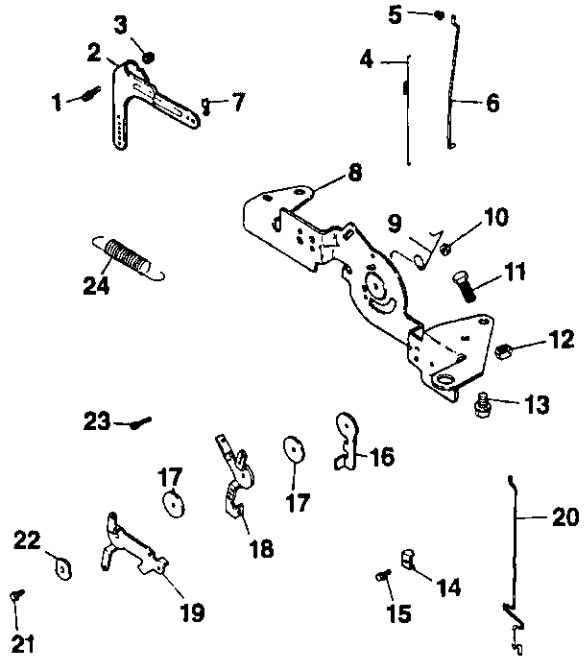

OIL PAN / LUBRICATION

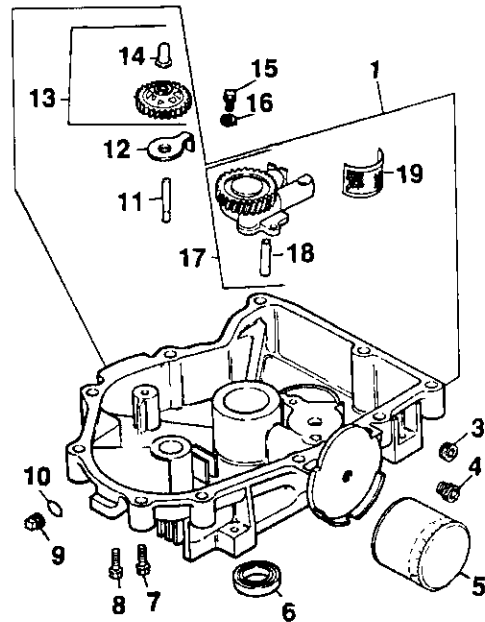

REPAIR PARTS

TRACTOR - - MODEL NUMBER 917.259860

KOHLER ENGINE - MODEL NUMBER CV20S, TYPE NUMBER 65544

STARTING SYSTEM

KEY PART NO. NO.	DESCRIPTION
1 M-0839070	Screw, Hex Flange M8 x 1.25 x 70
2 M-0839080	Screw, Hex Flange M8 x 1.25 x 80
3 24-096-05	Cover, Pinion
4 25-098-05	Starter Assembly (Includes 6-11)
5 12-468-01	Washer, Plain 11/32 (3)
6 12-755-54	Kit, Drive End
7 12-227-06	Cap, Drive End
8 12-170-05	Armature
9 12-221-01	Kit, Brush and Spring
10 12-227-13	Cap, Commutator End
11 12-211-01	Bolt, Thru (2)

OIL PAN/LUBRICATION

KEY PART NO. NO.	DESCRIPTION
1 24-199-07	Oil Pan Assembly (Includes Key Numbers 11-14 and 11-19)
3 X-75-32	Plug, Hex, Countersunk, 3/8
4 24-136-01	Nipple, Oil Filter
5 12-050-01	Filter, Oil
6 52-032-08	Seal, Oil (PTO End)
7 24-086-17	Screw, Hex Flange M8 x 1.25 x 45
8 24-086-16	Screw, Hex Flange M8x1.25x45 (9)
9 X-75-10	Plug, Solid, Square Head, 3/8
10 24-153-08	O-Ring
11 12-144-02	Shaft, Governor Gear
12 52-448-02	Tab, Locking
13 24-043-12	Kit, Governor Gear with Pin (Includes Key Number 14)
14 12-380-01	Pin, Governor Regulating
15 M-0645025	Screw, Hex Flange M6 x 1.0 x 25 (2)
16 M-0631005	Washer, Plain 6mm (2)
17 24-393-08	Oil Pump Assembly (Includes 17)
18 24-123-05	Tube, Oil Pickup
19 24-162-26	Screen, Oil

NOT ILLUSTRATED

-- 25-099-24	Switch, Pressure
-- 25-113-05	Decal, Oil Sentry

ENGINE CONTROLS

KEY PART NO. NO.	DESCRIPTION
1 SM-0642025	Screw, Hex Flange M6 x 1.0 x 25
2 24-090-14	Lever, Governor
3 M-0641060	Nut, Hex Flange M6 x 1.0
4 24-089-01	Spring, Linkage
5 25-158-08	Bushing, Linkage Retaining
6 24-079-04	Linkage, Throttle
7 25-158-11	Bushing, Throttle Linkage
8 24-126-56	Bracket, Control
9 24-089-03	Spring, Choke Return
10 M-0547050	Locknut, Hex M5 x 0.8
11 M-0545016	Screw, Hex Flange M5 x 0.8 x 16
12 M-0446030	Nut, Hex M4 x 0.7
13 M-0645016	Screw, Hex Flange M6x1.0 x 16 (4)
14 12-237-01	Clamp, Cable (2)
15 M-0545016	Screw, Hex Flange M5x0.8 x 16 (2)
16 24-090-07	Lever, Throttle Actuator
17 24-468-01	Washer, Plain 5.5mm (3)
18 24-090-13	Lever, Throttle Control
19 24-090-05	Lever, Choke
20 24-079-05	Linkage, Choke
21 M-0545020	Screw, Hex Flange M5 x 0.8 x 20
22 41-468-03	Washer, Spring 1/4
23 M-0403025	Screw, Hex Cap M4 x 0.7 x 24
24 24-089-18	Spring, Governor 25

NOT ILLUSTRATED

-- 24-089-38	Spring, Throttle, Limiter
--------------	---------------------------

NOTE: All component dimensions given in U.S. inches
1 inch = 25.4 mm

REPAIR PARTS

TRACTOR - - MODEL NUMBER 917.259860

KOHLER ENGINE - MODEL NUMBER CV20S, TYPE NUMBER 65544

CRANKSHAFT

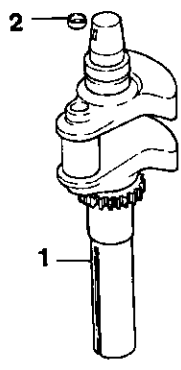

EXHAUST

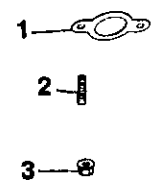

FUEL SYSTEM

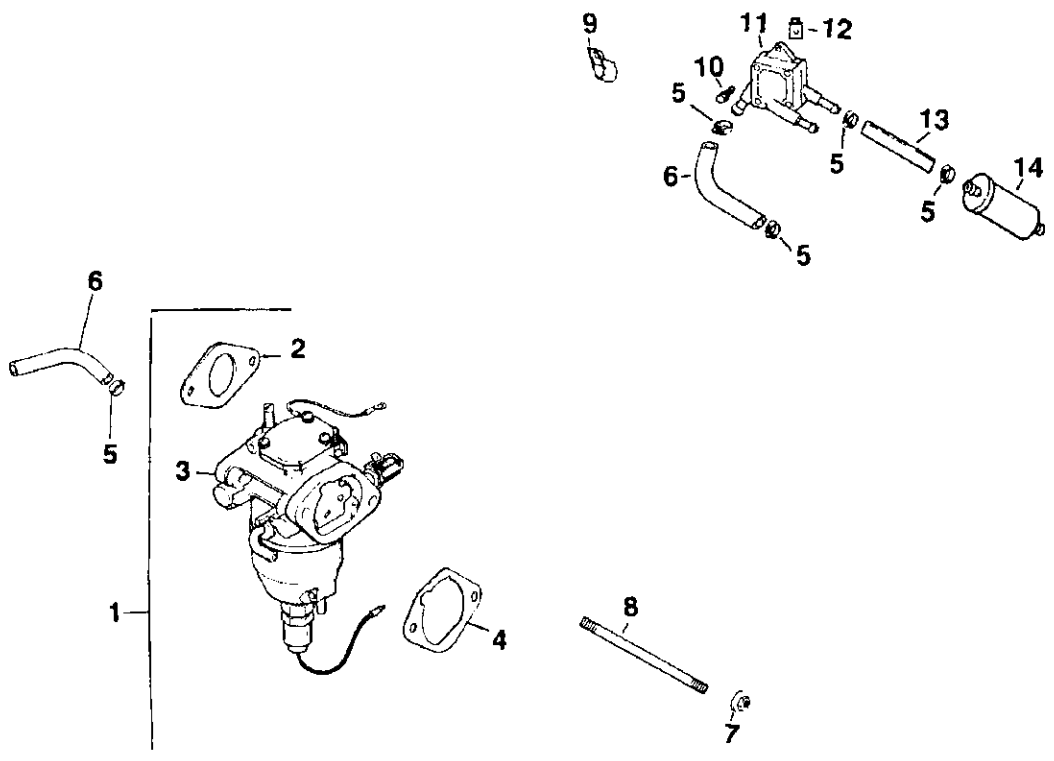

REPAIR PARTS

TRACTOR - - MODEL NUMBER 917.259860

KOHLER ENGINE - MODEL NUMBER CV20S, TYPE NUMBER 65544

FUEL SYSTEM

KEY PART NO. NO.	DESCRIPTION
1 24-853-25	Kit, Carburetor with Gasket (Includes Key Numbers 2 thru 4)
2 24-041-15	Gasket, Carburetor
3 24-053-25	Carburetor Assembly (For Information Only, Not Available Separately) (Kits listed in Not Illustrated)
4 24-041-14	Gasket, Air Cleaner Base
5 X-426-9	Clamp, Hose (6)
6 24-353-03	Line, Fuel, 10-5/8" (2)
7 M-064106	Nut Hex, Flange M6 x 1.0 (2)
8 M-06290950	Stud M6 x 1.0 x 95 (2)
9 47-154-01	Clip, Cable
10 24-086-12	Screw, Hex Cap Head M6x1.7x18 (2)
11 24-393-04	Pump, Fuel, Pulse
12 24-100-01	Nut, Plastic (2)
13 25-353-03	Line, Fuel, 13-1/2"
14 25-050-03	Filter, Fuel

NOT ILLUSTRATED

-- 24-757-18	Kit Overhaul, w/Gaskets
-- 24-757-19	Kit, Carb Repair, w/Gaskets
-- 24-757-20	Kit, Gasket, w/Gaskets
-- 24-757-22	Kit, Solenoid, w/Gaskets

CRANKSHAFT

KEY PART NO. NO.	DESCRIPTION
1 24-014-72	Crankshaft
2 52-139-09	Plug, Cup

EXHAUST

KEY PART NO. NO.	DESCRIPTION
1 24-041-02	Gasket, Exhaust (2)
2 25-072-04	Stud M8 x 1.25 x 33 (4)
3 M-0841080	Nut, Hex Flange M8 x 1.25 (4)

NOT ILLUSTRATED

KEY PART NO. NO.	DESCRIPTION
— 24-522-16	Short Block
-- 24-755-03	Gasket Set
— 24-782-05	Miniblock

RPM Settings: Low Speed: 1150-1650
High Speed: 3200-3400

NOTE: All component dimensions given in U.S. inches
1 inch = 25.4 mm

SERVICE NOTES
