

**REPAIR PARTS MANUAL**  
**MODEL NO. 274180**  
**Lawn Tractor**

*18.5 hp B&S 42" hydro*

*2006*

**CRAFTSMAN®**

# HOW TO USE THIS MANUAL

This manual is designed to provide the customer with a means to identify the parts on his/her tractor when ordering repair parts. The illustrations may or may not represent the actual assemblies; therefore, it is not recommended to use this manual as a guide to assemble or disassemble the tractor. Some hardware and parts are drawn larger in order to more readily identify them.

Each tractor has its own model number.

The model number for your tractor can be found on the fender under the seat.

When ordering parts, always give the following information:

- Product - "Tractor"
- Model Number - "274180"
- Part Number
- Part Description

## TABLE OF CONTENTS

<b>SCHEMATIC .....</b>	<b>3</b>
<b>ELECTRICAL.....</b>	<b>4-5</b>
<b>CHASSIS.....</b>	<b>6-7</b>
<b>DRIVE.....</b>	<b>8-9</b>
<b>STEERING .....</b>	<b>10-11</b>
<b>ENGINE.....</b>	<b>12-13</b>
<b>SEAT .....</b>	<b>14</b>
<b>DECALS.....</b>	<b>15</b>
<b>MOWER LIFT .....</b>	<b>16-17</b>
<b>MOWER DECK .....</b>	<b>18-19</b>
<b>TRANSAXLE.....</b>	<b>20-21</b>
<b>ENGINE BREAKDOWN.....</b>	<b>22-25</b>
<b>WARRANTY.....</b>	<b>24</b>

# TRACTOR- -MODEL NO. 917. 274180

## SCHEMATIC

03059\_197428

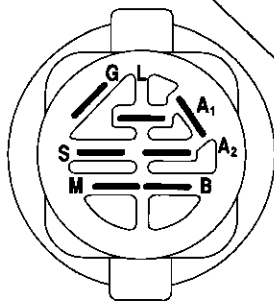
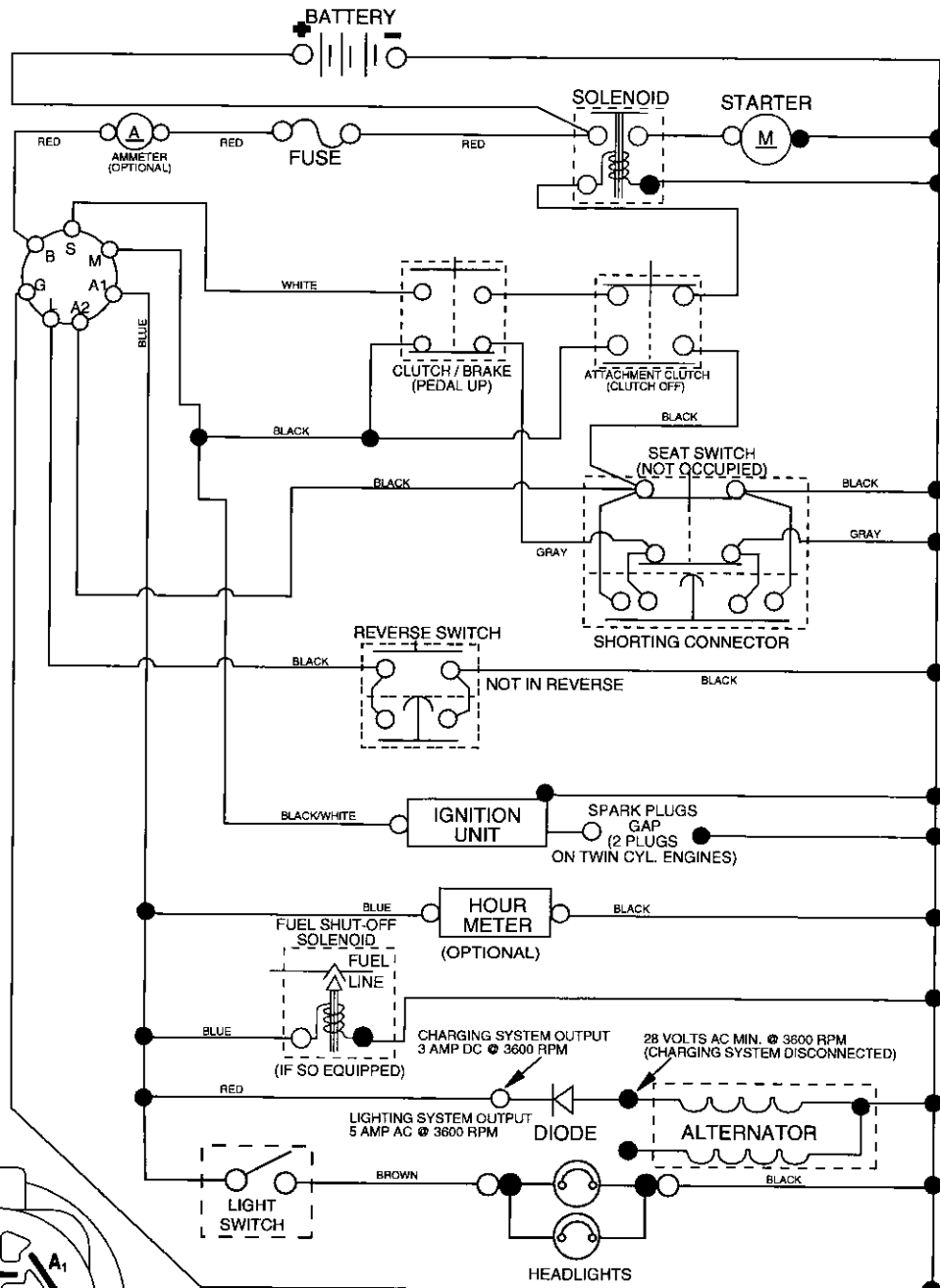

**IGNITION SWITCH**

POSITION	CIRCUIT	"MAKE"
OFF	M+G+A1	
RUN/OVERRIDE	B+A1	
RUN	B+A1	L+A2
START	B + S + A1	

03059

### NOTE

YOUR TRACTOR IS EQUIPPED WITH A SPECIAL ALTERNATOR SYSTEM. THE LIGHTS ARE NOT CONNECTED TO THE BATTERY, BUT HAVE THEIR OWN ELECTRICAL SOURCE. BECAUSE OF THIS, THE BRIGHTNESS OF THE LIGHTS WILL CHANGE WITH ENGINE SPEED. AT IDLE THE LIGHTS WILL DIM. AS THE ENGINE IS SPEEDED UP, THE LIGHTS WILL BECOME THEIR BRIGHTEST.

●  
NON-REMOVABLE CONNECTIONS

○  
REMOVABLE CONNECTIONS

### WIRING INSULATED CLIPS

**NOTE:** IF WIRING INSULATED CLIPS WERE REMOVED FOR SERVICING OF UNIT, THEY SHOULD BE REPLACED TO PROPERLY SECURE YOUR WIRING.

# REPAIR PARTS

TRACTOR- -MODEL NO. 917. 274180

## ELECTRICAL

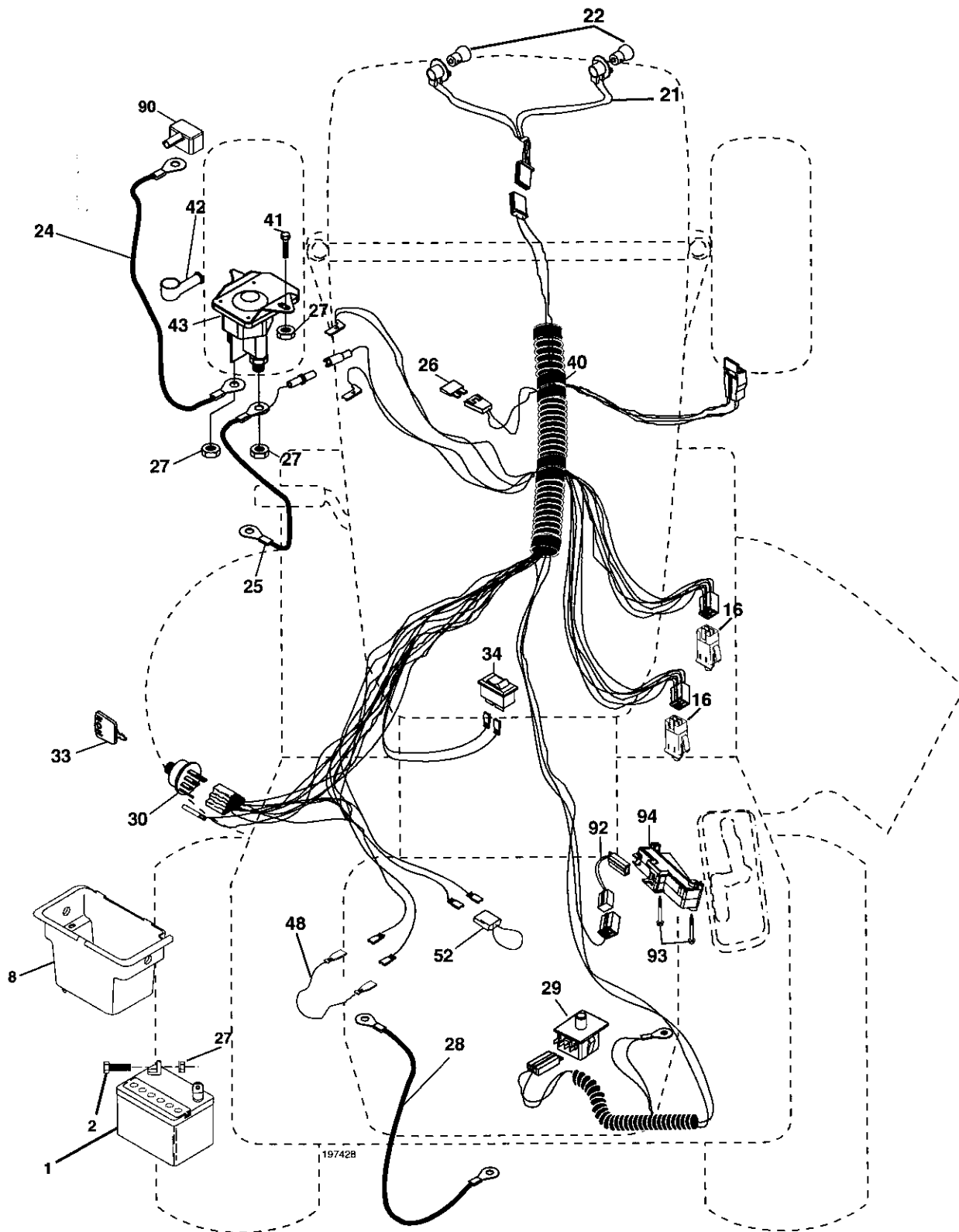

# REPAIR PARTS

## TRACTOR- -MODEL NO. 917. 274180

### ELECTRICAL

KEY NO.	PART NO.	DESCRIPTION
1	163465	Battery
2	74760412	Bolt Hex Hd 1/4-20 unc x 3/4
8	176689	Box Battery
16	176138	Switch, Interlock
21	183759	Harness Asm Light W/4152j
22	4152J	Bulb Light #1156
24	4799J	Cable Battery 6 Ga. 11" red
25	146147	Cable Battery
26	175158	Fuse
27	73510400	Nut Keps Hex 1/4-20 Unc
28	4207J	Cable Ground 6 Ga. 12" black
29	192749	Switch Seat DP w/ramps
30	193350	Switch Ign
33	140403	Key Ign
34	110712X	Switch Light
40	194728	Harness Ign
41	71110408	Bolt Blk. Fin Hex 1/4-20 unc x 1/2
42	131563	Cover Terminal Red
43	192507	Solenoid
48	140844	Adapter Ammeter
52	141940	Protection Wire Loop
90	180449	Cover Terminal
92	196615	Harness Pigtail
93	192540	Screw Plastic 10-14 x 2.0
94	191834	Module Reverse ROS

**NOTE:** All component dimensions given in U.S. inches  
1 inch = 25.4 mm

# REPAIR PARTS

TRACTOR- -MODEL NO. 917. 274180

## CHASSIS AND ENCLOSURES

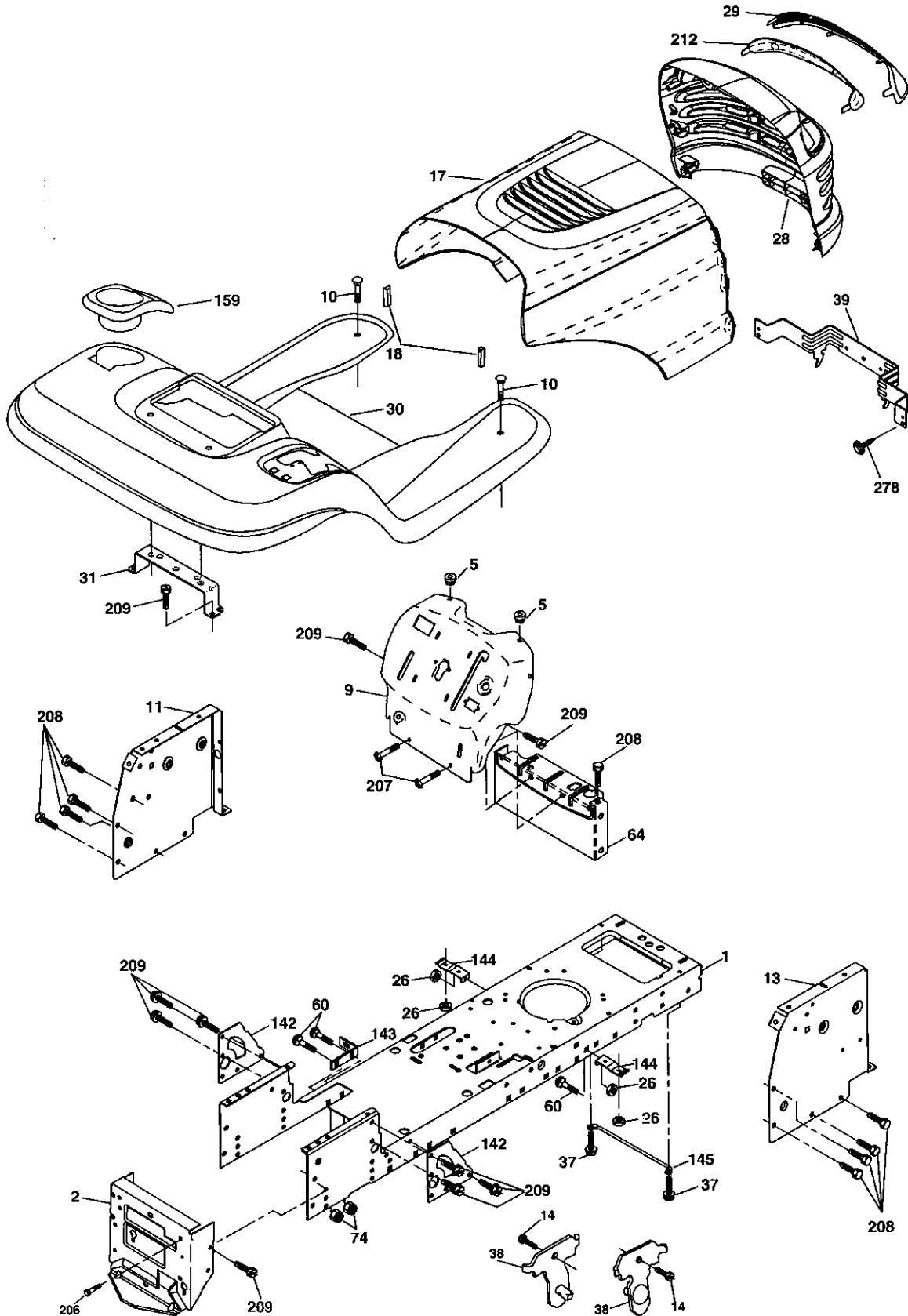

# REPAIR PARTS

## TRACTOR- -MODEL NO. 917. 274180

### CHASSIS AND ENCLOSURES

KEY NO.	PART NO.	DESCRIPTION
1	174619	Chassis
2	176554	Drawbar
5	155272	Bumper Hood/Dash
9	193510X013	Dash
10	STD533710	Bolt, Carriage 3/8-16 x 1
11	174996	Panel, Dash, L.H.
13	172105X010	Panel, Dash, R.H.
14	17490608	Screw Thdrol 3/8-16 x 1/2
17	185682X613	Hood Assembly
18	184921	Bumper Hood
26	STD541437	Nut
28	193258	Grille/Lens Asm. (Includes Key Nos. 29 and 212)
29	174332X599	Lens
30	192393X613	Fend/Ftrest
31	139976	Bracket, Fender Support
37	17490508	Screw Thdrol 5/16-18 x 1/2
38	175710	Pivot Bracket Assembly, Rear
39	174714	Bracket Pivot Laser Lt
60	72140606	Bolt Rdhd Sqnk 3/8-16 unc x 3/4
64	154798	Dash Lower STLT
74	STD541437	Nut Crownlock 3/8-16 unc
142	175702	Plate Reinforcement STLT
143	186689	Bracket Swaybar Chassis
144	175582	Bracket Pnt Footrest STLT
145	156524	Rod Pivot Chassis/Hood
159	155123X428	Cupholder Stlt Black
206	170165	Bolt Shoulder 5/16-18 TT
207	17670508	Screw Thdrol 5/16-18 x 1/2 Tytt
208	17670608	Screw Thdrol 3/8-16 x 1/2
209	17000612	Screw Hexwsh Thdr 3/8-16 x 3/4
212	175143	Insert Lens Reflective
278	191611	Screw 10 x 3/4 Single Lead-Hex
--	5479J	Plug, Button

**NOTE:** All component dimensions given in U.S. inches  
1 inch = 25.4 mm

# REPAIR PARTS

TRACTOR- -MODEL NO. 917. 274180

## DRIVE

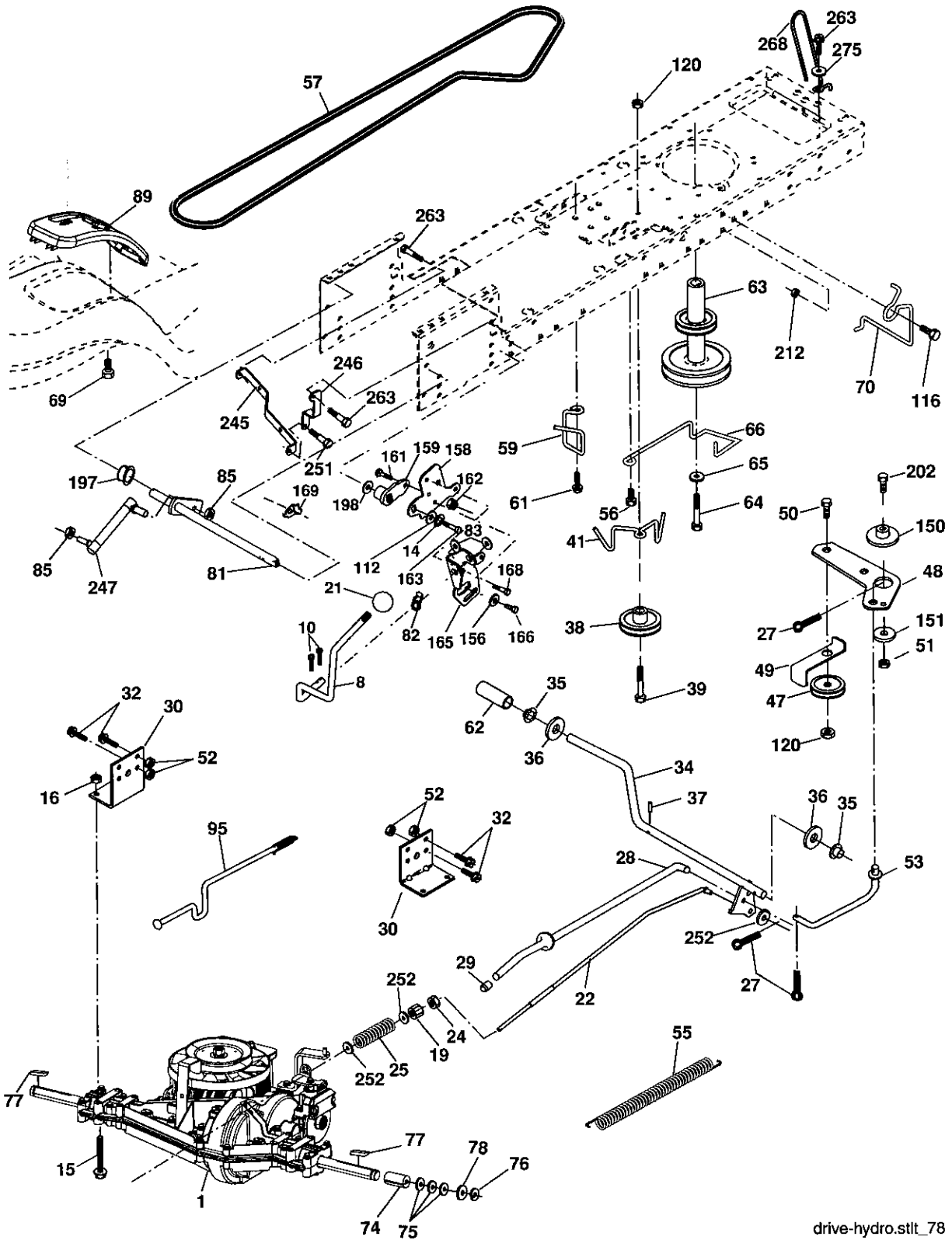

drive-hydro.stlt\_78



# REPAIR PARTS

## TRACTOR- -MODEL NO. 917. 274180

### DRIVE

KEY NO.	PART NO.	DESCRIPTION	KEY NO.	PART NO.	DESCRIPTION
1	-----	Transaxle Peerless LTH2000 (See Breakdown)	70	180218	Guide Belt Mower
8	192502	Rod Shift Fender Adjust	74	137057	Spacer
10	STD561210	Pin Cotter 1/8 x 1 CAD	75	121749X	Washer 25/32 x 1-1/4 x 16 Ga.
14	10040400	Washer Lock Hvy Helical	76	STD581075	E-Ring
15	74490544	Bolt Hex FLGHD 5/16-18 Gr. 5	77	123583X	Key, Square
16	STD541431	Nut Lock Hex W/Ins. 5/16-18 unc	78	121748X	Washer 25/32 x 1-5/8 x 16 Ga.
19	STD541437	Nut Lock Hex W/Wsh 3/8-16 unc	81	178139	Shaft Asm Cross Tapered
21	130564	Knob	82	165711	Spring Torsion
22	178141	Rod, Brake	83	19171216	Washer 17/32 x 3/4 x 16 Ga.
24	73350600	Nut, Hex Jam 3/8-16 unc	85	150360	Nut Lock Center 1/4-28 FNTHD
25	106888X	Spring, Brake Rod	89	192387X428	Console, Shift
27	STD561210	Pin Cotter 1/8 x 3/4 CAD.	95	178134	Disconnect Asm Rod Bypass LTH
28	175765	Rod, Parking Brake	112	19091210	Washer 9/32 x 3/4 x 10 Ga.
29	71673	Cap, Parking Brake	116	72140608	Bolt Rdhd Sqneck 3/8-16 x 1
30	169592	Bracket, Transaxle	120	73900600	Nut Lock Flg 3/8-16
32	74760512	Bolt Hex Hd 5/16-18 unc x 3/4	150	175456	Spacer Retainer
34	175578	Shaft, Foot Pedal	151	19133210	Washer 13/32 x 2 x 10 Ga.
35	120183X	Bearing, Nylon	156	166002	Washer Srrted 5/16 ID x 1.125
36	19211616	Washer	158	165589	Bracket Shift Mount
37	1572H	Pin, Roll	159	183900	Hub Shift
38	179114	Pulley, Composite	161	72140406	Bolt Rdhd Sqnk 1/4-20 x 3/4 Gr. 5
39	72110622	Bolt Rdhd 3/8-16 unc x 2-3/4 Gr. 5	162	73680400	Nut Crownlock 1/4-20 unc
41	175556	Keeper, Belt Idler	163	74780416	Bolt Hex Fin 1/4-20 unc x 1 Gr. 5
47	127783	Pulley, Idler, V-Groove	165	165623	Bracket Pivot Lever
48	154407	Bellcrank, Clutch	166	17490510	Screw 5/16-18 x 5/8
49	123205X	Retainer, Belt	168	165492	Bolt Shoulder 5/16-18 x .561
50	72110612	Bolt Carr Sh 3/8-16 x 1-1/2 Gr. 5	169	165580	Plate Fastening
51	STD541437	Nut Crownlock 3/8-16 unc	197	169613	Nyliner Snap-In 5/8"ID
52	STD541431	Nut, Crownlock 5/16-18 unc	198	169593	Washer Nyl 7/8 ID x .105" Hyd
53	199652	Link, Clutch	202	72110614	Bolt Carr Sh 3/8-16 x 1-3/4 Gr.5
55	105709X	Spring, Return, Clutch	212	145212	Nut Hex Flange Lock
56	17060620	Screw 3/8-16 x 1-1/4	245	178122	Strap Torque Lh LTH2000
57	178138	V-Belt	246	178121	Strap Torque Rh LTH2000
59	169691	Keeper, Center Span	247	181462	Link Shift Transaxle LTH2000
61	17120614	Screw 3/8-16 x .875	251	17060516	Screw 5/16-18 x 1
62	8883R	Cover, Pedal	252	19131616	Washer 13/32 x 1 x 16 Ga.
63	180219	Pulley, Engine	263	17000612	Screw Hex Wsh Thdr 3/8-16 x 3/4
64	173937	Bolt Hex 7/16-20 x 4 Gr. 5	268	182402	Guard Muffler RH
65	STD551143	Washer	275	19131614	Washer 13/32 x 1 x 14 Ga.
66	154778	Keeper Belt Engine Hydro			
69	142432	Screw Hex Wsh Hi-Lo 1/4-1/2 unc			

**NOTE:** All component dimensions given in U.S. inches  
1 inch = 25.4 mm

# REPAIR PARTS

TRACTOR- -MODEL NO. 917. 274180

## STEERING ASSEMBLY

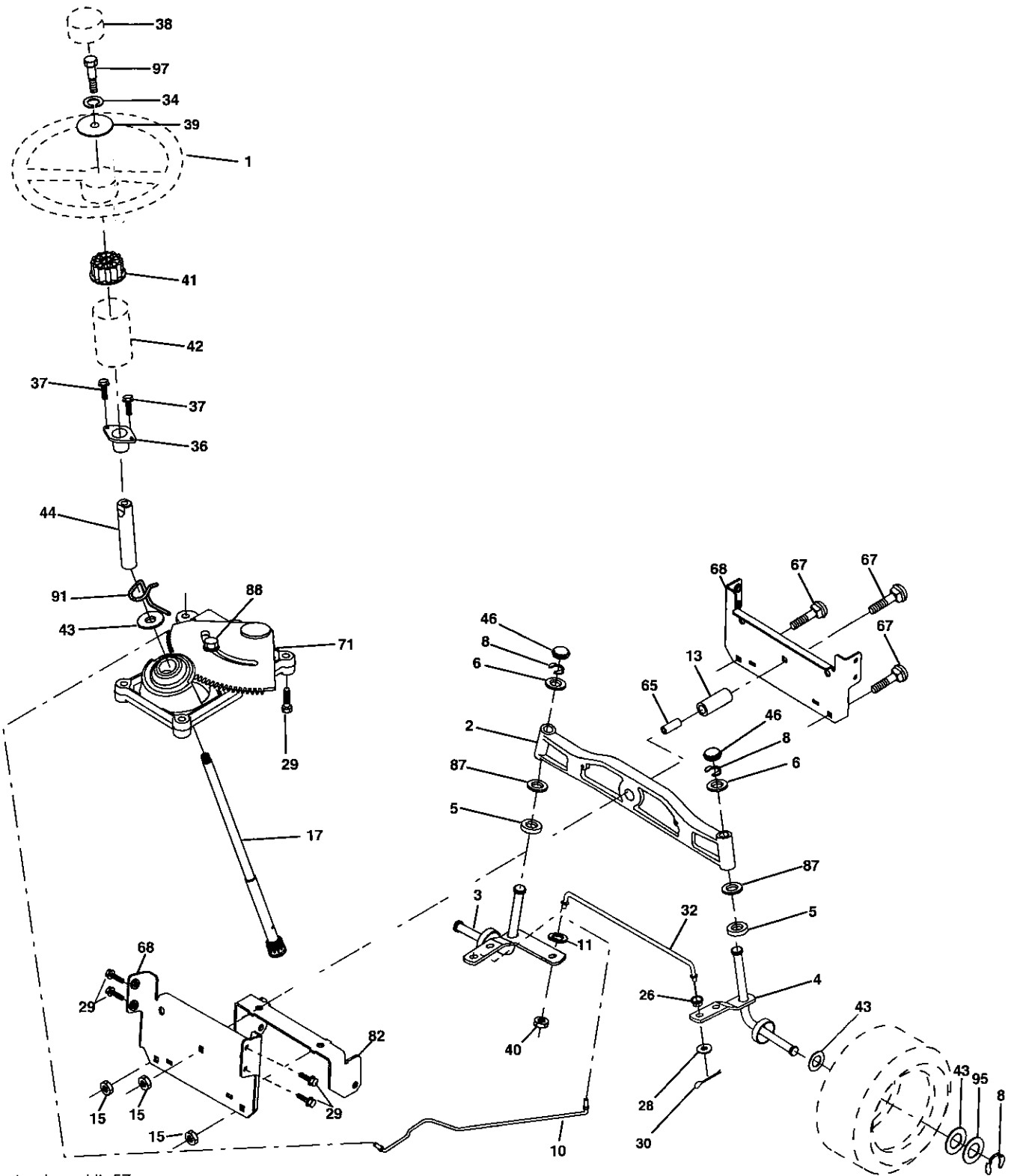

steering\_pl.lt\_57

# REPAIR PARTS

## TRACTOR- -MODEL NO. 917. 274180

### STEERING ASSEMBLY

KEY NO.	PART NO.	DESCRIPTION
1	186780	Steering Wheel
2	184706	Axle Assembly Cast Iron
3	169840	Spindle Assembly, L.H.
4	169839	Spindle Assembly, R.H.
5	6266H	Bearing, Race, Thrust, Hardened
6	121748X	Washer 25/32 x 1-5/8 x 16 Ga.
8	12000029	Ring, Klip
10	175121	Draglink
11	STD551137	Washer, Lock
13	136518	Spacer Bearing Axle Front
15	145212	Nut, Hex Flange Lock
17	190753	Shaft, Steering
26	126847X	Bushing, Link, Drag
28	19131416	Washer 13/32 x 7/8 x 16 Ga.
29	17000612	Screw 3/8-16 x 3/4
30	STD561210	Pin Cotter
32	192757	Rod, Tie
34	10040500	Washer Split Hvy Hlcl Spr. 5/16
36	155099	Bushing, Steering
37	152927	Screw
38	186781	Insert, Steering Wheel
39	19113812	Washer 11/32 x 2-3/8 12 Ga.
40	73540600	Nut Crownlock 3/8-24
41	186737	Adaptor, Steering Wheel
42	145054X428	Boot, Steering Shaft
43	121749X	Washer 25/32 x 1-1/4 x 16 Ga.
44	190752	Extension Shaft Steering
46	184946X505	Cap, Spindle
65	160367	Spacer Brace Axle
67	72110618	Bolt RDHD Sqnk 3/8-16 x 2-1/4
68	169827	Axle, Brace
71	175146	Steering Asm.
82	199978	Bracket Susp. Chassis Front
87	173966	Washer Flat .781 x 1-1/2 x .14
88	175118	Bolt Shoulder 7/16-20 unc
91	175553	Clip Steering
95	188967	Washer Hardened
97	74780564	Bolt 5/16-18 unc x 4 Gr. 5

**NOTE:** All component dimensions given in U.S. inches  
1 inch = 25.4 mm

# REPAIR PARTS

TRACTOR- -MODEL NO. 917. 274180

## ENGINE

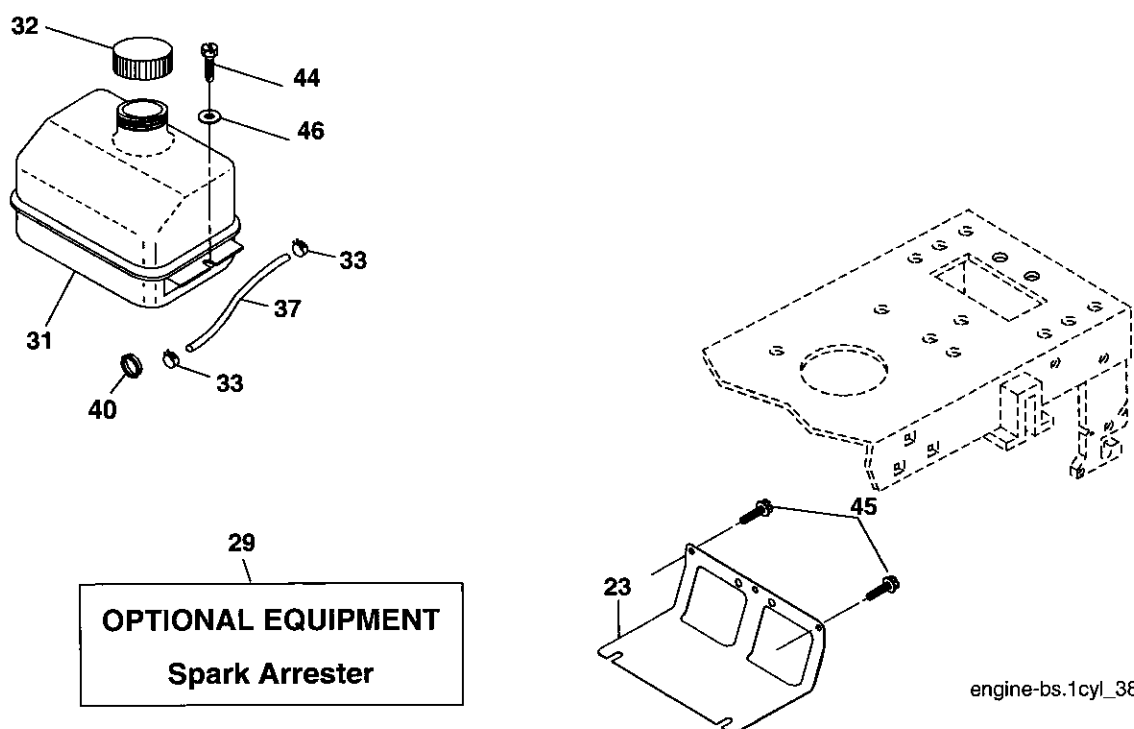
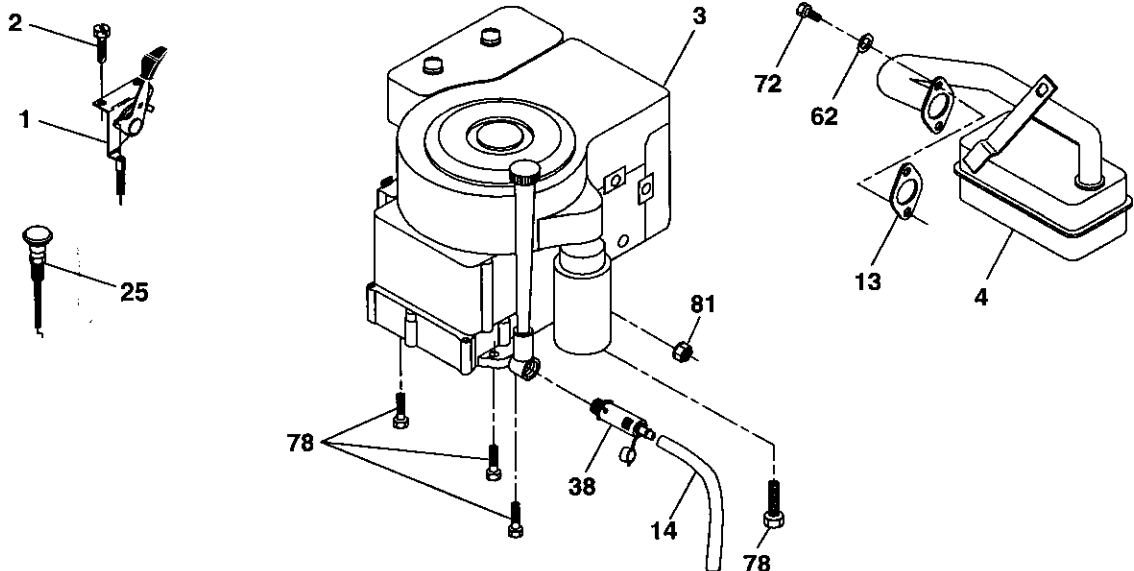

**OPTIONAL EQUIPMENT**  
**Spark Arrester**

engine-bs.1cyl\_38

# REPAIR PARTS

## TRACTOR- -MODEL NO. 917. 274180

### ENGINE

KEY NO.	PART NO.	DESCRIPTION
1	170545X505	Control, Throttle/Choke
2	17720408	Screw, Hex Head, Thread Cutting 1/4-20 x 1/2
3	-----	Engine, Briggs Model 31P777-0565-B1 (See Breakdown)
4	137352	Muffler
13	165291	Gasket
14	148456	Tube Drain Oil Easy
23	169837	Shield Brn/Dbr Guard
25	187770X428	Control Choke
29	137180	Arrestor, Spark
31	187750	Tank, Fuel
32	197725	Cap Assembly, Fuel Top
33	123487X	Clamp, Hose
37	137040	Line, Fuel
38	181654	Plug Drain Oil Easy
40	124028X	Bushing Snap
44	17670412	Screw, Hex Washer Head, Thd., Roll. 1/4-20 x 3/4
45	17000612	Screw Hxwsh Thdr 3/8-16 x 3/4
46	19091416	Washer 9/32 x 7/8 x 16 Ga.
62	10010500	Washer Split
72	192334	Screw Head Hd 5/16-18 x .75
78	17060620	Screw 3/8-16 x 1-1/4
81	73510400	Nut Keps Hex 1/4-20

**NOTE:** All component dimensions given in U.S. inches  
1 inch = 25.4 mm

# REPAIR PARTS

## TRACTOR- -MODEL NO. 917. 274180

### SEAT ASSEMBLY

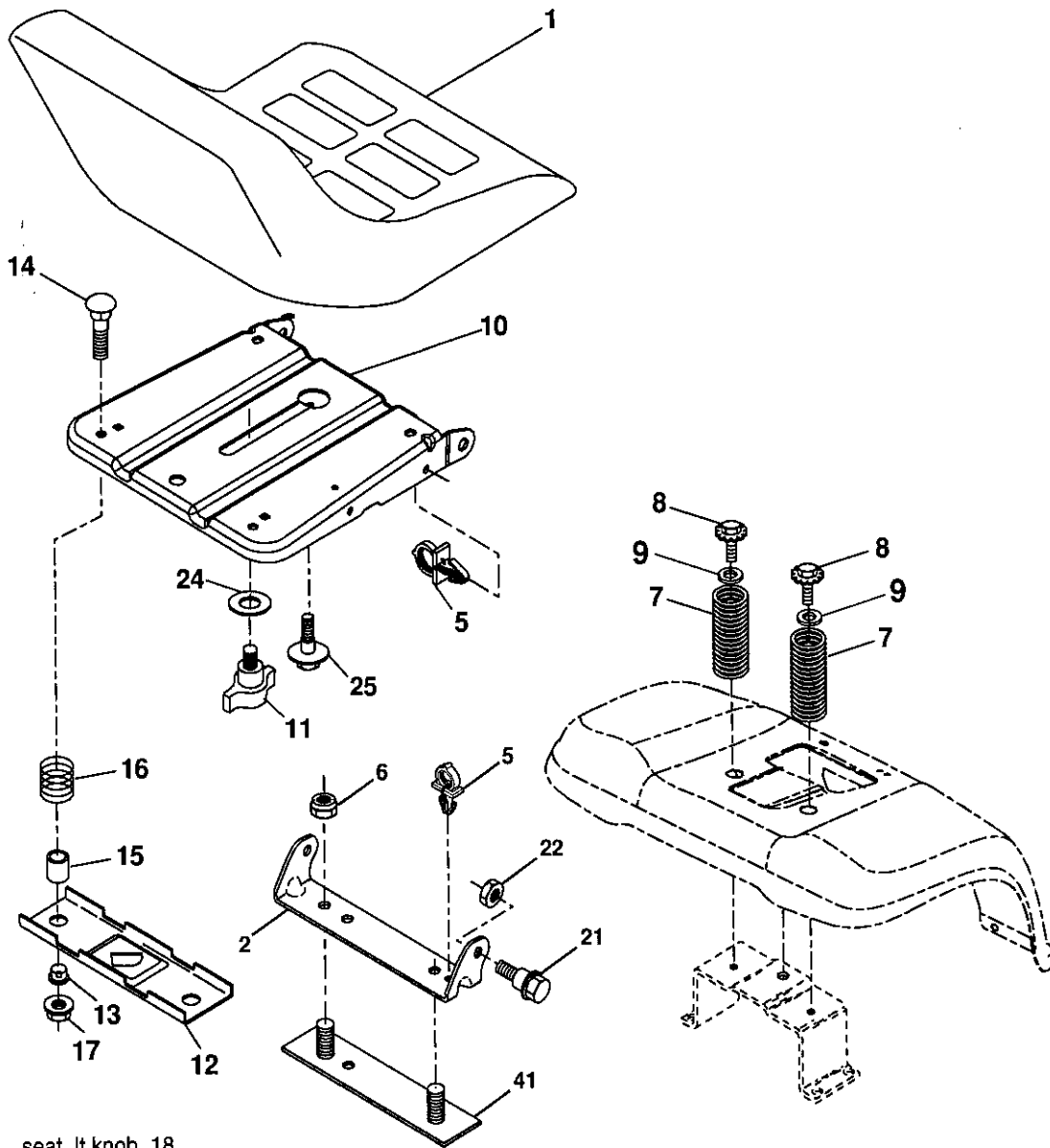

seat\_lt.knob\_18

KEY NO.	PART NO.	DESCRIPTION
1	188939	Seat
2	140551	Bracket Pivot Seat
5	145006	Clip Push In Hinged
6	STD541437	Nut Hex Lock w/Ins 3/8-16 unc
7	124181X	Spring Seat Cprsn 2 250 Blk Zi
8	17000616	Screw 3/8-16 x 1
9	19131614	Washer 13/32 x 1 x 14 Ga.
10	195530	Pan Asm. Seat
11	166369	Knob Seat Adj Wingnut
12	174648	Bracket Pnt Mounting Switch
13	121248X	Bushing Snap Blk Nyl 50 Id
14	72050412	Bolt Rdhd Sht Nk 1/4-20 x 1-1/2

KEY NO.	PART NO.	DESCRIPTION
15	134300	Spacer Split 28 x 96 Zinc
16	121250X	Spring Cprsn 1 27 Blk Pnt
17	123976X	Nut Lock 1/4 Lge Flg Gr. 5 Zinc
21	171852	Bolt Shoulder 5/16-18 unc-2A
22	STD541431	Nut Hex Lock w/Ins 5/16-18
24	19171912	Washer 17/32 x 1-3/16 x 12 Ga.
25	127018X	Bolt Shoulder 5/16-18 x .62
41	140675	Strap Asm. Fender

**NOTE:** All component dimensions given in U.S. inches  
1 inch = 25.4 mm

# REPAIR PARTS

## TRACTOR- -MODEL NO. 917. 274180

### DECALS

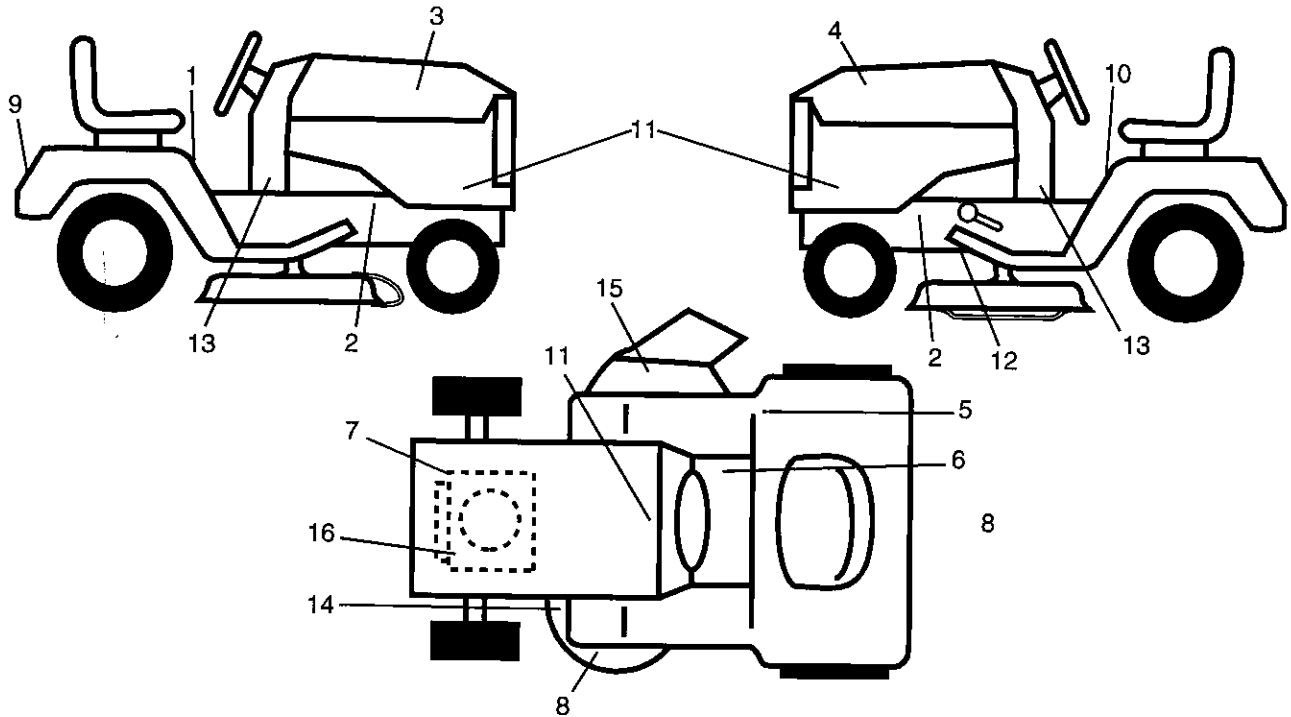

KEY NO.	PART NO.	DESCRIPTION	KEY NO.	PART NO.	DESCRIPTION
1	400389	Decal, Warning Syms. CE	14	160396	Decal, V-Belt Schematic
2	159736	Decal, Chassis Hot Muffler	15	196357	Decal, Deflect Wrn Cutting Finger Sym
3	401124	Decal, Hood, R.H.	16	196841	Decal, Warning Eng. Syms.
4	401125	Decal, Hood, L.H.	20	145005	Decal Battery Dngr/Psn Eng
5	180432	Decal, Fender	--	138311	Decal, Lift Handle
6	140837	Decal, Saddle Brake Parking	--	178392	Decal, Chassis Disconnect
7	197786	Decal, HP Engine	--	162598	Drawbar Load
8	182166	Decal, Cutting Finger CE	--	184310X428	Pad, Footrest LH STLT
9	401127	Decal, Fender	--	184311X428	Pad, Footrest RH STLT
10	159737	Decal, Brake/Clutch	--	404853	Manual, Operator's (Euro)
11	401128	Decal, Panel Side	--	404854	Manual, Operator's (Scan)
12	197490	Decal, V-Belt Drive Schematic	--	404855	Manual, Operator's (EBloc)
13	191551	Decal, Chassis	--	404856	Manual, Operator's (Baltic)
			--	404857	Manual, Parts

### WHEELS & TIRES

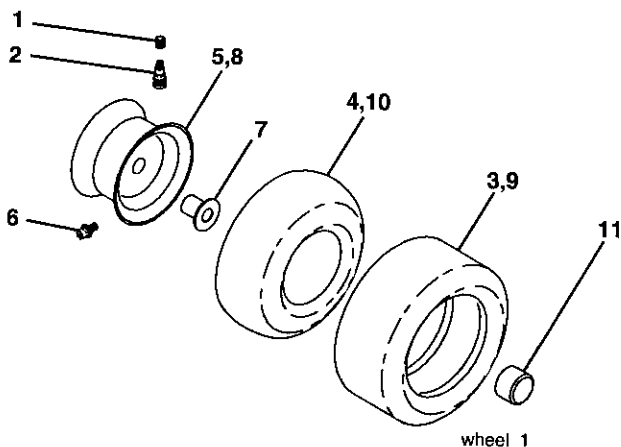

KEY NO.	PART NO.	DESCRIPTION
1	59192	Cap Value Tire
2	65139	Stem Value
3	106222X	Tire F Ts 15 x 6.0 - 6 Service
4	59904	Tube Inner Front #35060
5	106732X643	Rim Asm 6" front Service
6	278H	Fitting Grease
7	9040H	Bearing Flange
8	106108X643	Rim Asm 8" rear Service
9	138468	Tire R Ts 20 x 8-8 Service
10	7152J	Tube Rear 9.5 x 8 Service
11	104757X643	Cap Axle BIK 1 50 x 1 00
--	144334	Sealant, Tire (10 oz. tube)

**NOTE:** All component dimensions given in U.S. inches  
1 inch = 25.4 mm

# REPAIR PARTS

TRACTOR- -MODEL NO. 917. 274180

## MOWER LIFT

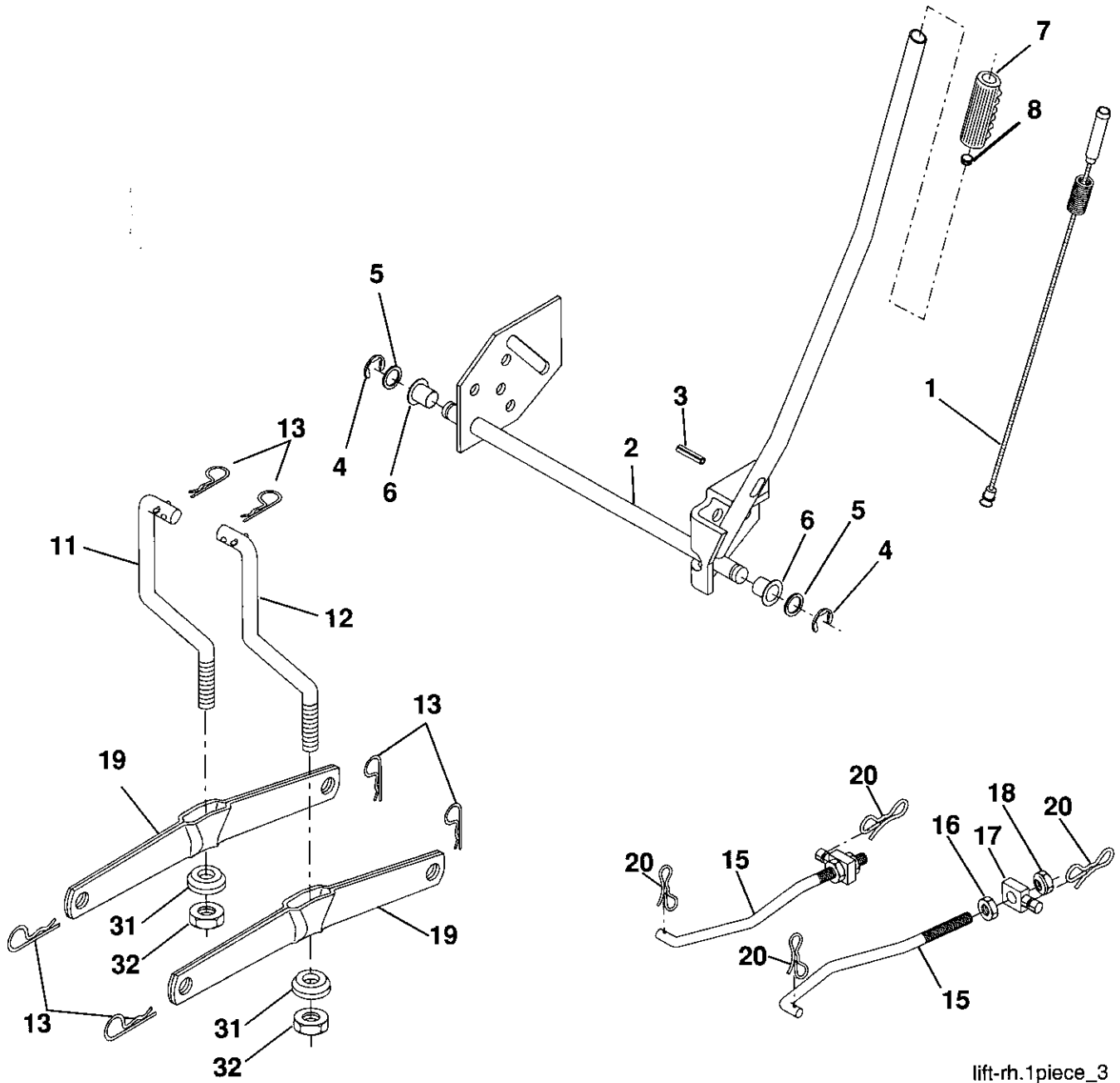

lift-rh.1piece\_3



# REPAIR PARTS

TRACTOR- -MODEL NO. 917. 274180

## MOWER LIFT

KEY NO.	PART NO.	DESCRIPTION
1	159460	Washer Asm Inner Spring W/Plunger
2	159471	Shaft Asm. Lift
3	105767X	Pin Groove
4	12000002	E Ring #5133-62
5	19211621	Washer 21/32 x 1 x 21 Ga.
6	120183X	Bearing Nylon
7	125631X	Grip Handle Fluted
8	122365X	Button Plunger Read
11	139865	Link Asm Lift L.H.
12	139866	Link Asm Lift R.H.
13	STD624008	Retainer Spring
15	173288	Link Front
16	73350800	Nut Jam Hex 1/2-13 unc
17	175689	Trunnion Blk Zinc
18	73800800	Nut Lock w/Wsh 1/2-13 unc
19	139868	Arm Suspension Mower
20	194209	Pin Cotter 7/16 Bow Tie Lock
31	169865	Bearing, Pvt. Lift
32	73540600	Nut Crownlock 3/8-24

**NOTE:** All component dimensions given in U.S. inches  
1 inch = 25.4 mm

# REPAIR PARTS

TRACTOR- -MODEL NO. 917. 274180

MOWER

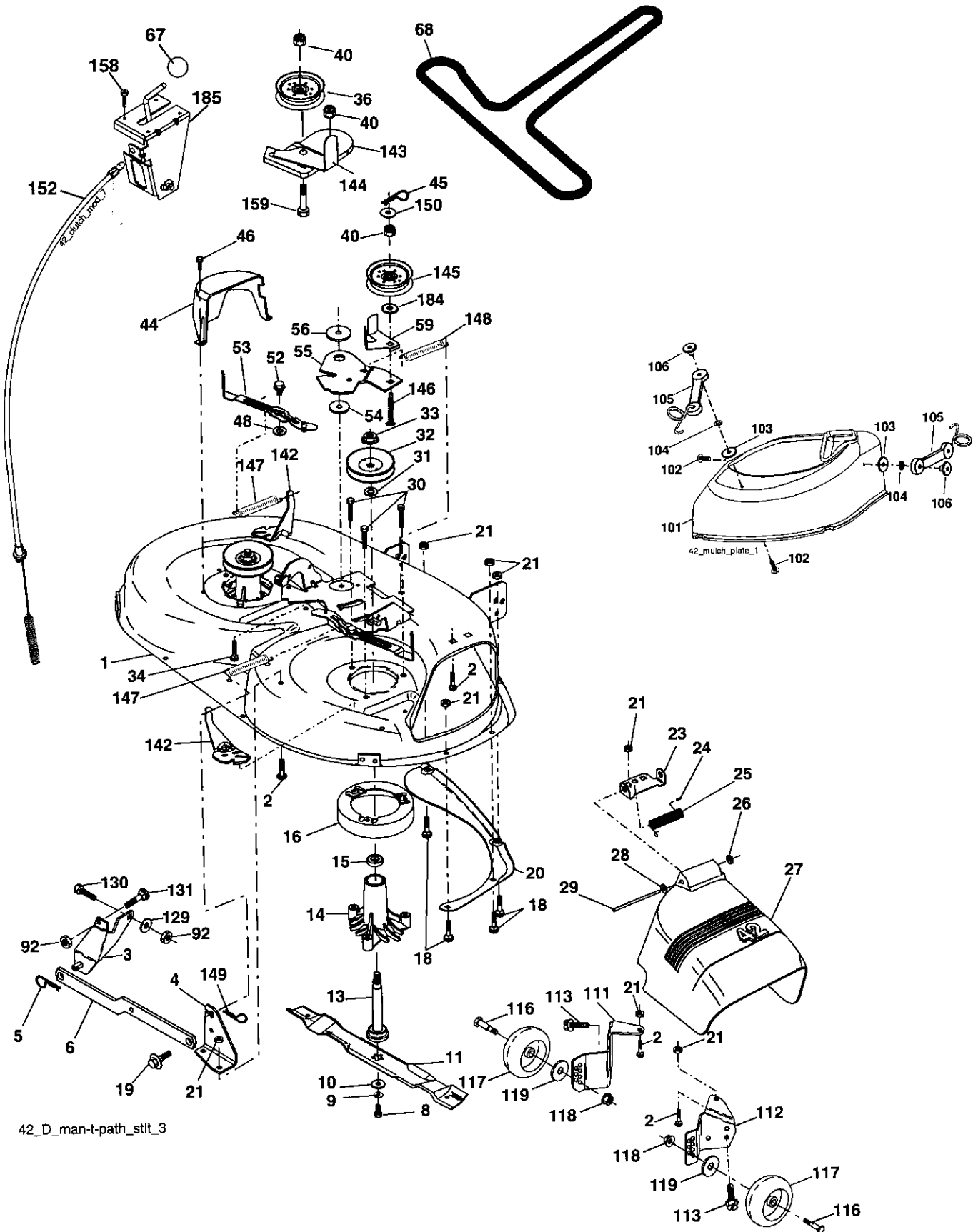

42\_D\_man-t-path\_stit\_3

# REPAIR PARTS

## TRACTOR- -MODEL NO. 917. 274180

### MOWER

KEY NO.	PART NO.	DESCRIPTION	KEY NO.	PART NO.	DESCRIPTION
1	165892	Mower Deck Assembly, 42"	68	180215	V-Belt
2	STD533107	Bolt	92	STD541437	Nut
3	138017	Bracket Assembly, Sway Bar, Front	101	193107	Cover Mulching
4	165460	Bracket Sway Bar 38/42" Deck	102	71081010	Screw Pan Hd Phillips 10-24 x 5/8
5	STD624008	Retainer Spring	103	19061216	Washer # 10
6	178024	Bar Sway Deck	104	10071000	Washer Lock #10
8	850857	Bolt, Hex 3/8-24 x 1.25 Gr. 8	105	160793	Latch Asm. Mulch/Bagger
9	STD551137	Washer, Lock	106	2029J	Nut Weld .327/.304 #10-24
10	140296	Washer, Hardened	111	179292	Bracket Gauge Wheel Lh
11	134149	Blade, 42" Mulching Std (For mulching mowers only)	112	179293	Bracket Gauge Wheel Rh
13	137645	Shaft Assembly, Mandrel, Vented	113	17000510	Screw 5/16-18 unc
14	128774	Housing, Mandrel, Vented	116	4898H	Bolt Shoulder
15	110485X	Bearing, Ball, Mandrel	117	188606	Wheel Gauge
16	174493	Stripper, Vented Mower Deck	118	73930600	Nut Centerlock 3/8-16 unc
18	72140505	Bolt, Carriage 5/16-18 x 5/8	119	19121414	Washer 3/8 x 7/8 x 4 Ga.
19	132827	Bolt, Shoulder	129	19131312	Washer 13/32 x 13/16 x 12 Ga.
20	159770	Baffle, Vortex	130	STD523710	Bolt, Fin Hex 3/8-16 unc x 1 Gr. 5
21	STD541431	Nut Crownlock 5/16-18 unc	131	STD533710	Bolt, Rdhd Sqnk 3/8-16 unc x1
23	177563	Bracket, Deflector	142	165890	Arm Spring Brake Mower
24	105304X	Cap, Sleeve	143	157109	Bracket Arm Idler 42"
25	123713X	Spring, Torsion, Deflector	144	158634	Keeper Beit 42" Clutch Cable
26	110452X	Nut, Push	145	165888	Pulley Idler Flat
27	130968X428	Shield, Deflector	146	171977	Bolt Carriage Idler
28	19111016	Washer 11/32 x 5/8 x 16 Ga.	147	179748	Spring Extension
29	131491	Rod, Hinge	148	169022	Spring Return Idler
30	173984	Screw Thdrol Washer Head	149	165898	Retainer Spring Yellow Zinc
31	187690	Washer, Spacer	150	19091210	Washer 9/32 x 3/4 x 10 Ga.
32	153535	Pulley, Mandrel	152	181555	Cable Clutch 42 In
33	400234	Nut, Toplock, Flanged	158	17720408	Screw Hex Thd Cut 1/4-20 x 1/2
34	STD533717	Bolt	159	72140614	Bolt Rdhd Sqn 3/8-16 unc x 3/4
36	131494	Pulley, Idler, Flat	184	19131410	Washer 13/13 x7/8 x 10 Ga.
40	73900600	Nut Lock Flg 3/8-16 unc	185	188234	Head Asm Cable Clutch
44	140088	Guard, Mandrel, L.H.	--	130794	Mandrel Assembly (Includes Housing, Shaft and Shaft Hardware Only - Pulley Not Included)
45	STD624003	Retainer	--	181281	Replacement Mower, Complete (Std. Deck-Order separately gauge wheel components key nos. 116 - 119).
46	137729	Screw, Thd. Roll 1/4-20 x 5/8			
48	133944	Washer, Hardened			
52	139888	Bolt, Shoulder 5/16-18 unc			
53	184907	Arm Assembly, Pad, Brake			
54	178515	Washer, Hardened			
55	155046	Arm, Idler			
56	165723	Spacer, Retainer			
59	141043	Guard, TUV Idler			
67	184939	Knob Custom Oval			

**NOTE:** All component dimensions given in U.S. inches  
1 inch = 25.4 mm

# REPAIR PARTS

TRACTOR- -MODEL NO. 917. 274180

PEERLESS TRANSAXLE - MODEL NUMBER LTH2000

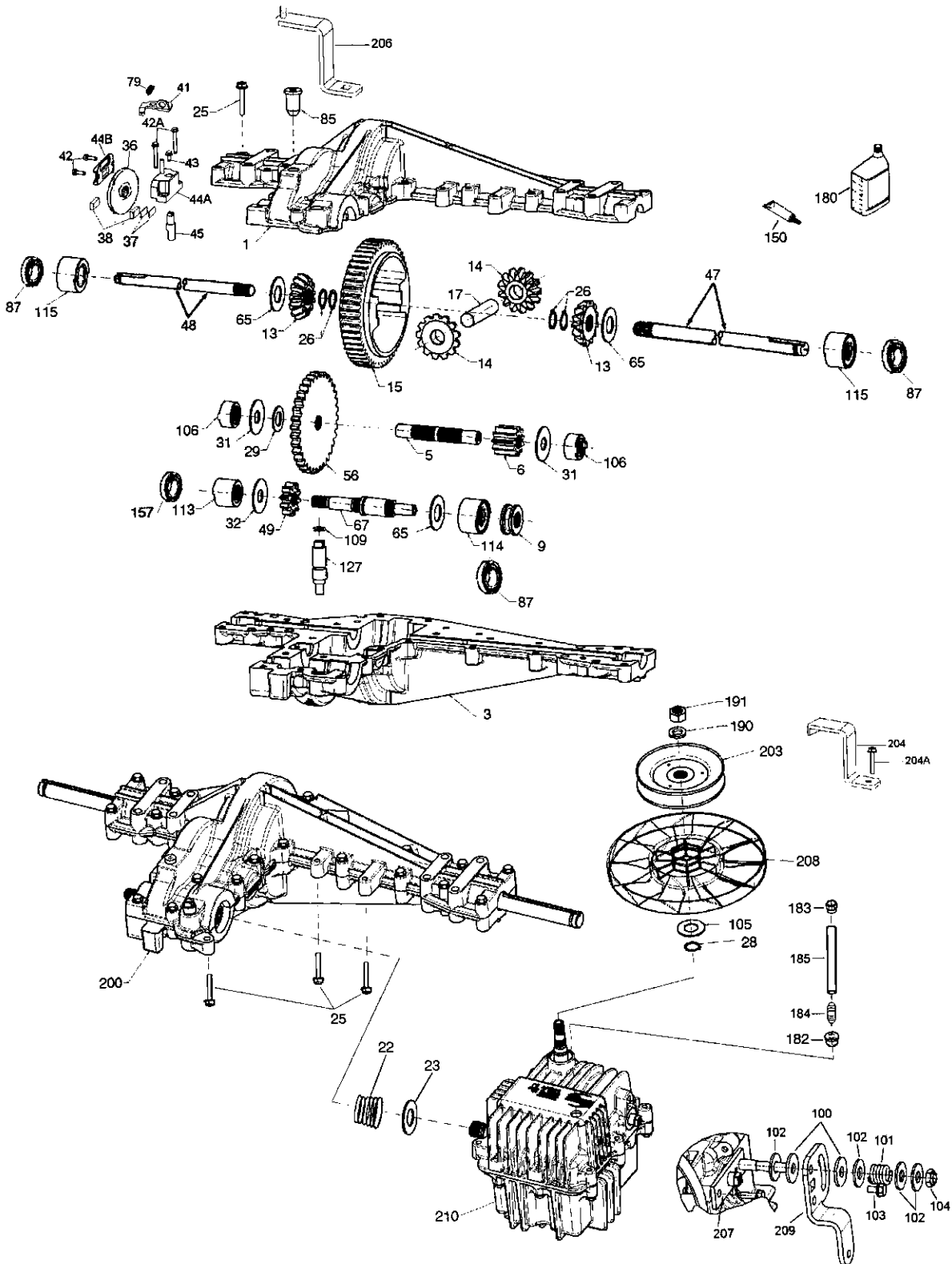

# REPAIR PARTS

## TRACTOR- -MODEL NO. 917. 274180

### PEERLESS TRANSAXLE - MODEL NUMBER LTH2000

KEY NO.	PART NO.	DESCRIPTION	KEY NO.	PART NO.	DESCRIPTION
1	772151	Cover L.H.	70	786196	Spacer .625 .765
3	770135	Case	79	792201	Spring
5	776355	Counter Shaft	85	792154	Oil Fill Plug
6	778263	Spur Gear 11T	87	788088A	Oil Seal 3/4"
9	786197	Neutral Sleeve (.572)	99	792141	Washer .377ID .058W
13	778368	Bevel Gear (Incl. 14) (13 Teeth)	100	792200	Snubber Washer
14	778368	Bevel Gear (Incl. 13) (13 Teeth)	101	792199	Snubber Spring .47ID
15	778373	Ring Gear (54 Teeth)	102	792184	Washer .437ID .078W
17	786139	Drive Pin	103	792193	Screw, 1/4-28 x .490
22	792194	Spring	104	792198	Nut, 3/8-24
23	792195	Washer .750 ID	105	780096	Washer .625 ID .057W
25	792073A	Screw 1/4-20 x 1-1/4"	106	786162	Sleeve Assembly
26	792125	Retaining Ring	107	792046	Screw, 1/4-20 x 1"
28	792035	Retaining Ring	109	788104	"O" Ring
29	780065	Washer .627 ID .091W	113	786199	Sleeve Ass'y (Incl. 157)
31	780189	Washer .563 ID .062W	114	786200	Sleeve Ass'y (Incl. 87)
36	790071	Brake Disk	115	786198	Sleeve Assembly (Incl. 87)
37	790007	Brake Pad Plate	127	784384	Shift Lever Ass'y (Incl. 109)
38	799021	Brake Pad	150	788093A	Liquid Gasket RTV Silicon
40	792204	Roll Pin .25	157	788102	Oil Seal 9/16"ID
41	790102	Brake Lever	180	730229	BOil Spec. (80W90)
42	792202	Screw, 1/4-20 x 3/4	182	788103	Grommet
42A	792203	Screw, 1/4-20 x 1-3/4	183	792118	Relief Valve
43	792171	Screw, 10-24 x .500	184	792196	Hose Barb
44A	790100	Inside Brake (Mach)	185	798050	Tubing 1/2 x 5
44B	790099	Outside Brake (Casting)	190	792150	Washer
45	790101	Actuator Rod	191	792151	Nut 7/16-20
47	774869	Axle 16.812	200	794787	Differential (Gear Reduction Drive)
48	774688	Axle 11.625	203	798044	Pulley & Hub Ass'y
49	778378	Spur Gear 18T	206	798055	Disconnect Lever
56	778379	Spur Gear 81T	207	798053	Mounting Plate
65	780195	Washer .750ID .062W	208	798040	Fan
67	776440	Brakeshaft	209	798054	Control Lever
			210	794788	Hydro Module LH Fender Control

# REPAIR PARTS

TRACTOR--MODEL NO. 917. 274180

BRIGGS & STRATTON ENGINE -- MODEL NUMBER 31P777, TYPE NUMBER 0565-B1

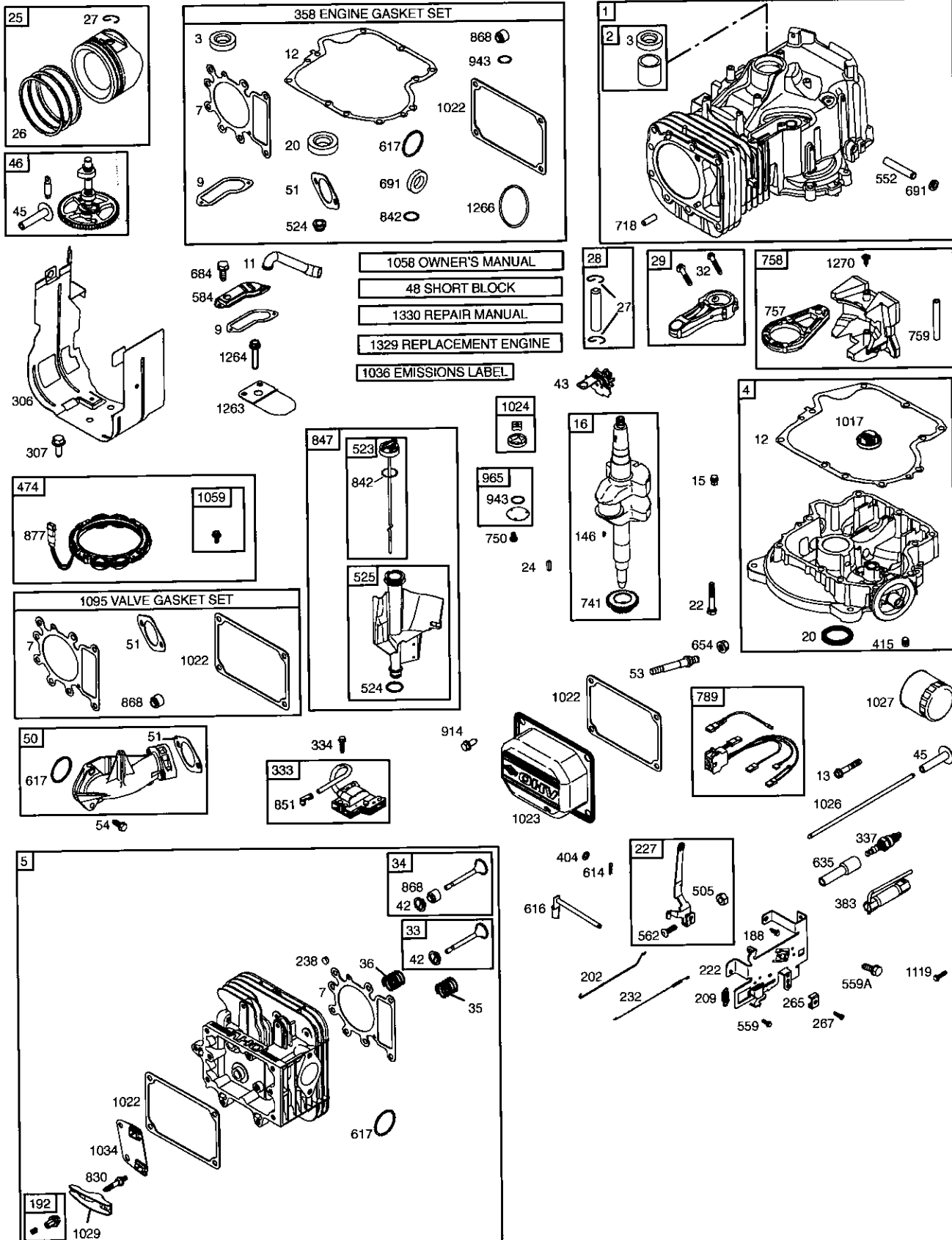

# REPAIR PARTS

TRACTOR - - MODEL NO. 917. 274180

BRIGGS & STRATTON ENGINE - - MODEL NUMBER 31P777, TYPE NUMBER 0565-B1

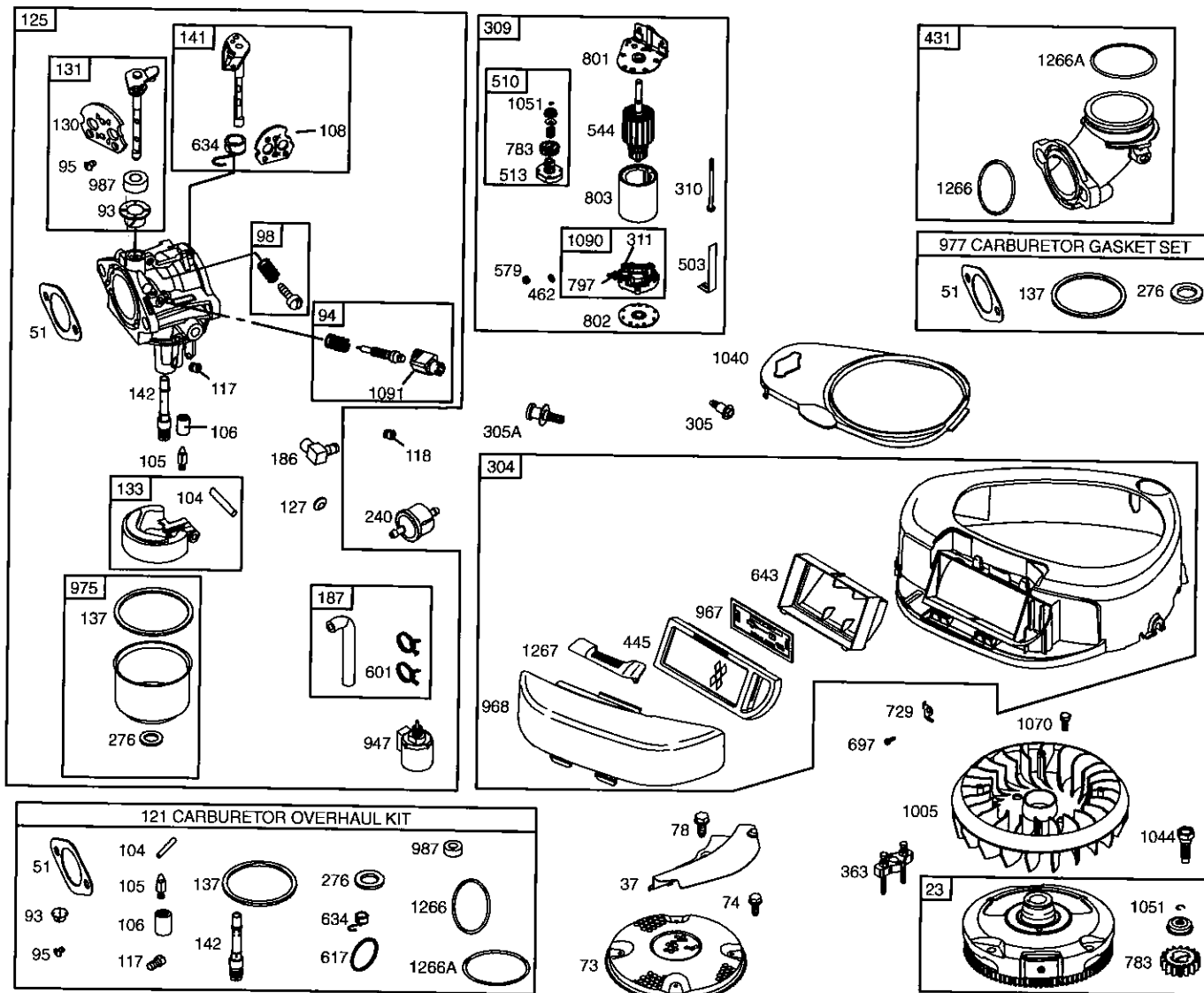

# REPAIR PARTS

## TRACTOR- -MODEL NO. 917. 274180

BRIGGS & STRATTON ENGINE - - MODEL NUMBER 31P777, TYPE NUMBER 0565-B1

KEY NO.	PART NO.	DESCRIPTION	KEY NO.	PART NO.	DESCRIPTION
1	697174	Cylinder Assembly	108A	695419	Valve-Choke (Nikki)
2	399265	Kit-Bushing/Seal (Magneto Side)	117	694352	Ø Jet-Main (Standard) (Walbro)
3	391086s	Seal-Oil (Magneto Side)	117A	699457	Jet-Main (Standard) (Nikki)
4	697188	Sump-Engine	118	697228	Jet-Main (High Altitude) (Walbro)
5	792360	Head-Cylinder	118A	699458	Jet-Main (High Altitude)(Nikki)
7	699168	•+ Gasket-Cylinder Head	121	697241	Kit-Carburetor Overhaul (Walbro)
9	697109	• Gasket-Breather	121A	699521	Kit-Carburetor Overhaul (Nikki)
11	697113	Tube-Breather	125	791888	Carburetor (Walbro)
12	697110	• Gasket-Crankcase	125A	---	Carburetor (Nikki)(For complete carburetor see reference 125)
13	690360	Screw (Cylinder Head)	127	695005	Plug-Welch (Walbro)
15	690946	Plug-Oil Drain	127A	690727	Ø Plug-Welch (Nikki)
16	697127	Crankshaft	130	691750	Valve-Throttle (Walbro)
20	690947	• Seal-Oil (PTO Side)	130A	699500	Valve-Throttle (Nikki)
22	692125	Screw (Crankcase Cover/Sump)	131	494379	Kit-Throttle Shaft (Walbro)
23	693557	Flywheel	131A	699501	Kit-Throttle Shaft (Nikki)
24	222698s	Key-Flywheel	133	494381	Float-Carburetor (Walbro)
25	792118	Piston Assembly (Standard)	133A	694914	Float-Carburetor (Nikki)
--	792668	Piston Assembly (.020" Oversize)	135	698780	Tube-Fuel Transfer
26	791936	Ring Set (Standard)	137	281165sØ‡	Gasket-Float Bowl (Walbro)
--	791947	Ring Set (.020" Oversize)	137A	698781	Ø Gasket-Float Bowl (Nikki)
27	698469	Lock-Piston Pin	141	495097	Kit-Choke Shaft (Walbro)
28	697099	Pin-Piston	141A	695420	Kit-Choke Shaft (Nikki)
29	697126	Rod-Connecting (Standard)	142	697140	Ø Nozzle-Carburetor
--	697263	Rod-Connecting (.020" Undersize)	146	691639	Key-Timing
32	692852	Screw (Connecting Rod)	186	698174	Connector-Hose
33	791934	Valve-Exhaust	187	697098	Line-Fuel (Molded)
34	791935	Valve-Intake	188	691693	Screw (Control Bracket)
35	691279	Spring-Valve (Intake)	192	691986	Adjuster-Rocker Arm
36	691279	Spring-Valve (Exhaust)	202	691841	Link-Mechanical Governor
37	697108	Guard-Flywheel	209	692208	Spring-Governor
42	499586	Retainer-Valve	222	694042	Bracket-Control
43	691968	Slinger-Governor/Oil	227	691374	Lever-Governor Control
45	690564	Tappet-Valve	232	691842	Spring-Governor
46	790400	Camshaft	238	691843	Cap-Valve
48	697762	Short Block	240	394358	Filter-Fuel
50	690193	Manifold-Intake	265	691024	Clamp-Casing
51	692137	•Ø‡+ Gasket-Intake	267	792629	Screw (Casing Clamp)
53	690227	Stud (Carburetor)	276	692255	Ø‡ Washer-Sealing (Walbro)
54	691148	Screw (Intake Manifold)	276A	695410	Washer-Sealing (Nikki)
73	697133	Screen-Rotating	304	699829	Housing-Blower
74	697897	Screw (Rotating Screen)	305	697102	Screw (Blower Housing)
78	691003	Screw (Flywheel Guard)	305A	697103	Screw (Blower Housing)
93	690602	Ø Bushing-Throttle Shaft	306	697107	Shield-Cylinder
94	498030	Kit-Idle Mixture (Walbro)	307	691003	Screw (Cylinder Shield)
94A	695425	Kit-Idle Mixture (Nikki)	309	693551	Motor-Starter
95	691636	Ø Screw (Throttle Valve)(Walbro)			
95A	690718	Ø Screw (Throttle Valve)(Nikki)			
98	495800	Kit-Idle Speed (Walbro)			
98A	6959408	Kit-Idle Speed (Nikki)			
104	690525	Ø Pin-Float Hinge (Walbro)			
104A	694918	Ø Pin-Float Hinge (Nikki)			
105	231855sØ	Valve-Float Needle (Walbro)			
105A	696136	Ø Valve-Float Needle (Nikki)			
106	690577	Ø Seat-Inlet (Walbro)			
108	692344	Valve-Choke (Walbro)			

- Included in Engine Gasket Set, Key. No. 358
- Ø Included in Carburetor Overhaul Kit, Key. No. 121
- ‡ Included in Carburetor Gasket Set, Key. No. 977
- + Included in Valve Gasket Set, Key. No. 1095

**NOTE:** All component dimensions given in U.S. inches 1 inch = 25.4 mm



# REPAIR PARTS

## TRACTOR- -MODEL NO. 917. 274180

### BRIGGS & STRATTON ENGINE - - MODEL NUMBER 31P777, TYPE NUMBER 0565-B1

KEY NO.	PART NO.	DESCRIPTION	KEY NO.	PART NO.	DESCRIPTION
310	690323	Bolt (Starter Motor)	847	790442	Dipstick/Tube Assembly
311	497608	Brush Set	851	692424	Terminal-Spark Plug
333	492341	Armature-Magneto	868	690968	•+ Seal-Valve
334	691061	Screw (Magneto Armature)	914	691108	Screw (Rocker Cover)
337	691043	Plug-Spark	943	690589	• Seal-O Ring (Oil Pump Cover)
358	697191	Gasket Set-Engine	947	694393	Solenoid-Fuel (Walbro)
363	19203	Flywheel Puller	947A	699915	Solenoid-Fuel (Nikki)
383	89838s	Wrench-Spark Plug	965	499613	Cover-Oil Pump
404	691691	Washer (Governor Crank)	967	697015	Filter-Pre Cleaner
415	690283	Plug	968	699848	Cover-Air Cleaner
431	697122	Elbow-Intake	975	495933	Bowl-Float (Walbro)
445	697153	Filter-Air Cleaner Cartridge	975A	699502	Bowl-Float (Nikki)
462	691261	Washer (Starter Cable)	977	690192	Gasket Set-Carburetor
474	696459	Alternator	987	691326	∅ Seal-Throttle Shaft (Walbro)
503	691532	Strap-Starter	987A	698777	∅ Seal-Throttle Shaft (Nikki)
505	691251	Nut (Governor Control Lever)	1005	699043	Fan-Flywheel
510	693699	Drive-Starter	1017	690770	Screen-Oil Pump
513	692024	Clutch-Drive	1022	272475s*+	Gasket-Rocker Cover
523	699908	Dipstick	1023	692492	Cover-Rocker Arm
524	691032	• Seal-Dipstick Tube	1024	499054	Pump-Oil
525	697085	Tube-Dipstick	1026	692003	Rod-Push (Intake)
544	692034	Starter-Armature	-- --	692011	Rod-Push (Exhaust)
552	697144	Bushing-Governor Crank	1027	492932s	Filter-Oil
559	697561	Screw (Remote Choke Stop)	1029	691751	Arm-Rocker
559A	693675	Screw (Remote Choke Stop)	1034	690822	Guide-Push Rod
562	691119	Bolt (Governor Control Lever)	1036	792450	Label-Emissions
579	691029	Nut (Starter Cable)	1040	699852	Plate-Trim
584	697112	Cover-Breather Passage	1044	698139	Screw (Flywheel)
601	791850	Clamp-Hose	1051	691265	Ring-Retaining
614	691620	Pin-Cotter	1058	275935	Owner's Manual
616	692012	Crank-Governor	1059	698516	Kit-Screw/Washer
617	692138	∅ • Seal-O Ring (Intake Manifold)	1070	691058	Screw (Flywheel Fan)
634	690801	∅ Spring/Seal Assembly (Walbro)	1090	691293	Retainer-Brush
634A	698779	∅ Spring/Seal Assembly (Nikki)	1091	691333	Cap-Limiter
635	691909	Boot-Spark Plug	1095	690190	Gasket Set-Valve
643	698401	Retainer-Air Filter	1119	691183	Screw (Alternator)
654	690958	Nut (Carburetor)	1127	691657	Screw (Float Bowl) (Nikki)
684	697157	Screw (Breather Passage Cover)	1263	697124	Reed-Breather
691	692407	• Seal-Governor Shaft	1264	697104	Screw (Breather Reed)
697	690372	Screw (Drive Cap)	1266	691917	•∅ Seal-O Ring (Intake Elbow)
718	690959	Pin-Locating	1266A	697123	•∅ Seal-O Ring (Intake Elbow)
729	691224	Clip-Wire	1267	697424	Latch-Blower Housing
741	697128	Gear-Timing	1270	697156	Plug-AVS Counterweight
750	691033	Screw (Oil Pump Cover)	1329	31Q777-0036	Replacement Engine (Transfer the speed limiter control assembly to the replacement engine. Remove 691840.)
757	697607	Link-Counterweight			Repair Manual
758	697134	Counterweight			
759	697392	Pin-Counterweight			
783	693713	Gear-Pinion			
789	698329	Harness-Wiring	1330	272147	
797	693167	Nut (Brush Retainer)			
801	691283	Cap-Drive			
802	691286	Cap-End			
803	693757	Housing-Starter			
830	691095	Stud (Rocker Arm)			
842	691031	• Seal-O Ring (Dipstick Tube)			

**NOTE:** All component dimensions given in U.S. inches 1 inch = 25.4 mm

---

# SERVICE NOTES

---

## **LIMITED WARRANTY ON CRAFTSMAN TRACTOR AND BATTERY**

### **2-YEAR ON TRACTOR**

When used and maintained according to the operator's manual instructions, if this tractor fails due to a defect in material or workmanship within two years from the date of purchase, call 1-800-4-MY-HOME® to arrange for free repair.

During the first 30 days of purchase, there will be no charge to service the product in your home. For your convenience, in-home warranty service will still be available after the first 30 days of purchase, but a trip charge will apply. This charge will be waived if you transport the product to an authorized Craftsman drop-off location. For the nearest authorized location, call 1-800-4-MY-HOME®.

Tractor warranty coverage does not include:

- Expendable items which become worn during normal use, including but not limited to blades, spark plugs, air cleaners, belts, and oil filters.
- Standard maintenance servicing, oil changes, or tune-ups.
- Tire replacement or repair caused by punctures from outside objects, such as nails, thorns, stumps, or glass.
- Repairs necessary because of operator abuse, including but not limited to damage caused by towing objects beyond the capability of the tractor, impacting objects that bend the frame or crankshaft, or over-speeding the engine.
- Repairs necessary because of operator negligence, including but not limited to electrical and mechanical damage caused by improper storage, failure to use the proper grade and amount of engine oil, failure to keep the deck clear of flammable debris, or failure to maintain the equipment according to the instructions contained in the operator's manual.
- Engine (fuel system) cleaning or repairs necessary because of fuel determined to be contaminated or oxidized (stale). In general, fuel should be used within 30 days of its purchase date.
- Normal deterioration and wear of the exterior finishes, or product label replacement.
- The tractor battery, which is covered for only 90 days as stated below.

### **90-DAYS ON BATTERY**

For ninety (90) days from the date of purchase, if the battery included with this tractor is defective in material or workmanship (our testing proves it will not hold a charge), it will be replaced free of charge.

During the first 30 days of purchase, there will be no charges to replace the battery in your home. For your convenience, in-home warranty service will still be available after the first 30 days of purchase, but a trip charge will apply. This charge will be waived if you transport the battery to an authorized Craftsman drop-off location. For the nearest authorized location, call 1-800-4-MY-HOME®.

All tractor and battery warranty coverage is void if this product is used for commercial or rental purposes.

This warranty applies only while this product is within the United States.

This warranty gives you specific legal rights, and you may also have other rights, which vary, from state to state.

**Sears, Roebuck and Co., Dept. 817WA, Hoffman Estates, IL 60179**

**CRAFTSMAN®**