

REPAIR PARTS MANUAL
MODEL NO. 274240
Lawn Tractor

20.0 hp Kohler 42" hydro

2006

CRAFTSMAN®

HOW TO USE THIS MANUAL

This manual is designed to provide the customer with a means to identify the parts on his/her tractor when ordering repair parts. The illustrations may or may not represent the actual assemblies; therefore, it is not recommended to use this manual as a guide to assemble or disassemble the tractor. Some hardware and parts are drawn larger in order to more readily identify them.

Each tractor has its own model number.

The model number for your tractor can be found on the fender under the seat.

When ordering parts, always give the following information:

- Product - "Tractor"
- Model Number - "274240"
- Part Number
- Part Description

TABLE OF CONTENTS

SCHEMATIC	3
ELECTRICAL.....	4-5
CHASSIS.....	6-7
DRIVE.....	8-9
STEERING	10-11
ENGINE.....	12
MOWER LIFT.....	13
SEAT	14
DECALS.....	15
MOWER DECK	16-17
TRANSAXLE.....	18-19
ENGINE BREAKDOWN.....	20-25
WARRANTY.....	24

TRACTOR- -MODEL NO. 917. 274240

SCHEMATIC

03054 (197428)

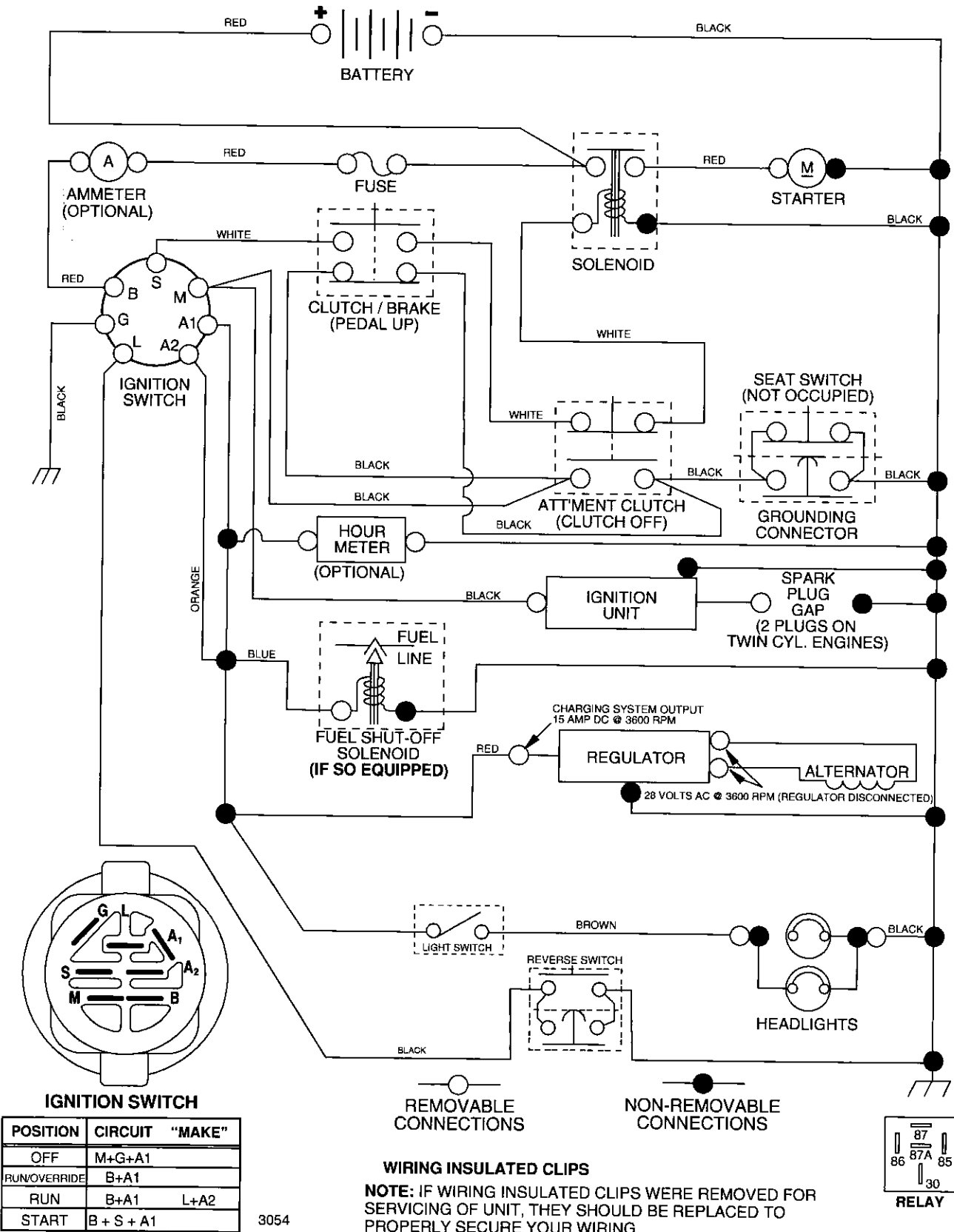

REPAIR PARTS

TRACTOR- -MODEL NO. 917. 274240

ELECTRICAL

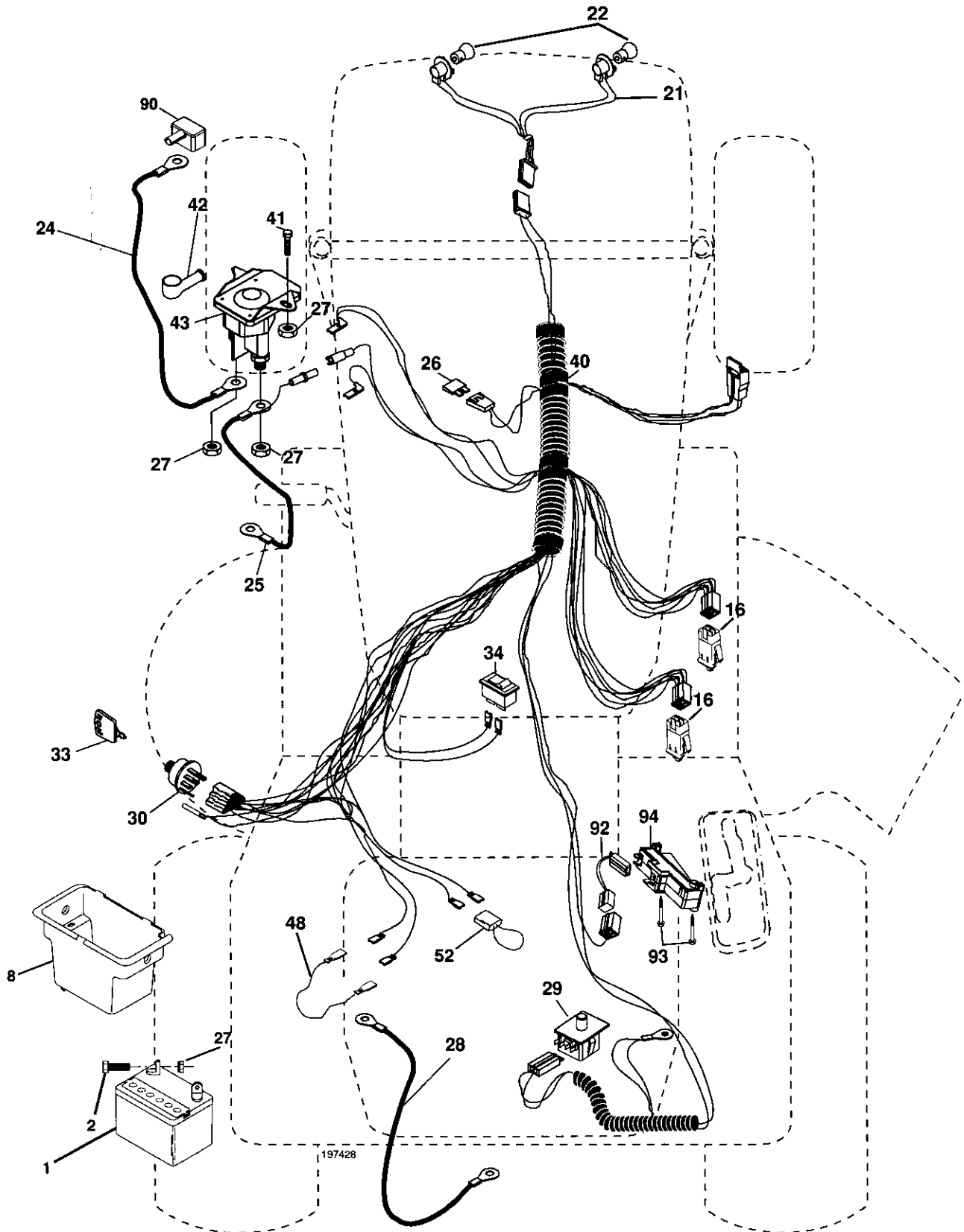

REPAIR PARTS

TRACTOR- -MODEL NO. 917. 274240

ELECTRICAL

KEY NO.	PART NO.	DESCRIPTION
1	144927	Battery
2	74760412	Bolt Hex Hd 1/4-20 unc x 3/4
8	176689	Box Battery
16	176138	Switch, Interlock
21	183759	Harness Asm Light W/4152j
22	4152J	Bulb Light #1156
24	4799J	Cable Battery 6 Ga. 11" red
25	146147	Cable Battery
26	175158	Fuse
27	73510400	Nut Keps Hex 1/4-20 Unc
28	4207J	Cable Ground 6 Ga. 12" black
29	192749	Switch Seat DP w/ROS
30	193350	Switch Ign
33	140403	Key Ign
34	110712X	Switch Light
40	194728	Harness Ign
41	71110408	Bolt Blk. Fin Hex 1/4-20 unc x 1/2
42	131563	Cover Terminal Red
43	192507	Solenoid
48	140844	Adapter Ammeter
52	141940	Protection Wire Loop
90	180449	Cover Terminal
92	196615	Harness Pigtail
93	192540	Screw Plastic 10-14 x 2.0
94	191834	Module Reverse ROS

NOTE: All component dimensions given in U.S. inches
1 inch = 25.4 mm

REPAIR PARTS

TRACTOR- -MODEL NO. 917. 274240

CHASSIS AND ENCLOSURES

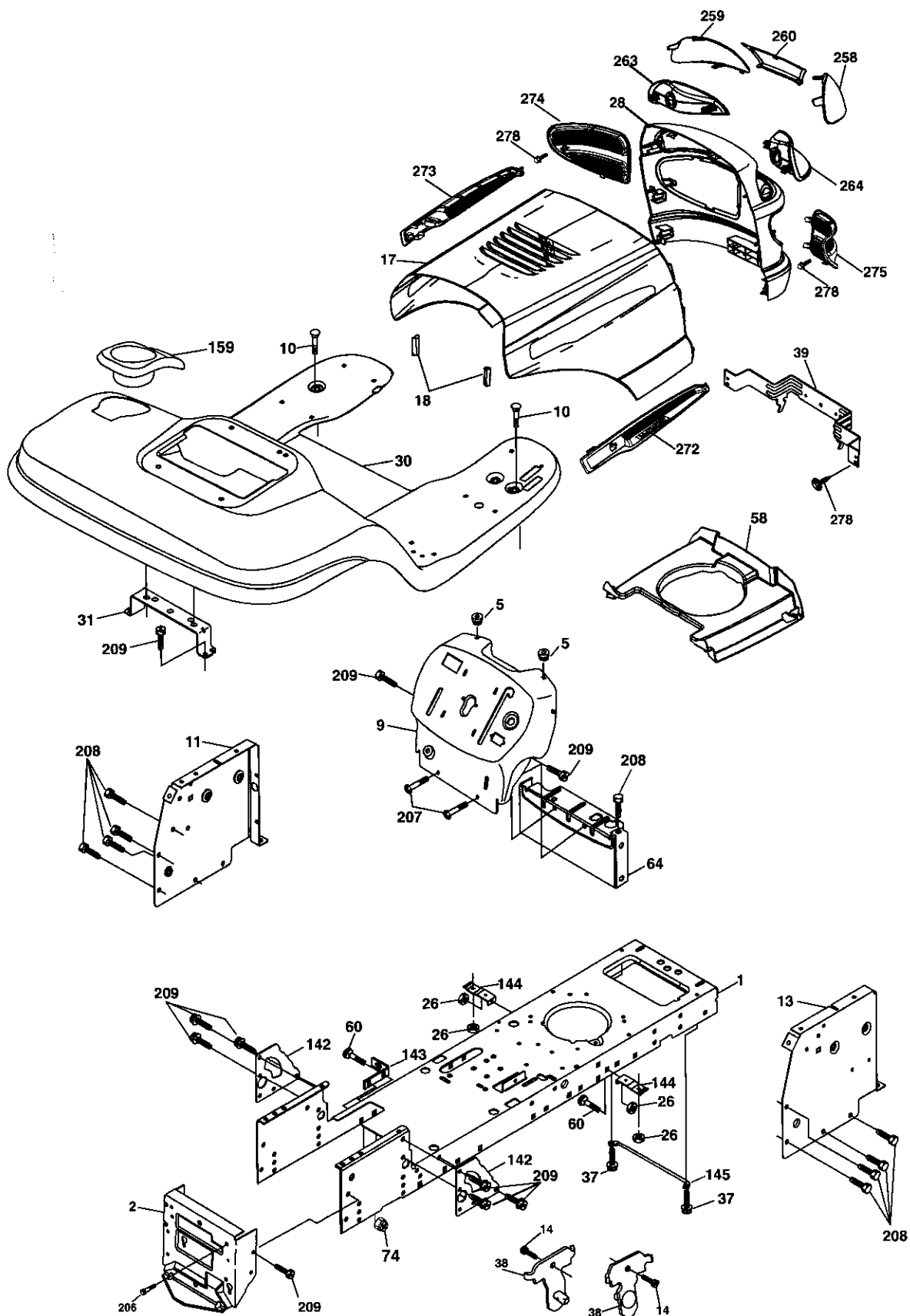

chassis-Laser -lt.stlt_46

REPAIR PARTS

TRACTOR- -MODEL NO. 917. 274240

CHASSIS AND ENCLOSURES

KEY NO.	PART NO.	DESCRIPTION
1	174619	Chassis
2	176554	Drawbar
5	155272	Bumper Hood/Dash
9	193510X013	Dash
10	STD533710	Bolt, Carriage 3/8-16 x 1
11	174996	Panel, Dash, L.H.
13	172105X010	Panel, Dash, R.H.
14	17490608	Screw Thdrol 3/8-16 x 1/2
17	184272X615	Hood Assembly
18	184921	Bumper Hood
26	STD541437	Nut
28	184259	Grille/Lens Asm. (Includes Key Nos. 29 and 212)
30	192393X615	Fend/Ftrest
31	139976	Bracket, Fender Support
37	17490508	Screw Thdrol 5/16-18 x 1/2
38	175710	Pivot Bracket Assembly, Rear
39	174714	Bracket Pivot Laser Lt
58	187154	Duct Air
60	72140606	Bolt Rdhd Sqnk 3/8-16 unc x 3/4
64	154798	Dash Lower STLT
74	STD541437	Nut Crownlock 3/8-16 unc
142	175702	Plate Reinforcement STLT
143	186689	Bracket Swaybar Chassis
144	175582	Bracket Pnt Footrest STLT
145	156524	Rod Pivot Chassis/Hood
159	155123X428	Cupholder Stlt Black
206	170165	Bolt Shoulder 5/16-18 TT
207	17670508	Screw Thdrol 5/16-18 x 1/2 Tytt
208	17670608	Screw Thdrol 3/8-16 x 1/2
209	17000612	Screw Hexwsh Thdr 3/8-16 x 3/4
258	184264X599	Lens RH Laser
259	184263X599	Lens LH Laser
260	184262X428	Cover Lens Laser
263	184265	Bezel Grille Laser LH
264	184266	Bezel Grille Laser RH
272	185925X428	Vent Hood Laser RH
273	185924X428	Vent Hood Laser LH
274	184260X428	Insert Grille Laser LH
275	184261X428	Insert Grille Laser RH
278	191611	Screw 10 x 3/4 Single Lead-Hex
--	5479J	Plug, Button

NOTE: All component dimensions given in U.S. inches
1 inch = 25.4 mm

REPAIR PARTS

TRACTOR--MODEL NO. 917. 274240

DRIVE

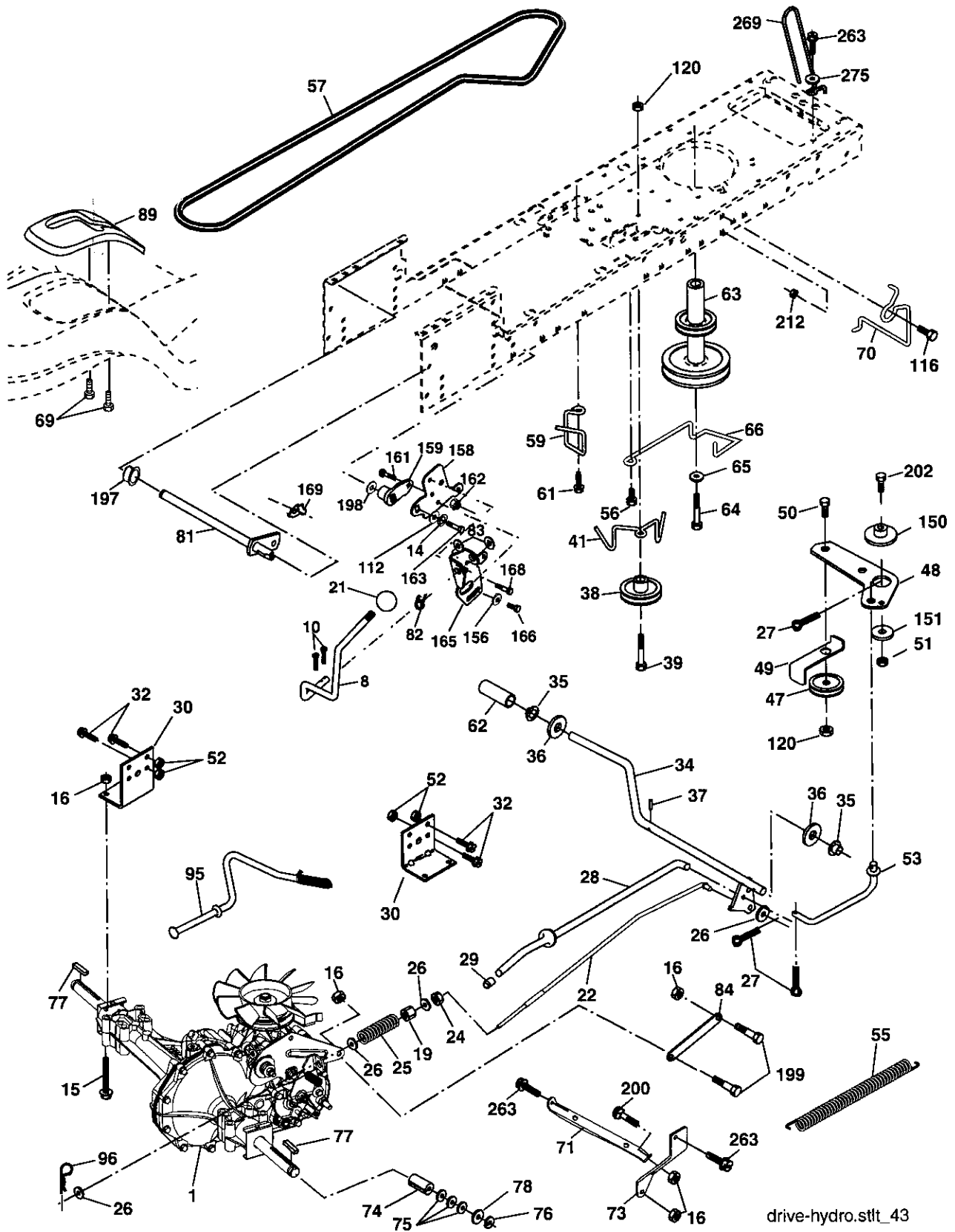

drive-hydro.sttt_43

REPAIR PARTS

TRACTOR- -MODEL NO. 917. 274240

DRIVE

KEY NO.	PART NO.	DESCRIPTION	KEY NO.	PART NO.	DESCRIPTION
1	-----	Transmission (See Breakdown) Hydro Gear Model 314-0510	70	180218	Guide, Belt, Mower Drive RH
8	192502	Rod, Shift	71	169183	Strap, Torque, Lh
10	STD561210	Pin, Cotter 1/8 x 1	73	169182	Strap, Torque, Rh
14	STD551125	Washer Lock 1/4	74	137057	Spacer, Axle
15	74490544	Bolt Hex Flghd 5/16-18 Gr. 5	75	121749X	Washer 25/32 x 1-1/4 x 16 Ga.
16	73800500	Nut, Lock Hex w/Ins 5/16-18 unc	76	12000001	Ring, E
19	73800600	Nut Lock Hex w/Ins 3/8-16	77	123583X	Key, Square
21	130564	Knob	78	121748X	Washer 25/32 x 1-5/8 x 16 Ga.
22	169498	Rod, Brake	81	165596	Shaft Asm Cross
24	73350600	Nut	82	165711	Spring, Torsion
25	106888X	Spring, Rod, Brake	83	19171216	Washer 17/32 x 3/4 x 16 Ga.
26	19131316	Washer 13/32 x 13/16 x 16 Ga.	84	169594	Link Transaxle
27	STD561210	Pin, Cotter 1/8 x 3/4	89	192387X428	Console, Shift
28	175765	Rod, Parking Brake	95	170201	Control Asm Bypass Hydro
29	71673	Cap, Parking Brake	96	STD624003	Spring, Retainer 1"
30	169592	Bracket, Transmission	112	19091210	Washer 9/32 x 3/4 x 10 Ga.
32	74760512	Bolt Hex 5/16-18 unc x 3/4	116	72140608	Bolt Rdhd Sq Neck 3/8-16 x 1
34	175578	Shaft, Foot Pedal	120	73900600	Nut Lock Flg 3/8-16
35	120183X	Bearing, Nylon	150	175456	Spacer Retainer
36	19211616	Washer	151	19133210	Washer 13/32 x 2 x 10
37	1572H	Pin, Roll	156	166002	Washer 5/16 x 1.0 x 1.25
38	179114	Pulley, Composite	158	165589	Bracket Shift Mount
39	72110622	Bolt	159	183900	Hub Tapered Flange Shift
41	175556	Keeper, Belt, Idler	161	72140406	Bolt Rdhd Sqnk 1/4-20 x 3/4 Gr. 5
47	127783	Pulley, Idler, V-Belt	162	73680400	Nut Crownlock 1/4-20 unc
48	154407	Bellcrank Clutch Grnd Drustl	163	74780416	Bolt Hex Fin 1/4-20 x 1
49	123205X	Retainer, Belt	165	165623	Bracket Pivot Lever
50	72110612	Bolt Carr. Sh 3/8-16 x 1-1/2 Gr. 5	166	17490510	Screw 5/16 x 5/8
51	STD541437	Nut	168	165492	Bolt Shoulder 5/16-18 x .561
52	STD541431	Nut Crownlock 5/16-18	169	165580	Plate Fastener Cross Shaft
53	199652	Link, Clutch	197	169613	Nyliner Snap-In
55	105709X	Spring, Return, Clutch	198	169593	Washer Nyliner
56	17060620	Screw 3/8-16 x 1-1/4	199	169612	Bolt Shoulder 5/16-18 unc
57	140294	V-Belt, Drive	200	72140508	Bolt RdHd Sqnk 5/16-18 unc x 1
59	169691	Keeper, Belt, Center	202	72110614	Bolt Carr. Sh 3/8-16 x 1-3/4 Gr. 5
61	17120614	Screw 3/8-16 x .875	212	145212	Nut Hex Flange Lock
62	8883R	Cover, Pedal	263	17000612	Screw 3/8-16 x 3/4
63	180219	Pulley, Engine	268	182402	Guard Muffler
64	173937	Bolt Hex 7/16 x 20 x 4 x Gr. 5-1.5	275	19131614	Washer 13/32 x 1 x 14 Ga.
65	10040700	Washer			
66	154778	Keeper, Belt Engine Hydro			
69	142432	Screw Hex Wsh Hi-Lo 1/4 x 1/2 unc			

NOTE: All component dimensions given in U.S. inches
1 inch = 25.4 mm

REPAIR PARTS

TRACTOR- -MODEL NO. 917. 274240

STEERING ASSEMBLY

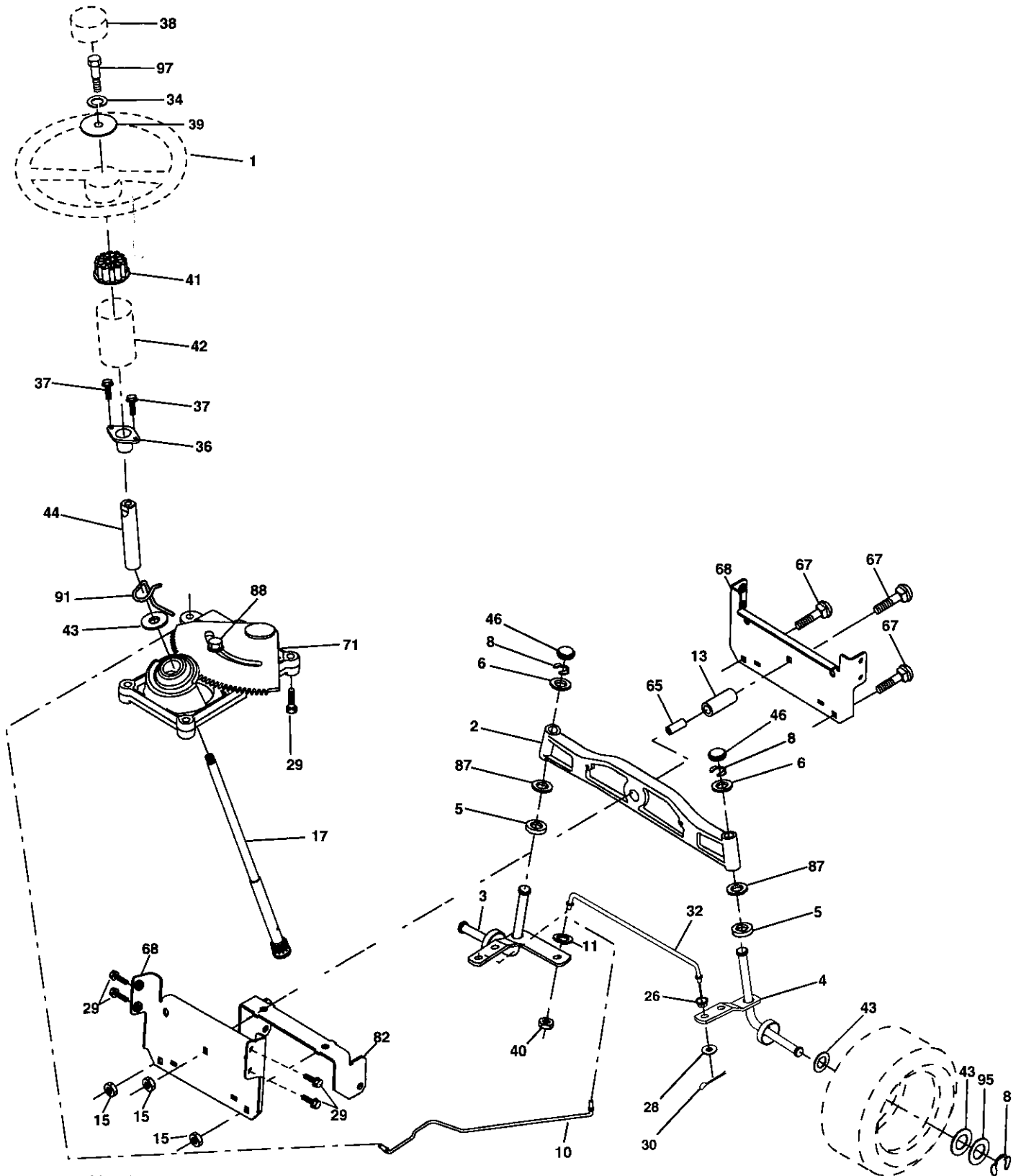

steering_pl.it_57

REPAIR PARTS

TRACTOR- -MODEL NO. 917. 274240

STEERING ASSEMBLY

KEY NO.	PART NO.	DESCRIPTION
1	186093X428	Steering Wheel
2	184706	Axle Assembly Cast Iron
3	169840	Spindle Assembly, L.H.
4	169839	Spindle Assembly, R.H.
5	6266H	Bearing, Race, Thrust, Hardened
6	121748X	Washer 25/32 x 1-5/8 x 16 Ga.
8	12000029	Ring, Klip
10	175121	Draglink
11	STD551137	Washer, Lock
13	136518	Spacer Bearing Axle Front
15	145212	Nut, Hex Flange Lock
17	190753	Shaft, Steering
26	126847X	Bushing, Link, Drag
28	19131416	Washer 13/32 x 7/8 x 16 Ga.
29	17000612	Screw 3/8-16 x 3/4
30	STD561210	Pin Cotter
32	192757	Rod, Tie
34	10040500	Washer Split Hvy Hlcl Spr. 5/16
36	155099	Bushing, Steering
37	152927	Screw
38	186095X428	Insert, Steering Wheel
39	19113812	Washer 11/32 x 2-3/8 12 Ga.
40	73540600	Nut Crownlock 3/8-24
41	186737	Adaptor, Steering Wheel
42	145054X428	Boot, Steering Shaft
43	121749X	Washer 25/32 x 1-1/4 x 16 Ga.
44	190752	Extension Shaft Steering
46	184946X505	Cap, Spindle
65	160367	Spacer Brace Axle
67	72110618	Bolt RDHD Sqnk 3/8-16 x 2-1/4
68	169827	Axle, Brace
71	175146	Steering Asm.
82	199978	Bracket Susp. Chassis Front
87	173966	Washer Flat .781 x 1-1/2 x .14
88	175118	Bolt Shoulder 7/16-20 unc
91	175553	Clip Steering
95	188967	Washer Hardened
97	74780564	Bolt 5/16-18 unc x 4 Gr. 5

NOTE: All component dimensions given in U.S. inches
1 inch = 25.4 mm

REPAIR PARTS

TRACTOR- -MODEL NO. 917. 274240

ENGINE

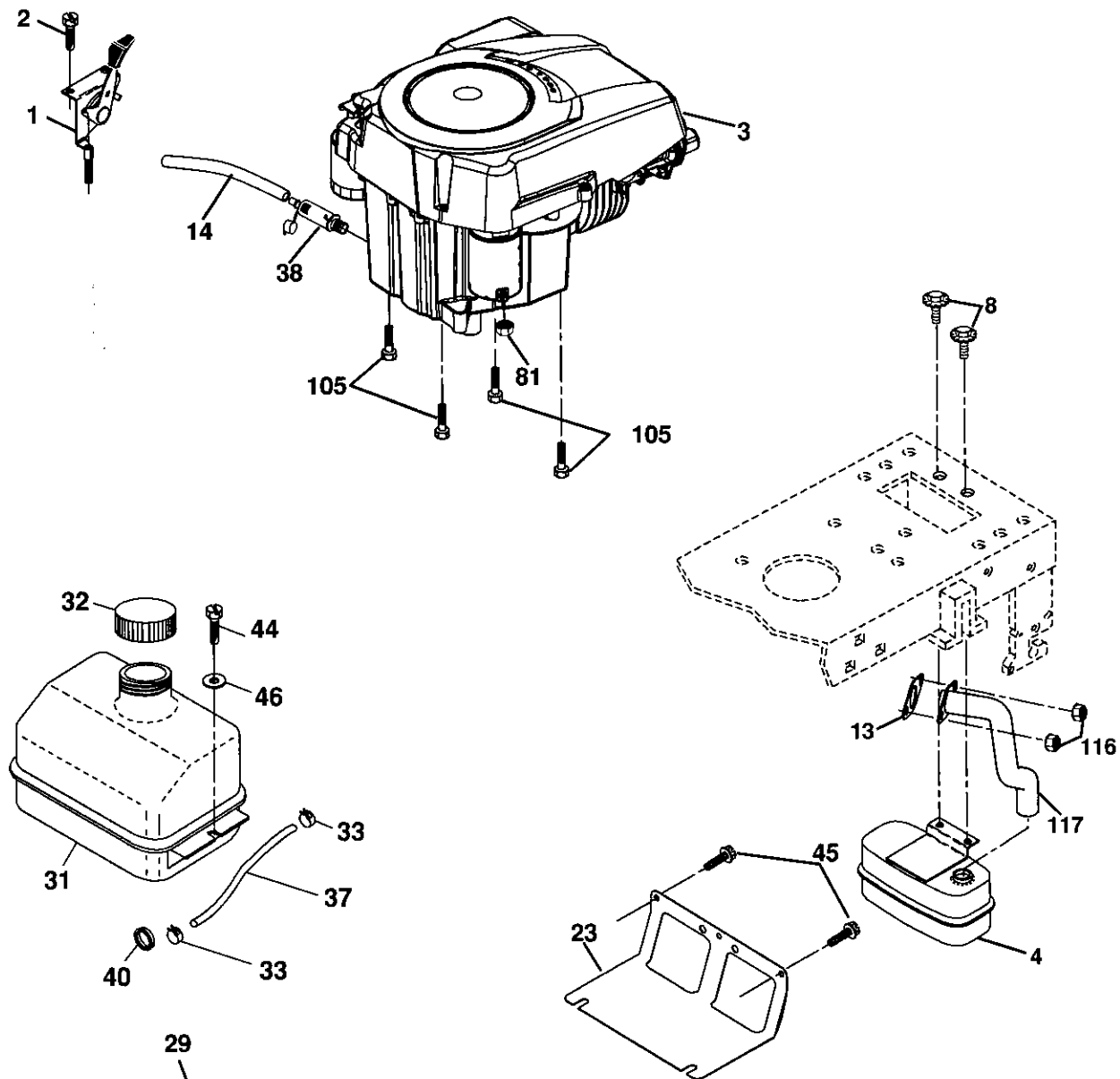

OPTIONAL EQUIPMENT
Spark Arrester

engine-kohler_43

KEY NO.	PART NO.	DESCRIPTION
1	170548	Control, Throttle/Choke
2	17720408	Screw, Hex Head, Thread Cutting 1/4-20 x 1/2
3	-----	Engine, Kohler Model SV600-0021 (See Breakdown)
4	188655	Muffler
8	171877	Bolt 5/16-18 unc x 3/4 w/Sems
13	185909	Gasket
14	148456	Tube Drain Oil Easy
23	169837	Shield Brn/Dbr Guard
29	137180	Arrestor, Spark
31	197766	Tank, Fuel
32	197725	Cap Assembly, Fuel Sears, Vented

KEY NO.	PART NO.	DESCRIPTION
33	123487X	Clamp, Hose
37	137040	Line, Fuel
38	181654	Plug Drain Oil Easy
44	17670412	Screw, Hex Washer Head, Thd., Roll. 1/4-20 x 3/4
45	17000612	Screw Hxwsh Thdr 3/8-16 x 3/4
46	19091416	Washer 9/32 x 7/8 x 16 Ga.
81	73510400	Nut Keps Hex 1/4-20
105	17120616	Screw 3/8-16 x 1
116	184362	Nut Hex Flange Toplock M8-1.25
117	188654	Tube Exhaust

NOTE: All component dimensions given in U.S. inches
1 inch = 25.4 mm

REPAIR PARTS

TRACTOR- -MODEL NO. 917. 274240

MOWER LIFT

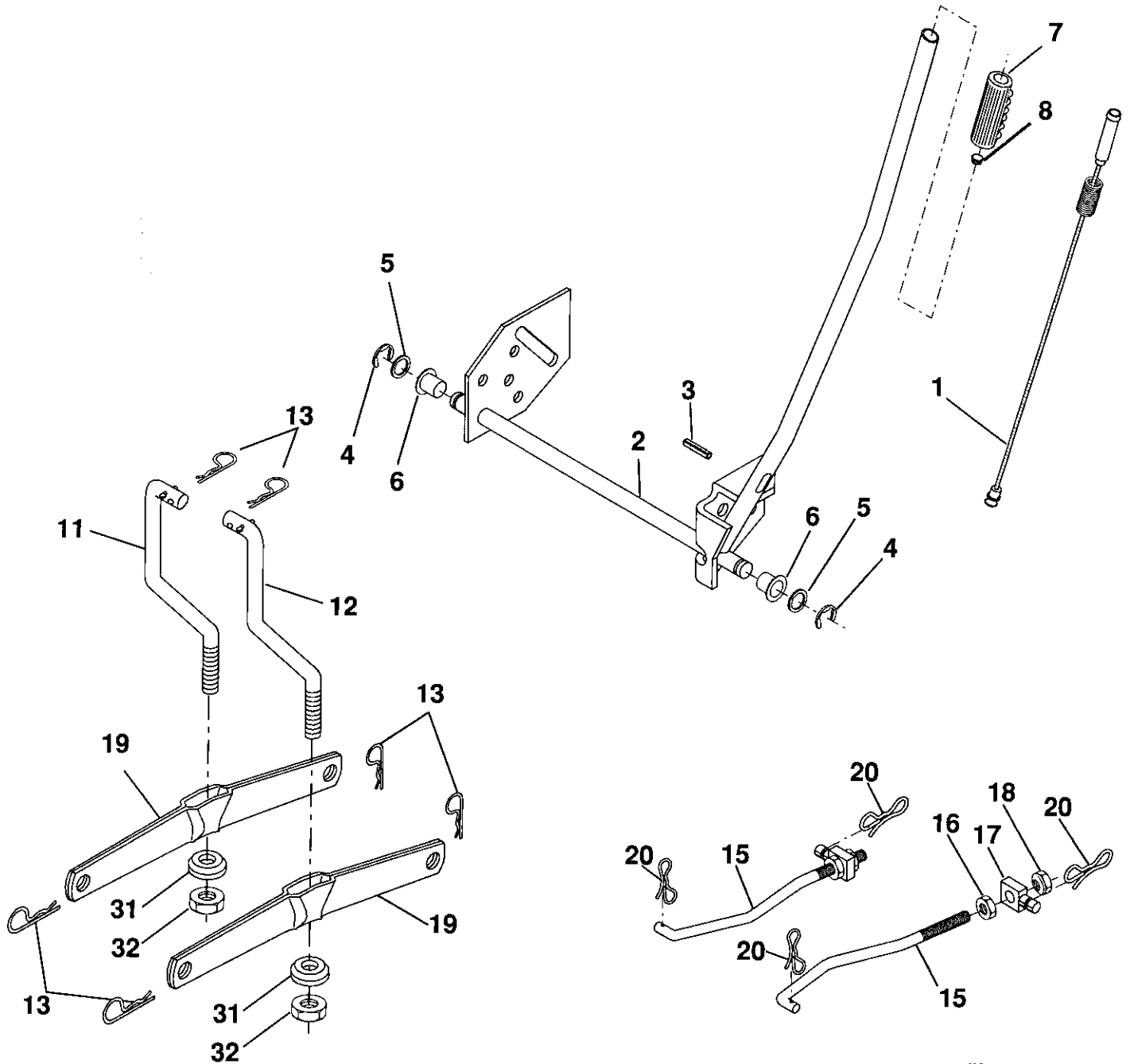

lift-rh.1piece_3

KEY NO.	PART NO.	DESCRIPTION
1	159460	Washer Asm Inner Spring W/ Plunger
2	159471	Shaft Asm. Lift
3	105767X	Pin Groove
4	12000002	E Ring #5133-62
5	19211621	Washer 21/32 x 1 x 21 Ga.
6	120183X	Bearing Nylon
7	125631X	Grip Handle Fluted
8	122365X	Button Plunger Read
11	139865	Link Asm Lift L.H.
12	139866	Link Asm Lift R.H.
13	STD624008	Retainer Spring

KEY NO.	PART NO.	DESCRIPTION
15	173288	Link Front
16	73350800	Nut Jam Hex 1/2-13 unc
17	175689	Trunnion Blk Zinc
18	73800800	Nut Lock w/Wsh 1/2-13 unc
19	139868	Arm Suspension Mower
20	194209	Pin Cotter 7/16 Bow Tie Lock
31	169865	Bearing, Pvt. Lift
32	73540600	Nut Crownlock 3/8-24

NOTE: All component dimensions given in U.S. inches
1 inch = 25.4 mm

REPAIR PARTS

TRACTOR- -MODEL NO. 917. 274240

SEAT ASSEMBLY

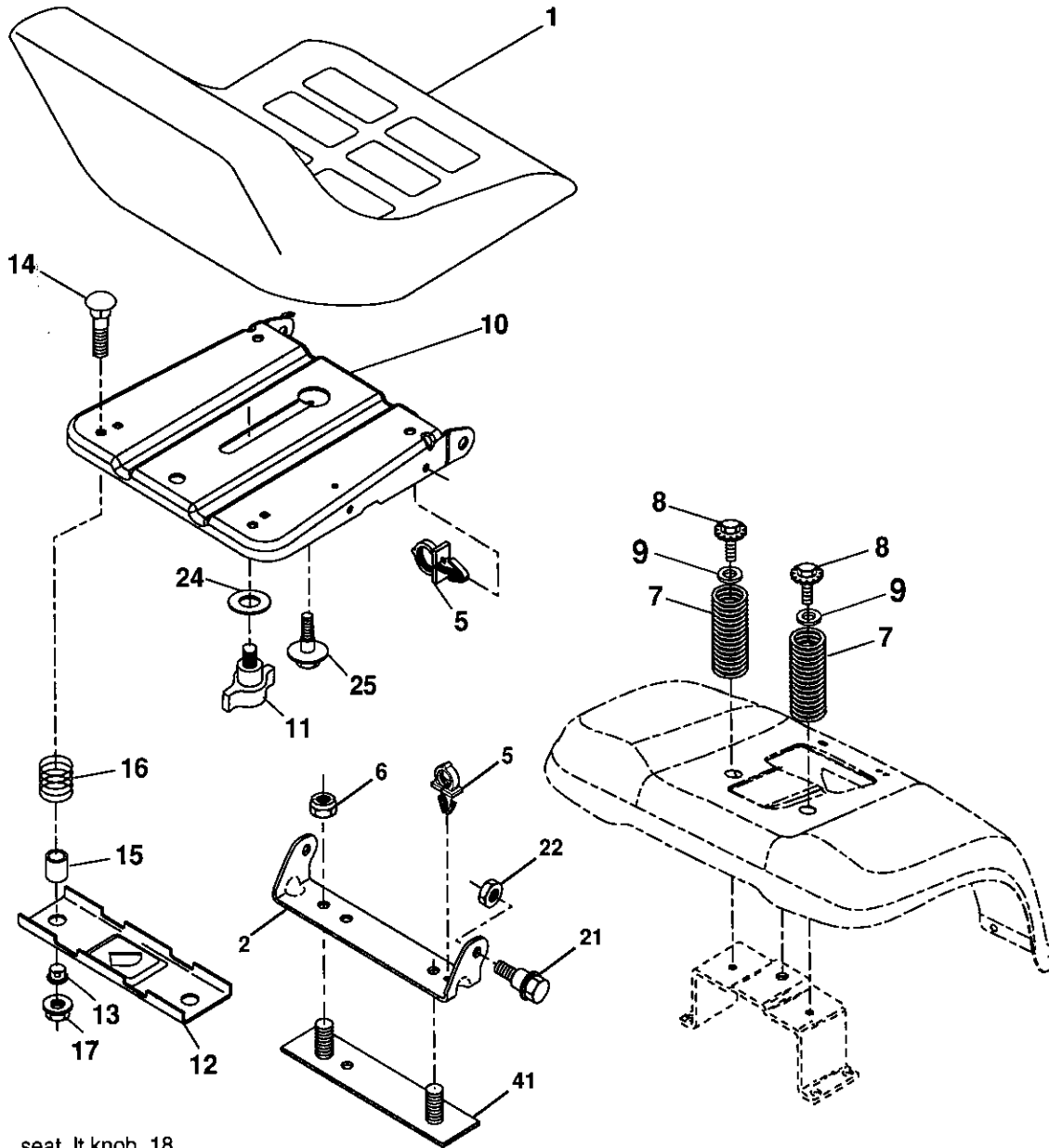

seat_lt.knob_18

KEY NO.	PART NO.	DESCRIPTION	KEY NO.	PART NO.	DESCRIPTION
1	188719	Seat	15	134300	Spacer Split 28 x 96 Zinc
2	140551	Bracket Pivot Seat	16	121250X	Spring Cprsn 1 27 Blk Pnt
5	145006	Clip Push In Hinged	17	123976X	Nut Lock 1/4 Lge Flg Gr. 5 Zinc
6	STD541437	Nut Hex Lock w/Ins 3/8-16 unc	21	171852	Bolt Shoulder 5/16-18 unc-2A
7	124181X	Spring Seat Cprsn 2 250 Blk Zi	22	STD541431	Nut Hex Lock w/Ins 5/16-18
8	17000616	Screw 3/8-16 x 1	24	19171912	Washer 17/32 x 1-3/16 x 12 Ga.
9	19131614	Washer 13/32 x 1 x 14 Ga.	25	127018X	Bolt Shoulder 5/16-18 x .62
10	195530	Pan Asm. Seat	41	140675	Strap Asm. Fender
11	166369	Knob Seat Adj Wingnut			
12	174648	Bracket Pnt Mounting Switch			
13	121248X	Bushing Snap Blk Nyl 50 Id			
14	72050412	Bolt Rdhd Sht Nk 1/4-20 x 1-1/2			

NOTE: All component dimensions given in U.S. inches
1 inch = 25.4 mm

REPAIR PARTS

TRACTOR- -MODEL NO. 917. 274240

DECALS

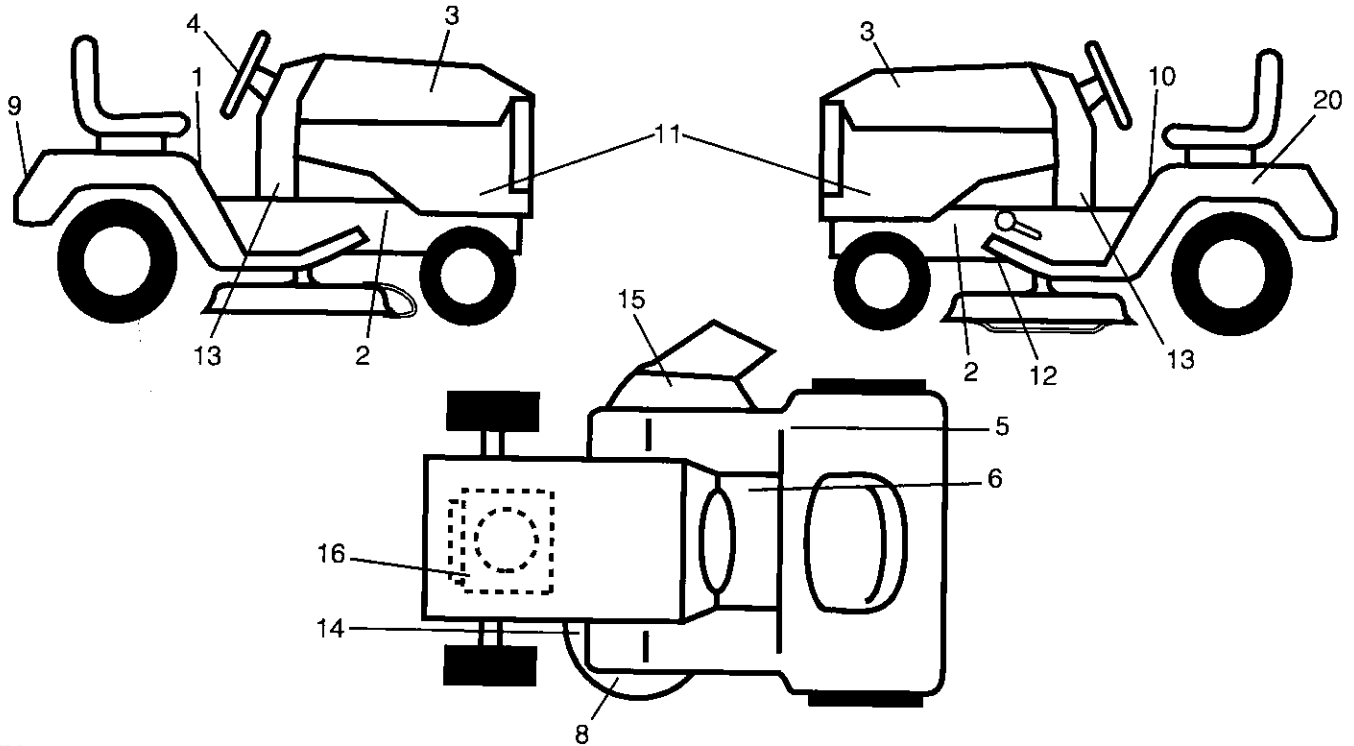

KEY NO.	PART NO.	DESCRIPTION
1	400389	Decal, Warning Syms. CE
2	159736	Decal, Chassis Hot Muffler
3	186366	Decal, Hood
4	164065	Decal, Steering Wheel
5	180432	Decal, Fender
6	140837	Decal, Saddle Brake Parking
8	182166	Decal, Cutfinger CE
9	403259	Decal, Fender
10	159737	Decal, Brake/Clutch
11	404432	Decal, Panel Side
12	197490	Decal, V-Belt Drive Schematic
13	404078	Decal, Chassis
14	160396	Decal, V-Belt Schematic

KEY NO.	PART NO.	DESCRIPTION
15	196357	Decal, Deflect Wrn Cutfinger Sym
16	196841	Decal, Warning Eng. Syms.
20	145005	Decal Battery Dngr/Psn Eng
--	138311	Decal, Lift Handle
--	166960	Decal, Drawbar Load Limit
--	162598	Drawbar Load
--	184310X428	Pad, Footrest LH STLT
--	184311X428	Pad, Footrest RH STLT
--	404870	Manual, Operator's (Euro)
--	404871	Manual, Operator's (Scan)
--	404872	Manual, Operator's (EBloc)
--	404873	Manual, Operator's (Baltic)
--	404874	Manual, Parts

WHEELS & TIRES

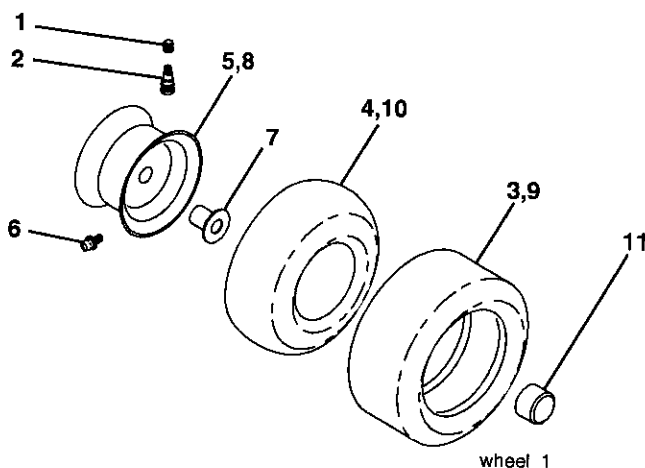

KEY NO.	PART NO.	DESCRIPTION
1	59192	Cap Value Tire
2	65139	Stem Value
3	106222X	Tire F Ts 15 x 6.0 - 6 Service
4	59904	Tube Inner Front #35060
5	106732X643	Rim Asm 6" front Service
6	278H	Fitting Grease
7	9040H	Bearing Flange
8	106108X643	Rim Asm 8" rear Service
9	138468	Tire R Ts 20 x 8-8 Service
10	7152J	Tube Rear 9.5 x 8 Service
11	104757X643	Cap Axle Blk 1 50 x 1 00
--	144334	Sealant, Tire (10 oz. tube)

NOTE: All component dimensions given in U.S. inches
1 inch = 25.4 mm

REPAIR PARTS

TRACTOR- -MODEL NO. 917. 274240

MOWER

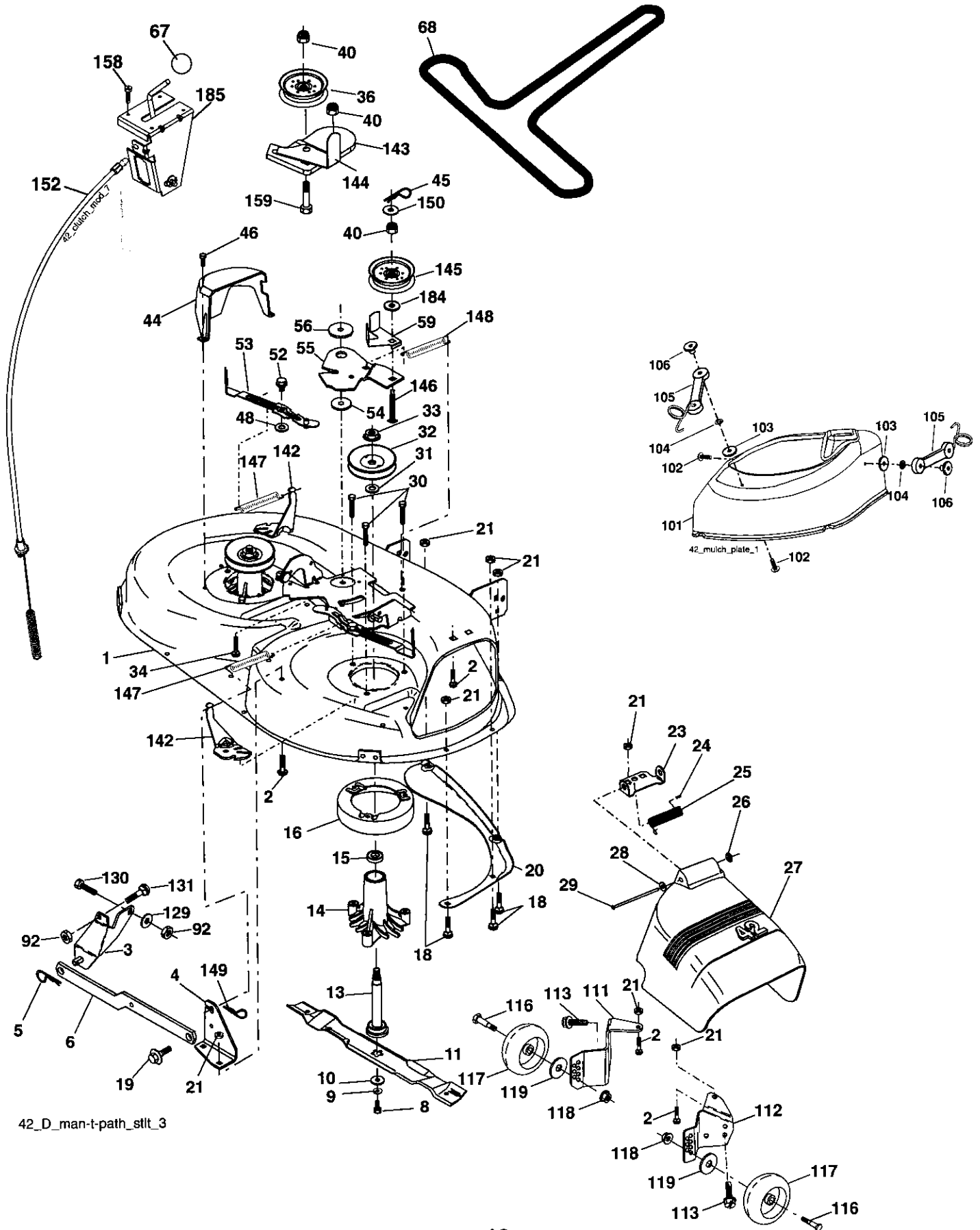

42_D_man-t-path_sllt_3

REPAIR PARTS

TRACTOR- -MODEL NO. 917. 274240

MOWER

KEY NO.	PART NO.	DESCRIPTION	KEY NO.	PART NO.	DESCRIPTION
1	165892	Mower Deck Assembly, 42"	68	180215	V-Belt
2	STD533107	Bolt	92	STD541437	Nut
3	138017	Bracket Assembly,Sway Bar, Front	101	193107	Cover Mulching
4	165460	Bracket Sway Bar 38/42" Deck	102	71081010	Screw Pan Hd Phillips 10-24 x 5/8
5	STD624008	Retainer Spring	103	19061216	Washer # 10
6	178024	Bar Sway Deck	104	10071000	Washer Lock #10
8	850857	Bolt, Hex 3/8-24 x 1.25 Gr. 8	105	160793	Latch Asm. Mulch/Bagger
9	STD551137	Washer, Lock	106	2029J	Nut Weld .327/.304 #10-24
10	140296	Washer, Hardened	111	179292	Bracket Gauge Wheel Lh
11	134149	Blade, 42" Mulching Std (For mulching mowers only)	112	179293	Bracket Gauge Wheel Rh
13	137645	Shaft Assembly, Mandrel, Vented	113	17000510	Screw 5/16-18 unc
14	128774	Housing, Mandrel, Vented	116	4898H	Bolt Shoulder
15	110485X	Bearing, Ball, Mandrel	117	188606	Wheel Gauge
16	174493	Stripper, Vented Mower Deck	118	73930600	Nut Centerlock 3/8-16 unc
18	72140505	Bolt, Carriage 5/16-18 x 5/8	119	19121414	Washer 3/8 x 7/8 x 4 Ga.
19	132827	Bolt, Shoulder	129	19131312	Washer 13/32 x 13/16 x 12 Ga.
20	159770	Baffle, Vortex	130	STD523710	Bolt, Fin Hex 3/8-16 unc x 1 Gr. 5
21	STD541431	Nut Crownlock 5/16-18 unc	131	STD533710	Bolt, Rdhd Sqnk 3/8-16 unc x1
23	177563	Bracket, Deflector	142	165890	Arm Spring Brake Mower
24	105304X	Cap, Sleeve	143	157109	Bracket Arm Idler 42"
25	123713X	Spring, Torsion, Deflector	144	158634	Keeper Belt 42" Clutch Cable
26	110452X	Nut, Push	145	165888	Pulley Idler Flat
27	130968X428	Shield, Deflector	146	171977	Bolt Carriage Idler
28	19111016	Washer 11/32 x 5/8 x 16 Ga.	147	179748	Spring Extension
29	131491	Rod, Hinge	148	169022	Spring Return Idler
30	173984	Screw Thdrol Washer Head	149	165898	Retainer Spring Yellow Zinc
31	187690	Washer, Spacer	150	19091210	Washer 9/32 x 3/4 x 10 Ga.
32	153535	Pulley, Mandrel	152	181555	Cable Clutch 42 In
33	400234	Nut, Toplock, Flanged	158	17720408	Screw Hex Thd Cut 1/4-20 x 1/2
34	STD533717	Bolt	159	72140614	Bolt Rdhd Sqk 3/8-16 unc x 3/4
36	131494	Pulley, Idler, Flat	184	19131410	Washer 13/13 x7/8 x 10 Ga.
40	73900600	Nut Lock Flg 3/8-16 unc	185	188234	Head Asm Cable Clutch
44	140088	Guard, Mandrel, L.H.	--	130794	Mandrel Assembly (Includes Housing, Shaft and Shaft Hardware Only - Pulley Not Included)
45	STD624003	Retainer	--	181281	Replacement Mower, Complete (Std. Deck-Order separately gauge wheel components key nos. 116 - 119).
46	137729	Screw, Thd. Roll 1/4-20 x 5/8			
48	133944	Washer, Hardened			
52	139888	Bolt, Shoulder 5/16-18 unc			
53	184907	Arm Assembly, Pad, Brake			
54	178515	Washer, Hardened			
55	155046	Arm, Idler			
56	165723	Spacer, Retainer			
59	141043	Guard, TUV Idler			
67	149846	Knob Custom Oval			

NOTE: All component dimensions given in U.S. inches
1 inch = 25.4 mm

REPAIR PARTS

TRACTOR- -MODEL NO. 917. 274240

HYDROTRANSAXLE - MODEL NUMBER 314-0510

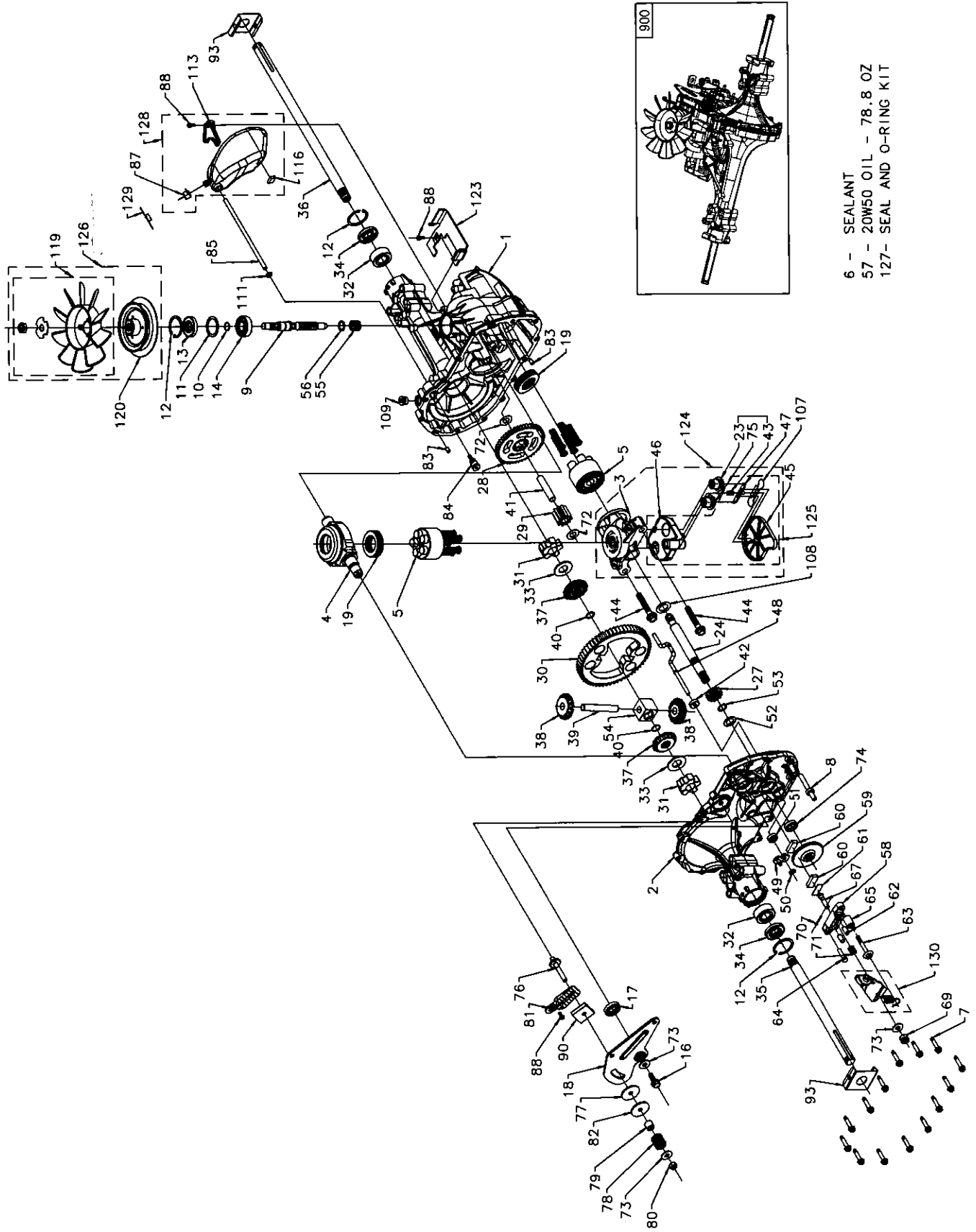

- 6 - SEALANT
- 57 - 20W50 OIL - 78.8 OZ
- 127- SEAL AND O-RING KIT

REPAIR PARTS

TRACTOR- -MODEL NO. 917. 274240

HYDRO TRANSAXLE - MODEL NUMBER 314-0510

KEY NO.	PART NO.	DESCRIPTION	KEY NO.	PART NO.	DESCRIPTION
1	170351	Kit, Main Housing	71	170417	Brake Spring
		Main Housing, Machined	72	170418	Washer (310-0750)
		Bushing .865 X .985 X .790	73	142884	Washer, Flat
2	170352	Kit, Side Housing	74	170419	Seal, Oil
		Side Housing, Machined	75	170420	Ass'y Check Plug
		Bushing .865 X .985 X .790	76	170421	Bolt, Stud 5/16-24
		Bushing .624 X .719 X .562	77	170422	Puck, Friction
3	170353	Kit, Center Section	78	142969	Spring
		Center Section, Machined	79	142980	Spacer
		Bushing .707 X .788 X .591	80	150778	Nut, Nylon Insert Hex Lock 5/16-24
4	170354	Swashplate, Trunnion Machined	81	170423	Wedge, Friction
5	169898	Kit, Cylinder Block (10cc)	82	170424	Clip, Washer
		Block - Cylinder, Piston, Spring, Compression	83	161168	Pin
		Washer Thrust	84	170425	Fitting, 5/16 X Sae 5/32 Tube
6	178322	Sealant Tube	85	170426	Hose, Expansion Tank
7	170356	Hexflange Screw 1/4-20 X 1.25	87	173160	Cap, Vent
8	170357	Stud, 5/16-24 Hex Double End	88	178334	Bolt, Self Tapping (BDR)
9	170358	Shaft, Input	90	170430	Puck, Inner Wedge
10	170359	Retaining Ring	93	170431	Spring Clip, Housing
11	170360	Spacer	107	170432	Deflector
12	169870	Retaining Ring	108	170433	Washer, Motor Shaft
13	170361	Seal, Lip .67 X 1.58 X .276			.71ID X 1.15OD X .03 Thick
14	173158	Bearing, Ball 6203 (BDR)	109	170434	Plug, Straight Thread 9/16-18
16	170362	Hex Flange Head Screw 1/4-20 X 1.25	111	170435	O-ring .7 X .301 ID
17	170363	Seal, Lip 18 X 32 X 7	113	170437	Bracket, Support Expansion Tank
18	170364	Arm, Control	119	191031	Kit, Fan - Washer - Nut
19	173159	Bearing, Thrust (10cc)			Fan, 7 In
23	170365	Check Plug Assembly			Hex Lock Nut 1/2-20 (Nylon Insert)
24	170366	Shaft Motor			Washer, Or Slotted, .53 X 1.63 X .06
27	170367	Gear, Pinion, 13t	120	188312	Pulley
28	170368	10t / 48t Gear	123	178800	Belt Keeper
29	170369	Gear, 10t Jackshaft	124	170444	Kit, Center Section Filter Bypass
30	170370	60t Bullgear			Center Section Machining
31	170371	Sleeve Bearing .75 X 1.75 X .625			Base Filter W/ Poppet
32	170389	Sleeve Bearing (Outboard).75 X 1.575 X .625			Check Plug Assembly, .027 Washer
33	142991	Washer			Check Plug Assembly, Washer
34	170390	Lip Seal, Axle Shaft			Spring, Bypass, Actuator, Bypass
35	170391	Shaft, Axle (Keyed, R.h.)			Deflector, Bottom, Filter
36	170392	Shaft, Axle (Keyed, L.h.)			Bushing, .707 X .788 X .591
37	150792	Gear, Splined Diff. (210-1000 & 310-0750)	125	170445	Kit, Filter
38	150793	Gear, Miter Diff. (210-1000 & 310-0750)			Bottom, Filter
39	150809	Differential Shaft (310-0750)			Spring, Bypass, Actuator, Bypass
40	170393	Retaining Ring			Deflector, Base, Filter W/ Poppet
41	170394	Pin, Jackshaft	126	191028	Kit, Fan/pulley
42	170395	Magnet, Ring			Hex Jam 1/20-20 (Nylon Inser)
43	170396	Spring, Bypass			Washer, OD Slotted, .53 X 1.63 X .06
44	150797	Bolt 3/8-24 X 2-1/2			Fan, 7 In
45	170397	Filter			Pulley
46	170398	Base, Filter	127	170447	Kit, Seal
47	170399	Actuator, Bypass			Lip Seal .67 X 1.58 X .276
48	170400	Rod, Bypass Actuator			Lip Seal 18 X 32 X 7
49	170401	Arm, Bypass			Lip Seal .706 X 1.584 X .25
50	170402	Retaining Ring .25 External			Lip Seal .741 X .250 X .250 Tc
51	170403	Seal, Lip .741 X .25 X .25			Oil Seal .625 X 1.0 X .25
52	170404	Washer, Flat 0.050" (210-1000)			O-ring .07 X .301 ID
53	170405	Retaining Ring	128	173165	Kit, Expansion Tank
54	170406	Bearing, Center Block			Tank, Expansion
55	142977	Spring, Helical Compression			Cap, Vent
56	142978	Washer, Block Thrust			Bolt, Self Tapping 10-32 X 1/2
57	----	20W-50 Oil			Bracket, Support Expansion Tank
58	142929	Kit, Brake Yoke			Silicon Sponge 1/2 X 1/2 X 3/16
59	170408	Rotor, Brake	129	191032	Cap, Expansion Tank Shipping
60	142883	Brake Puck	130	186352	Kit, Brake Arm And Spring
61	142882	Brake Puck Plate			Arm, Brake
62	170409	Pin, Brake Actuating			Spring, Brake Arm Bias
63	170410	Hfhcs 1/4-20 X 2 W/patch, Special Flg			Instruction Sheet
64	142892	Bolt, Nylok	900	166768	Transaxle
65	170411	Spacer, Brake Torsion Spring			
67	170413	Bolt, Square Head - Brake			
69	170415	Nut, Castle 5/16-24			
70	170416	Pin, Cotter 3/32x3/4			

NOTE: All component dimensions given in U.S. inches 1 inch = 25.4 mm

REPAIR PARTS

TRACTOR- -MODEL NO. 917. 274240

KOHLER ENGINE - - MODEL NUMBER SV600, TYPE NUMBER 0021

CYLINDER HEAD, VALVE AND BREATHER

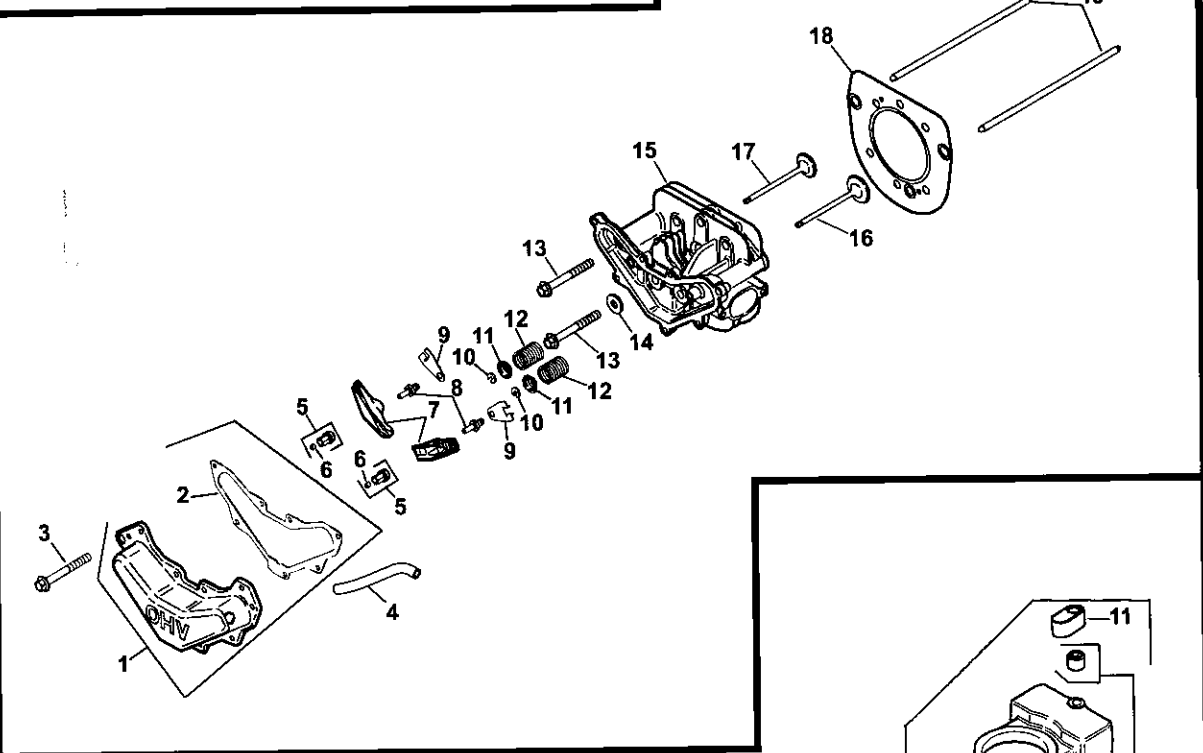

CRANKCASE

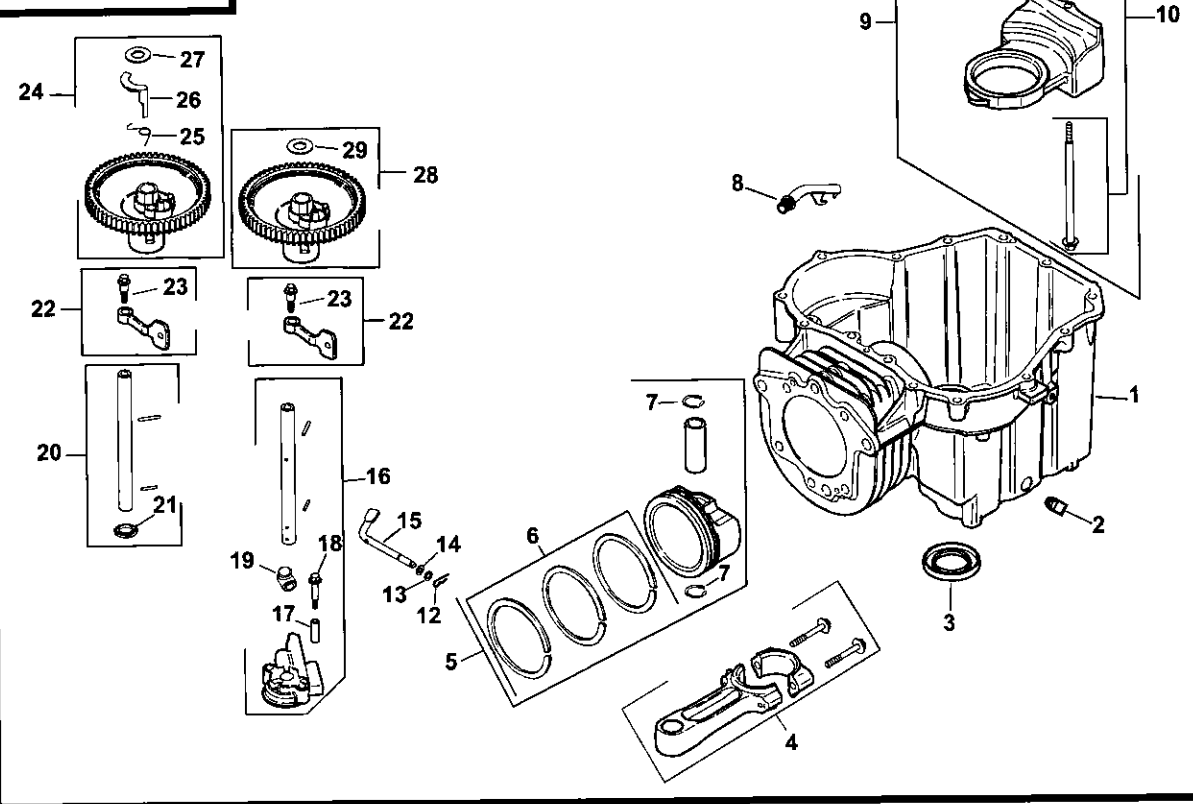

REPAIR PARTS

TRACTOR- -MODEL NO. 917. 274240

KOHLER ENGINE - - MODEL NUMBER SV600, TYPE NUMBER 0021

HEAD/VALVE/BREATHER

KEY NO.	PART NO.	DESCRIPTION
1	20 096 07-S 1	Cover, valve (Includes 2)
2	20 041 13-S 1	Gasket, valve cover
3	M-645020-S 7	Screw, thd frm M6x1.0x20
4	20 326 01-S 1	Hose, breather
5	20 599 02-S 2	Pivot, rocker arm (Includes 6)
6	20 086 04-S 2	Screw, set
7	20 186 01-S 2	Arm, rocker
8	20 086 03-S 2	Stud, rocker
9	20 146 03-S 2	Plate, push rod guide
10	20 062 01-S 2	Lock, retainer
11	20 173 01-S 2	Cap, valve spring
12	20 089 03-S 2	Spring, valve
13	20 086 02-S 6	Screw, flg M10x1.5x80
14	12 468 05-S 1	Washer, flat 13/32"
15	20 318 03-S 1	Head, cylinder assembly
16	20 016 01-S 1	Valve, exhaust
17	20 017 01-S 1	Valve, intake
18	20 841 01-S 1	Kit, cylinder head gasket (Includes 2,13,14)
19	20 411 04-S 2	Rod, push

CRANKCASE

KEY NO.	PART NO.	DESCRIPTION
1	-----	1 Crankcase (USE: Short Block 20 522 01)
2	25 139 57-S 1	1 Plug, sq. hd. pipe 3/8"
3	20 032 01-S 1	1 Seal, oil
4	20 067 04-S 1	1 Rod, connecting
5	20 874 01-S 1	1 Piston w/Ring Set (94 mm) (Includes 6,7)
6	20 108 01-S 1	1 Ring Set (94 mm)
7	20 018 04-S 2	2 Retainer, piston pin
8	20 123 02-S 1	1 Tube, drainback (SERIAL BREAK AFTER 343000001)
9	20 755 04-S 1	1 Kit, balance weight (Includes 10,11)
10	20 380 16-S 1	1 Kit, screw/guide pin
11	20 423 02-S 1	1 Shoe, guide
12	12 154 05-S 1	1 Clip, hitch pin
13	M-631015-S 1	1 Washer, flat 6 mm
14	X-25-102-S 1	1 Washer, flat 1/4"
15	20 144 02-S 1	1 Shaft, governor cross
16	20 393 02-S 1	1 Pump assembly, oil (Includes 17-19) (SERIAL BREAK BEFORE 350759999)
	20 393 02-S 1	1 Pump assembly, oil (Includes 17,18) (SERIAL BREAK AFTER 350760001)
17	20 112 02-S 2	2 Spacer, oil pump screw
18	20 086 13-S 2	2 Screw, oil pump (M5 X 36)
19	20 032 07-S 1	1 Seal, oil pump outlet (SERIAL BREAK BEFORE 350759999)
20	20 144 06-S 1	1 Shaft center, cam - Exhaust (Includes 21)
21	20 468 01-S 1	1 Washer, thrust
22	20 090 01-S 2	2 Lever assembly, cam (Includes 23)
23	20 086 06-S 1	1 Screw, shoulder M5x0.8x36
24	20 010 04-S 1	1 Gear assembly, cam - Exhaust (Includes 25-27)
25	20 089 06-S 1	1 Spring, ACR
26	20 044 16-S 1	1 Weight, ACR
27	20 468 03-S 1	1 Washer, thrust - ACR
28	20 010 04-S 1	1 Gear assembly, cam - Intake (Includes 29)
29	20 468 03-S 1	1 Washer, thrust - ACR

NOTE: All component dimensions given in U.S. inches
1 inch = 25.4 mm

REPAIR PARTS

TRACTOR- -MODEL NO. 917. 274240

KOHLER ENGINE - - MODEL NUMBER SV600, TYPE NUMBER 0021

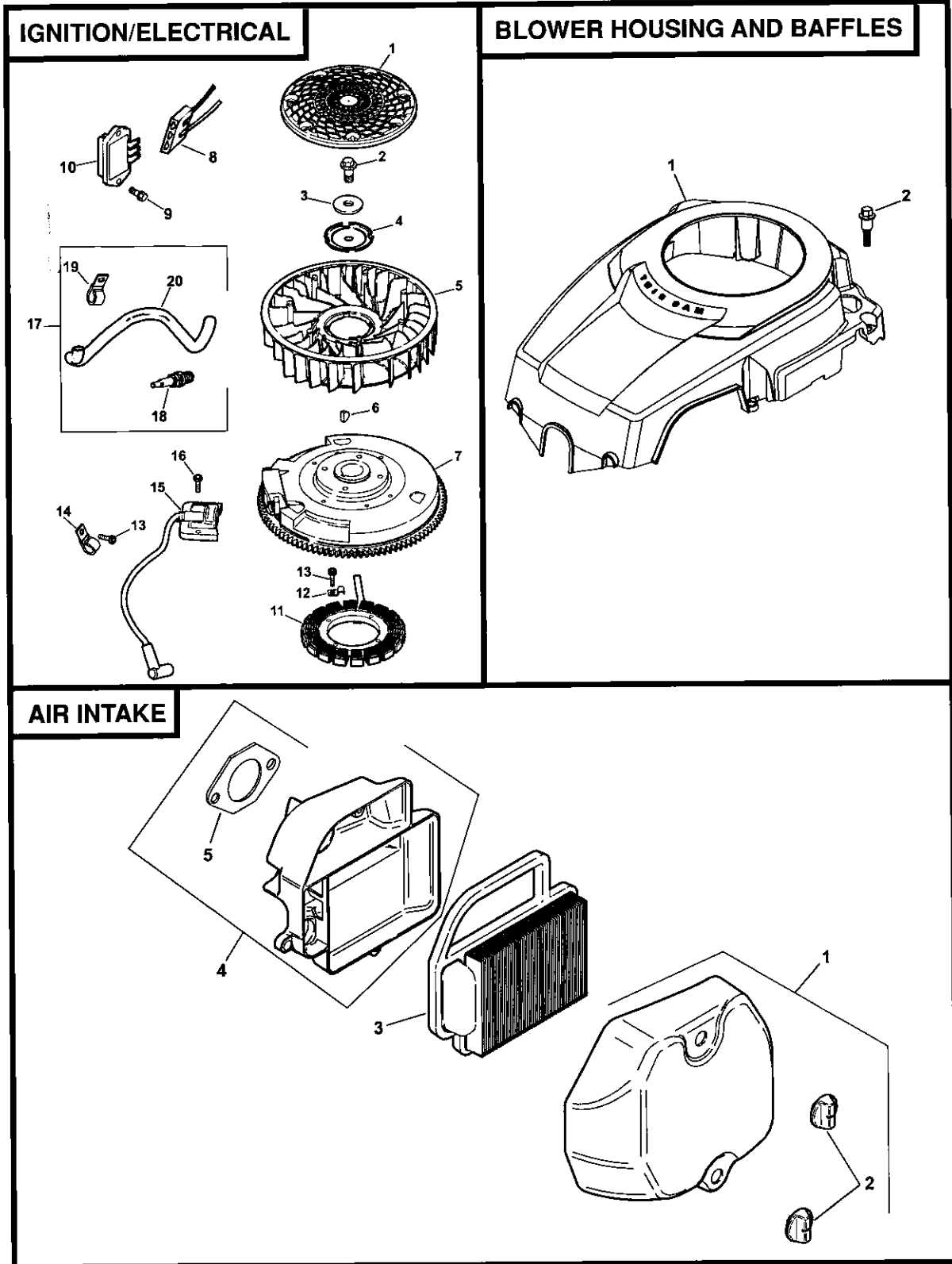

REPAIR PARTS

TRACTOR- -MODEL NO. 917. 274240

KOHLER ENGINE - - MODEL NUMBER SV600, TYPE NUMBER 0021

IGNITION/ELECTRICAL

KEY NO.	PART NO.		DESCRIPTION
1	20 162 02-S	1	Screen, grass
2	12 086 14-S	1	Screw, fig M10x1.5x45
3	12 468 03-S	1	Washer, spring 3/16"
4	20 146 02-S	1	Plate, fan mounting
5	20 157 01-S	1	Fan
6	X-42-15-S	1	Key, 3/16"
7	20 025 05-S	1	Flywheel
8	236602-S	1	Connector, body (3 contact)
9	M-545020-S	2	Screw, fig thd frm m5x0.8x20
10	41 403 09-S	1	Rectifier-regulator
11	237878-S	1	Kit, stator (Includes 25 452 01-S [qnty 2])
12	20 154 03-S	1	Clip, wire
13	20 086 17-S	2	Screw, skt thd frm M5x0.8x25
14	231285-S	2	Clip, cable
15	20 584 01-S	1	Module, ignition
16	M-561025-S	2	Screw, skt thd frm m5x0.8x25
17	20 707 01-S	1	Kit, RFI Suppression (Includes 18-20)
18	20 132 02-S	1	Plug, spark
19	25 154 08-S	1	Clip, cable
20	20 123 01-S	1	Tube, RFI
NOT ILLUSTRATED			
	20 176 01-S	1	Harness, wiring

BLOWER HOUSING & BAFFLES

KEY NO.	PART NO.		DESCRIPTION
1	20 027 06-S	1	Housing, Blower
2	20 086 06-S	1	Screw, Shd Thd Frm M6x1x26

AIR INTAKE/FILTRATION

KEY NO.	PART NO.		DESCRIPTION
1	20 096 04-S	1	Cover, air cleaner (Includes 2)
2	25 341 04-S	2	Knob, cover
3	20 083 02-S	1	Element, air cleaner
4	20 094 01-S	1	Kit, air cleaner base (Includes 5)
5	12 041 02-S	1	Gasket, air cleaner base

NOTE: All component dimensions given in U.S. inches
1 inch = 25.4 mm

REPAIR PARTS

TRACTOR- -MODEL NO. 917. 274240

KOHLER ENGINE - - MODEL NUMBER SV600, TYPE NUMBER 0021

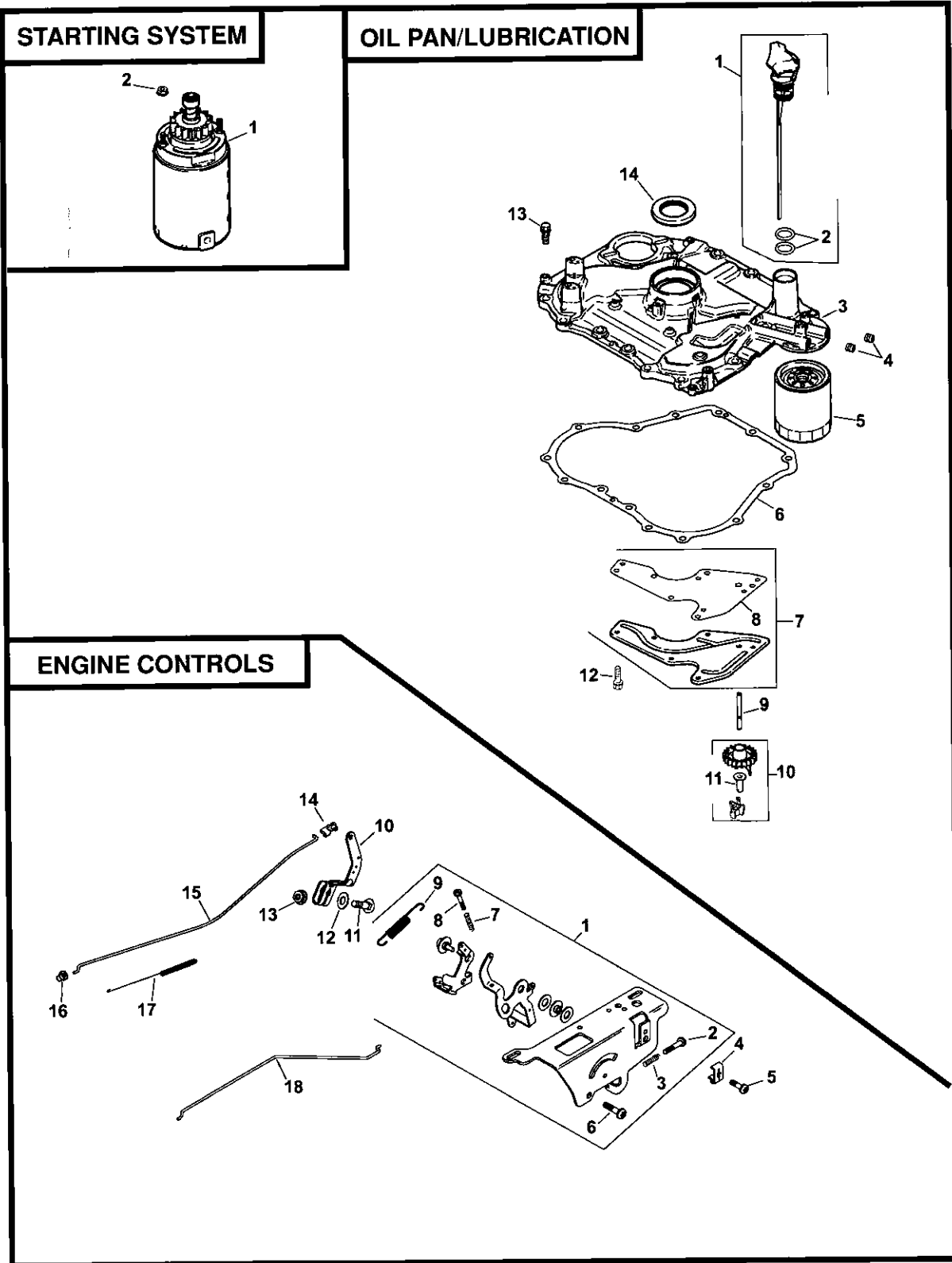

REPAIR PARTS

TRACTOR- -MODEL NO. 917. 274240

KOHLER ENGINE - - MODEL NUMBER SV600, TYPE NUMBER 0021

STARTING SYSTEM

KEY NO.	PART NO.		DESCRIPTION
1	20 098 06-S	1	Starter assembly, inertia drive
2	25 100 31-S	2	Nut, free spinning flg #10-24

OIL PAN/LUBRICATION

KEY NO.	PART NO.		DESCRIPTION
1	20 040 02-S	1	Kit, dipstick assembly (Includes 2)
2	20 153 01-S	2	O-Ring, dipstick
3	20 009 03-S	1	Plate assembly, closure (Includes 4,6-12,14)
4	25 139 60-S	2	Plug, hex ctsk 1/8"
5	52 050 02-S	1	Filter, oil
6	20 041 01-S	1	Gasket, closure plate
7	20 096 02-S	1	Cover, oil passage (Includes 8)
8	20 041 02-S	1	Gasket, oil passage
9	20 144 03-S	1	Shaft, governor gear
10	20 310 03-S	1	Governor Assembly (Includes 11)
11	12 380 01-S	1	Pin, governor regulating
12	M-545013-S	6	Screw, flg thd frm m5x0.8x13
13	M-851030-S	14	Screw, flg m8x1.25x30
14	20 032 01-S	1	Seal, oil

ENGINE CONTROLS

KEY NO.	PART NO.		DESCRIPTION
1	20 536 05-S	1	Control assembly, speed (Includes 2,3,6,7)
2	20 086 10-S	1	Screw, phl thd frm M4x0.7x25
	20 086 18-S	1	Screw, phl thd frm M4x0.7x38
3	12 089 11-S	1	Spring, governor
	20 089 12-S	1	Spring, speed control
4	12 237 01-S	1	Clamp, cable
5	24 086 43-S	1	Screw, lbd thd frm M5x0.8x16
6	M-664020-S	2	Screw, lbd skt M6x1.0x20
7	12 089 11-S	1	Spring, speed control (short)
8	20 086 10-S	1	Screw, thd frm M4x0.7x25
9	20 089 11-S	1	Spring, governor
10	20 090 02-S	1	Lever, governor
11	52 211 04-S	1	Bolt, round head 1/4-20x1"
12	X-22-11-S	1	Washer, lock 1/4"
13	12 100 07-S	1	Nut, hex flg 1/4-20"
14	25 158 11-S	1	Bushing, throttle linkage
15	20 079 04-S	1	Linkage, throttle
16	25 158 08-S	1	Bushing, linkage retaining
17	20 089 10-S	1	Spring, linkage
18	20 079 05-S	1	Linkage, choke - single wire

NOTE: All component dimensions given in U.S. inches
1 inch = 25.4 mm

REPAIR PARTS

TRACTOR- -MODEL NO. 917. 274240

KOHLER ENGINE - - MODEL NUMBER SV600, TYPE NUMBER 0021

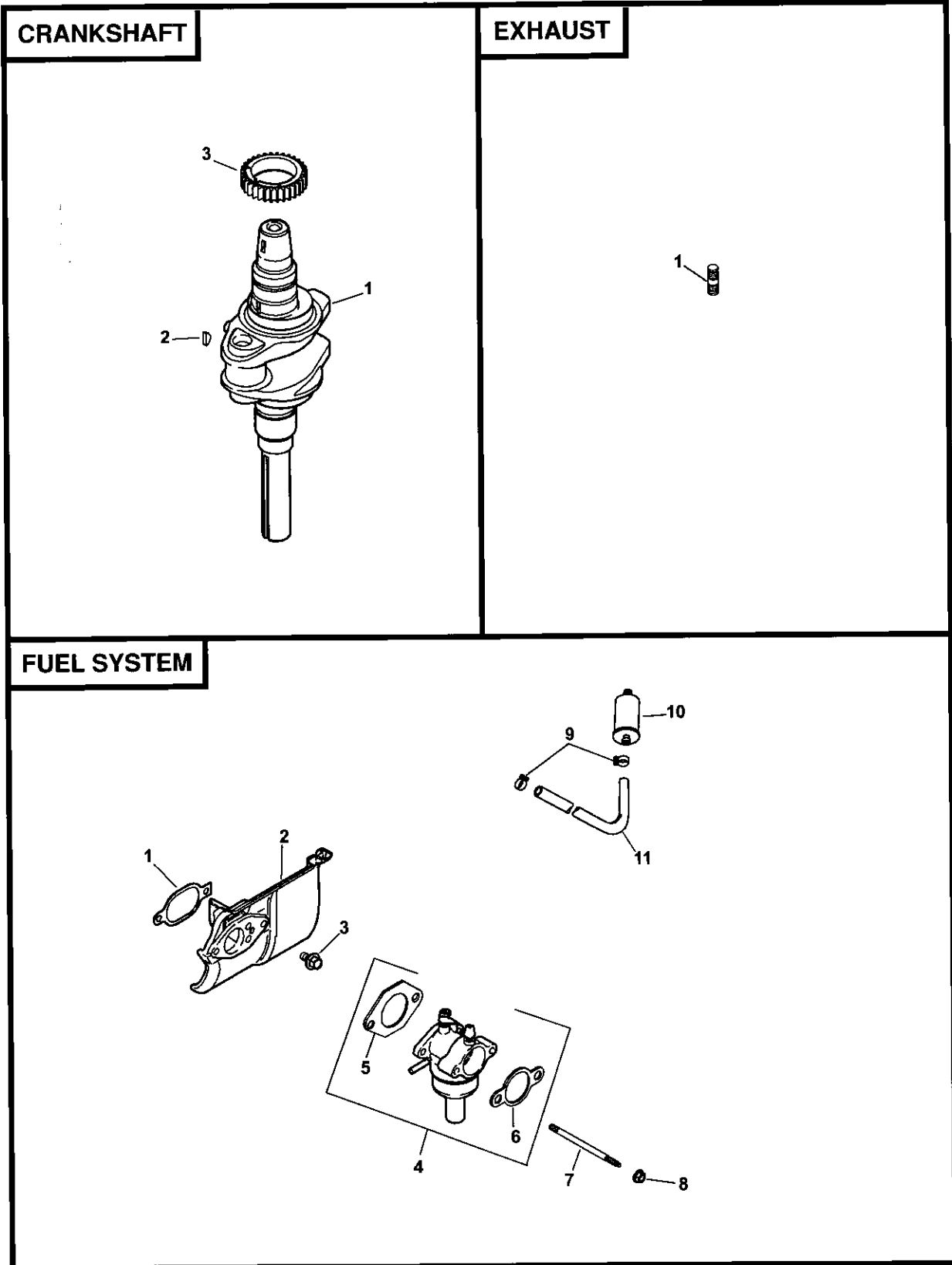

REPAIR PARTS

TRACTOR- -MODEL NO. 917. 274240

KOHLER ENGINE - - MODEL NUMBER SV600, TYPE NUMBER 0021

CRANKSHAFT

KEY NO.	PART NO.		DESCRIPTION
1	20 014 20-S	1	Crankshaft (Includes 2)
2	X-42-15-S	1	Key 3/16"
3	20 043 12-S	1	Gear, crankshaft

EXHAUST

KEY NO.	PART NO.		DESCRIPTION
1	25 072 04-S	2	Stud, exhaust

NOT ILLUSTRATED

20 522 01	1	Short Block
20 755 05-S	1	Gasket Set

FUEL SYSTEM

KEY NO.	PART NO.		DESCRIPTION
1	20 041 07-S	1	Gasket, heat deflector
2	20 265 01-S	1	Deflector, heat
3	M-651020-S	1	Screw, flg M6x1.0x20
4	20 853 21-S	1	Kit, Carburetor (Includes 5,6)
5	12 041 02-S	1	Gasket, air cleaner
6	12 041 01-S	1	Gasket, carburetor
7	20 072 05-S	1	Stud, carburetor mounting
8	M-641060-S	2	Nut, hex flg m6x1.0
9	25 237 14-S	2	Clamp, hose
10	25 050 21-S	1	Filter, fuel
11	25 111 34-S	1	Line, fuel (24" length - Cut to needed ")

NOT ILLUSTRATED

X-22-11-S	1	Washer, internal tooth lock 1/4" (ground)
12 757 02-S	1	Kit, float
12 757 03-S	1	Kit, carburetor repair
12 757 33-S	1	Kit, solenoid repair
12 757 37-S	1	Kit, bowl replacement w/gaskets
20 755 06-S	1	Kit, high altitude (5,000 ft.)
20 755 07-S	1	Kit, high altitude (10,000 ft.)
12 454 03-S	1	Tie, wire

NOTE: All component dimensions given in U.S. inches
1 inch = 25.4 mm

LIMITED WARRANTY ON CRAFTSMAN TRACTOR AND BATTERY

2-YEAR ON TRACTOR

When used and maintained according to the operator's manual instructions, if this tractor fails due to a defect in material or workmanship within two years from the date of purchase, call 1-800-4-MY-HOME® to arrange for free repair.

During the first 30 days of purchase, there will be no charge to service the product in your home. For your convenience, in-home warranty service will still be available after the first 30 days of purchase, but a trip charge will apply. This charge will be waived if you transport the product to an authorized Craftsman drop-off location. For the nearest authorized location, call 1-800-4-MY-HOME®.

Tractor warranty coverage does not include:

- Expendable items which become worn during normal use, including but not limited to blades, spark plugs, air cleaners, belts, and oil filters.
- Standard maintenance servicing, oil changes, or tune-ups.
- Tire replacement or repair caused by punctures from outside objects, such as nails, thorns, stumps, or glass.
- Repairs necessary because of operator abuse, including but not limited to damage caused by towing objects beyond the capability of the tractor, impacting objects that bend the frame or crankshaft, or over-speeding the engine.
- Repairs necessary because of operator negligence, including but not limited to electrical and mechanical damage caused by improper storage, failure to use the proper grade and amount of engine oil, failure to keep the deck clear of flammable debris, or failure to maintain the equipment according to the instructions contained in the operator's manual.
- Engine (fuel system) cleaning or repairs necessary because of fuel determined to be contaminated or oxidized (stale). In general, fuel should be used within 30 days of its purchase date.
- Normal deterioration and wear of the exterior finishes, or product label replacement.
- The tractor battery, which is covered for only 90 days as stated below.

90-DAYS ON BATTERY

For ninety (90) days from the date of purchase, if the battery included with this tractor is defective in material or workmanship (our testing proves it will not hold a charge), it will be replaced free of charge.

During the first 30 days of purchase, there will be no charges to replace the battery in your home. For your convenience, in-home warranty service will still be available after the first 30 days of purchase, but a trip charge will apply. This charge will be waived if you transport the battery to an authorized Craftsman drop-off location. For the nearest authorized location, call 1-800-4-MY-HOME®.

All tractor and battery warranty coverage is void if this product is used for commercial or rental purposes.

This warranty applies only while this product is within the United States.

This warranty gives you specific legal rights, and you may also have other rights, which vary, from state to state.

Sears, Roebuck and Co., Dept. 817WA, Hoffman Estates, IL 60179

