

REPAIR PARTS MANUAL

MODEL NO. 277031

Lawn Tractor

17/42 "



HOW TO USE THIS MANUAL

This manual is designed to provide the customer with a means to identify the parts on his/her tractor when ordering repair parts. The illustrations may or may not represent the actual assemblies; therefore, it is not recommended to use this manual as a guide to assemble or disassemble the tractor. Some hardware and parts are drawn larger in order to more readily identify them.

Each tractor has its own model number.

The model number for your tractor can be found on the fender under the seat.

When ordering parts, always give the following information: ,

- Product - "Tractor"
- Model Number - "277031"
- Part Number
- Part Description

TABLE OF CONTENTS

SCHEMATIC.....	3
ELECTRICAL.....	4-5
CHASSIS.....	6-7
DRIVE.....	8-9
STEERING.....	10-11
SEAT.....	12
DECALS.....	13
ENGINE.....	14-15
MOWER LIFT.....	16-17
MOWER DECK.....	18-19
TRANSAXLE.....	20-21
ENGINE BREAKDOWN.....	22-27
WARRANTY.....	28

TRACTOR- -MODEL NO. 917. 277031

SCHEMATIC

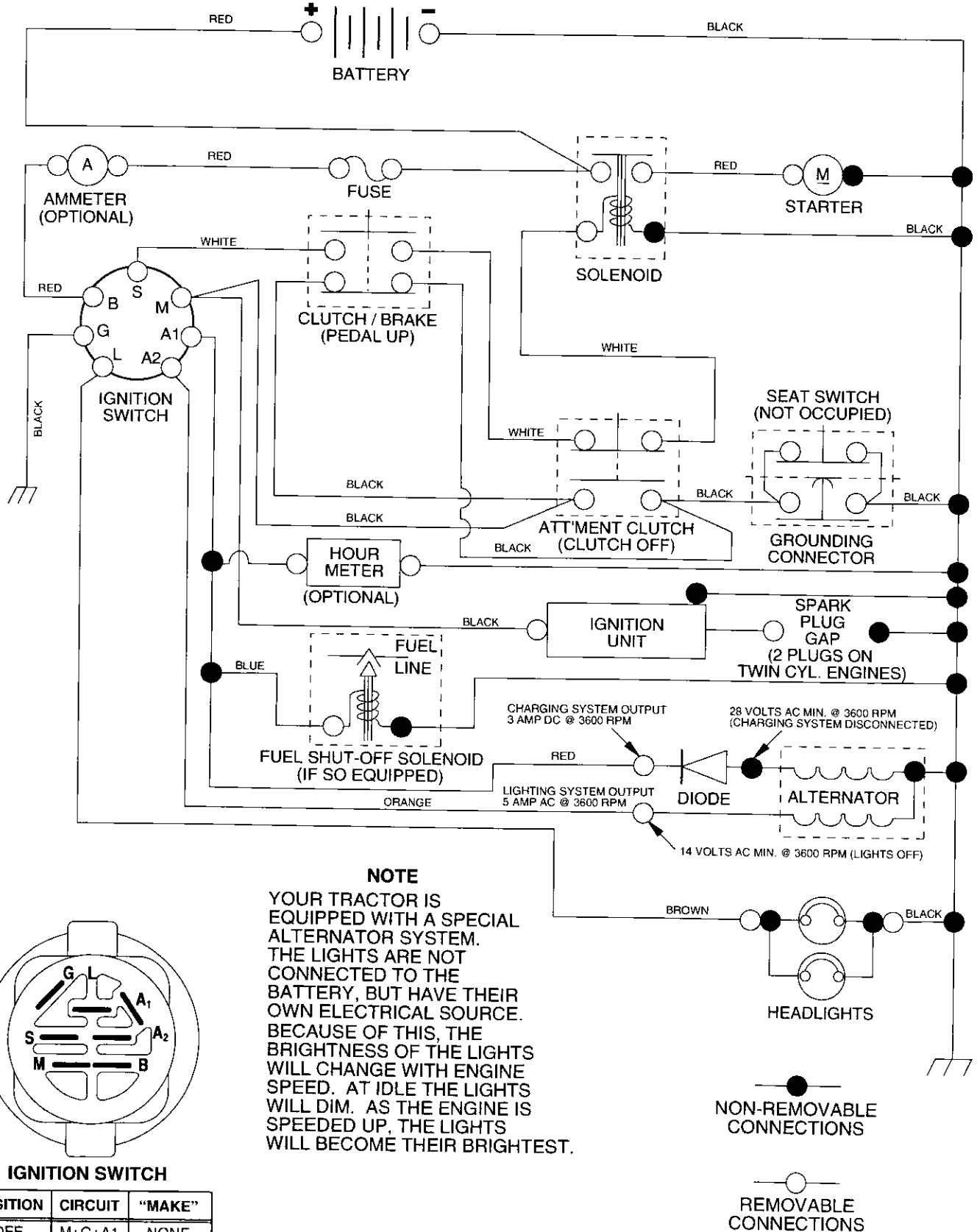

REPAIR PARTS

TRACTOR- -MODEL NO. 917. 277031

ELECTRICAL

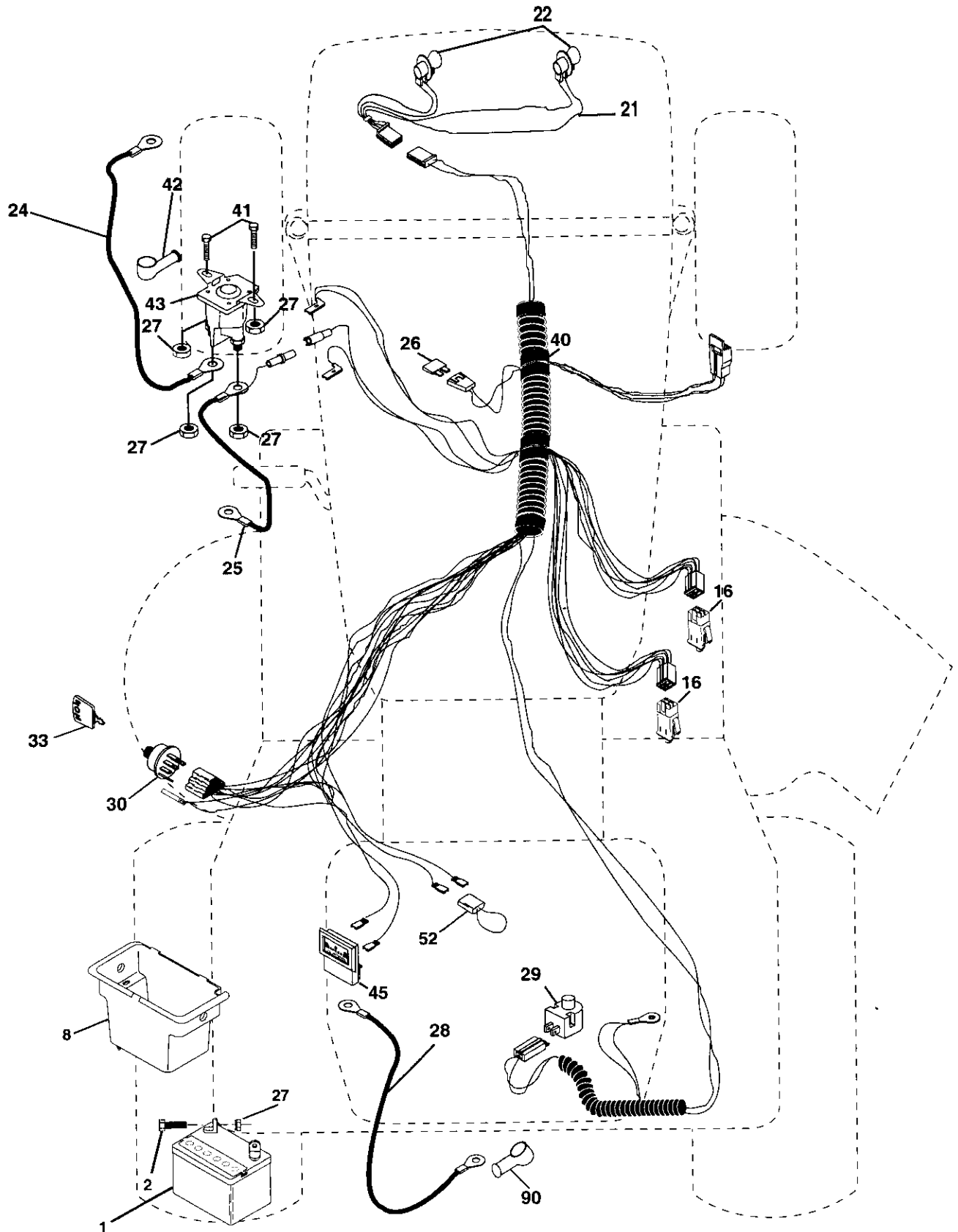

REPAIR PARTS

TRACTOR- -MODEL NO. 917. 277031

ELECTRICAL

KEY NO.	PART NO.	DESCRIPTION
1	163465	Battery
2	74760412	Bolt Hex Hd 1/4-20unc x 3/4
8	176689	Box Battery Fender
16	176138	Switch, Interlock
21	175688	Harness Asm Light W/4152j
22	4152J	Bulb Light #1156
24	4799J	Cable Battery 6 Ga 11" red
25	146147	Cable Battery 6 Ga w/16 wire red
26	175158	Fuse 20 AMP
27	73510400	Nut, Keps Hex 1/4-20 UNC
28	4207J	Cable Ground 6 Ga 12" black
29	121305X	Switch Plunger Nc Gray
30	175566	Switch Ign
33	140403	Key Ign Molded Craftsman
40	179720	Harness Ign
41	71110408	Bolt Blk. Fin Hex 1/4-20 Unc x 1/2
42	131563	Cover Terminal Red
43	178861	Solenoid
45	121433X	Ammeter Rectangular 6 Amp
52	141940	Protection Wire Loop
90	180499	Cover Battery Terminal

NOTE: All component dimensions given in U.S. inches.
1 inch = 25.4 mm.

REPAIR PARTS

TRACTOR- -MODEL NO. 917. 277031

CHASSIS AND ENCLOSURES

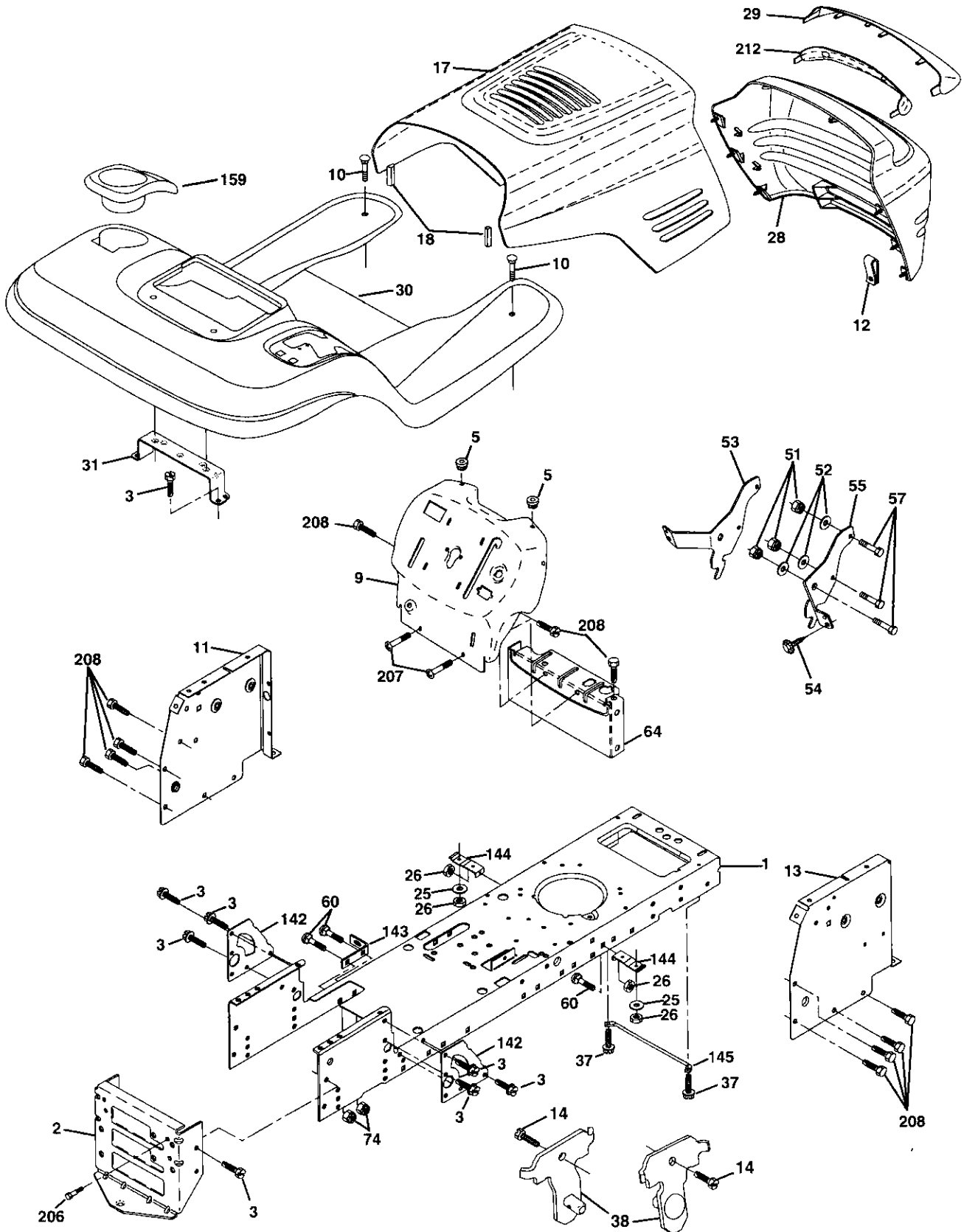

REPAIR PARTS

TRACTOR- -MODEL NO. 917. 277031

CHASSIS AND ENCLOSURES

KEY NO.	PART NO.	DESCRIPTION	KEY NO.	PART NO.	DESCRIPTION
1	174619	Chassis	52	19091416	Washer 9/32 x 7/8 x 16 Ga.
2	176554	Drawbar	53	145201	Bracket Grille Pickoff LH
3	17060612	Screw 3/8-16 x 3/4	54	161464	Screw Hex WSHD 8-18 x 7/8
5	155272	BumperHood/Dash	55	145202	Bracket Grille Pickoff RH
9	168337X012	Dash.	57	STD522507	Bolt, Fin Hex 1/4-20 UNC x .75
10	STD533710	Bolt, Carriage 3/8-16 x 1	60	STD533707	Bolt Rdhd Sqnk 3/8-16 UNC x 3/4
11	174996	Panel, Dash, L.H.	64	154798	Dash Lower STLT
12	145660	Clip Tinnerman Grille P/L	74	STD541437	Nut, Crownlock 3/8-16 UNC
13	172105X010	Panel, Asm. SLKSCR Dash R.H.	142	175702	Plate Reinforcement STLT
14	17490608	Screw Thdrol 3/8-16 x 1/2	143	154966	Bracket Swaybar Chassis
17	144983X558	Hood Assembly	144	175582	Bracket Footrest
18	126938X	BumperHood	145	156524	Rod Pivot Chassis/Hood
25	19131312	Washer 13/32 x 13/16 x 12 Gauge	159	155123X428	Cupholder
26	STD541437	Nut, Lock Hex W/Ins. 3/8-16 UNC	206	170165	Bolt Shoulder 5/16-18 TT
28	178987X558	Grille w/Lens Asm.	207	17670508	Screw Thdrol 5/8-18 x 1/2
29	155217X599	Lens, Grille	208	17670608	Screw Thdrol 3/8-16 x 1/2
30	175692X558	Fender	212	165919	Insert Lens Reflective
31	139976	Bracket, Fender Support	--	5479J	Plug, Button
37	17490508	Screw Thdrol 5/16-18 x 1/2 TYT			
38	175710	Bracket Asm Pivot			
51	73800400	Nut Lock w/Insert 1/4-20 UNC			

NOTE: All component dimensions given in U. S. inches
1 inch = 25.4 mm

REPAIR PARTS

TRACTOR- -MODEL NO. 917. 277031

DRIVE

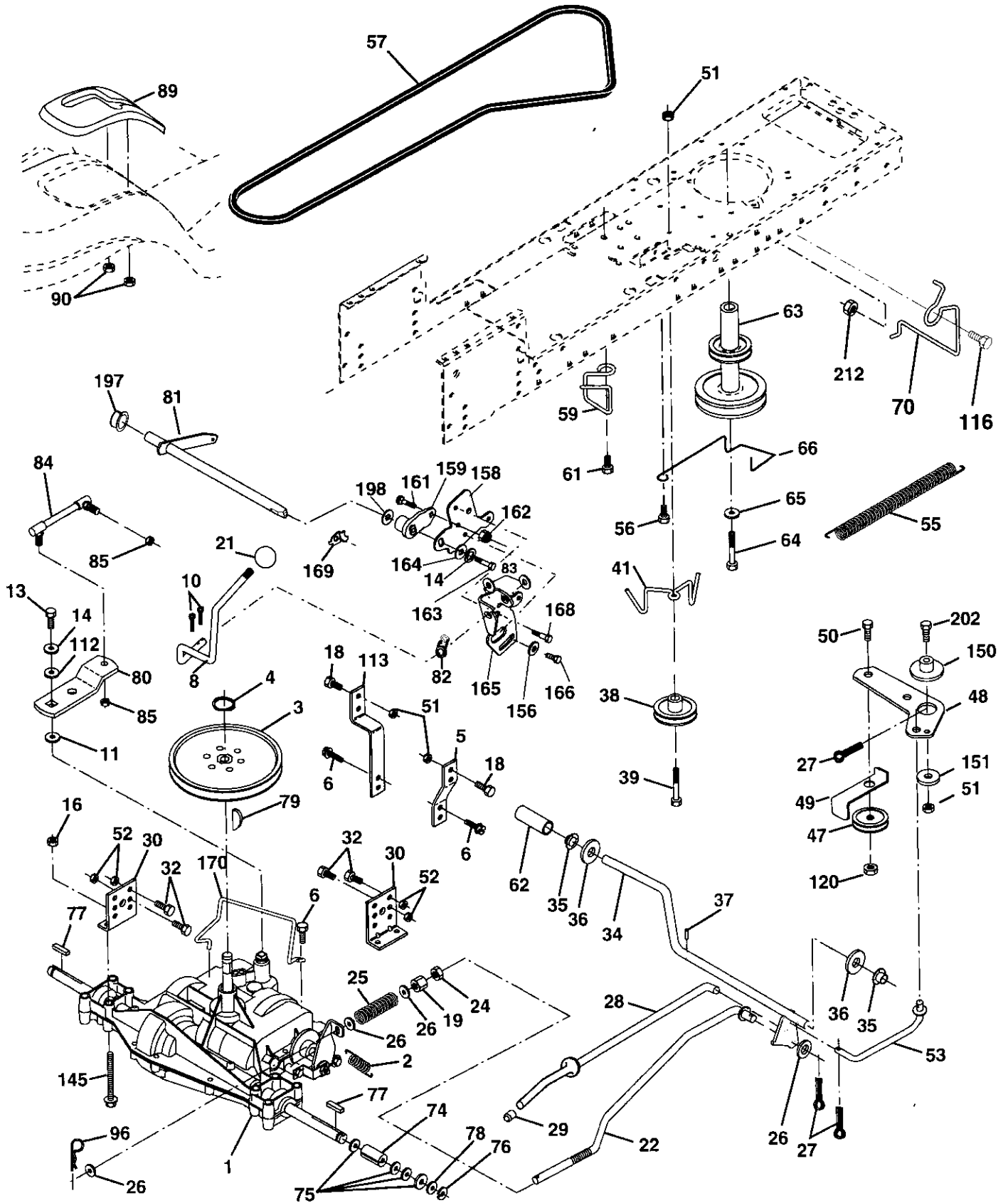

REPAIR PARTS

TRACTOR- -MODEL NO. 917. 277031

DRIVE

KEY NO.	PART NO.	DESCRIPTION	KEY NO.	PART NO.	DESCRIPTION
1	----	Transaxle (See Breakdown)	64	71170764	Bolt Hex 7/16-20 x 4 Gr 5
2	146682	Peerless 206-545C	65	STD551143	Washer Lock Hvy Hlcl Spr 7/16
3	123666X	Spring Return Brake T/a Zinc	66	154778	Keeper Belt Engine
4	12000028	Pulley Transaxle 18/20" tires	70	180218	Guide Belt Mower Drive RH
5	121520X	Ring Retainer # 5100-62	74	137057	Spacer Split
6	17060512	Strap Torque 30 Degrees	75	121749X	Washer 25/32 x 1 1/4 x 16 Ga
8	165866	Screw 5/16-18 x 3/4	76	STD581075	E-ring #5133-75
10	STD561210	Rod Shifter Fender STLT	77	123583X	Key Square
11	105701X	Pin Cotter 1/8 x 1 Cad	78	121748X	Washer 25/32 x 1-5/8 x 16ga
13	74550412	Washer Plate Shf 388 Sq Hole	79	2228M	Key Woodruff
14	10040400	Bolt 1/4-28unf Gr8 W/Patch	80	131486	Arm, Shift
16	STD541431	Washer Lock Hvy Helical 1/4	81	165594	Shaft Assembly
18	STD523710	Nut Lock Hex w/Ins. 5/16-18 Unc	82	165711	Spring, Torsion
19	STD541437	Bolt Fin Hex 3/8-16unc x 1 Gr.5	83	19171216	Washer 17/32 x 3/4 x 16 Gauge
21	106933X	Nut Lock Hex W/Ins. 3/8-16 Unc	84	166228	Link Transaxle
22	130804	Knob Rd 1/2-13 Plstc Thds Blk	85	150360	Nut, Nylock
24	STD541237	Rod Brake Blk Zinc 26 840	89	158391X428	Console, Shift, STLT
25	106888X	Nut Hex Jam 3/8-16 Unc	90	124346X	Nut, Self-Threading, Washer Hd 1/4
26	STD551037	Spring Rod Brake 2 00 Zinc	96	STD624003	Retainer Spring
27	STD561210	Washer 13/32 x 13/16 x 16 Ga	112	19091210	Washer 9/32 x 3/4 x 10 Ga
28	175765	Pin Cotter 1/8 x 3/4 Cad	113	127285X	Strap Torque
29	71673	Rod Brake Parking Lt/Yt	116	STD533710	Bolt RdHd Sqnk 3/8-16 x 1 Unc
30	174973	Cap Brake Parking	120	73900600	Nut Lock Flg. 3/8-16 Unc
32	STD523107	Bracket Mtg Transaxle	145	74490540	Bolt Hex Flghd 5/16-18 x Gr.5
34	175578	Bolt Hex Hd 5/16-18unc x 3/4	150	175456	Spacer Retainer
35	120183X	Shaft Asm Pedal Foot	151	19133210	Washer 13/32 x 2 x 10 Ga.
36	STD551062	Bearing Nylon Blk 629 Id	156	166002	Washer Srrted 5/16ID x 1 .125
37	STD571810	Washer 21/32 x 1 x 16 Ga	158	165589	Bracket Shift Mount
38	179114	Pin Roll 3/16 x 1"	159	165494	Hub Tapered Flange Shift Lt
39	74760648	Pulley Composite Flat	161	72140406	Bolt Rdhd Sqnk 1/4-20 x 3/4 Gr.5
41	175556	Bolt Fin Hex 3/8-16unc x 3	162	73680400	Nut Crownlock 1/4-20 UNC
47	127783	Keeper Belt Idler	163	74780416	Bolt Hex Fin 1/4-20 UNC x 1 Gr.5
48	154407	Pulley Idler	164	19091010	Washer 5/8 x .281 x 10 Ga.
49	123205X	Bellcrank Clutch Grnd Drv STL	165	165623	Bracket Pivot Lever
50	STD523715	Retainer Belt Style Spring	166	166880	Screw 5/16-18 x 5/8
51	STD541437	Bolt Hex Hd 3/8-16unc x 1-1/2	168	165492	Bolt shoulder 5/16-18 x .561
52	STD541431	Nut Crownlock 3/8-16 UNC	169	165580	Plate Fastening Lt
53	105710X	Nut Crown Lock 5/16-18	170	178394	Keeper Belt T/A
55	105709X	Link Clutch 7 66	197	169613	Nyliner Snap-In 5/8" ID
56	17060620	Spring Return Clutch 6 75	198	169593	Washer Nyl 7/8ID x .105"
57	138301	Screw 3/8-16 x 1-1/4	202	72110614	Bolt Carr Sh 3/8-16 x 1-3/4 Gr.5
59	169691	V-Belt Gd Drive	212	145212	Nut Hex Flange Lock
61	17120614	Keeper Belt Centerspan			
62	8883R	Screw 3/8-16 x .875			
63	180219	Cover Pedal Blk Round			
		Pulley Eng			

NOTE: All component dimensions given in U.S. inches
1 inch = 25.4 mm

REPAIR PARTS

TRACTOR- -MODEL NO. 917. 277031

STEERING ASSEMBLY

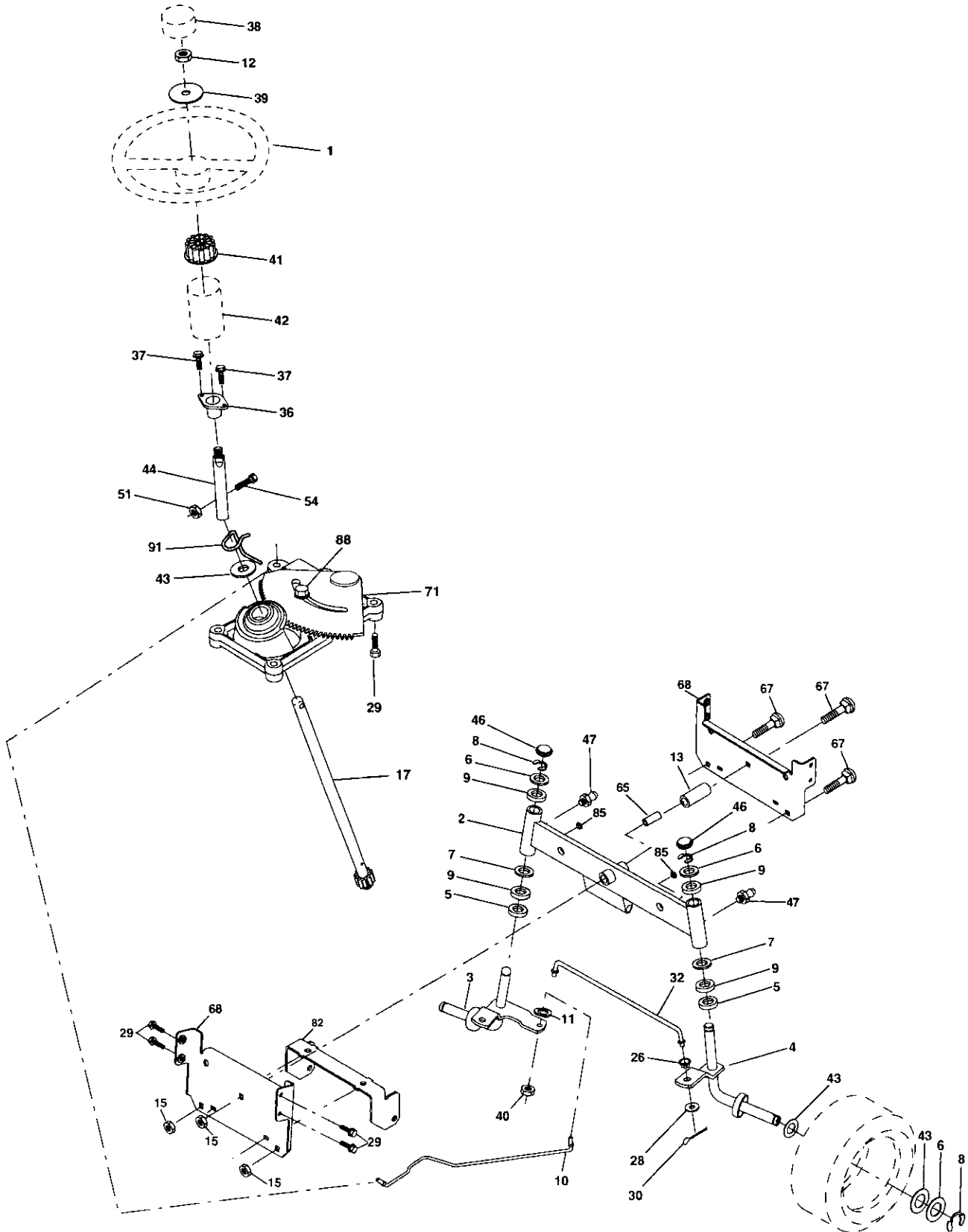

REPAIR PARTS

TRACTOR- -MODEL NO. 917. 277031

STEERING ASSEMBLY

KEY NO.	PART NO.	DESCRIPTION
1	139768	Steering Wheel
2	175131	Front Axle Assembly
3	169840	Spindle Assembly, L.H.
4	169839	Spindle Assembly, R.H.
5	6266H	Bearing, Race, Thrust, Hardened
6	121748X	Washer 25/32 x 1-5/8 x 16 Gauge
7	19272016	Washer 27/32 x 1-1/4 x 16 Gauge
8	12000029	Ring, Klip
9	3366R	Bearing, Steering Column
10	175121	Link, Drag
11	STD551137	Washer, Lock
12	73940800	Nut Hex Jam Toplock 1/2-20 UNF
13	136518	Spacer, Bearing, Front Axle
15	145212	Nut Lock Hex Flange
17	180641	Shaft Asm. Steering
26	126847X	Bushing, Link, Drag
28	19131416	Washer 13/32 x 7/8 x 16 Gauge
29	17060612	Screw 3/8-16 x 3/4
30	STD561210	Pin
32	130465	Rod, Tie
36	155099	Bushing, Steering
37	152927	Screw TT #10-32 x 5 x 3/8 Flange
38	139769	Cap Wheel Steer OPP Blk
39	19183812	Washer 9/16 ID x 2-3/8 OD 12 Gr
40	STD541537	Nut Lock Center 3/8-24 UNF
41	100711L	Adaptor, Steering Wheel
42	145054X428	Boot, Steering Dash P/L Mtl Blk
43	121749X	Washer 25/32 x 1-1/4 x 16 Gauge
44	180640	Extension Steering Non-Adjust
46	121232X	Cap, Spindle
47	6855M	Fitting, Grease
51	73540400	Nut Crownlock 1/4-28
54	71130420	Bolt Hex 1/4-28 UNF x 1-1/4 Gr 8
65	160367	Spacer Brace Axle
67	72140618	Bolt Rdhd Sq 3/8-16 x 2-1/4
68	169827	Brace Axle
71	175146	Steering Asm.
82	169835	Bracket Susp Chassis Front
85	133835	Fastener Christmas Tree
88	175118	Bolt Shoulder 7/16-20 Unc
91	175553	Clip Steering

NOTE: All component dimensions given in U. S. inches 1 inch = 25.4 mm

REPAIR PARTS

TRACTOR- -MODEL NO. 917. 277031

SEAT ASSEMBLY

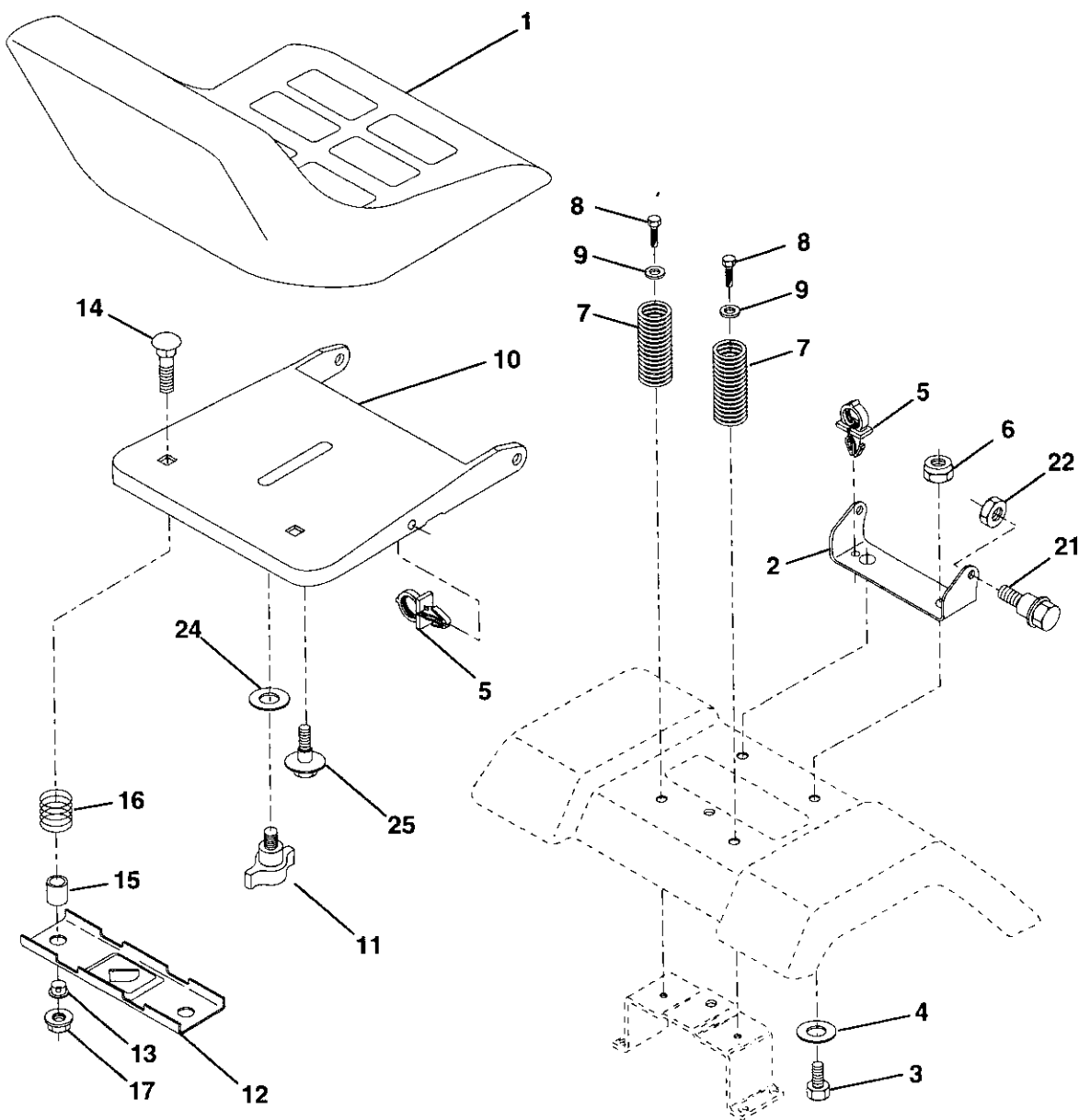

KEY NO.	PART NO.	DESCRIPTION
1	140122	Seat
2	140551	Bracket Pnt Pivot Seat (blk)
3	71110616	Bolt Fin Hex 3/8-16unc X 1
4	19131610	Washer 13/32 X 3/4 X 10 Ga
5	145006	Clip Push In Hinged
6	STD541437	Nut Hex Lock w/Ins 3/8-16 Unc
7	124181X	Spring Seat Cprsn 2 250 Blk Zi
8	17000616	Screw 3/8-16 X 1 -1/2
9	19131614	Washer 13/32 X 1 X 14 Ga
10	182493	Pan Pnt Seat (blk)
11	166369	Knob Seat
12	121246X	Bracket Pnt Mounting Switch

KEY NO.	PART NO.	DESCRIPTION
13	121248X	Bushing Snap Blk Nyl 50 Id
14	72050412	Bolt Rdhd Sht Nk 1/4-20x1-1/2
15	134300	Spacer Split 28 X 96 Zinc
16	121250X	Spring Cprsn 1 27 Blk Pnt
17	123976X	Nut Lock 1/4 Lge Flg Gr 5 Zinc
21	171852	Bolt Shoulder 5/16-18 Unc-2A
22	STD541431	Nut Hex Lock w/Ins 5/16-18
24	19171912	Washer 17/32 X 1-3/16 X 12 Ga
25	127018X	Bolt Shoulder 5/16-18 X 62

NOTE: All component dimensions given in U.S. inches.
1 inch = 25.4 mm

REPAIR PARTS

TRACTOR- -MODEL NO. 917. 277031

DECALS

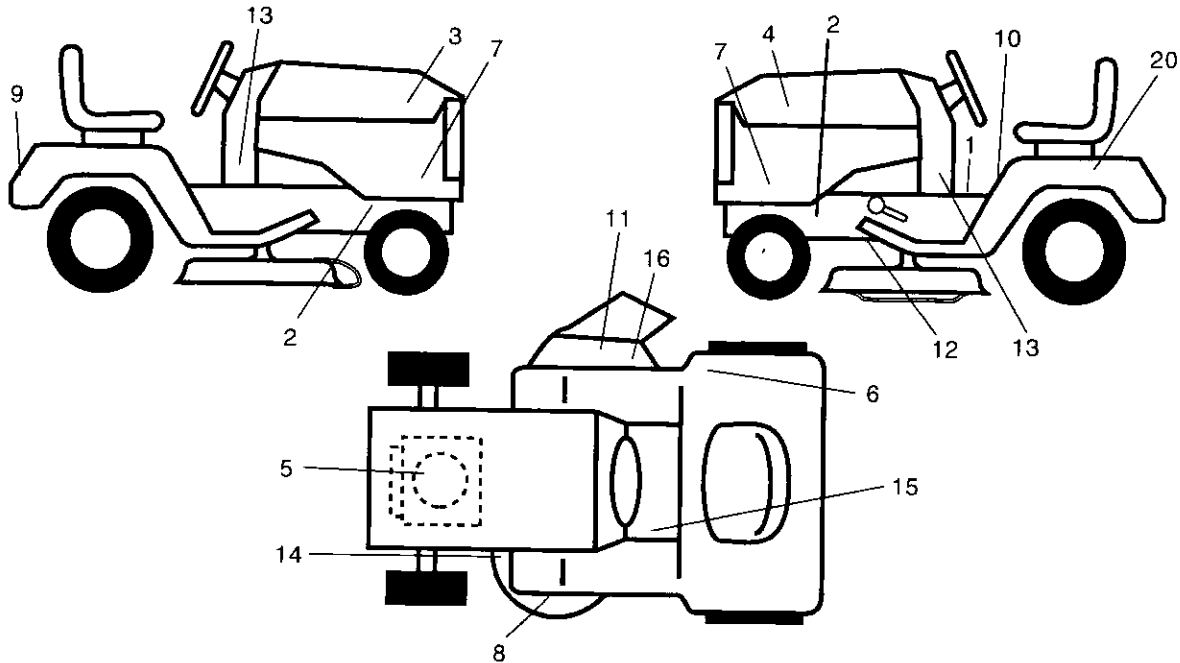

KEY NO.	PART NO.	DESCRIPTION
1	145498	Decal, Oper. Instr.
2	159736	Decal, Chassis Hot Muffler
3	171696	Decal, Hood Rh
4	171697	Decal, Hood Lh
5	181450	Decal, Hp Engine
6	180432	Decal, Fender 100 DB/CE
7	177253	Decal, Hood Side
8	172331	Decal Mower
9	163204	Decal, Fender Craftsman
10	140837	Decal, Brake Parking Saddle
11	179128	Decal, Deck

KEY NO.	PART NO.	DESCRIPTION
12	146046	Decal, V-belt Dr Sch
13	181702	Decal, Dash, Panel
14	160396	Decal, V-belt Schematic
15	159737	Decal Brake/Clutch
16	182166	Decal CE 02 Cutfinger
20	145005	Decal, Battery Dngr/Psn Eng
--	138311	Decal, Lift Handle
--	165800X428	Pad, Footrest LH STL
--	165799X428	Pad, Footrest RH STL
--	162598	Decal, Draw Bar Load
--	183342	Manual, Owner's (Euro)
--	183343	Manual, Owner's (Scan)
--	183344	Manual, Parts

WHEELS & TIRES

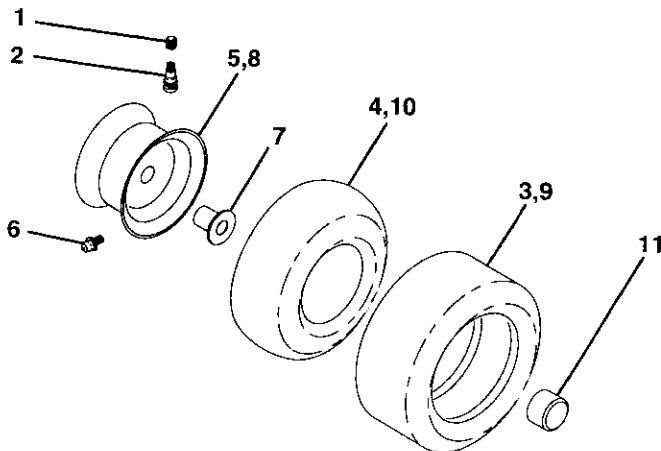

KEY NO.	PART NO.	DESCRIPTION
1	59192	Cap Value Tire
2	65139	Stem Value
3	106222X	Tire F Ts 15 X 6 0 - 6 Service
4	59904	Tube Inner Front #35060
5	106732X624	Rim Asm 6"front White Service
6	278H	Fitting Grease
7	9040H	Bearing Flange
8	106108X624	Rim Asm 8"rear White Service
9	106268X	Tire R Ts 18x9 5-8 Service
10	7152J	Tube Rear 9 5 X 8 Service
11	104757X428	Cap Axle Blk 1 50 X 1 00
--	144334	Sealant, Tire (10 oz. tube)

NOTE: All component dimensions given in U.S. inches
1 inch = 25.4 mm

REPAIR PARTS

TRACTOR- -MODEL NO. 917. 277031

ENGINE

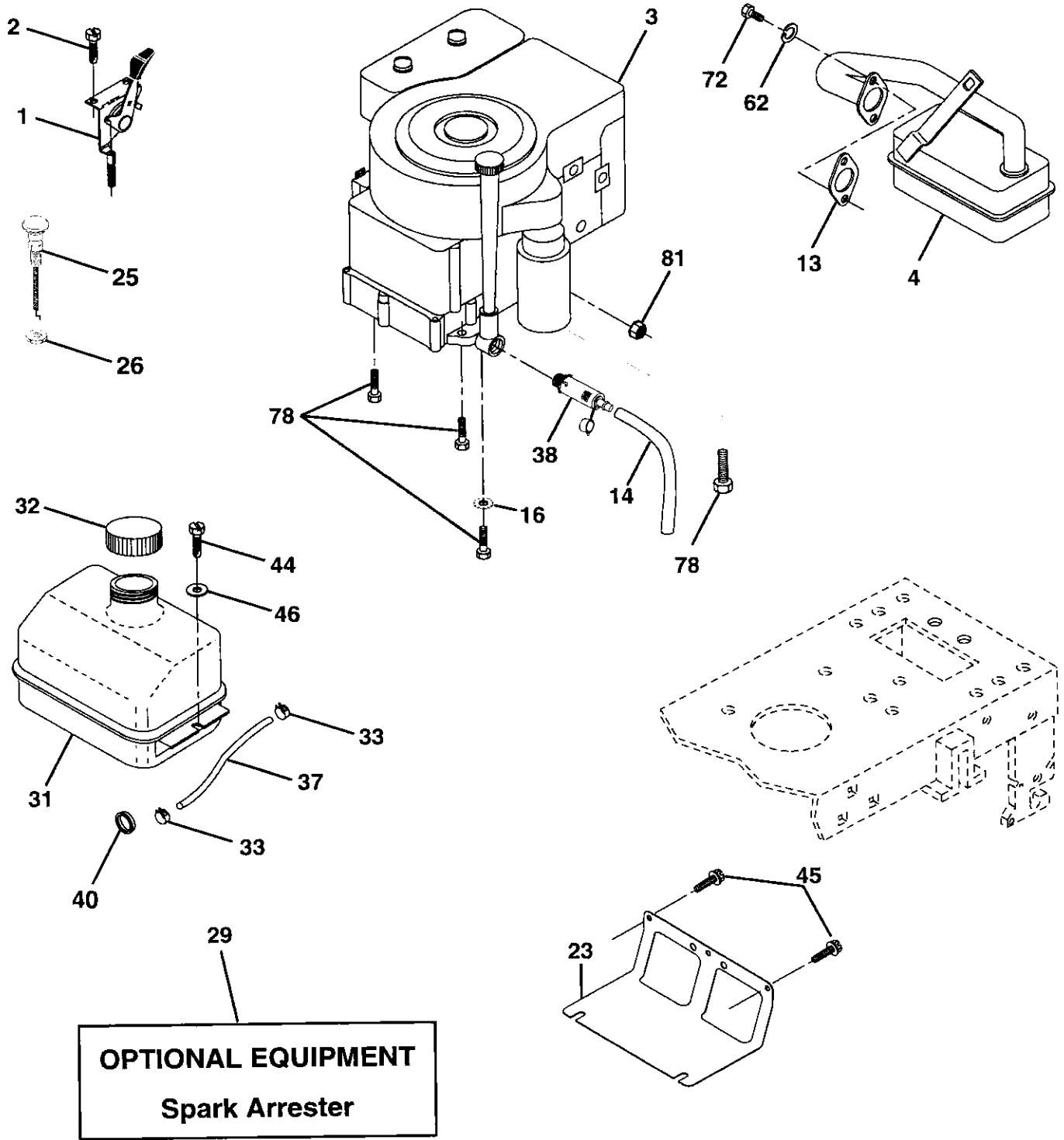

REPAIR PARTS

TRACTOR- -MODEL NO. 917. 277031

ENGINE

KEY NO.	PART NO.	DESCRIPTION
1	170545	Control Throttle/Choke
2	17720408	Screw Hex Thd Cut 1/4-20x1/2 T
3	-----	Engine (See Breakdown) Briggs Model 310707-0203-E1
4	137352	Muffler Exhaust B&S Lt
13	165291	Gasket 1 313 Id Tin Plated
14	148456	Tube Drain Oil
16	STD551237	Washer Lock Ext Tooth 3/8
23	169837	Shield BRN/DBR Guard
25	180945	Control Choke
26	73920600	Nut Keps 3/8-24 Unf
29	137180	Arrestor Spark
31	109202X	Tank Fuel 1 25 Fr
32	158990	Cap Asm Fuel W/sym Vented
33	123487X	Clamp Hose Blk
37	137040	Line Fuel 20"
38	148315	Plug Oil Drain
40	124028X	Bushing Snap Nyl Blk Fuel Line
44	17670412	Screw Hexwsh Thdrol 1/4-20x3/4
45	17000612	Screw Hexwsh Thdr 3/8-16 x 3/4
46	19091416	Washer 9/32 X 7/8 X 16ga
62	STD551131	Washer Lock Hvy Hlcl Spr 5/16
72	71070512	Screw Hexhd Cap 5/16-18x3/4
78	17060620	Screw 3/8-16x1-1/4
81	73510400	Nut Keps Hex 1/4-20unc

NOTE: All component dimensions given in U.S.
inches 1 inch = 25.4 mm

REPAIR PARTS

TRACTOR- -MODEL NO. 917. 277031

MOWER LIFT

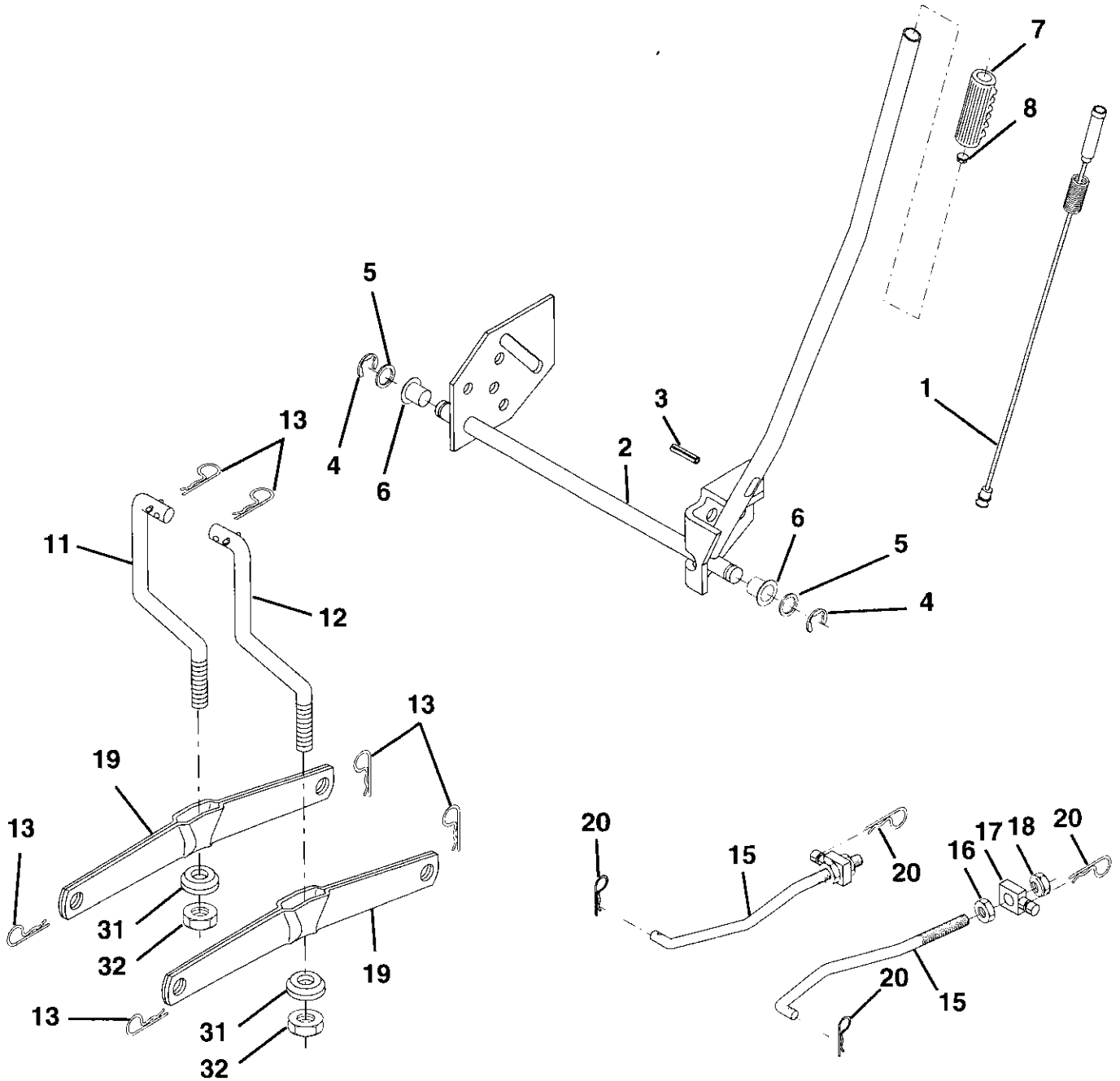

REPAIR PARTS

TRACTOR- -MODEL NO. 917. 277031

MOWER LIFT

KEY NO.	PART NO.	DESCRIPTION
1	159460	Washer Asm Inner Spring W/ Plunger
2	159471	Shaft Asm. Lift RH
3	105767X	Pin Groove
4	12000002	E Ring #5133-62
5	19211621	Washer 21/32 x 1 x 21 Ga.
6	120183X	Bearing Nylon
7	125631X	Grip Handle Fluted
8	122365X	Button Plunger Read
11	139865	Link Asm Lift L.H.
12	139866	Link Asm Lift R.H.
13	STD624008	Retainer Spring
15	173288	Link Front
16	73350800	Nut Jam Hex 1/2-13 Unc
17	175689	Trunnion Front Susp.
18	73800800	Nut Lockw/wsh 1/2-13 Unc
19	139868	Arm Suspension Mower
20	163552	Retainer Spring
31	169865	Bearing, Pvt. Lift.
32	73540600	Nut Crownlock 3/8-24

NOTE: All component dimensions given in U.S. inches
1 inch = 25.4 mm

REPAIR PARTS

TRACTOR- -MODEL NO. 917. 277031

MOWER

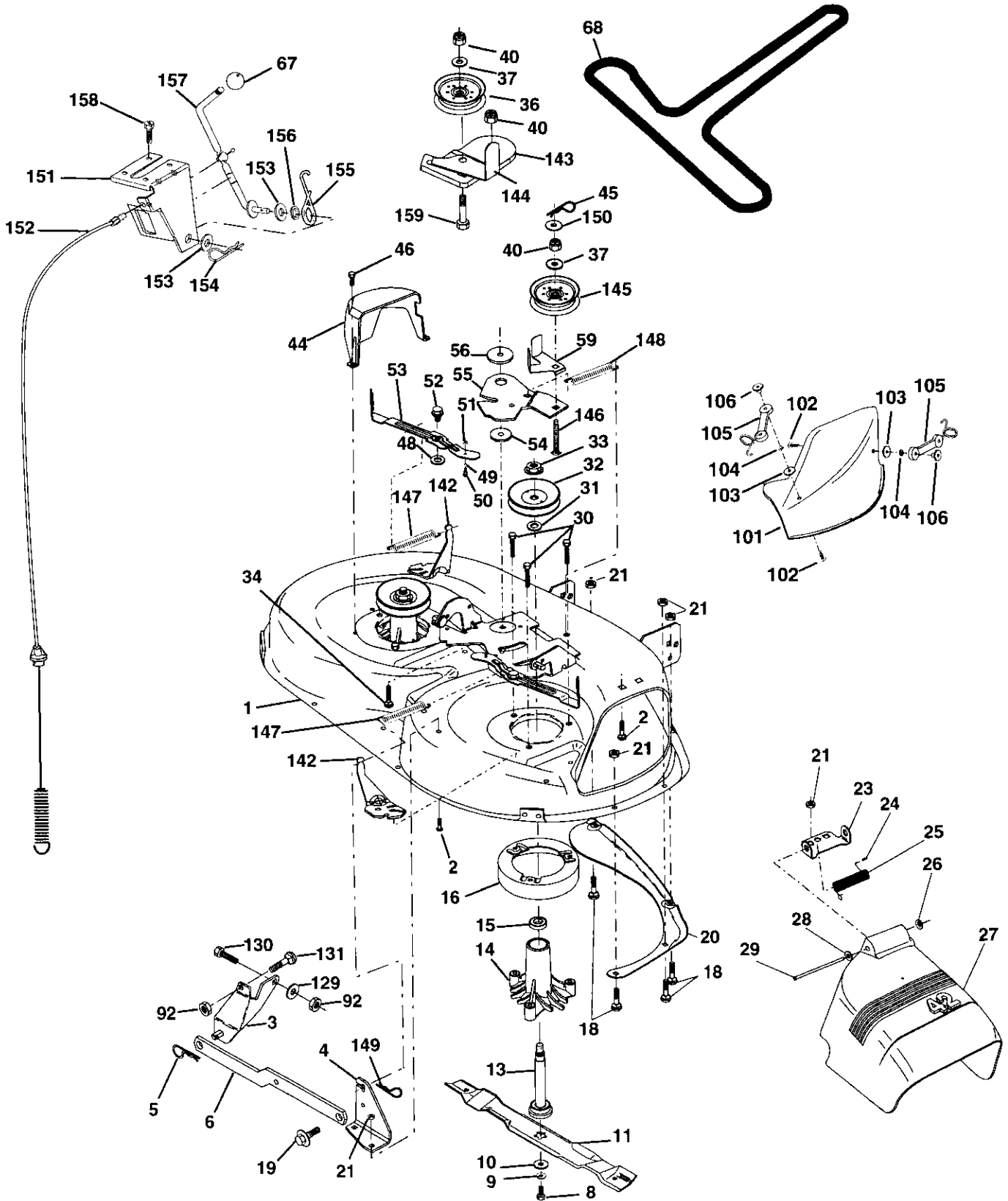

REPAIR PARTS

TRACTOR- -MODEL NO. 917. 277031

MOWER

KEY NO.	PART NO.	DESCRIPTION	KEY NO.	PART NO.	DESCRIPTION
1	165892	Mower Deck Assembly, 42"	54	133943	Washer, Hardened
2	STD533107	Bolt	55	155046	Arm, Idler
3	138017	Bracket Assembly, Sway Bar, Front	56	165723	Spacer, Retainer
4	165460	Bracket Sway Bar 38/42" Deck	59	141043	Guard, TUV Idler
5	STD624008	Retainer Spring	67	149846	Knob Custom Oval
6	178024	Bar Sway Deck	68	180215	V-Belt
8	850857	Bolt, Hex 3/8-24 x 1.25 Gr. 8	92	STD541437	Nut
9	STD551137	Washer, Lock	101	136420	Mulcher Cover
10	140296	Washer, Hardened	102	71081010	Screw
11	134149	Blade, Mulching	103	19061216	Washer #10
13	180074	Shaft Assembly, Mandrel, Vented	104	STD551110	Washer, Lock
14	128774	Housing, Mandrel, Vented	105	160793	Latch Assembly, Bagger
15	110485X	Bearing, Ball, Mandrel	106	2029J	Nut, Weld
16	174493	Stripper, Vented Mower Deck	129	19131312	Washer 13/32 x 13/16 x 12 Ga.
18	72140505	Bolt, Carriage 5/16-18 x 5/8	130	STD523710	Bolt, Fin Hex 3/8-16 UNC x 1 Gr.5
19	132827	Bolt, Shoulder	131	STD533710	Bolt, Rdhd Sqnk 3/8-16UNC x 1
20	159770	Baffle, Vortex	142	165890	Arm Spring Brake Mower
21	STD541431	Nut Crownlock 5/16-18UNC	143	157109	Bracket Arm Idler 42"
23	177563	Bracket, Deflector	144	158634	Keeper Belt 42" Clutch Cable
24	105304X	Cap, Sleeve	145	165888	Pulley Idler Flat
25	123713X	Spring, Torsion, Deflector	146	171977	Bolt Carriage Idler
26	110452X	Nut, Push	147	179748	Spring Extension
27	130968X428	Shield, Deflector	148	169022	Spring Return Idler
28	19111016	Washer 11/32 x 5/8 x 16 Ga.	149	165898	Retainer Spring Yellow Zinc
29	131491	Rod, Hinge	150	19091216	Washer 9/32 x 3/4 x 16 Ga.
30	173984	Screw Thd Roll Dod Pt. Hex	151	169670	Bracket Clutch
31	129963	Washer, Spacer	152	181555	Cable Clutch 42 In
32	153535	Pulley, Mandrel	153	169674	Washer Flat 3/8" Type B
33	178342	Nut, Toplock, Flanged	154	169675	Spring Retainer
34	STD533717	Bolt	155	169671	Spring Retention Lever
36	131494	Pulley, Idler, Flat	156	169672	Spacer
37	STD551037	Washer 13/32 x 13/16 x 16 Ga.	157	169669	Rod Clutch
40	STD541437	Nut Crownlock 3/8-16UNC	158	17720408	Screw Hex Thd Cut 1/4-20 x 1/2
44	140088	Guard, Mandrel, L.H.	159	72140614	Bolt Tdhd Sgn 3/8-16UNC x 1-3/4
45	STD624003	Retainer	--	130794	Mandrel Assembly (Includes Housing, Shaft and Shaft Hardware Only - Pulley Not Included)
46	137729	Screw, Thd. Roll 1/4-20 x 5/8	--	181268	Replacement Mower, Complete
48	133944	Washer, Hardened			
49	174284	Roller Assembly, Cam Follower			
50	131340	Bolt, Shoulder #10-24 Grade 5			
51	STD541410	Locknut			
52	139888	Bolt, Shoulder 5/16-18 UNC			
53	131845	Arm Assembly, Pad, Brake			

NOTE: All component dimensions given in U. S. inches 1 inch = 25.4 mm

REPAIR PARTS

TRACTOR- -MODEL NO. 917. 277031

PEERLESS TRANSAXLE - MODEL NUMBER 206-545C

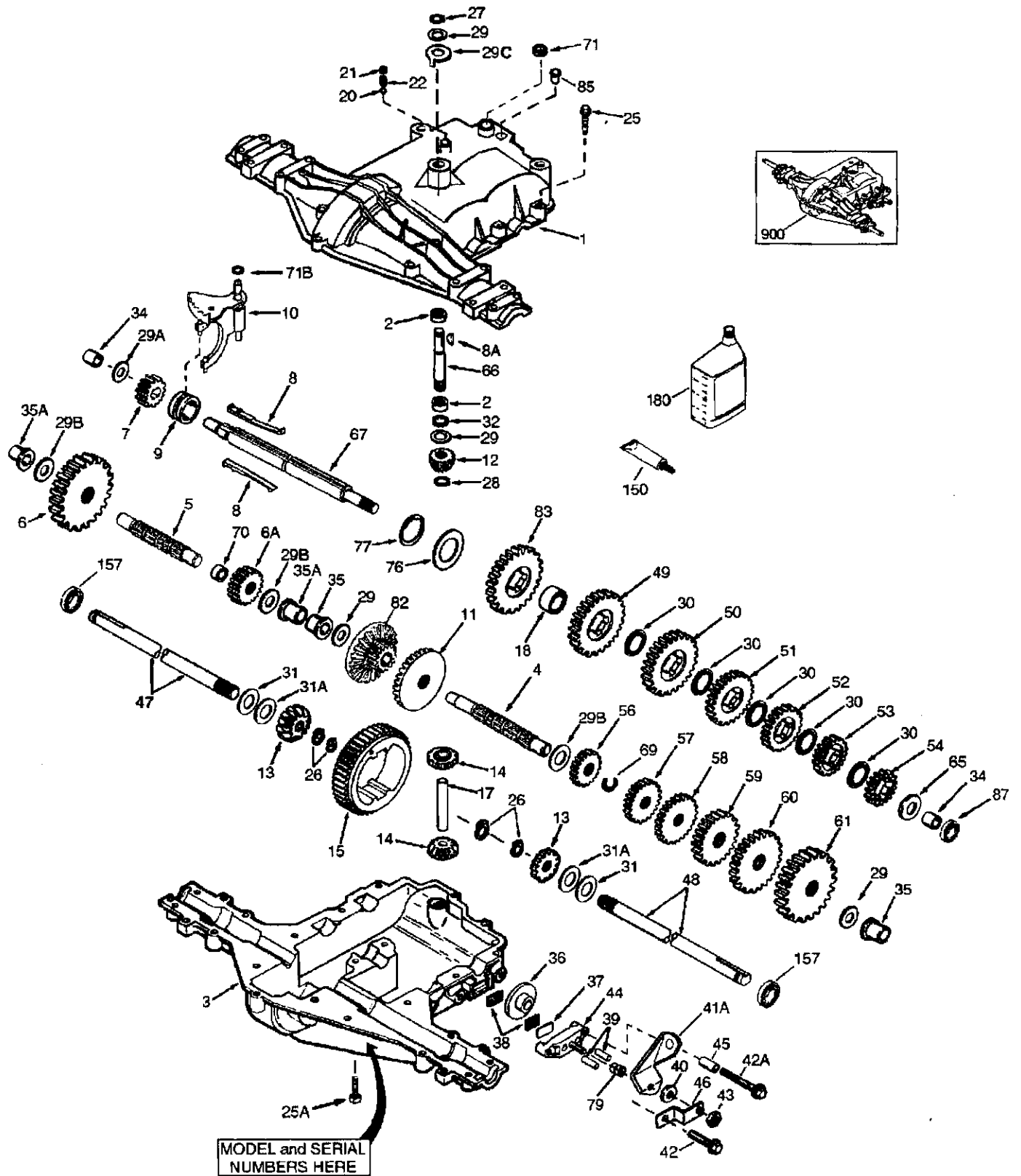

REPAIR PARTS

TRACTOR- -MODEL NO. 917. 277031

PEERLESS TRANSAXLE - MODEL NUMBER 206-545C

KEY NO.	PART NO.	DESCRIPTION	KEY NO.	PART NO.	DESCRIPTION
1	772147	Transaxle Cover	41A	790079	Brake Lever
2	780086A	Needle Bearing 5/8"	42	792073A	Screw 1/4 - 20 x 1-1/4"
3	770128	Transaxle Case	42A	792085A	Screw 1/4 - 20 x 2 1/4"
4	776395	Countershaft	43	792075	Locknut 5 / 16 - 24
5	776409	Output Shaft	44	790025	Brake Pad Holder
6	778364	Spur Gear (38 teeth)	45	786066	Spacer .2625 x 1.0
6A	778369	Spur Gear (15 teeth)	46	786086	Brake Lever Bracket
7	778330	Spur Gear (11 teeth)	47	774690	Axle (11-15 / 16" Long)
8	792180	Shift Key	48	774691	Axle (16 - 1 / 2" long)
8A	792047	Woodruff Key #9	49	778356	Spur Gear (29 teeth)
9	784352	Shift Collar	50	778338	Spur Gear (27 teeth)
10	784378	Shift Rod & Fork	51	778354	Spur Gear (23 teeth)
11	778334	Bevel Gear (30 teeth)	52	778352	Spur Gear (19 teeth)
12	778309	Input Bevel Pinion (13 teeth)	53	778350	Spur Gear (16 teeth)
13	778368	Bevel Gear (13 teeth) (Include. 14)	54	778346	Spur Gear (15 teeth)
14	778368	Bevel Pinion (13 teeth) (Include. 13)	56	778355	Spur Gear (11 teeth)
15	778370	Ring Gear (43 teeth)	57	778337	Spur Gear (13 teeth)
17	786188	Drive Pin	58	778353	Spur Gear (17 teeth)
18	786102	Spacer 1.130 X .695	59	778351	Spur Gear (21 teeth)
20	792077A	Ball 5/16" dia	60	778349	Spur Gear (24 teeth)
21	792078	Set Screw 3/8 - 16 x 3/8"	61	778345	Spur Gear (25 teeth)
22	792079	Spring .310 OD x .625 L	65	780189	Flat Washer .563 ID x .062W
25	792073A	Screw 1/4 - 20 x 1-1/4"	66	776422	Input Shaft
25A	792177	Screw 1/4-20 x 1-3/8"	67	776396	Shifter & Brake Shaft
26	792125	Retaining Ring (pkg of 2)	69	792170	Retaining Ring
27	792035	Retaining Ring	70	786187	Spacer .890
28	788040	Retaining Ring	71	788069	Square Cut Ring
29	780072	Thrust Washer .627 ID x .031W	71B	788092	"O" Ring
29A	780160	Thrust Washer .762 ID x .031W	76	780090	Flat Washer 1.128 ID x .058W
29B	780051	Thrust Washer .762 ID x .031W	77	788078A	Inverted Retaining Ring
29C	780199	Anti-Rotation Washer .632	79	792144	Spring .430 OD x .5000 L
30	780108	Cup Washer 1.127 ID x .032W	82	778333	Bevel & Spur Gear (30 & 13 teeth)
31	780001	Flat Washer .750 ID x .056W (Use As Needed)	83	778338	Spur Gear (27 teeth)
31A	780195	Flat Washer .750 ID x .062W	85	792154	Oil Fill Plug
32	788083	Oil Seal 5/8"	87	788089A	Oil Seal 9 / 16"
34	780194	Bushing .563	150	788093A	Liquid Gasket RTV Silicone
35	780193	Flanged Bushing 5 / 8" ID	157	788088A	Oil Seal 3 / 4"
35A	780197	Flanged Bushing .751	180	730229A	Gear Oil 80W90
36	790075	Brake Disk	900	794712	Replacement MST - 206-545C Transaxle
37	790007	Brake Pad Plate			
38	799021	Brake Pad (pkg of 2)			
39	786026	Dowel Pin			
40	792076A	Flat Washer .312 ID x .059W			

NOTE: All component dimensions given in U.S. inches
1 inch = 25.4 mm

REPAIR PARTS

TRACTOR- -MODEL NO. 917. 277031

BRIGGS & STRATTON ENGINE - - MODEL NUMBER 310707, TYPE NUMBER 0203-E1

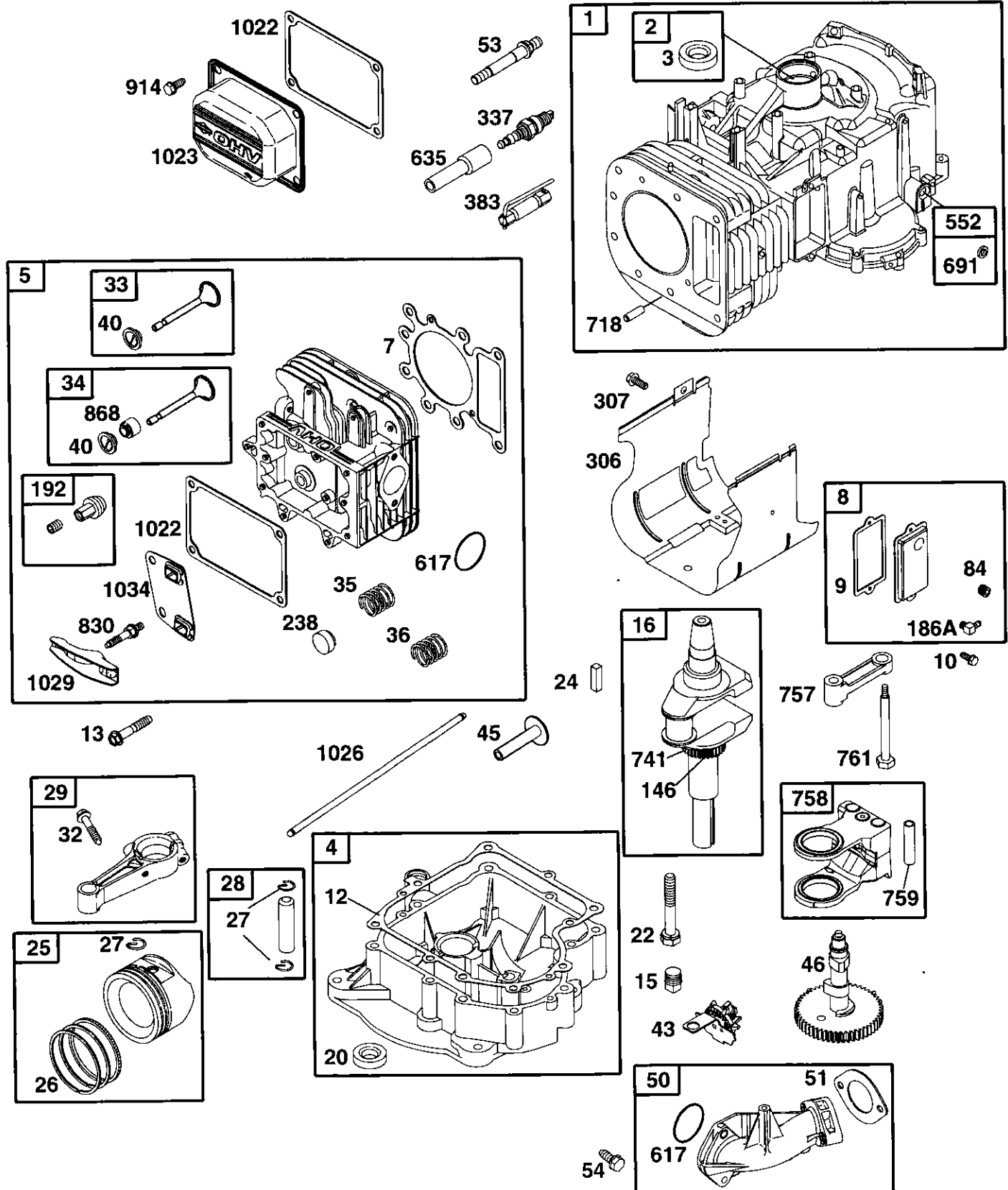

310707-0203-E1

REPAIR PARTS

TRACTOR- -MODEL NO. 917. 277031

BRIGGS & STRATTON ENGINE - - MODEL NUMBER 310707, TYPE NUMBER 0203-E1

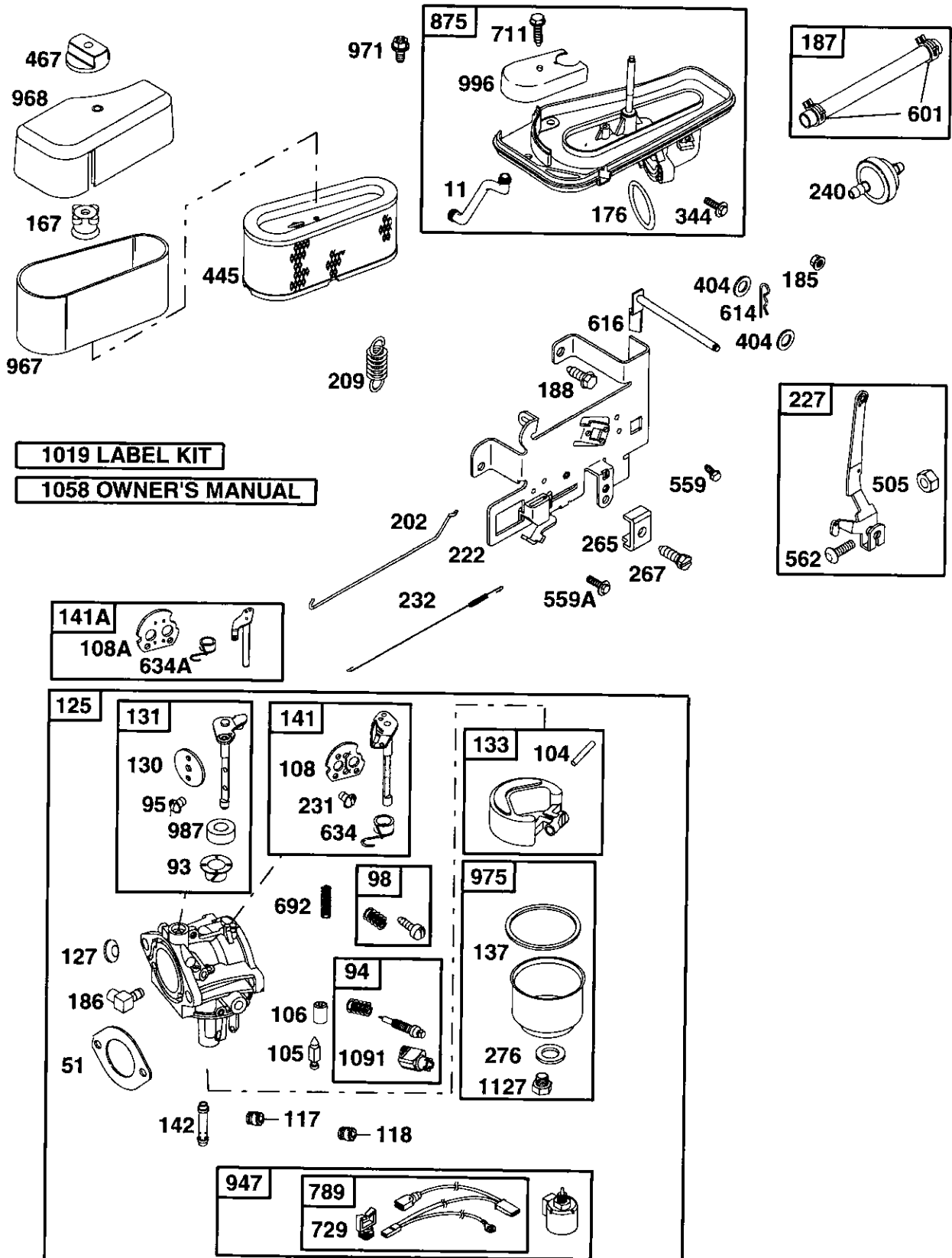

310707-0203-E1

REPAIR PARTS

TRACTOR- -MODEL NO. 917. 277031

BRIGGS & STRATTON ENGINE - - MODEL NUMBER 310707, TYPE NUMBER 0203-E1

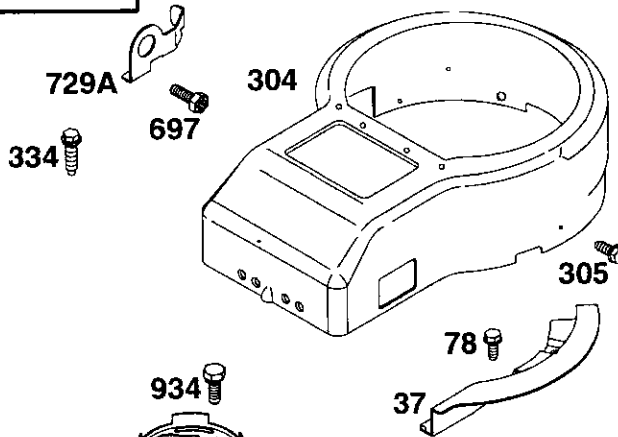
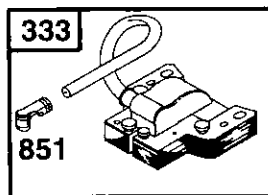
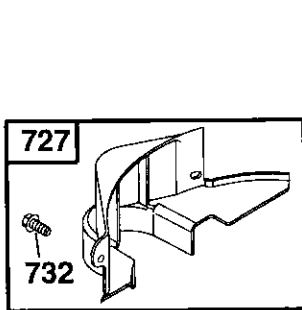
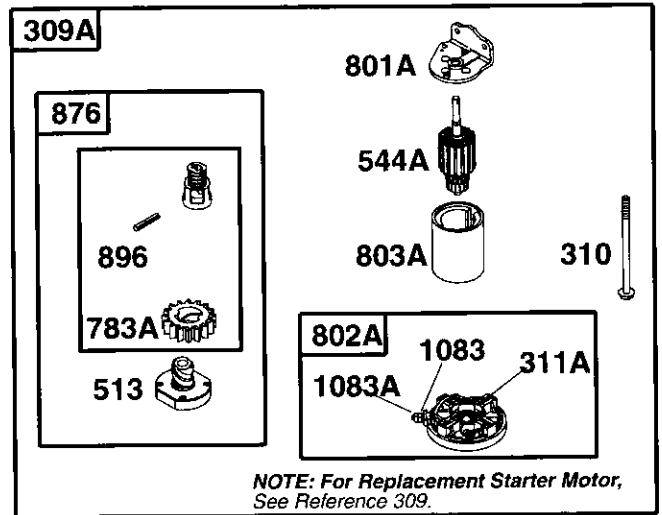
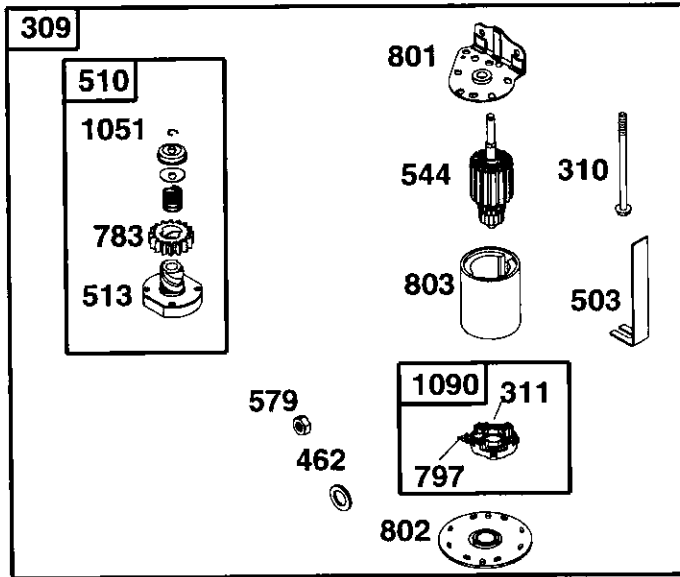

1036 LABEL-EMISSION

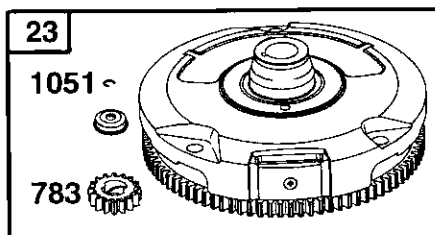
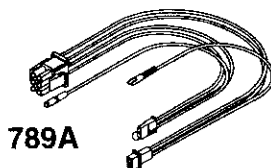
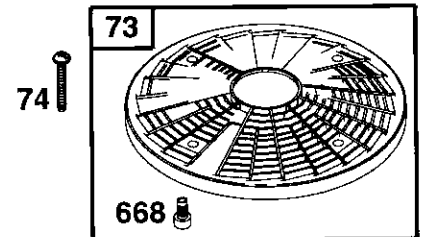
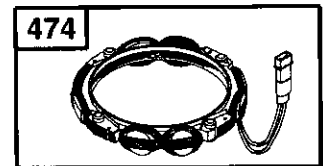
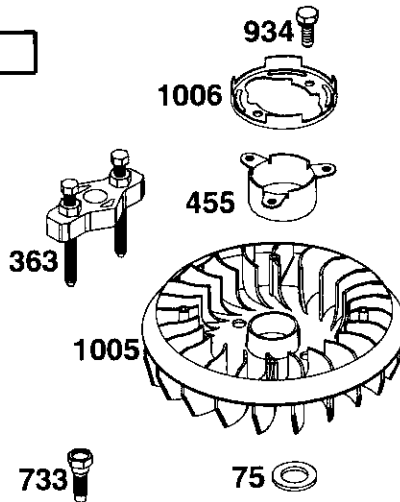
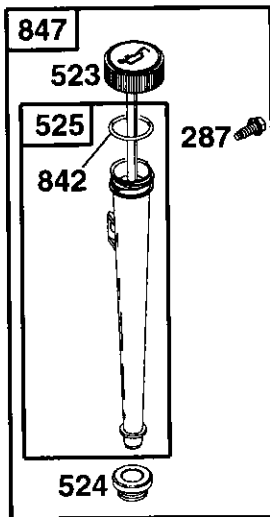

310707-0203-E1

REPAIR PARTS

TRACTOR- -MODEL NO. 917. 277031

BRIGGS & STRATTON ENGINE - - MODEL NUMBER 310707, TYPE NUMBER 0203-E1

977 CARBURETOR GASKET SET



1095 VALVE GASKET SET

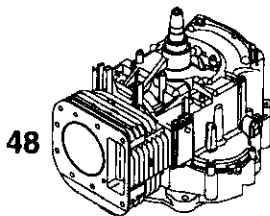
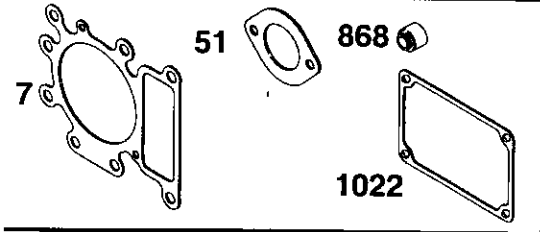

121 CARBURETOR OVERHAUL KIT

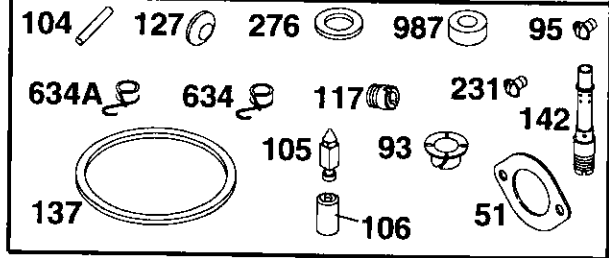

358 ENGINE GASKET SET

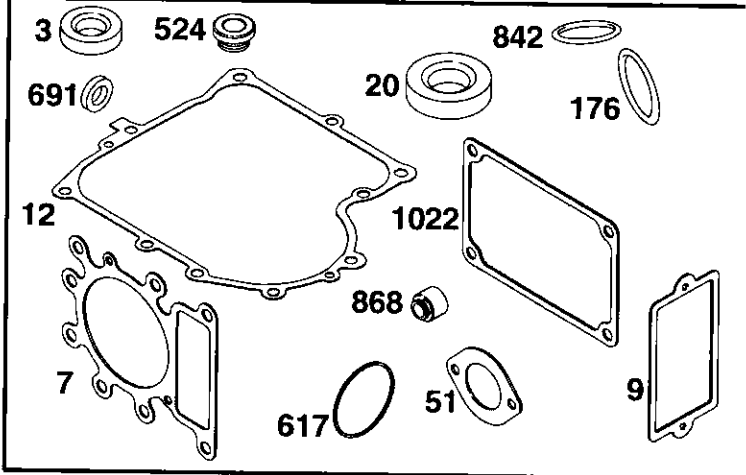

NIKKI

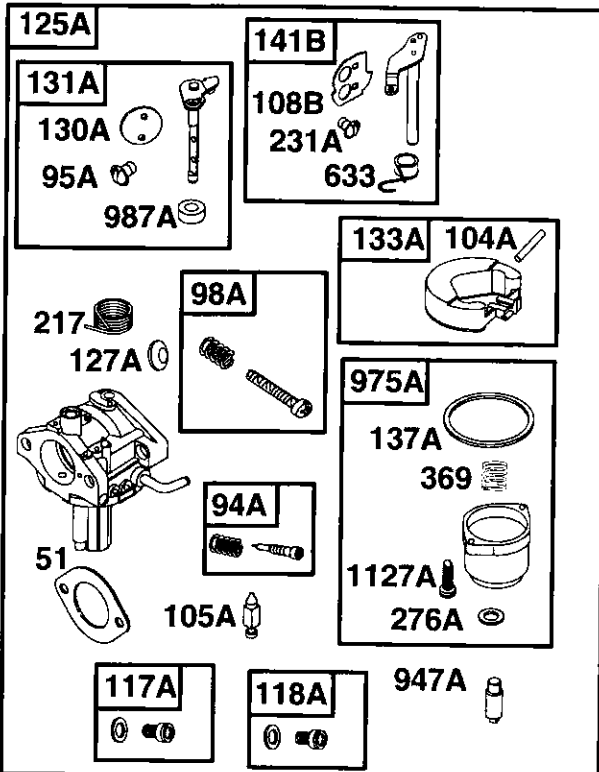

121A CARBURETOR OVERHAUL KIT

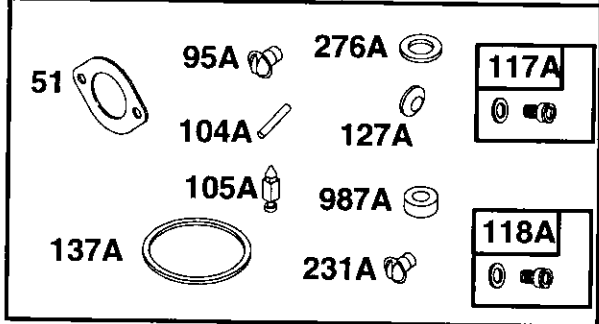

977A CARBURETOR GASKET SET

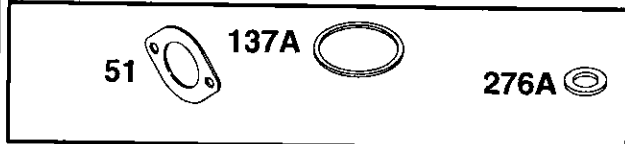

310707-0203-E1

REPAIR PARTS

TRACTOR- -MODEL NO. 917. 277031

BRIGGS & STRATTON ENGINE - - MODEL NUMBER 310707, TYPE NUMBER 0203-E1

KEY NO.	PART NO.	DESCRIPTION	KEY NO.	PART NO.	DESCRIPTION
1	690156	Cylinder Assembly	105A	694922	∅ Valve-Float Needle
2	399265	Kit-Bushing/Seal (Magneto Side)	106	690577	∅ Seat-Inlet
3	391086	• Seal-Oil (Magneto Side)	108	690464	Valve-Choke (Manual Choke)
4	494238	Sump-Engine	108A	692344	Valve-Choke(Choke-A-Matic)
5	690188	Head-Cylinder	108B	695419	Valve-Choke(Nikki Carburetor)
7	692410	+ Gasket-Cylinder Head	117	692408	∅ Jet-Main (Standard)
8	696126	Breather Assembly	117A	695415	∅ Jet-Main (Standard)
9	27803	• Gasket-Breather	118	692411	Jet-Main (High Altitude)
10	691666	Screw (Breather Assembly)	118A	695416	∅ Jet-Main (High Altitude)
11	691328	Tube-Breather	121	690191	Kit-Carburetor Overhaul
12	692226	• Gasket-Crankcase (.015" Thick, Standard)	121A	695427	Kit-Carburetor Overhaul
	692406	• Gasket-Crankcase (.005" Thick)	125	690194	Carburetor
	692405	• Gasket-Crankcase (.009" Thick)	125A	— — —	Carburetor (Nikki) (Service with Walbro Carburetor)
13	690360	Screw (Cylinder Head)	127	695005	∅ Plug-Welch
15	690946	Plug-Oil Drain	127A	690727	∅ Plug-Welch
16	690136	Crankshaft	130	691750	Valve-Throttle
20	291675	• Seal-Oil (PTO Side)	130A	695418	Valve-Throttle
22	692125	Screw (Crankcase Cover)	131	494379	Kit-Throttle Shaft
23	693557	Flywheel	131A	695421	Kit-Throttle Shaft
24	222698	Key-Flywheel	133	494381	Float-Carburetor
25	692271	Piston Assembly (Standard)	133A	694914	Float-Carburetor
	692272	Piston Assembly (.010" Oversize)	137	281165	∅‡ Gasket-Float Bowl
	692273	Piston Assembly (.020" Oversize)	137A	695426	∅‡ Gasket-Float Bowl
	692274	Piston Assembly (.030" Oversize)	141	495097	Kit-Choke Shaft (Manual Choke)
26	690162	Ring Set-Piston (Standard)	141A	495931	Kit-Choke Shaft (Choke-A-Matic)
	692164	Ring Set-Piston (.010" Oversize)	141B	695420	Kit-Choke Shaft (Nikki)
	692166	Ring Set-Piston (.020" Oversize)	142	692412	∅ Nozzle-Carburetor
	692168	Ring Set-Piston (.030" Oversize)	146	691639	Key-Timing
27	691299	Lock-Piston Pin	167	692297	Air Cleaner Stud Seal
28	498319	Pin-Piston (Standard)	176	691917	• O-Ring Seal (Air Cleaner)
	498320	Pin-Piston (.020" Oversize)	185	690958	Nut (Air Cleaner Base)
29	692419	Rod-Connecting (Standard)	186	692317	Connector-Hose
	499940	Rod-Connecting (.020" Undersize)	186A	691609	Connector-Hose
32	692852	Screw (Connecting Rod)	187	691050	Line-Fuel (Cut to Required Length)
33	495856	Valve-Exhaust	188	691693	Screw (Control Bracket)
34	495857	Valve-Intake	192	691986	Adjuster-Rocker Arm
35	691279	Spring-Valve (Intake)	202	691841	Link-Mechanical Governor
36	691279	Spring-Valve (Exhaust)	209	692208	Spring-Governor
37	690456	Guard-Flywheel	217	695409	Spring-Choke Return
40	691752	Retainer-Valve	222	694042	Bracket-Control
43	691968	Slinger-Governor/Oil	227	691374	Control Lever-Governor
45	690564	Tappet-Valve	231	691636	∅ Screw (Choke Valve)
46	692421	Camshaft	231A	690718	∅ Screw (Choke Valve)
48	692706	Short Block (311707-0028-E1 Replacement Engine)	232	691842	Spring-Governor Link
50	690193	Manifold-Intake	238	691843	Cap-Valve
51	692137	• ∅‡+ Gasket-Intake	240	394358	Filter-Fuel
53	690227	Stud (Carburetor)	265	691024	Clamp-Casing
54	691148	Screw (Intake Manifold)	267	695134	Screw (Casing Clamp)
73	690492	Screen-Rotating	276	692255	∅‡ Sealing Washer
74	691674	Screw (Rotating Screen)	276A	695410	∅‡ Sealing Washer
75	690582	Washer (Flywheel)	287	691002	Screw (Dipstick Tube)
78	690661	Screw (Flywheel Guard)	304	690844	Housing-Blower
84	690343	Plug-Breather			
93	690602	∅ Bushing-Throttle Shaft			
94	498030	Kit-Idle Mixture			
94A	695425	Kit-Idle Mixture			
95	691636	∅ Screw (Throttle Valve)			
95A	690718	∅ Screw (Throttle Valve)			
98	495800	Kit-Idle Speed			
98A	695408	Kit-Idle Speed			
104	690525	∅ Pin-Float Hinge			
104A	694918	∅ Pin-Float Hinge			
105	231855	∅ Valve-Float Needle			

RPM Settings: Low Speed: 1900-2100
High Speed: 3000-3200

- Included in Engine Gasket Set, Key. No. 358
- ∅ Included in Carburetor Overhaul Kit, Key. No. 121 and 121A
- ‡ Included in Carburetor Gasket Set, Key. No. 977 and 977A
- + Included in Valve Gasket Set, Key. No. 1095

NOTE: All component dimensions given in U.S. inches
1 inch = 25.4 mm

REPAIR PARTS

TRACTOR- -MODEL NO. 917. 277031

BRIGGS & STRATTON ENGINE - - MODEL NUMBER 310707, TYPE NUMBER 0203-E1

KEY NO.	PART NO.	DESCRIPTION	KEY NO.	PART NO.	DESCRIPTION
305	690960	Screw (Blower Housing)	789	692037	Harness-Wiring
306	690499	Shield-Cylinder	789A	695050	Harness-Wiring
307	691003	Screw (Cylinder Shield)	797	693167	Nut (Brush Retainer)
309	693551	Motor-Starter	801	691283	Cap-Drive
309A	— — —	Motor-Starter (For Replacement Starter Motor, See Reference 309)	801A	394856	Cap-Drive
310	690323	Screw (Starter Motor)	802	691286	Cap-End
311	497608	Brush Set	802A	395537	Cap-End
311A	395538	Brush Set	803	693757	Housing-Starter
333	495859	Armature-Magneto	803A	398159	Housing-Starter
334	691061	Screw (Armature Magneto)	830	691095	Stud (Rocker Arm)
337	691043	Spark Plug	842	691870	• Seal-O Ring (Dipstick Tube)
344	693675	Screw (Cable Clamp)	847	496415	Dipstick/Tube Assembly
358	690189	Engine Gasket Set	851	692424	Terminal-Spark Plug
363	19203	Flywheel Puller	868	690968	*+ Seal-Valve
369	695422	Spring-Float Bowl	875	696129	Base-Air Cleaner
383	89838	Wrench-Spark Plug	876	495877	Kit-Pinion Spring
404	691691	Washer (Governor Crank)	896	691641	Pin-Drive Retainer
445	496894	Filter-Air Cleaner Cartridge	914	690960	Screw (Rocker Cover)
455	691173	Cup-Flywheel	934	691058	Screw (Fan Retainer)
462	691261	Washer (Brush Retainer)	947	497672	Solenoid-Fuel
467	691668	Knob-Air Cleaner	947A	695423	Solenoid-Fuel
474	696459	Alternator	967	272043	Filter-Pre Cleaner
503	691532	Strap-Starter	968	691916	Cover-Air Cleaner
505	691251	Nut (Governor Control Lever)	971	692126	Screw (Air Cleaner Base)
510	693699	Drive-Starter	975	495933	Bowl-Float
513	692024	Clutch-Drive	975A	695417	Bowl-Float
523	692014	Dipstick	977	690192	Set-Carburetor Gasket
524	281370	• Seal-Dipstick Tube	977A	695428	Set-Carburetor Gasket
525	691398	Tube-Dipstick	987	691326	Ø • Seal-Throttle Shaft
544	692034	Armature-Starter	987A	690998	Seal-Throttle Shaft
544A	390837	Starter-Armature	996	690678	Carburetor Shield
552	491986	Bushing-Governor Lever	1005	695056	Fan-Flywheel
562	691119	Bolt (Governor Control Lever)	1006	690452	Retainer-Fan
559	697561	Screw (Remote Choke Stop)	1019	690180	Kit-Label
559A	693675	Screw (Remote Choke Stop)	1022	272475	*+ Gasket-Rocker Cover
579	691029	Nut (Starter Cable)	1023	691192	Cover-Rocker
601	95162	Clamp-Hose	1026	692003	Rod-Push (Intake)
614	691620	Pin-Cotter	— —	692011	Rod-Push (Exhaust)
616	692012	Crank-Governor	1029	691751	Arm-Rocker
617	692138	• O-Ring Seal (Intake Manifold)	1034	690822	Guide-Push Rod
633	695414	Seal-Choke/Throttle Shaft	1036	695700	Label-Emission
634	690801	Ø Seal-Spring Assembly (Manual Choke)	1051	691265	Retainer-Brush
634A	690802	Ø Seal-Spring Assembly (Choke-A-Matic)	1058	275038	Owner's Manual
635	691909	Boot-Spark Plug	1083	691626	Nut (Starter Terminal)
668	691323	Spacer	1083A	690958	Nut (Starter Terminal)
691	692407	• Seal-Governor Shaft	1090	691293	Retainer-Brush
692	690572	Spring-Detent	1091	691333	Cap-Limiter
697	690372	Screw (Drive Cap)	1095	690190	Valve Gasket Set
711	690703	Screw (Carburetor Shield)	1119	691183	Screw (Alternator)
718	690959	Pin-Locating	1127	691657	Screw (Float Bowl)
727	490324	Cover-Starter Drive	1127A	695407	Screw (Float Bowl)
729	691335	Clip-Wire			
729A	691224	Clip-Wire			
732	691002	Screw (Starter Drive Cover)			
733	691658	Screw (Crankshaft Extension)			
741	691284	Gear-Timing			
757	691714	Link-Counterweight			
758	692423	Counterweight			
759	691239	Pin-Counterweight			
761	691096	Screw (Counterweight)			
783	693713	Gear-Pinion			
783A	693059	Gear-Pinion			

RPM Settings: Low Speed: 1900-2100

High Speed: 3000-3200

• Included in Engine Gasket Set, Key. No. 358

Ø Included in Carburetor Overhaul Kit, Key. No. 121 and 121A

‡ Included in Carburetor Gasket Set, Key. No. 977 and 977A

+ Included in Valve Gasket Set, Key. No. 1095

NOTE: All component dimensions given in U.S. inches
1 inch = 25.4 mm

LIMITED WARRANTY ON CRAFTSMAN RIDING EQUIPMENT

For two (2) years from the date of purchase, if this Craftsman Riding Equipment is maintained, lubricated and tuned up according to the instructions in the owner's manual, Sears will repair or replace free of charge any parts that are found to be defective in material or workmanship according to the guidelines of coverage listed below. Sears will also provide free labor for these applicable warranted parts for the two full years. During the first 30 days of purchase, there will be no charges to service the product at your home for issues covered by this warranty. (See exclusions below). For your convenience, IN HOME warranty service will still be available after the first 30 days of purchase, but a trip charge will apply. This charge will be waived if the Craftsman product is dropped off at an authorized Sears location. For the nearest authorized Sears location, please call 1-800-4-MY-HOME®. This warranty applies only while this product is within the United States.

This Warranty does not cover:

- Expendable items which become worn during normal use, including but not limited to blades, spark plugs, air cleaners, belts, and oil filters.
- Standard Maintenance Servicing, oil changes, or tune-ups
- Tire replacement or repair caused by punctures from outside objects, such as nails, thorns, stumps, or glass.
- Repairs necessary because of operator abuse, including but not limited to, damage caused by towing objects beyond the capability of the riding equipment, impacting objects that bend the frame or crankshaft, or over-speeding the engine.
- Repairs necessary because of operator negligence, including but not limited to, electrical and mechanical damage caused by improper storage, failure to use the proper grade and amount of engine oil, failure to keep the deck clear of flammable debris, or failure to maintain the equipment according to the instructions contained in the owner's manual.
- Engine (fuel system) cleaning or repairs caused by fuel determined to be contaminated or oxidized (stale). In general, fuel should be used within 30 days of its purchase date.
- Normal deterioration and wear of the exterior finishes, or product label replacement.
- Riding equipment used for commercial or rental purposes.

LIMITED WARRANTY ON BATTERY

For ninety (90) days from date of purchase, if any battery included with this riding equipment proves defective in material or workmanship and our testing determines the battery will not hold a charge, Sears will replace the battery at no charge. During the first 30 days of purchase, there will be no charges to replace the battery at your HOME. After the first 30 days, for your convenience, IN-HOME warranty service will still be available but a trip charge will apply. This charge will be waived if the Craftsman product is dropped off at an authorized Sears location. For the nearest authorized Sears location, please call 1-800-4-MY-HOME®.

This battery warranty applies only while this product is within the United States.

This warranty gives you specific legal rights, and you may also have other rights, which vary, from state to state.

Sears, Roebuck and Co., Dept. 817WA, Hoffman Estates, IL 60179

CRAFTSMAN®