

REPAIR PARTS MANUAL
MODEL NO. 277040
Lawn Tractor

177H * 6 Hyd
42"



HOW TO USE THIS MANUAL

This manual is designed to provide the customer with a means to identify the parts on his/her tractor when ordering repair parts. The illustrations may or may not represent the actual assemblies; therefore, it is not recommended to use this manual as a guide to assemble or disassemble the tractor. Some hardware and parts are drawn larger in order to more readily identify them.

Each tractor has its own model number.

The model number for your tractor can be found on the fender under the seat.

When ordering parts, always give the following information:

- Product - "Tractor"
- Model Number - "277040"
- Part Number
- Part Description

TABLE OF CONTENTS

SCHEMATIC	3
ELECTRICAL	4-5
CHASSIS	6-7
DRIVE	8-9
STEERING	10-11
ENGINE	12-13
SEAT	14
DECALS	15
MOWER LIFT	16-17
MOWER DECK	18-19
TRANSAXLE	20-21
ENGINE BREAKDOWN	22-27
WARRANTY	28

TRACTOR- -MODEL NO. 917. 277040

SCHEMATIC

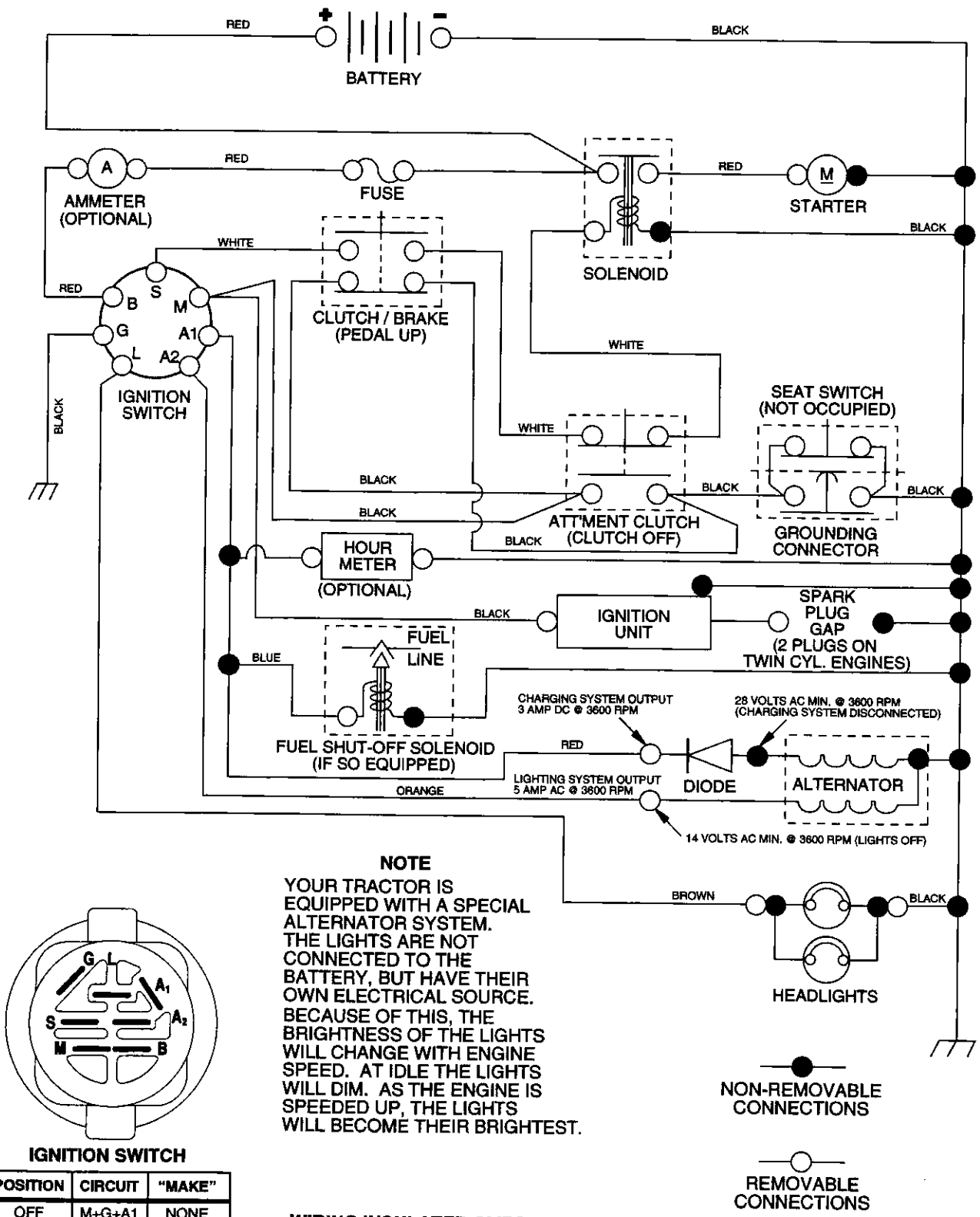

REPAIR PARTS

TRACTOR- -MODEL NO. 917. 277040

ELECTRICAL

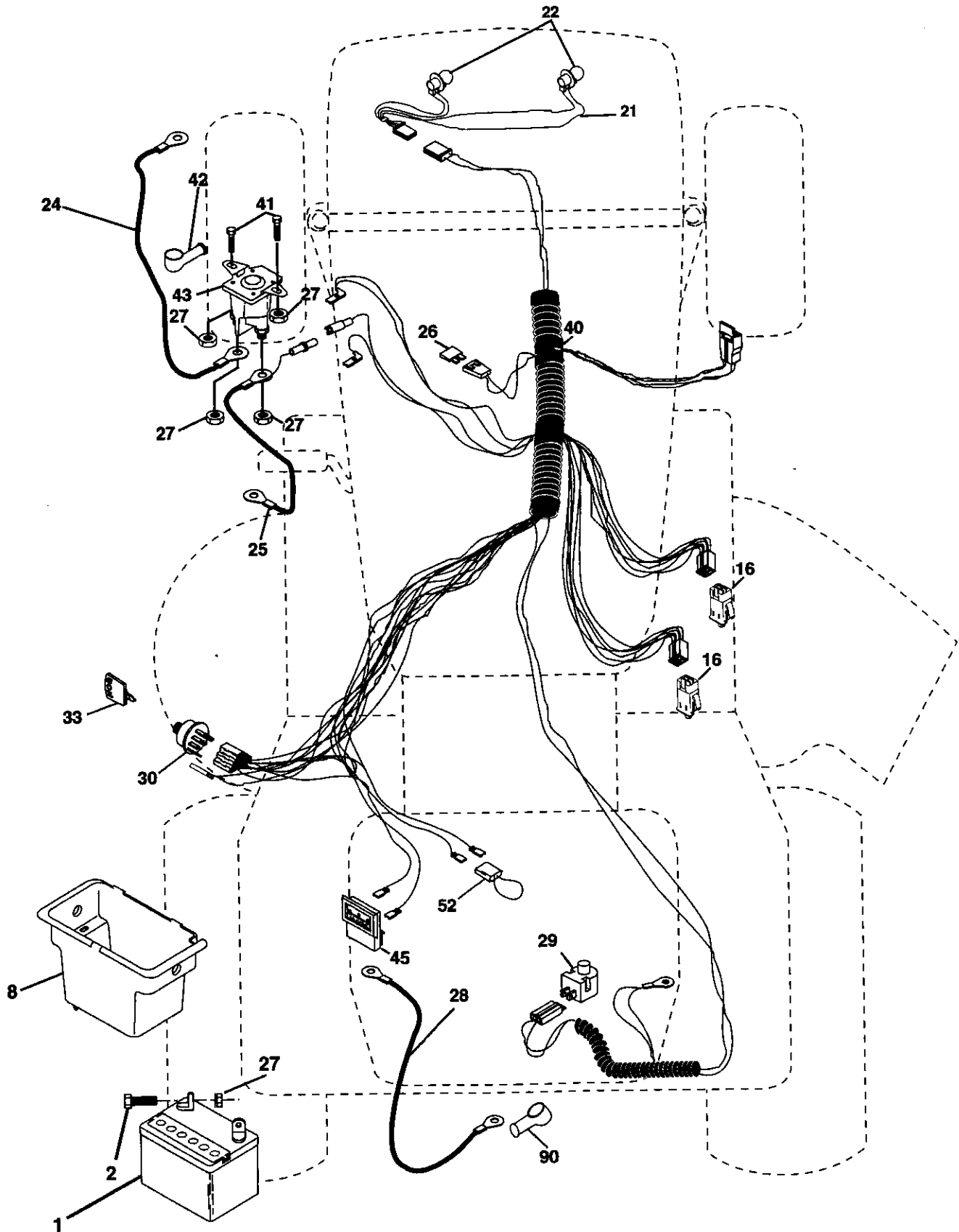

REPAIR PARTS

TRACTOR- -MODEL NO. 917. 277040

ELECTRICAL

KEY NO.	PART NO.	DESCRIPTION
1	163465	Battery
2	74760412	Bolt Hex Hd 1/4-20unc x 3/4
8	176689	Box Battery Fender
16	176138	Switch, Interlock
21	175688	Harness Asm Light W/4152j
22	4152J	Bulb Light #1156
24	4799J	Cable Battery 6 Ga 11" red
25	146147	Cable Battery 6 Ga w/16 wire red
26	175158	Fuse 20 AMP
27	73510400	Nut, Keps Hex 1/4-20 UNC
28	4207J	Cable Ground 6 Ga 12" black
29	121305X	Switch Plunger Nc Gray
30	175566	Switch Ign
33	140403	Key Ign Molded Craftsman
40	179720	Harness Ign
41	71110408	Bolt Blk. Fin Hex 1/4-20 Unc x 1/2
42	131563	Cover Terminal Red
43	178861	Solenoid
45	121433X	Ammeter Rectangular 6 Amp
52	141940	Protection Wire Loop
90	180449	Cover Terminal Battery

NOTE: All component dimensions give in U.S. inches
1 inch = 25.4 mm

REPAIR PARTS

TRACTOR- -MODEL NO. 917. 277040

CHASSIS AND ENCLOSURES

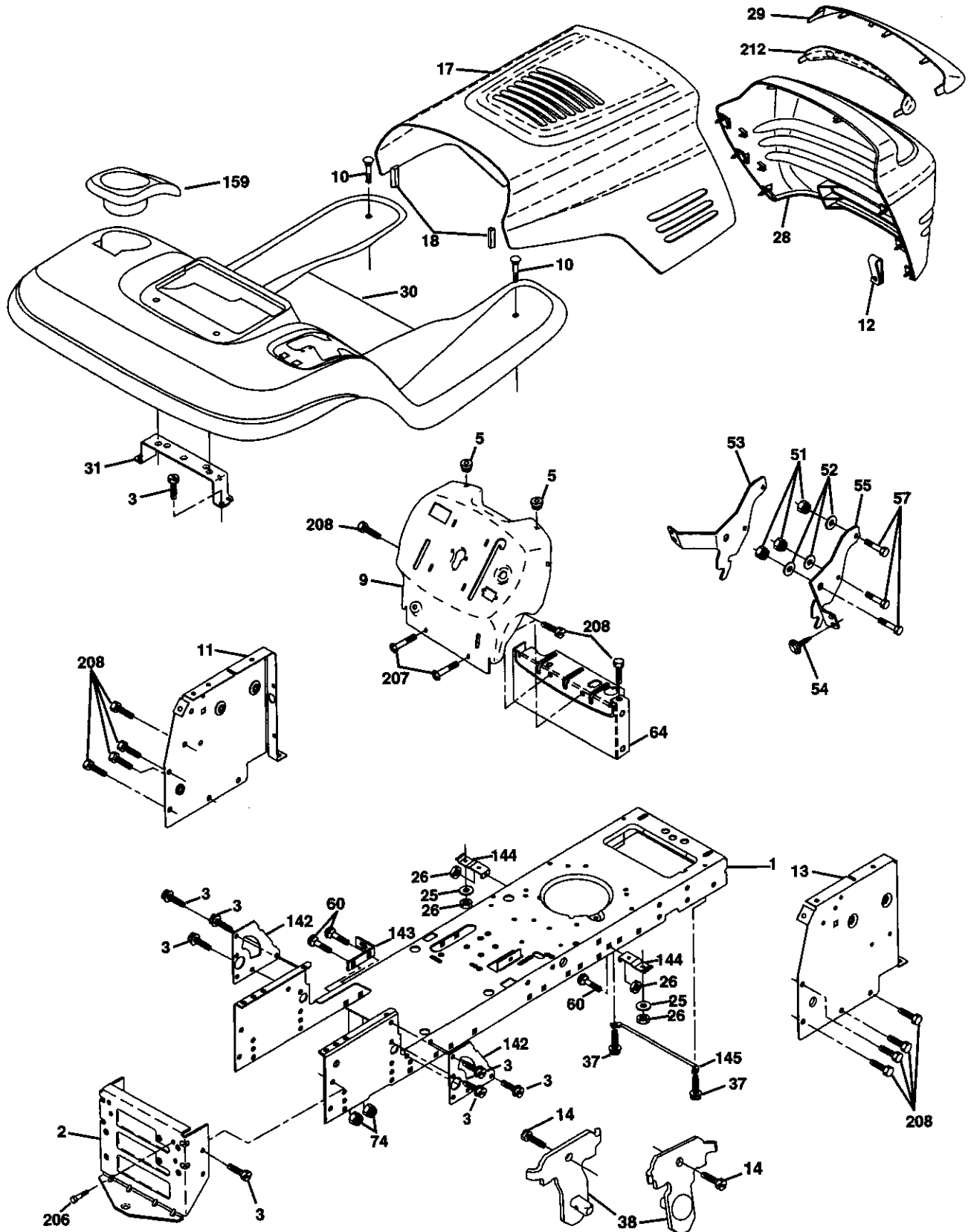

REPAIR PARTS

TRACTOR- -MODEL NO. 917. 277040

CHASSIS AND ENCLOSURES

KEY NO.	PART NO.	DESCRIPTION
1	174619	Chassis
2	176554	Drawbar
3	17060612	Screw 3/8-16 x 3/4
5	155272	Bumper Hood/Dash
9	168337X012	Dash.
10	STD533710	Bolt, Carriage 3/8-16 x 3/4
11	174996	Panel, Dash, L.H.
12	145660	Clip Tinnerman Grille P/L
13	172105X010	Panel, Asm. SLKSCR Dash R.H.
14	17490608	Screw Thdrol 3/8-16 x 1/2
17	144983X558	Hood Assembly
18	126938X	Bumper Hood
25	19131312	Washer 13/32 x 13/16 x 12 Gauge
26	STD541437	Nut, Lock Hex W/Ins. 3/8-16 UNC
28	178987X558	Grille w/Lens Asm.
29	155217X599	Lens, Grille
30	175692X558	Fender
31	139976	Bracket, Fender Support
37	17490508	Screw Thdrol 5/16-18 x 1/2 TYT
38	175710	Bracket Asm Pivot
51	73800400	Nut Lock w/Insert 1/4-20 UNC
52	19091416	Washer 9/32 x 7/8 x 16 Ga.
53	145201	Bracket Grille Pickoff LH
54	161464	Screw Hex WSHD 8-18 x 7/8
55	145202	Bracket Grille Pickoff RH
57	STD522507	Bolt, Fin Hex 1/4-20 UNC x .75
60	STD533707	Bolt Rdhd Sqnk 3/8-16 UNC x 3/4
64	154798	Dash Lower STLT
74	STD541437	Nut, Crownlock 3/8-16 UNC
142	175702	Plate Reinforcement STLT
143	154966	Bracket Swaybar Chassis
144	175582	Bracket Pnt Footrest STLT
145	156524	Rod Pivot Chassis/Hood
159	155123X428	Cupholder
206	170165	Bolt Shoulder 5/16-18 TT
207	17670508	Screw Thdrol 5/8-18 x 1/2
208	17670608	Screw Thdrol 3/8-16 x 1/2
212	165919	Insert Lens Reflective
--	5479J	Plug, Button

NOTE: All component dimensions give in U.S. inches
1 inch = 25.4 mm

REPAIR PARTS

TRACTOR- -MODEL NO. 917. 277040

GROUND DRIVE

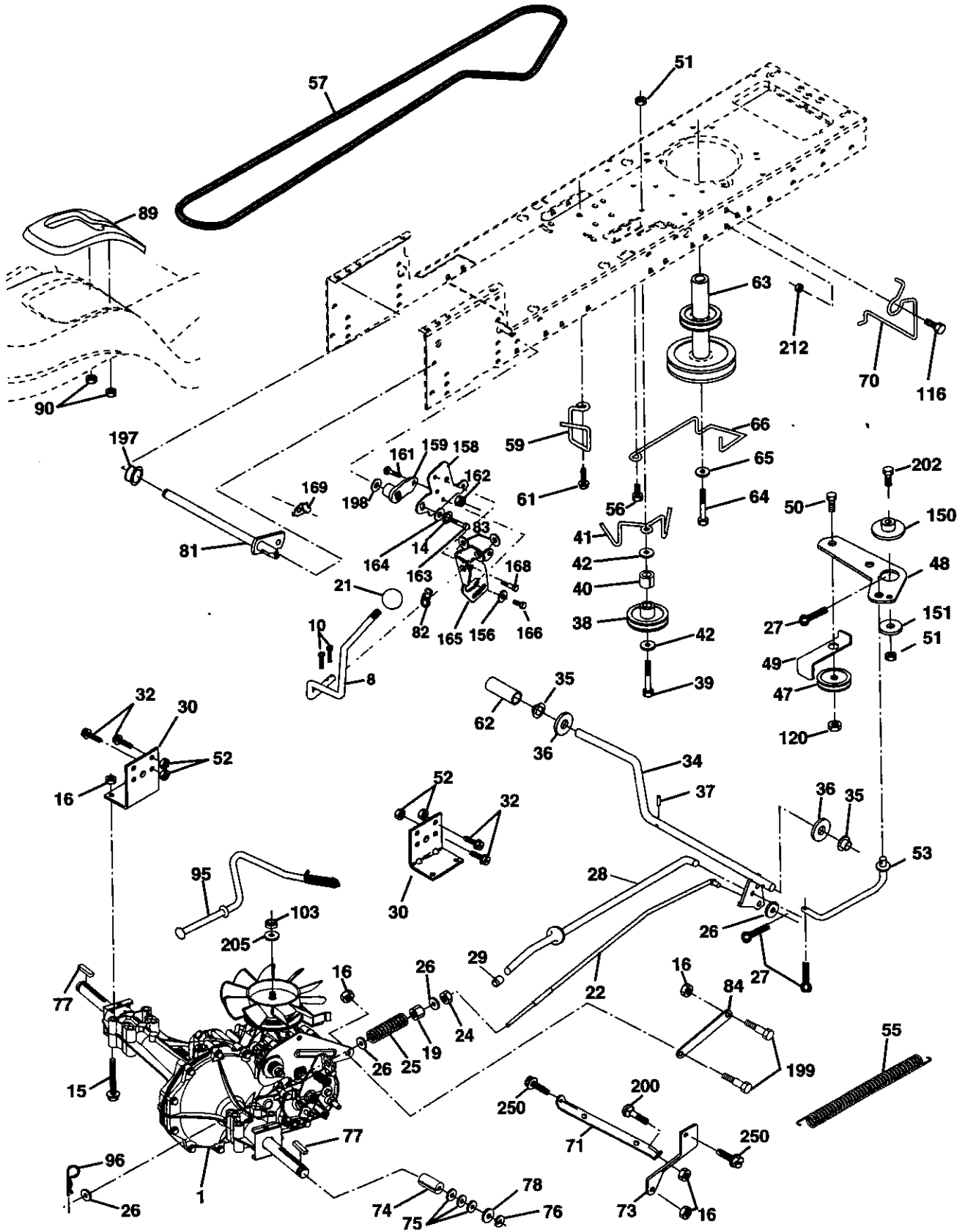

REPAIR PARTS

TRACTOR- -MODEL NO. 917. 277040

GROUND DRIVE

KEY NO.	PART NO.	DESCRIPTION	KEY NO.	PART NO.	DESCRIPTION
1	-----	Transmission (See Breakdown) Hydro Gear Model 322-0510	71	169183	Strap, Torque, Lh
8	165866	Rod, Shift	73	169182	Strap, Torque, Rh
10	STD561210	Pin, Cotter 1/8 x 1	74	137057	Spacer, Axle
14	STD551125	Washer Lock 1/4	75	121749X	Washer 25/32 x 1-1/4 x 16 Ga.
15	74490544	Bolt Hex Flghd 5/16-18 Gr. 5	76	12000001	Ring, E
16	73800500	Nut, Lock Hex w/Ins 5/16-18 UNC	77	123583X	Key, Square
19	73800600	Nut Lock Hex w/Ins 3/8-16	78	121748X	Washer 25/32 x 1-5/8 x 16 Ga.
21	130564	Knob	81	165596	Shaft Asm Cross
22	169498	Rod, Brake	82	165711	Spring, Torsion
24	73350600	Nut	83	19171216	Washer 17/32 x 3/4 x 16 Ga.
25	106888X	Spring, Rod, Brake	84	169843	Link Transaxle
26	19131316	Washer 13/32 x 13/16 x 16 Ga.	89	164890X428	Console, Shift
27	STD561210	Pin, Cotter 1/8 x 3/4	90	124346X	Nut Self-Thd Wshd 1/4
28	175765	Rod, Parking Brake	95	170201	Control Asm Bypass Hydro
29	71673	Cap, Parking Brake	96	STD624003	Spring, Retainer 1"
30	174973	Bracket, Transmission	103	73940800	Nut, Hex Jam Toplock 1/2-20 UNF
32	74760512	Bolt Hex 5/16-18 UNC x 3/4	116	72140608	Bolt Rdhd Sq Neck 3/8-16 x 1
34	175578	Shaft, Foot Pedal	120	73900600	Nut Lock Flg 3/8-16
35	120183X	Bearing, Nylon	150	175456	Spacer Retainer
36	19211616	Washer	151	19133210	Washer 13/32 x 2 x 10
37	1572H	Pin, Roll	156	166002	Washer 5/16 x 1.0 x 1.25
38	179114	Pulley, Composite	158	165589	Bracket Shift Mount
39	74760648	Bolt	159	165494	Hub Tapered Flange Shift
41	175556	Keeper, Belt, Idler	161	72140406	Bolt Rdhd Sqnk 1/4-20 x 3/4 Gr. 5
47	127783	Pulley, Idler, V-Belt	162	73680400	Nut Crownlock 1/4-20 Unc
48	154407	Bellcrank Clutch Grnd Drustl	163	74780416	Bolt Hex Fin 1/4-20 x 1
49	123205X	Retainer, Belt	164	19091010	Washer 5/8 x .281 x 10 Ga.
50	74760624	Bolt	165	165623	Bracket Pivot Lever
51	STD541437	Nut	166	166880	Screw 5/16 x 1.0 x .125
52	STD541431	Nut Crownlock 5/16-18	168	165492	Bolt Shoulder 5/16-18 x .561
53	105710X	Link, Clutch	169	165580	Plate Fastener Cross Shaft
55	105709X	Spring, Return, Clutch	197	169613	Nyliner Snap-In
56	17060620	Screw 3/8-16 x 1-1/4	198	169593	Washer Nyliner
57	140294	V-Belt, Drive	199	169612	Bolt Shoulder 5/16-18 Unc
59	169691	Keeper, Belt, Center	200	72140508	Bolt RdHd Sqnk 5/16-18 Unc x 1
61	17120614	Screw 3/8-16 x .875	202	72110614	Bolt Carr. Sh 3/8-16 x 1-3/4 Gr. 5
62	8883R	Cover, Pedal	205	19171616	Washer 17/32 x 1 x 16 Ga.
63	180219	Pulley, Engine	212	145212	Nut Hex Flange Lock
64	71170764	Bolt Hex 7/16 x 4 Gr. 5	250	17060612	Screw 3/8-16 x 3/4
65	10040700	Washer			
66	154778	Keeper, Belt Engine Hydro			
70	180218	Guide, Belt, Mower Drive RH			

NOTE: All component dimensions given in U.S. inches
1 inch = 25.4 mm

REPAIR PARTS

TRACTOR- -MODEL NO. 917. 277040

STEERING ASSEMBLY

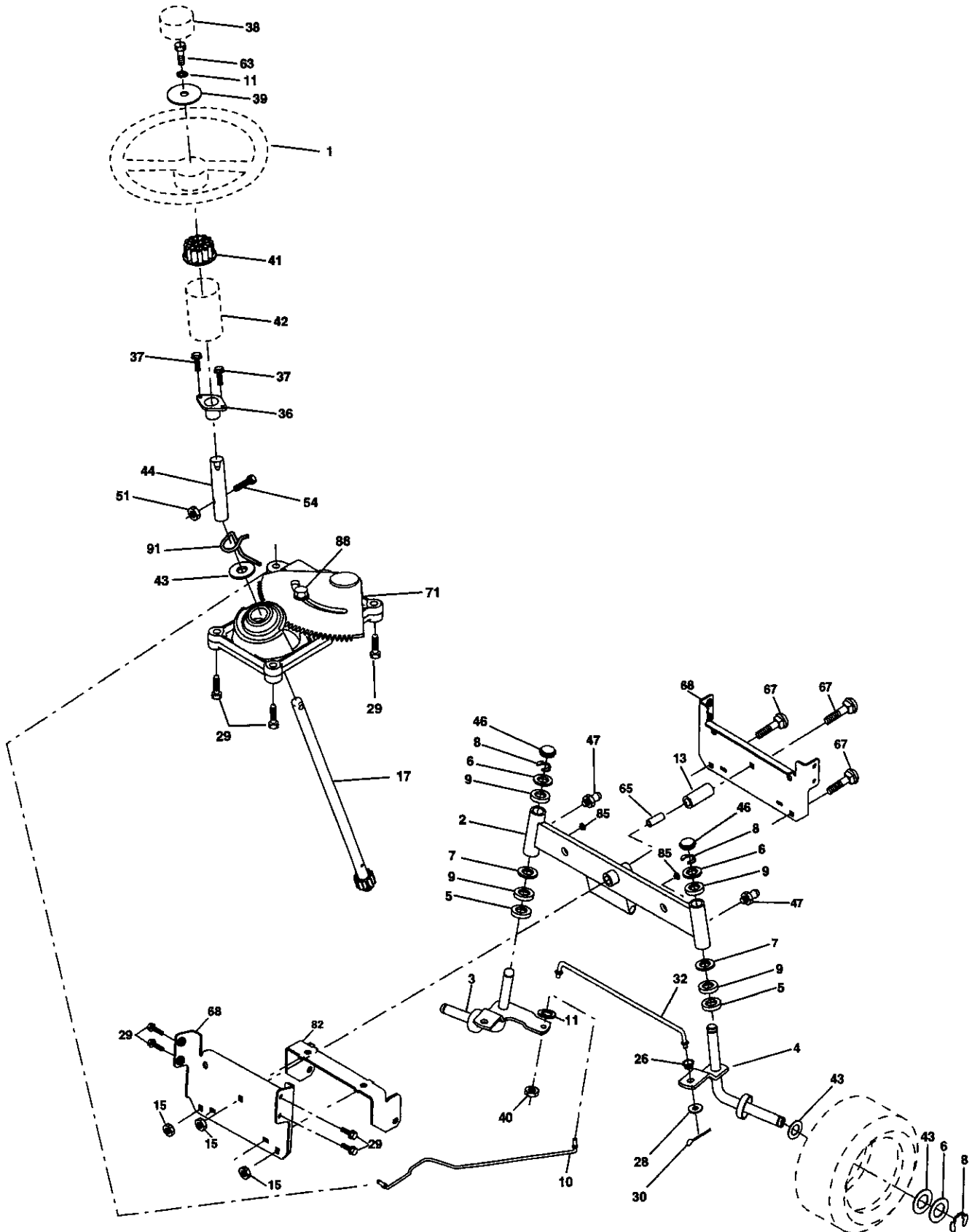

REPAIR PARTS

TRACTOR- -MODEL NO. 917. 277040

STEERING ASSEMBLY

KEY NO.	PART NO.	DESCRIPTION
1	139768	Steering Wheel
2	175131	Front Axle Assembly
3	169840	Spindle Assembly, L.H.
4	169839	Spindle Assembly, R.H.
5	6266H	Bearing, Race, Thrust, Hardened
6	121748X	Washer 25/32 x 1-5/8 x 16 Gauge
7	19272016	Washer 27/32 x 1-1/4 x 16 Gauge
8	12000029	Ring, Klip
9	3366R	Bearing, Steering Column
10	175121	Link, Drag
11	STD551137	Washer, Lock
13	136518	Spacer, Bearing, Front Axle
15	145212	Nut Lock Hex Flange
17	177876	Shaft Assembly, Steering
26	126847X	Bushing, Link, Drag
28	19131416	Washer 13/32 x 7/8 x 16 Gauge
29	17060612	Screw 3/8-16 x 3/4
30	STD561210	Pin, Cotter
32	130465	Rod, Tie
36	155099	Bushing, Steering
37	152927	Screw TT #10-32 x 5 x 3/8 Flange
38	139769	Cap Wheel Steer OPP Blk
39	19133812	Washer 13/32 x 2-3/8 x 12 Gauge
40	STD541537	Nut Lock Center 3/8-24 UNF
41	100711L	Adaptor, Steering Wheel
42	145054X428	Boot, Steering Dash P/L Mtl Blk
43	121749X	Washer 25/32 x 1-1/4 x 16 Gauge
44	153720	Extension Steering Non-Adjust
46	121232X	Cap, Spindle
47	6855M	Fitting, Grease
51	STD541431	Nut Lock Hx W/Ins 5/16-18 UNC
54	74780520	Bolt Fin Hex 5/16-18 UNC x 1-1/4
63	STD523710	Bolt Fin Hex 3/8-16 unc. x 1 Gr. 5
65	160367	Spacer Brace Axle
67	72140618	Bolt Rdhd Sq 3/8-16 x 2-1/4
68	169827	Brace Axle
71	175146	Steering Asm.
82	169835	Bracket Susp Chassis Front
85	133835	Fastener Christmas Tree
88	175118	Bolt Shoulder 7/16-20
91	175553	Clip Steering

NOTE: All component dimensions given in U.S. inches
1 inch = 25.4 mm

REPAIR PARTS

TRACTOR- -MODEL NO. 917. 277040

ENGINE

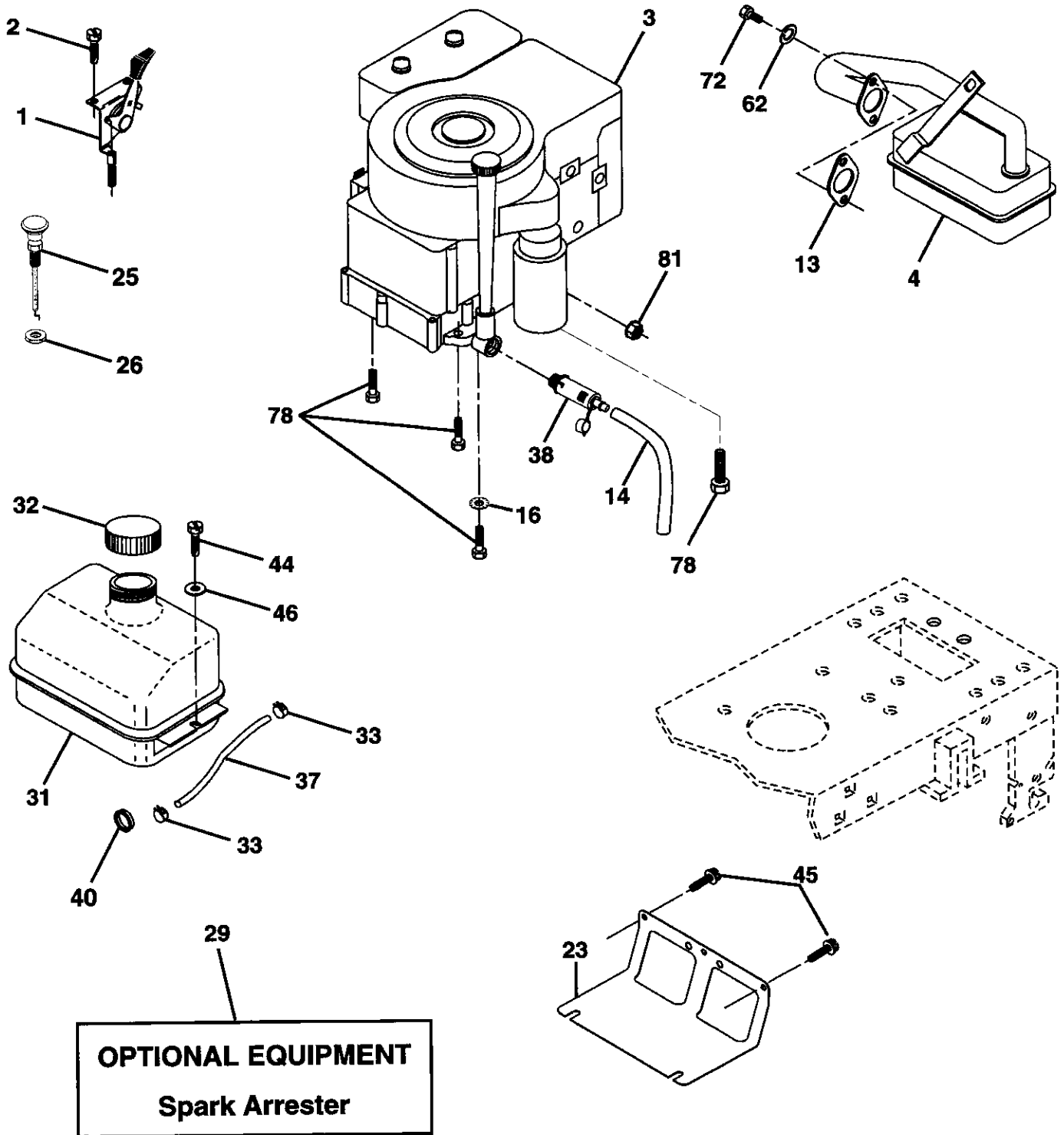

REPAIR PARTS

TRACTOR- -MODEL NO. 917. 277040

ENGINE

KEY NO.	PART NO.	DESCRIPTION
1	170545	Control Throttle/Choke
2	17720408	Screw Hex Thd Cut 1/4-20 x 1/2
3	-----	Engine (See Breakdown) Briggs Model 310707-0203-E1
4	137352	Muffler Exhaust B&S Lt
13	165291	Gasket 1 313 Id Tin Plated
14	148456	Tube Drain Oil
16	STD551237	Washer Lock Ext Tooth 3/8
23	169837	Shield BRN/DBR Guard
25	180945	Control Choke
26	73920600	Nut Keps 3/8-24 Unf
29	137180	Arrestor Spark
31	109202X	Tank Fuel 1 25 Fr
32	158990	Cap Asm Fuel W/sym Vented
33	123487X	Clamp Hose Blk
37	137040	Line Fuel 20"
38	148315	Plug Oil Drain
40	124028X	Bushing Snap Nyl Blk Fuel Line
44	17670412	Screw Hexwsh Thdrol 1/4-20x3/4
45	17000612	Screw Hexwsh Thdr 3/8-16 x 3/4
46	19091416	Washer 9/32 X 7/8 X 16ga
62	STD551131	Washer Lock Hvy Hlcl Spr 5/16
72	71070512	Screw Hexhd Cap 5/16-18x3/4
78	17060620	Screw 3/8-16x1-1/4
81	73510400	Nut Keps Hex 1/4-20unc

NOTE: All component dimensions given in U.S. inches
1 inch = 25.4 mm

REPAIR PARTS

TRACTOR- -MODEL NO. 917. 277040

SEAT ASSEMBLY

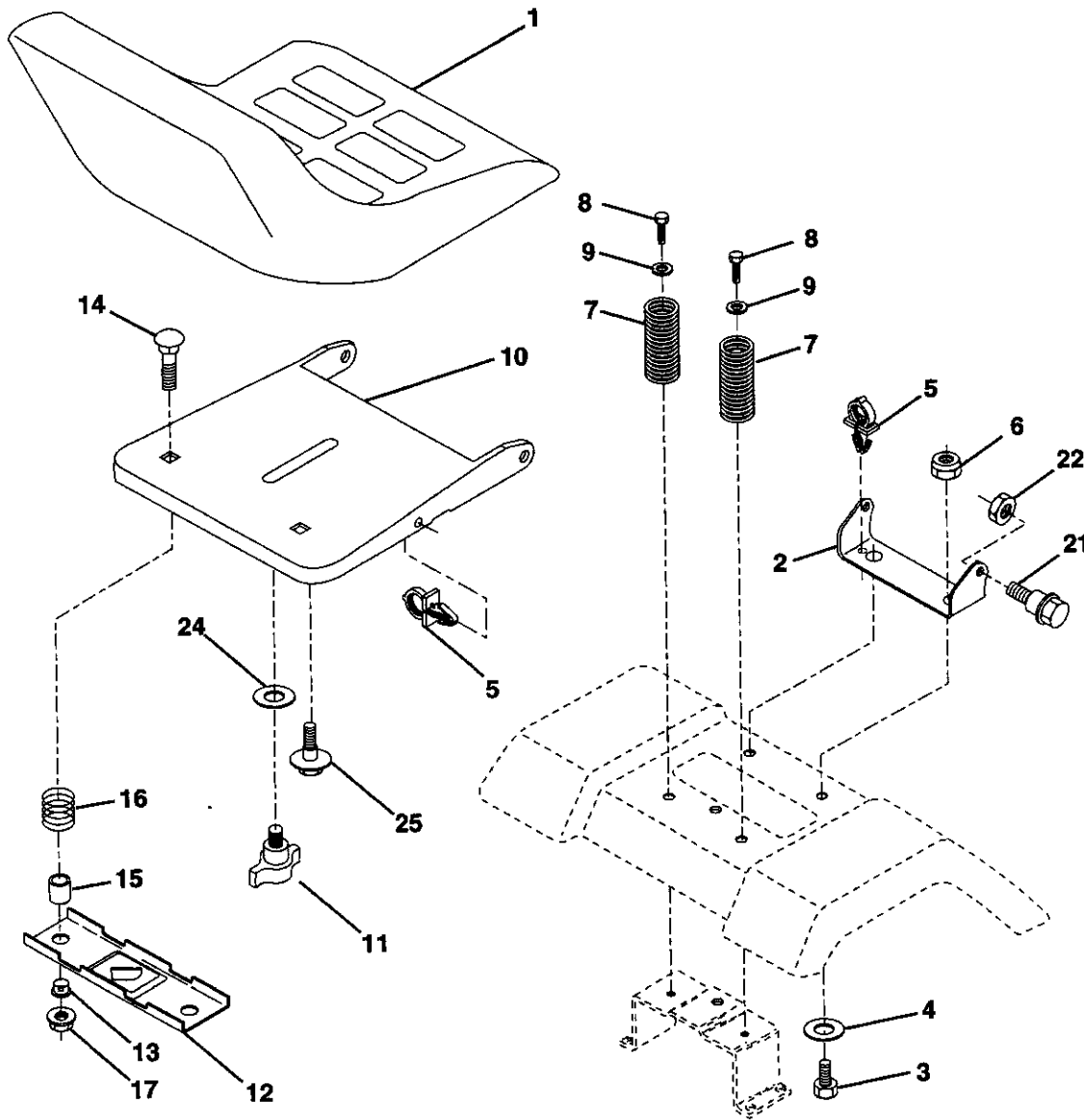

KEY NO.	PART NO.	DESCRIPTION
1	140122	Seat 3350 Blk/blk Craftsman
2	140551	Bracket Pnt Pivot Seat (blk)
3	71110616	Bolt Fin Hex 3/8-16unc X 1
4	19131610	Washer 13/32 X 3/4 X 10 Ga
5	145006	Clip Push In Hinged
6	STD541437	Nut Hex Lock w/Ins 3/8-16 Unc
7	124181X	Spring Seat Cprsn 2 250 Blk Zi
8	17000616	Screw 3/8-16 X 1 -1/2
9	19131614	Washer 13/32 X 1 X 14 Ga
10	174894	Pan Pnt Seat (blk)
11	166369	Knob Seat
12	121246X	Bracket Pnt Mounting Switch

KEY NO.	PART NO.	DESCRIPTION
13	121248X	Bushing Snap Blk Nyl 50 Id
14	72050412	Bolt Rdhd Sht Nk 1/4-20x1-1/2
15	134300	Spacer Split 28 X 96 Zinc
16	121250X	Spring Cprsn 1 27 Blk Pnt
17	123976X	Nut Lock 1/4 Lge Flg Gr 5 Zinc
21	171852	Bolt Shoulder 5/16-18 Unc-2A
22	STD541431	Nut Hex Lock w/Ins 5/16-18
24	19171912	Washer 17/32 X 1-3/16 X 12 Ga
25	127018X	Bolt Shoulder 5/16-18 X 62

NOTE: All component dimensions given in U.S. inches
1 inch = 25.4 mm

REPAIR PARTS

TRACTOR- -MODEL NO. 917. 277040

DECALS

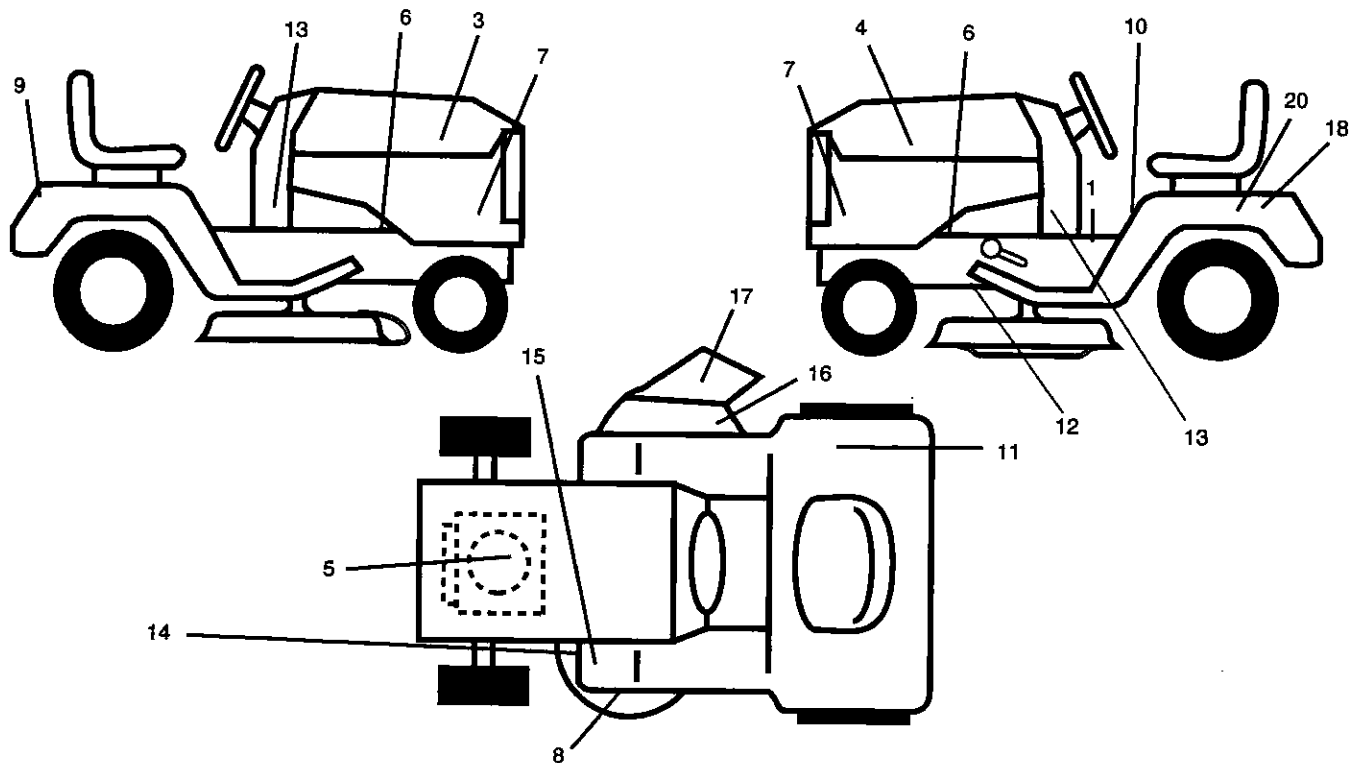

KEY NO.	PART NO.	DESCRIPTION
1	140837	Decal, Brake Parking
3	171696	Decal, Hood Rh
4	171697	Decal, Hood Lh
5	181450	Decal, Hp Engine
6	159736	Decal, Chass Hot Muffler
7	177253	Decal, Hood Side
8	172331	Decal Mower
9	163204	Decal, Fender Craftsman
10	145498	Decal, Read Owners
11	180432	Decal, 100 DB/CE
12	146046	Decal, V-belt Dr Sch
13	181702	Decal, Dash, Panel
14	160396	Decal, V-belt Schematic

KEY NO.	PART NO.	DESCRIPTION
15	159737	Decal Brake/Clutch
16	182166	Decal, Internation Cuttinger
17	179128	Decal, Deck "B" 42"
18	138047	Decal, Battery
20	145005	Decal, Battery Dngr/Psn Eng
--	169210	Decal, Bypass
--	138311	Decal, Lift Handle
--	165800X428	Pad, Footrest LH STLT
--	165799X428	Pad, Footrest RH STLT
--	162598	Decal, Draw Bar
--	182625	Manual, Operator's (Euro)
--	182626	Manual, Operator's (Scand)
--	182627	Manual, Parts

WHEELS & TIRES

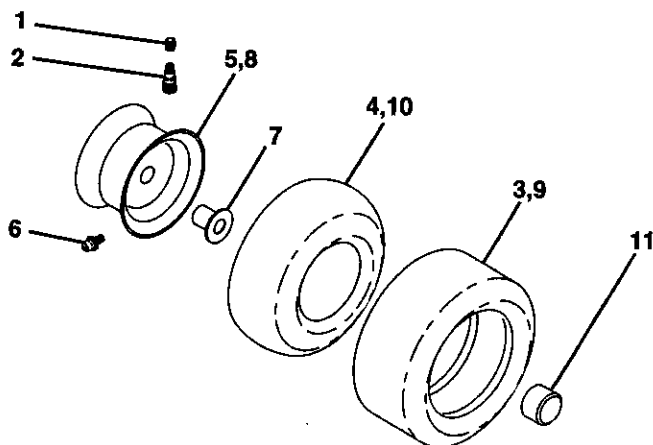

KEY NO.	PART NO.	DESCRIPTION
1	59192	Cap Value Tire
2	65139	Stem Value
3	106222X	Tire F Ts 15 X 6 0 - 6 Service
4	59904	Tube Inner Front #35060
5	106732X427	Rim Asm 6"front White Service
6	278H	Fitting Grease
7	9040H	Bearing Flange
8	106108X427	Rim Asm 8"rear White Service
9	106268X	Tire R Ts 18x9 5-8 Service
10	7152J	Tube Rear 9 5 X 8 Service
11	104757X428	Cap Axle Blk 1 50 X 1 00
--	144334	Sealant, Tire (10 oz. tube)

NOTE: All component dimensions given in U.S. inches
1 inch = 25.4 mm

REPAIR PARTS

TRACTOR- -MODEL NO. 917. 277040

LIFT ASSEMBLY

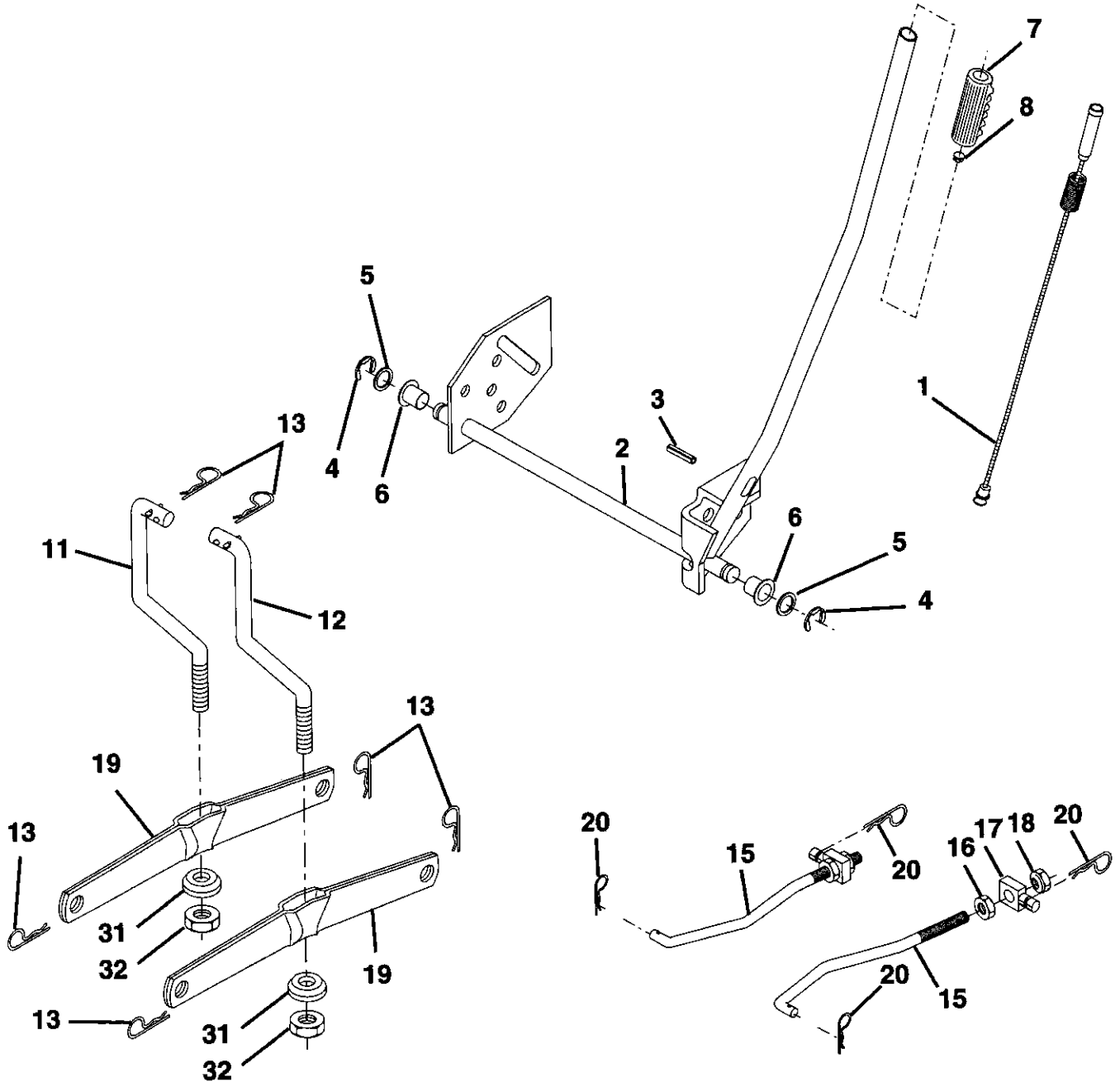

REPAIR PARTS

TRACTOR- -MODEL NO. 917. 277040

LIFT ASSEMBLY

KEY NO.	PART NO.	DESCRIPTION
1	159460	Washer Asm Inner Spring W/Plunger
2	159471	Shaft Asm. Lift RH
3	105767X	Pin Groove
4	12000002	E Ring #5133-62
5	19211621	Washer 21/32 x 1 x 21 Ga.
6	120183X	Bearing Nylon
7	125631X	Grip Handle Fluted
8	122365X	Button Plunger Read
11	139865	Link Asm Lift L.H.
12	139866	Link Asm Lift R.H.
13	STD624008	Retainer Spring
15	173288	Link Front
16	73350800	Nut Jam Hex 1/2-13 Unc
17	175689	Trunnion Blk Zinc
18	73800800	Nut Lockw/wsh 1/2-13 Unc
19	139868	Arm Suspension Mower
20	163552	Retainer Spring
31	169865	Bearing, Pvt. Lift.
32	73540600	Nut Crownlock 3/8-24

NOTE: All component dimensions given in U.S. inches
1 inch = 25.4 mm

REPAIR PARTS

TRACTOR- -MODEL NO. 917. 277040

MOWER DECK

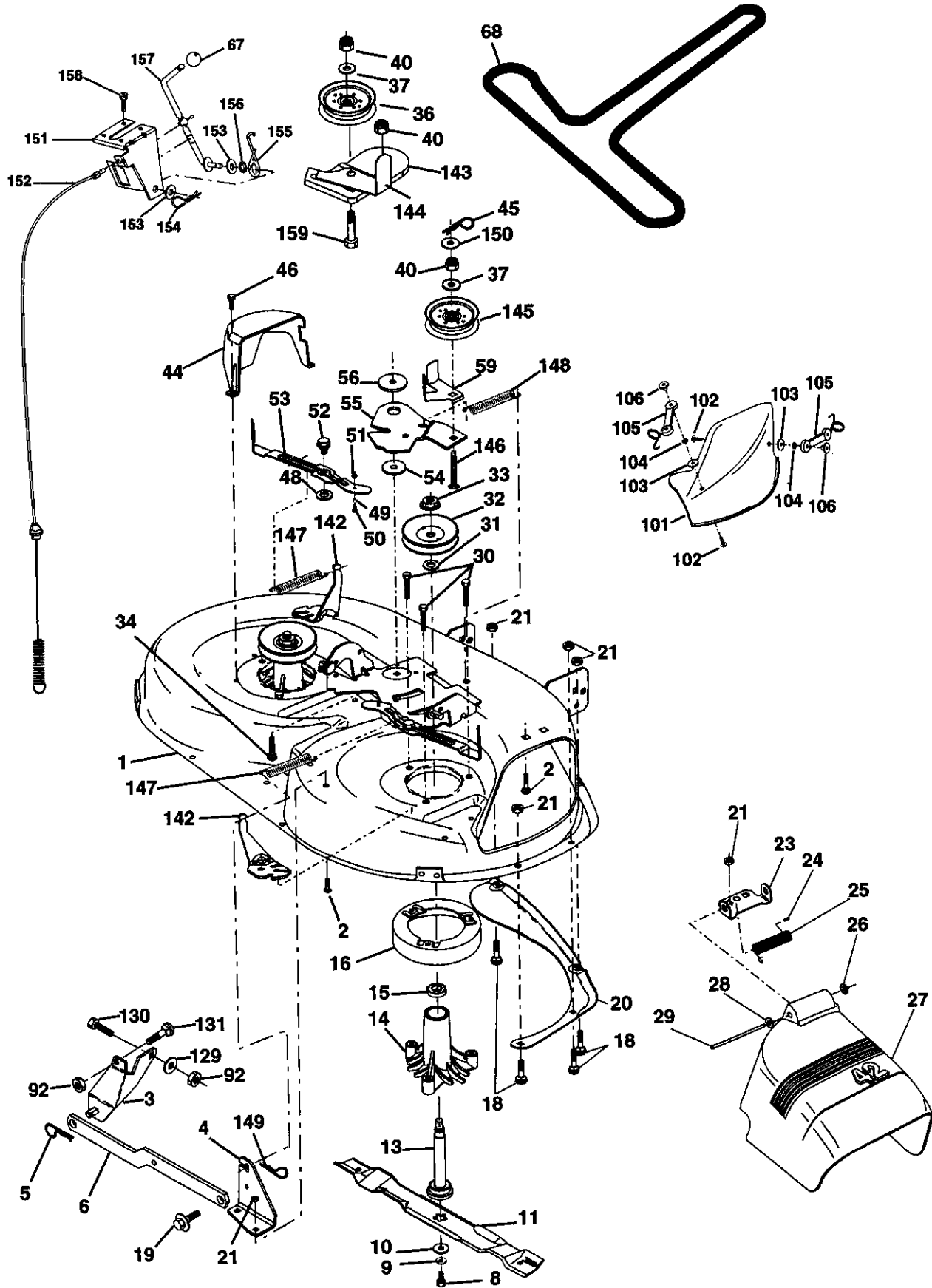

REPAIR PARTS

TRACTOR- -MODEL NO. 917. 277040

MOWER DECK

KEY NO.	PART NO.	DESCRIPTION	KEY NO.	PART NO.	DESCRIPTION
1	165892	Mower Deck Assembly, 42"	54	133943	Washer, Hardened
2	STD533107	Bolt	55	155046	Arm, Idler
3	138017	Bracket Assembly, Sway Bar, Front	56	165723	Spacer, Retainer
4	165460	Bracket Sway Bar 38/42" Deck	59	141043	Guard, TUV Idler
5	STD624008	Retainer Spring	67	149846	Knob Custom Oval
6	178024	Bar Sway Deck	68	180215	V-Belt
8	850857	Bolt, Hex 3/8-24 x 1.25 Gr. 8	92	STD541437	Nut
9	STD551137	Washer, Lock	101	136420	Mulcher Cover
10	140296	Washer, Hardened	102	71081010	Screw
11	134149	Blade, Mulching	103	19061216	Washer #10
13	137645	Shaft Assembly, Mandrel, Vented	104	STD551110	Washer, Lock
14	128774	Housing, Mandrel, Vented	105	160793	Latch Assembly, Bagger
15	110485X	Bearing, Ball, Mandrel	106	2029J	Nut, Weld
16	174493	Stripper, Mower Deck	129	19131312	Washer 13/32 x 13/16 x 12 Ga.
18	72140505	Bolt, Carriage 5/16-18 x 5/8	130	STD523710	Bolt, Fin Hex 3/8-16 UNC x 1 Gr.5
19	132827	Bolt, Shoulder	131	STD533710	Bolt, Rdhd Sqnk 3/8-16UNC x 1
20	159770	Baffle, Vortex	142	165890	Arm Spring Brake Mower
21	STD541431	Nut Crownlock 5/16-18 UNC	143	157109	Bracket Arm Idler 42"
23	177563	Bracket, Deflector	144	158634	Keeper Belt 42" Clutch Cable
24	105304X	Cap, Sleeve	145	165888	Pulley Idler Flat
25	123713X	Spring, Torsion, Deflector	146	171977	Bolt Carriage Idler
26	110452X	Nut, Push	147	131335	Spring Extension
27	130968X428	Shield, Deflector	148	169022	Spring Return Idler
28	19111016	Washer 11/32 x 5/8 x 16 Ga.	149	165898	Retainer Spring Yellow Zinc
29	131491	Rod, Hinge	150	19091216	Washer 9/32 x 3/4 x 16 Ga.
30	173984	Screw Thdrol	151	169670	Bracket Clutch
31	129963	Washer, Spacer	152	181555	Cable Clutch 42 In
32	153535	Pulley, Mandrel	153	169674	Washer Flat 3/8" Type B
33	178342	Nut, Toplock, Flanged	154	169675	Spring Retainer
34	STD533717	Bolt	155	169671	Spring Retention Lever
36	131494	Pulley, Idler, Flat	156	169672	Spacer
37	STD551037	Washer 13/32 x 13/16 x 16 Ga.	157	169669	Rod Clutch
40	STD541437	Nut Crownlock 3/8-16 UNC	158	17720408	Screw Hex Thd Cut 1/4-20 x 1/2
44	140088	Guard, Mandrel, L.H.	159	72140614	Bolt Tdhd Sgn 3/8-16UNC x 1-3/4
45	STD624003	Retainer	--	130794	Mandrel Assembly (Includes Housing, Shaft, and Shaft Hardware Only - Pulley Not Included)
46	137729	Screw, Thd. Roll 1/4-20 x 5/8			
48	133944	Washer, Hardened	--	181268	Replacement Mower, Complete
49	174284	Roller Assembly, Cam Follower			
50	131340	Bolt, Shoulder #10-24 Grade 5			
51	STD541410	Locknut			
52	139888	Bolt, Shoulder 5/16-18 UNC			
53	131845	Arm Assembly, Pad, Brake			

NOTE: All component dimensions given in U.S.inches
1 inch = 25.4 mm

REPAIR PARTS

TRACTOR- -MODEL NO. 917. 277040

TRANSAXLE - - MODEL NUMBER 322-0510

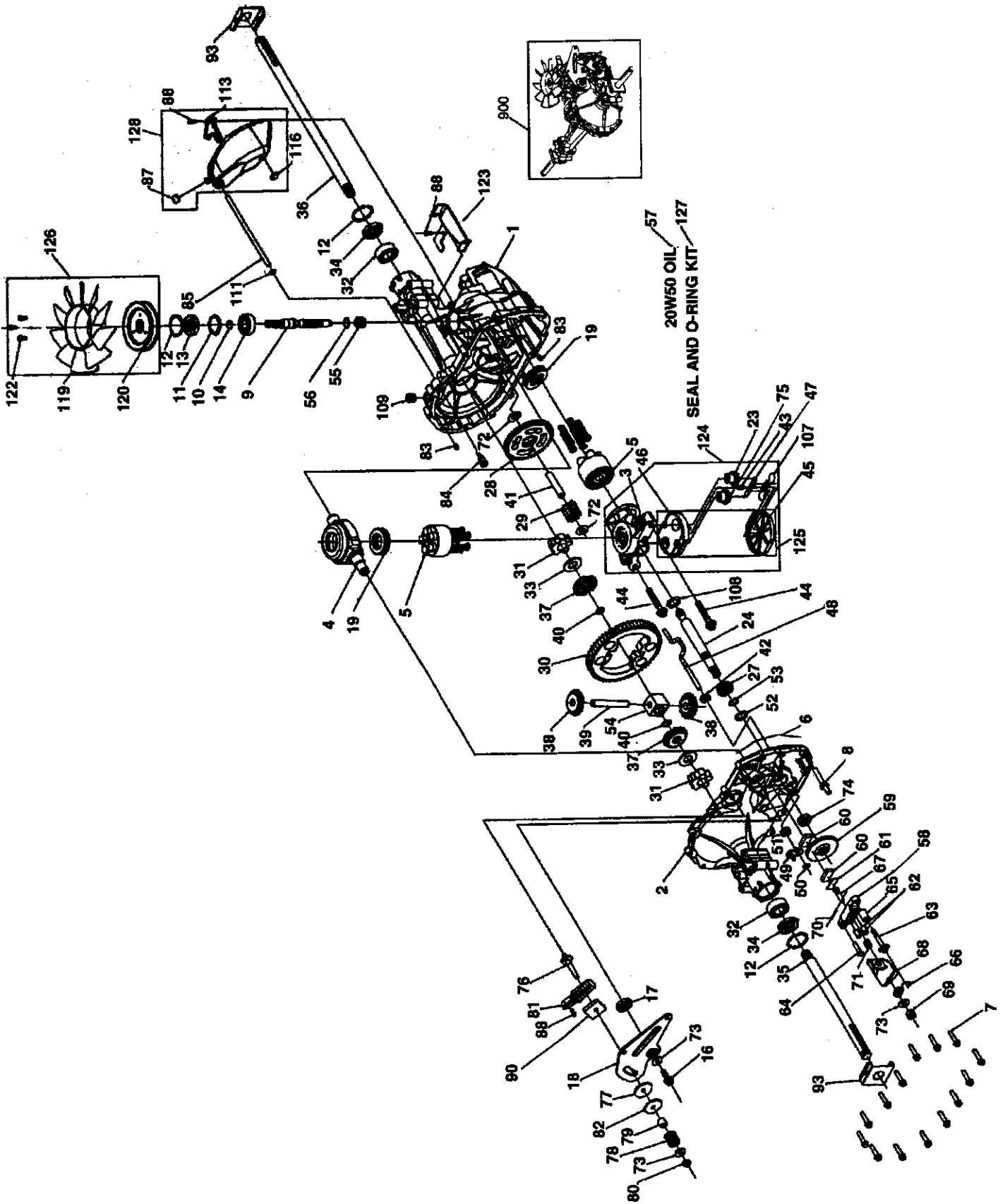

REPAIR PARTS

TRACTOR- -MODEL NO. 917. 277040

TRANSAXLE - - MODEL NUMBER 322-0510

KEY NO.	PART NO.	DESCRIPTION	KEY NO.	PART NO.	DESCRIPTION
1	170351	Main Housing, Assembly	60	142883	Brake Puck
2	170352	Side Housing, Assembly	61	142882	Puck Plate
3	170353	Center Section, Assembly	62	142887	Brake Actuating Pin
4	170354	Swashplate, Trunion Machined	63	170410	HFHCS 1/4-20X2 W/Patch, Special Flange
5	169898	Block - Assembly	64	142892	Bolt, 1/4-20 X 1 W/Patch
6	170355	Sealant	65	170411	Spacer
7	170356	Hex Flange Screw 1/4-20 X 1.25	66	170412	Spring, Brake Arm Bias
8	170357	Stud, 5/16-24 Hex Double End	67	170413	SQ. HD. BOLT 5/16-24-Ribbed
9	170358	Shaft, Input	68	170414	Arm, Brake
10	170359	Ring - Retaining	69	170415	Slotted Hex Nut 5/16-24
11	170360	Spacer	70	170416	Cotter Pin 3/32 X 3/4
12	169870	Ring - Retaining	71	170417	Compression Spring Brake Anti-Drag
13	170361	Seal, Lip .67 X 1.58 X .276	72	170418	Washer, HT .5 I.D. X 1 O.D. X .032
14	173158	Ball Brg 17MM ID X 40MM OD X 12MM	73	142884	Flat - Washer 11/32 I.D. X 7/8 O.D.
16	170362	Hex FLange Head Screw 5/16-24 X 0.75	74	170419	Oil Seal .625 X 1.0 X .25
17	170363	Lip Seal 18 X 32 X 7	75	170420	Check Plug Assembly, .027, Washer
18	170364	Arm, Control	76	170421	Stud, 5/16-24 Friction Pack
19	173159	Bearing, 30X52X13 Thrust	77	170422	Puck, .330 X 1.50 X .0975
23	170365	Check Plug Assembly, Washer	78	142969	Spring, Helical Comp
24	170366	Shaft, Motor1	79	142980	Spacer
27	170367	Gear - Pinion, 13T	80	150778	Hex Lock Nut 5/16-24 UNJF(Nylon Insert)
28	170368	10T/48T GEAR	81	170423	Wedge, Friction Pack
29	170369	Gear, 10T Jackshaft	82	170424	Clip, Washer .316X1.50X.1046 (Plated)
30	170370	60T Bull Gear	83	161168	Pin, Standard Headless
31	170371	Sleeve Bearing .75 X 1.575 X .625	84	170425	Fitting, 5/16 Sae 5/32 Tube
32	170389	Sleeve Bearing (Outboard).75X1.750X.625	85	170426	Hose, Expansion Tank
33	142991	Washer, 3/4 ID X 1-1/2 OD X .13 THK	87	173160	Cap, Vent
34	170390	Lip Seal Axle Seal	88	170429	Bolt, Self Tapping 10-32 X 1/2
35	170391	Shaft, Axle .75 X 11.39 (Key, R.H.)	90	170430	Puck, Inner Wedge
36	170392	Shaft, Axle .75 X 16.99 (Key, L.H.)	93	170431	Spring Clip - Housing Thrust
37	150792	Miter Gear (SPLINED)	107	170432	Deflector
38	150793	Miter Gear 15T (0.5 ID)	108	170433	Washer, Motorshaft .71ID X 1.15OD X .030THK
39	150809	Shaft	109	170434	Plug, Sae #6
40	170393	Ring, Spiral Retaining	111	170435	O-ring .07 x .301 I.D.
41	170394	Pin, Jackshaft	113	170437	Bracket, Support Expansion Tank
42	170395	Magnet, Rling	116	170438	Silicon Sponge
43	170396	Spring, Bypass	119	173161	Fan
44	150797	Hydro mtg Screw 3/8-24 X 2.5 Long	120	170440	Pulley
45	170397	Filter	122	173162	#12 T.F. Screw-Indented Hex Washer Head
46	170398	Base, Filter	123	173163	Bracket Belt Keeper
47	170399	Actuator, Bypass	124	170444	Center Section-Filter-Bypass Assembly
48	170400	Rod, Bypass Actuator	125	170445	Filter Assembly
49	170401	Arm, Bypass	126	173164	Fan - Pulley Service Assembly
50	170402	Retaining Ring .250 External	127	170447	Seal - O-ring Kit
51	170403	Seal, Lip .741 X .250 X .250 TC	128	173165	Kit, Expansion Tank
52	170404	Flat Washer, 5/8 ID X 1.0 OD X .05 THK	900	171613	Transaxle, complete
53	170405	Retaining Ring			
54	170406	Bearing, Center Block			
55	142977	Spring - Helical Compression			
56	142978	Washer			
57	150798	20W-50 OIL 72.8 oz			
58	170407	Brake Yoke			
59	170408	Rotor, Brake			

NOTE: All component dimensions given in U.S. inches
1 inch = 25.4 mm

REPAIR PARTS

TRACTOR- -MODEL NO. 917. 277040

BRIGGS & STRATTON ENGINE-MODEL NUMBER 310707, TYPE NUMBER 0203-E1

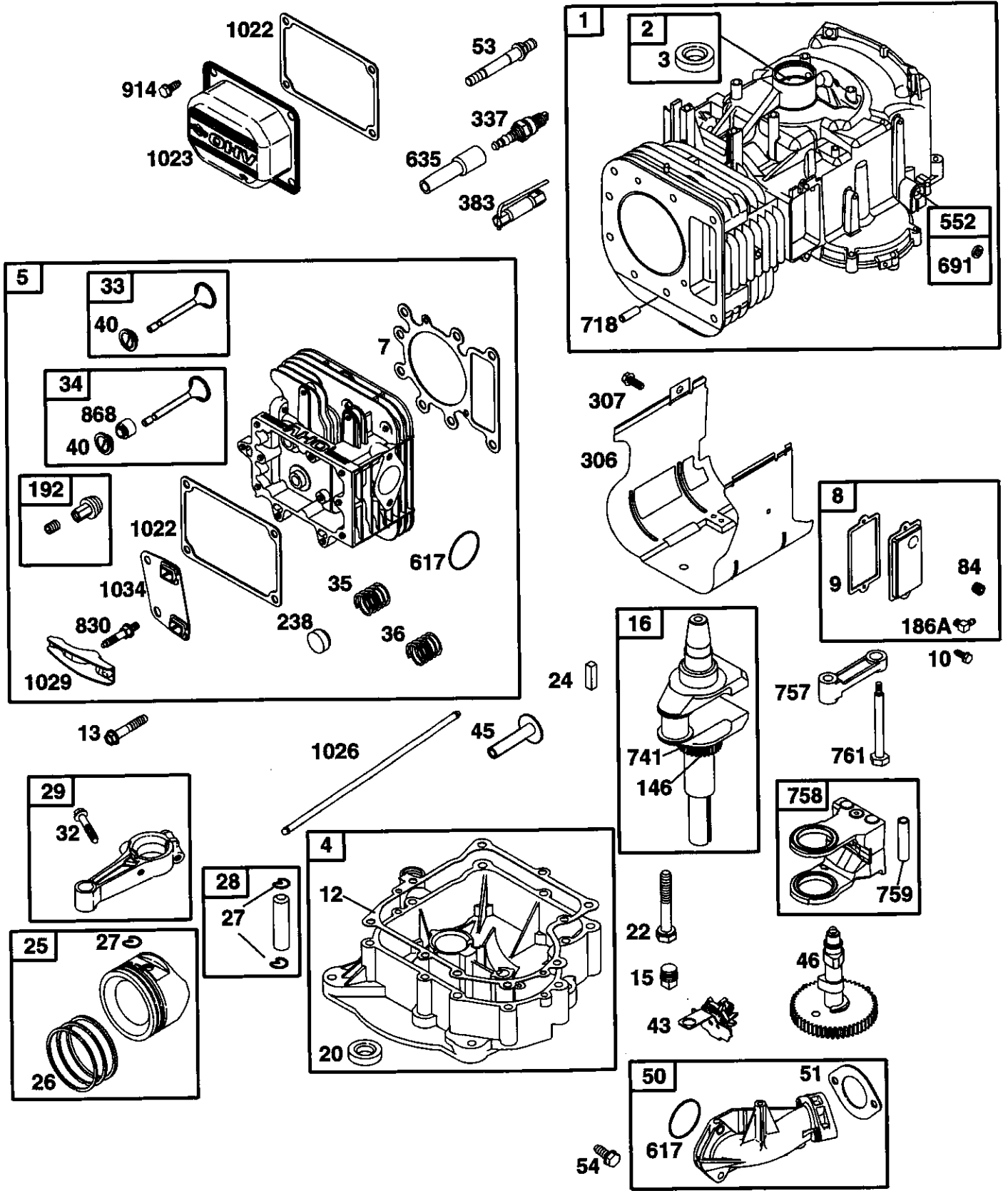

310707-0203-E1

REPAIR PARTS

TRACTOR- -MODEL NO. 917. 277040

BRIGGS & STRATTON ENGINE-MODEL NUMBER 310707, TYPE NUMBER 0203-E1

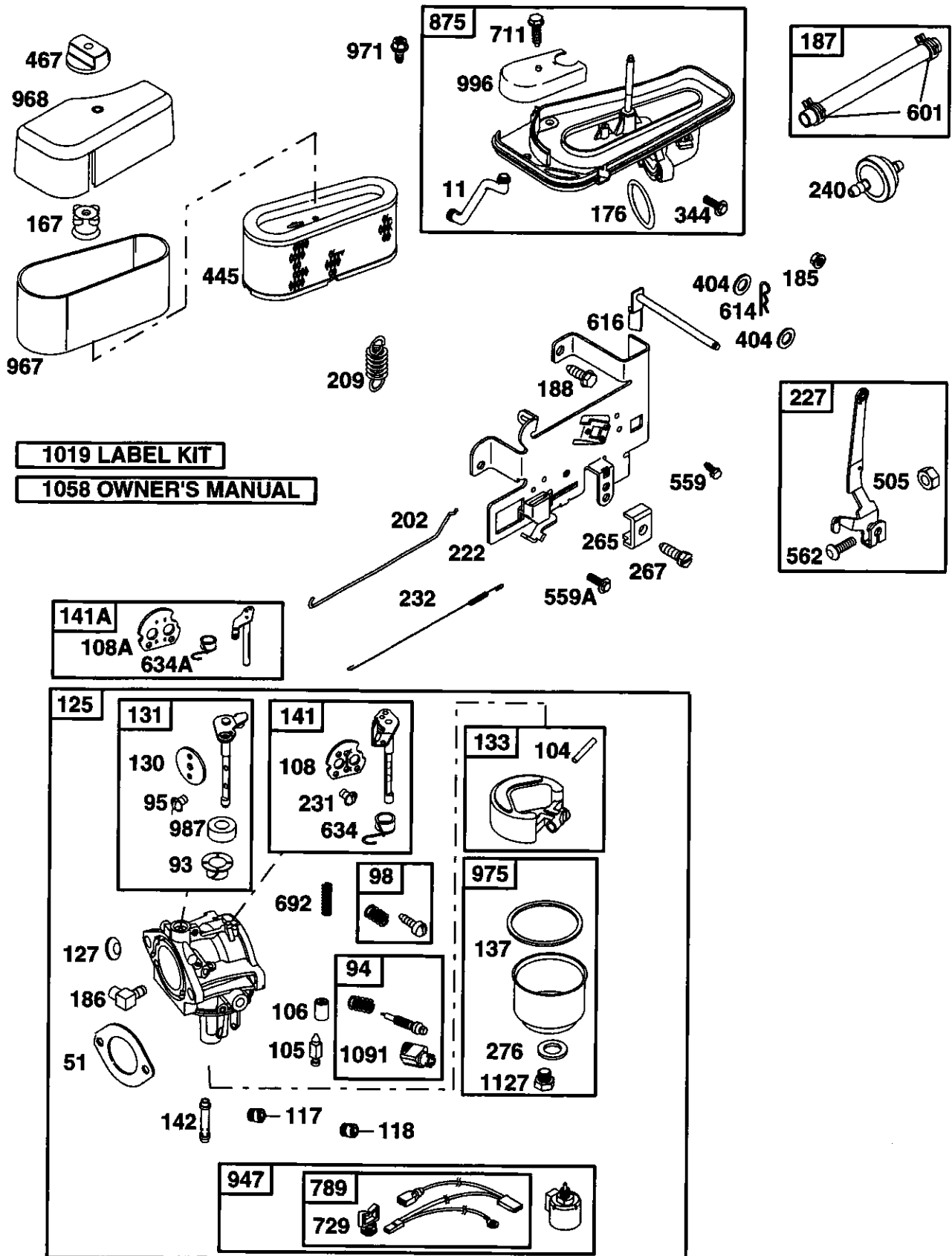

310707-0203-E1

REPAIR PARTS

TRACTOR- -MODEL NO. 917. 277040

BRIGGS & STRATTON ENGINE-MODEL NUMBER 310707, TYPE NUMBER 0203-E1

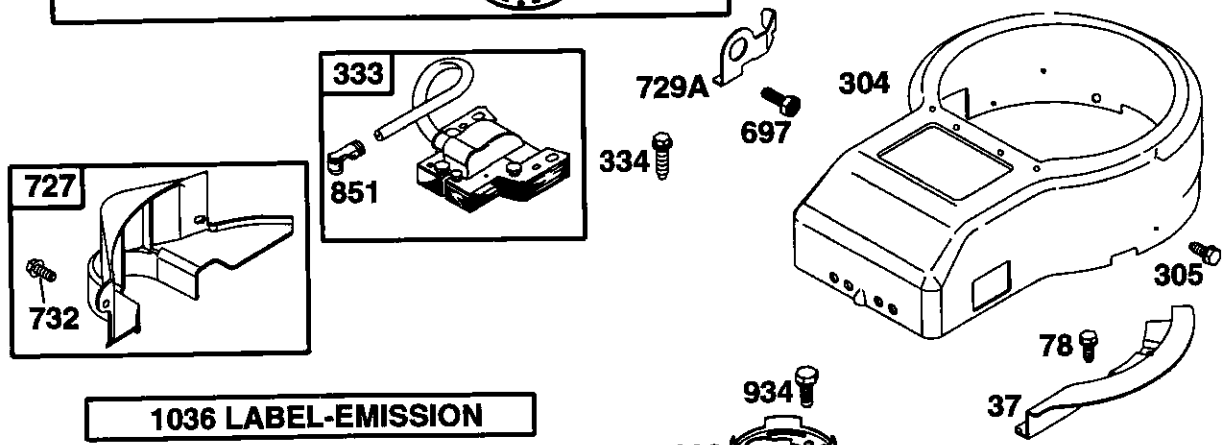
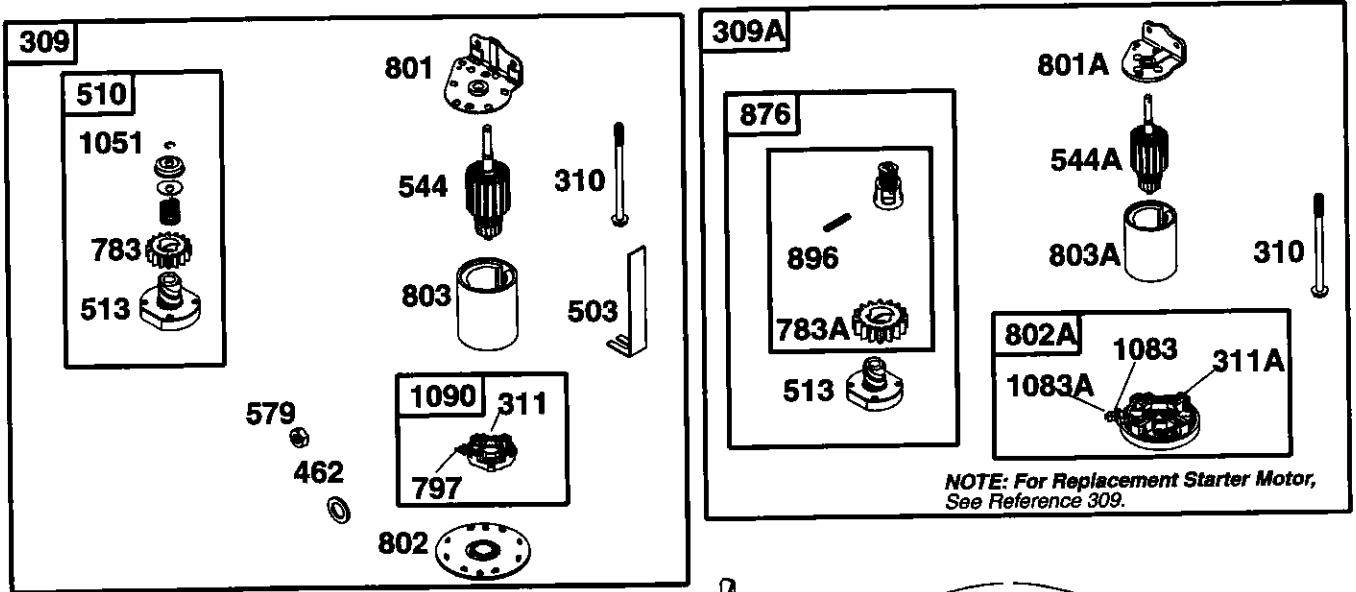

1036 LABEL-EMISSION

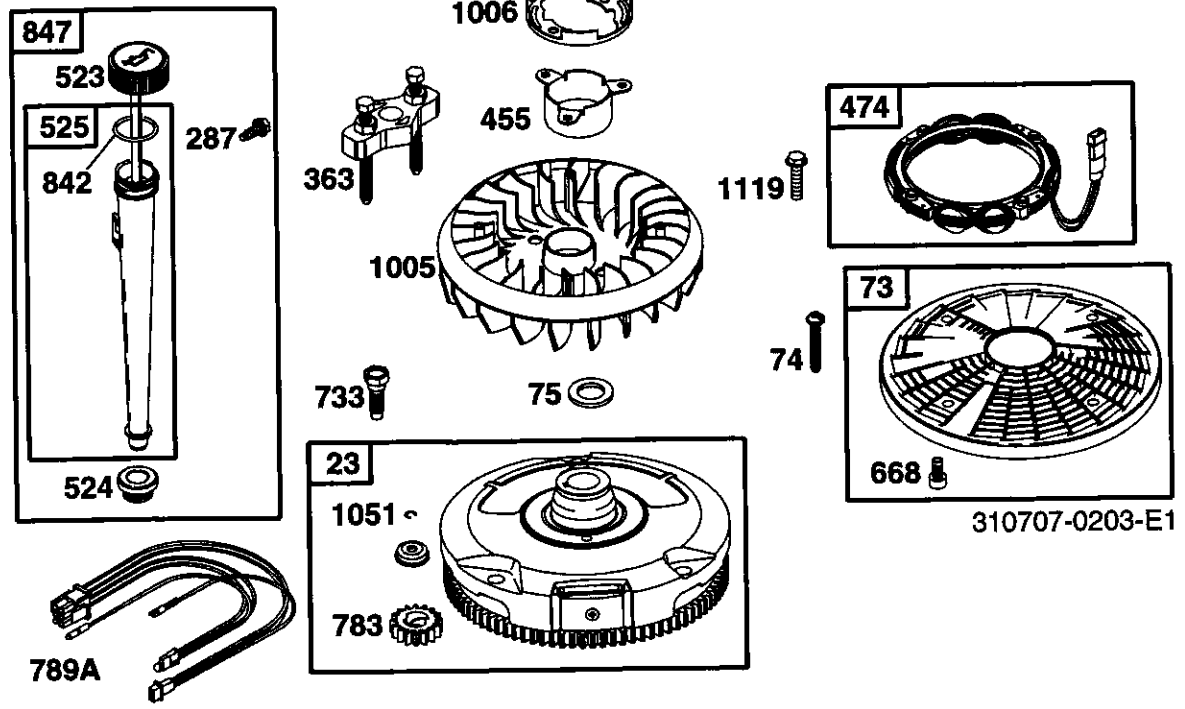

REPAIR PARTS

TRACTOR- -MODEL NO. 917. 277040

BRIGGS & STRATTON ENGINE-MODEL NUMBER 310707, TYPE NUMBER 0203-E1

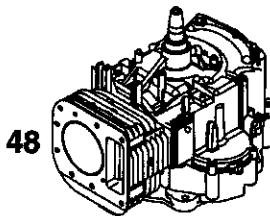
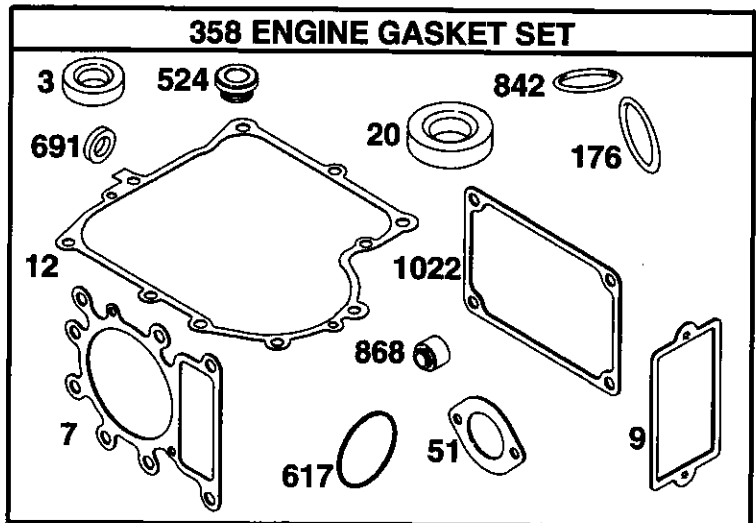
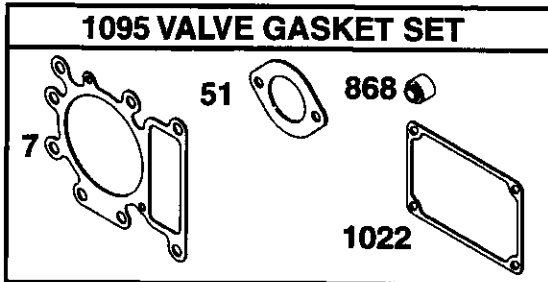
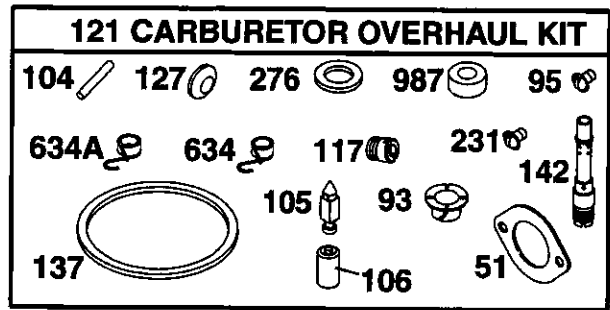
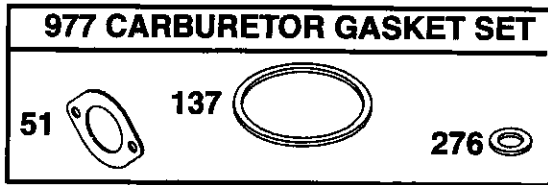

NIKKI

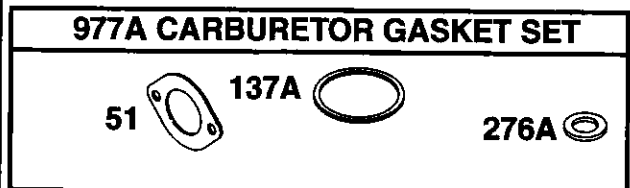
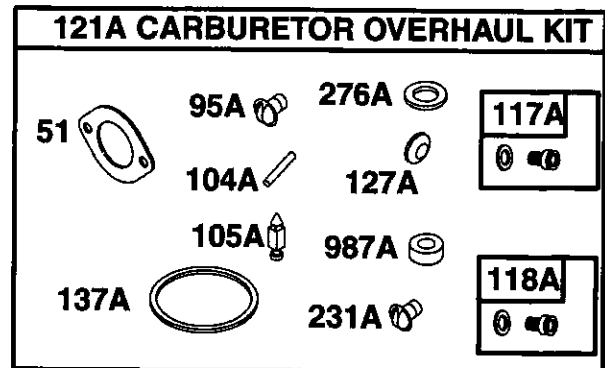
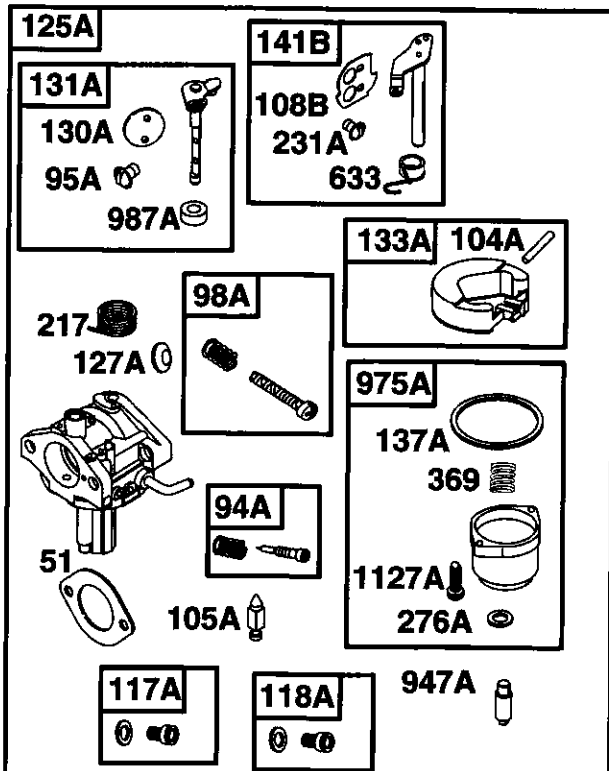

310707-0203-E1

REPAIR PARTS

TRACTOR- -MODEL NO. 917. 277040

BRIGGS & STRATTON ENGINE-MODEL NUMBER 310707, TYPE NUMBER 0203-E1

KEY NO.	PART NO.	DESCRIPTION	KEY NO.	PART NO.	DESCRIPTION
1	690156	Cylinder Assembly	105A	694922	∅ Valve-Float Needle
2	399265	Kit-Bushing/Seal (Magneto Side)	106	690577	∅ Seat-Inlet
3	391086	• Seal-Oil (Magneto Side)	108	690464	Valve-Choke (Manual Choke)
4	494238	Sump-Engine	108A	692344	Valve-Choke(Choke-A-Matic)
5	690188	Head-Cylinder	108B	695419	Valve-Choke(Nikki Carburetor)
7	692410	+ Gasket-Cylinder Head	117	692408	∅ Jet-Main (Standard)
8	696126	Breather Assembly	117A	695415	∅ Jet-Main (Standard)
9	27803	• Gasket-Breather	118	692411	Jet-Main (High Altitude)
10	691666	Screw (Breather Assembly)	118A	695416	∅ Jet-Main (High Altitude)
11	691328	Tube-Breather	121	690191	Kit-Carburetor Overhaul
12	692226	• Gasket-Crankcase (.015" Thick, Standard)	121A	695427	Kit-Carburetor Overhaul
	692406	• Gasket-Crankcase (.005" Thick)	125	690194	Carburetor
	692405	• Gasket-Crankcase (.009" Thick)	125A	---	Carburetor (Nikki) (Service with Walbro Carburetor)
13	690360	Screw (Cylinder Head)	127	695005	∅ Plug-Welch
15	690946	Plug-Oil Drain	127A	690727	∅ Plug-Welch
16	690136	Crankshaft	130	691750	Valve-Throttle
20	291675	• Seal-Oil (PTO Side)	130A	695418	Valve-Throttle
22	692125	Screw (Crankcase Cover)	131	494379	Kit-Throttle Shaft
23	693557	Flywheel	131A	695421	Kit-Throttle Shaft
24	222698	Key-Flywheel	133	494381	Float-Carburetor
25	692271	Piston Assembly (Standard)	133A	694914	Float-Carburetor
	692272	Piston Assembly (.010" Oversize)	137	281165	∅‡ Gasket-Float Bowl
	692273	Piston Assembly (.020" Oversize)	137A	695426	∅‡ Gasket-Float Bowl
	692274	Piston Assembly (.030" Oversize)	141	495097	Kit-Choke Shaft (Manual Choke)
26	690162	Ring Set-Piston (Standard)	141A	495931	Kit-Choke Shaft (Choke-A-Matic)
	692164	Ring Set-Piston (.010" Oversize)	141B	695420	Kit-Choke Shaft (Nikki)
	692166	Ring Set-Piston (.020" Oversize)	142	692412	∅ Nozzle-Carburetor
	692168	Ring Set-Piston (.030" Oversize)	146	691639	Key-Timing
27	691299	Lock-Piston Pin	167	692297	Air Cleaner Stud Seal
28	498319	Pin-Piston (Standard)	176	691917	• O-Ring Seal (Air Cleaner)
	498320	Pin-Piston (.020" Oversize)	185	690958	Nut (Air Cleaner Base)
29	692419	Rod-Connecting (Standard)	186	692317	Connector-Hose
	499940	Rod-Connecting (.020" Undersize)	186A	691609	Connector-Hose
32	692852	Screw (Connecting Rod)	187	691050	Line-Fuel (Cut to Required Length)
33	495856	Valve-Exhaust	188	691693	Screw (Control Bracket)
34	495857	Valve-Intake	192	691986	Adjuster-Rocker Arm
35	691279	Spring-Valve (Intake)	202	691841	Link-Mechanical Governor
36	691279	Spring-Valve (Exhaust)	209	692208	Spring-Governor
37	690456	Guard-Flywheel	217	695409	Spring-Choke Return
40	691752	Retainer-Valve	222	694042	Bracket-Control
43	691968	Slinger-Governor/Oil	227	691374	Control Lever-Governor
45	690564	Tappet-Valve	231	691636	∅ Screw (Choke Valve)
46	692421	Camshaft	231A	690718	∅ Screw (Choke Valve)
48	692706	Short Block (311707-0028-E1 Replacement Engine)	232	691842	Spring-Governor Link
50	690193	Manifold-Intake	238	691843	Cap-Valve
51	692137* ∅‡+	Gasket-Intake	240	394358	Filter-Fuel
53	690227	Stud (Carburetor)	265	691024	Clamp-Casing
54	691148	Screw (Intake Manifold)	267	695134	Screw (Casing Clamp)
73	690492	Screen-Rotating	276	692255	∅‡ Sealing Washer
74	691674	Screw (Rotating Screen)	276A	695410	∅‡ Sealing Washer
75	690582	Washer (Flywheel)	287	691002	Screw (Dipstick Tube)
78	690661	Screw (Flywheel Guard)	304	690844	Housing-Blower
84	690343	Plug-Breather			
93	690602	∅ Bushing-Throttle Shaft			
94	498030	Kit-Idle Mixture			
94A	695425	Kit-Idle Mixture			
95	691636	∅ Screw (Throttle Valve)			
95A	690718	∅ Screw (Throttle Valve)			
98	495800	Kit-Idle Speed			
98A	695408	Kit-Idle Speed			
104	690525	∅ Pin-Float Hinge			
104A	694918	∅ Pin-Float Hinge			
105	231855	∅ Valve-Float Needle			

RPM Settings: Low Speed: 1900-2100
High Speed: 3000-3200

- Included in Engine Gasket Set, Key. No. 358
- ∅ Included in Carburetor Overhaul Kit, Key. No. 121 and 121A
- ‡ Included in Carburetor Gasket Set, Key. No. 977 and 977A
- + Included in Valve Gasket Set, Key. No. 1095

NOTE: All component dimensions given in U.S. inches
1 inch = 25.4 mm

REPAIR PARTS

TRACTOR- -MODEL NO. 917. 277040

BRIGGS & STRATTON ENGINE-MODEL NUMBER 310707, TYPE NUMBER 0203-E1

KEY NO.	PART NO.	DESCRIPTION	KEY NO.	PART NO.	DESCRIPTION
305	690960	Screw (Blower Housing)	789	692037	Harness-Wiring
306	690499	Shield-Cylinder	789A	695050	Harness-Wiring
307	691003	Screw (Cylinder Shield)	797	693167	Nut (Brush Retainer)
309	693551	Motor-Starter	801	691283	Cap-Drive
309A	— — —	Motor-Starter (For Replacement Starter Motor, See Reference 309)	801A	394856	Cap-Drive
310	690323	Screw (Starter Motor)	802	691286	Cap-End
311	497608	Brush Set	802A	395537	Cap-End
311A	395538	Brush Set	803	693757	Housing-Starter
333	495859	Armature-Magneto	803A	398159	Housing-Starter
334	691061	Screw (Armature Magneto)	830	691095	Stud (Rocker Arm)
337	691043	Spark Plug	842	691870	• Seal-O Ring (Dipstick Tube)
344	693675	Screw (Cable Clamp)	847	496415	Dipstick/Tube Assembly
358	690189	Engine Gasket Set	851	692424	Terminal-Spark Plug
363	19203	Flywheel Puller	868	690968	*+ Seal-Valve
369	695422	Spring-Float Bowl	875	696129	Base-Air Cleaner
383	89838	Wrench-Spark Plug	876	495877	Kit-Pinion Spring
404	691691	Washer (Governor Crank)	896	691641	Pin-Drive Retainer
445	496894	Filter-Air Cleaner Cartridge	914	690960	Screw (Rocker Cover)
455	691173	Cup-Flywheel	934	691058	Screw (Fan Retainer)
462	691261	Washer (Brush Retainer)	947	497672	Solenoid-Fuel
467	691668	Knob-Air Cleaner	947A	695423	Solenoid-Fuel
474	696459	Alternator	967	272043	Filter-Pre Cleaner
503	691532	Strap-Starter	968	691916	Cover-Air Cleaner
505	691251	Nut (Governor Control Lever)	971	692126	Screw (Air Cleaner Base)
510	693699	Drive-Starter	975	495933	Bowl-Float
513	692024	Clutch-Drive	975A	695417	Bowl-Float
523	692014	Dipstick	977	690192	Set-Carburetor Gasket
524	281370	• Seal-Dipstick Tube	977A	695428	Set-Carburetor Gasket
525	691398	Tube-Dipstick	987	691326Ø •	Seal-Throttle Shaft
544	692034	Armature-Starter	987A	690998	Seal-Throttle Shaft
544A	390837	Starter-Armature	996	690678	Carburetor Shield
552	491986	Bushing-Governor Lever	1005	695056	Fan-Flywheel
562	691119	Bolt (Governor Control Lever)	1006	690452	Retainer-Fan
559	697561	Screw (Remote Choke Stop)	1019	690180	Kit-Label
559A	693675	Screw (Remote Choke Stop)	1022	272475	*+ Gasket-Rocker Cover
579	691029	Nut (Starter Cable)	1023	691192	Cover-Rocker
601	95162	Clamp-Hose	1026	692003	Rod-Push (Intake)
614	691620	Pin-Cotter	— —	692011	Rod-Push (Exhaust)
616	692012	Crank-Governor	1029	691751	Arm-Rocker
617	692138	• O-Ring Seal (Intake Manifold)	1034	690822	Guide-Push Rod
633	695414	Seal-Choke/Throttle Shaft	1036	695700	Label-Emission
634	690801	Ø Seal-Spring Assembly (Manual Choke)	1051	691265	Retainer-Brush
634A	690802	Ø Seal-Spring Assembly (Choke-A-Matic)	1058	275038	Owner's Manual
635	691909	Boot-Spark Plug	1083	691626	Nut (Starter Terminal)
668	691323	Spacer	1083A	690958	Nut (Starter Terminal)
691	692407	• Seal-Governor Shaft	1090	691293	Retainer-Brush
692	690572	Spring-Detent	1091	691333	Cap-Limiter
697	690372	Screw (Drive Cap)	1095	690190	Valve Gasket Set
711	690703	Screw (Carburetor Shield)	1119	691183	Screw (Alternator)
718	690959	Pin-Locating	1127	691657	Screw (Float Bowl)
727	490324	Cover-Starter Drive	1127A	695407	Screw (Float Bowl)
729	691335	Clip-Wire			
729A	691224	Clip-Wire			
732	691002	Screw (Starter Drive Cover)			
733	691658	Screw (Crankshaft Extension)			
741	691284	Gear-Timing			
757	691714	Link-Counterweight			
758	692423	Counterweight			
759	691239	Pin-Counterweight			
761	691096	Screw (Counterweight)			
783	693713	Gear-Pinion			
783A	693059	Gear-Pinion			

RPM Settings: Low Speed: 1900-2100
High Speed: 3000-3200

- Included in Engine Gasket Set, Key. No. 358
- Ø Included in Carburetor Overhaul Kit, Key. No. 121 and 121A
- ‡ Included in Carburetor Gasket Set, Key. No. 977 and 977A
- + Included in Valve Gasket Set, Key. No. 1095

NOTE: All component dimensions given in U.S. inches
1 inch = 25.4 mm

LIMITED TWO YEAR WARRANTY ON CRAFTSMAN RIDING EQUIPMENT

For two (2) years from the date of purchase, if this Craftsman Riding Equipment is maintained, lubricated and tuned up according to the instructions in the owner's manual, Sears will repair or replace, free of charge, any parts found to be defective in material or workmanship.

This Warranty does not cover:

- Expendable items which become worn during normal use, such as blades, spark plugs, air cleaners, belts, etc.
- Tire replacement or repair caused by punctures from outside objects, such as nails, thorns, stumps, or glass.
- Repairs necessary because of operator abuse, negligence, improper storage or accident or the failure to maintain the equipment according to the instructions contained in the owner's manual.
- Riding equipment used for commercial or rental purposes.

LIMITED 90 DAY WARRANTY ON BATTERY

For ninety (90) days from date of purchase, if any battery included with this riding equipment proves defective in material or workmanship and our testing determines the battery will not hold a charge, Sears will replace the battery at no charge.

IN-HOME WARRANTY SERVICE ON YOUR CRAFTSMAN RIDING EQUIPMENT IS AVAILABLE AT NO-CHARGE FOR 30 DAYS FROM THE DATE OF PURCHASE. PLEASE CONTACT YOUR NEAREST SERVICE CENTER. AFTER 30 DAYS FROM THE DATE OF PURCHASE, WARRANTY SERVICE IS AVAILABLE BY TAKING YOUR CRAFTSMAN RIDING EQUIPMENT TO YOUR NEAREST SEARS SERVICE CENTER. (IN-HOME WARRANTY SERVICE WILL STILL BE AVAILABLE AFTER 30 DAYS FROM THE DATE OF PURCHASE BUT A STANDARD TRIP CHARGE WILL APPLY.) THIS WARRANTY APPLIES ONLY WHILE THIS PRODUCT IS IN THE UNITED STATES.

This Warranty gives you specific legal rights, and you may also have other rights which may vary from state to state.

SEARS, ROEBUCK AND CO., D/817 WA, HOFFMAN ESTATES, IL 60179

CRAFTSMAN®