

REPAIR PARTS MANUAL
MODEL NO. 277080
Lawn Tractor

25HK 48" HD

2002

CRAFTSMAN®

HOW TO USE THIS MANUAL

This manual is designed to provide the customer with a means to identify the parts on his/her tractor when ordering repair parts. The illustrations may or may not represent the actual assemblies; therefore, it is not recommended to use this manual as a guide to assemble or disassemble the tractor. Some hardware and parts are drawn larger in order to more readily identify them.

Each tractor has its own model number.

The model number for your tractor can be found on the fender under the seat.

When ordering parts, always give the following information:

- Product - "Tractor"
- Model Number - "277080"
- Part Number
- Part Description

TABLE OF CONTENTS

SCHEMATIC.....	3
ELECTRICAL.....	4-5
CHASSIS.....	6-7
DRIVE.....	8-9
STEERING.....	10-11
ENGINE.....	12-13
SEAT.....	14
DECALS.....	15
MOWER LIFT.....	16-17
MOWER DECK.....	18-19
TRANSAXLE.....	20-21
ENGINE BREAKDOWN.....	22-26
WARRANTY.....	28

TRACTOR- -MODEL NO. 917. 277080

SCHEMATIC

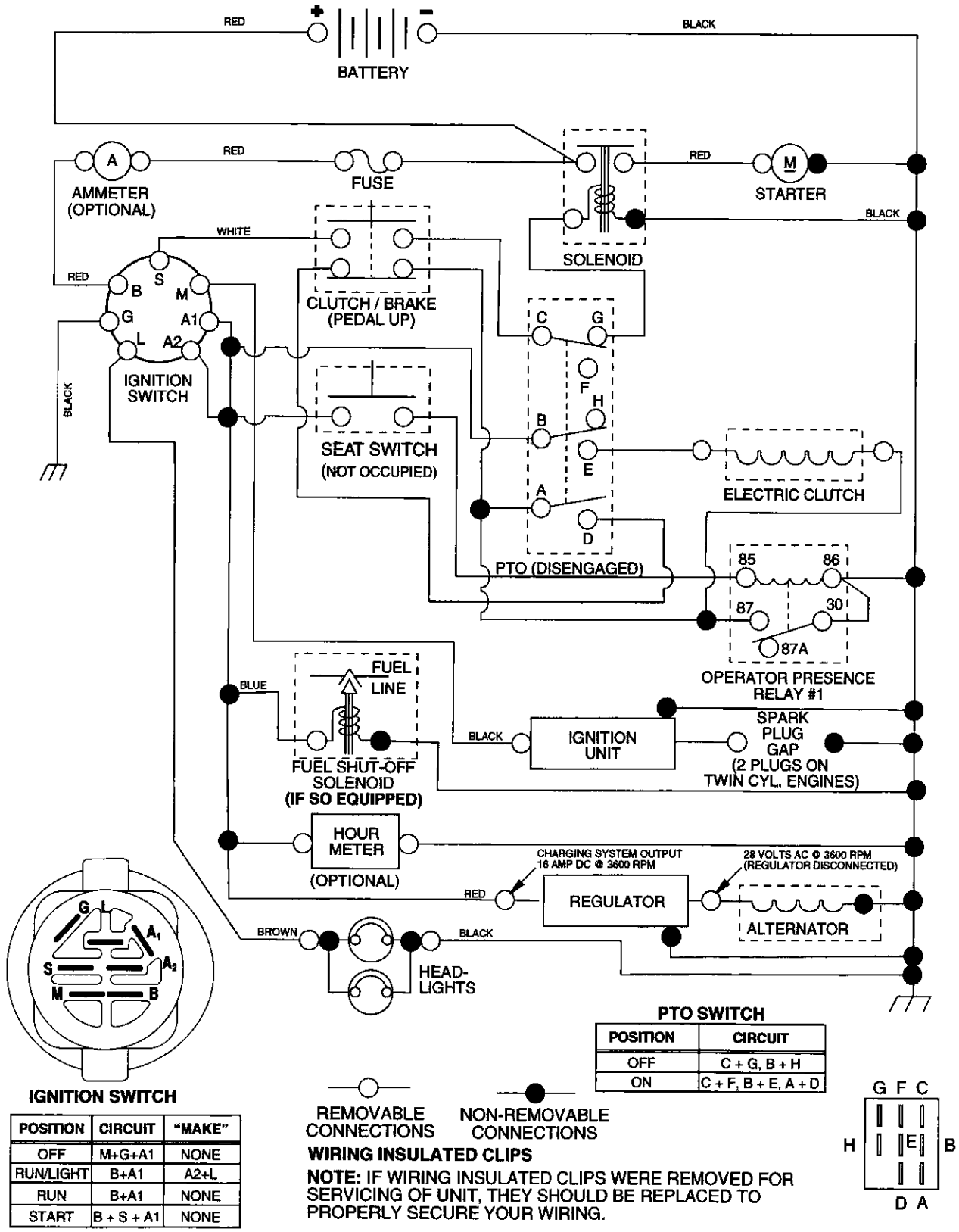

REPAIR PARTS

TRACTOR- -MODEL NO. 917. 277080

ELECTRICAL

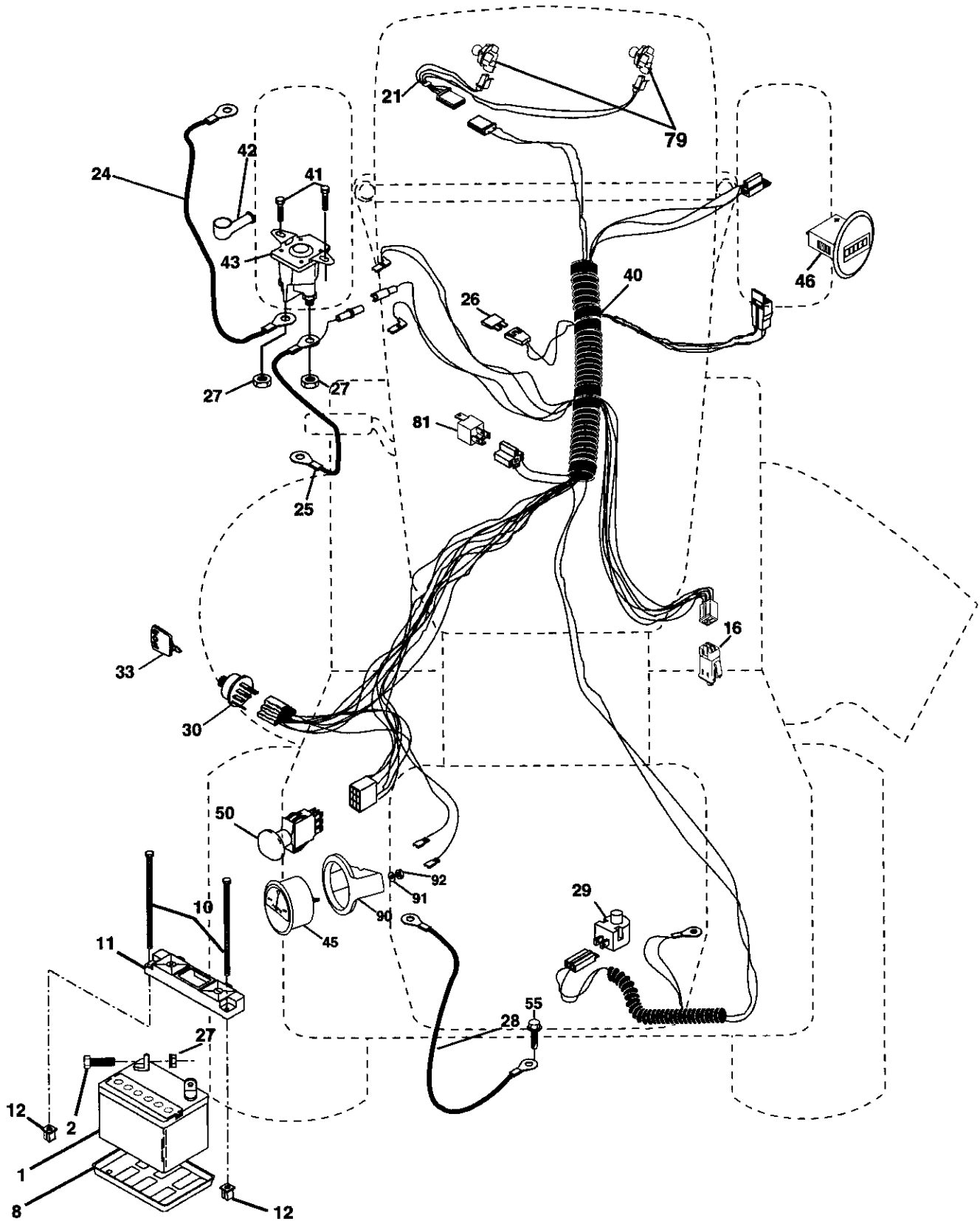

REPAIR PARTS

TRACTOR- MODEL NO. 917. 277080

ELECTRICAL

KEY NO.	PART NO.	DESCRIPTION
1	163465	Battery
2	74760412	Bolt, Hex 1/4-20 x 3/4
8	7603J	Tray, Battery
10	145211	Bolt, Btr Front 1/4-20 x 7-1/2
11	150109	Holddown Battery Front Mount
12	145769	Nut, Push Nylon Battery Front 1/4
16	176138	Switch Interlock Push-In
21	175449	Harness, Light
24	4799J	Cable, Battery
25	146148	Cable, Battery
26	175158	Fuse
27	73510400	Nut Keps Hex 1/4-20 UNC
28	145491	Cable, Ground
29	160784	Switch, Seat
30	175442	Switch, Ignition
33	175447	Key
40	179737	Harness, Ignition
41	71110408	Bolt Fin Hex 1/4-20 Unc x 1/2
42	131563	Cover, Terminal
43	178861	Solenoid
45	177500	Ammeter
46	177501	Hourmeter
50	178461	Switch Pto
55	17490508	Screw Thdrol 5/16-18 x 1/2
79	175448	Lamp and Holder Asm
81	109748X	Relay Asm

NOTE: All component dimensions given in U.S. inches 1 inch = 25.4 mm

REPAIR PARTS

TRACTOR- -MODEL NO. 917. 277080

CHASSIS AND ENCLOSURES

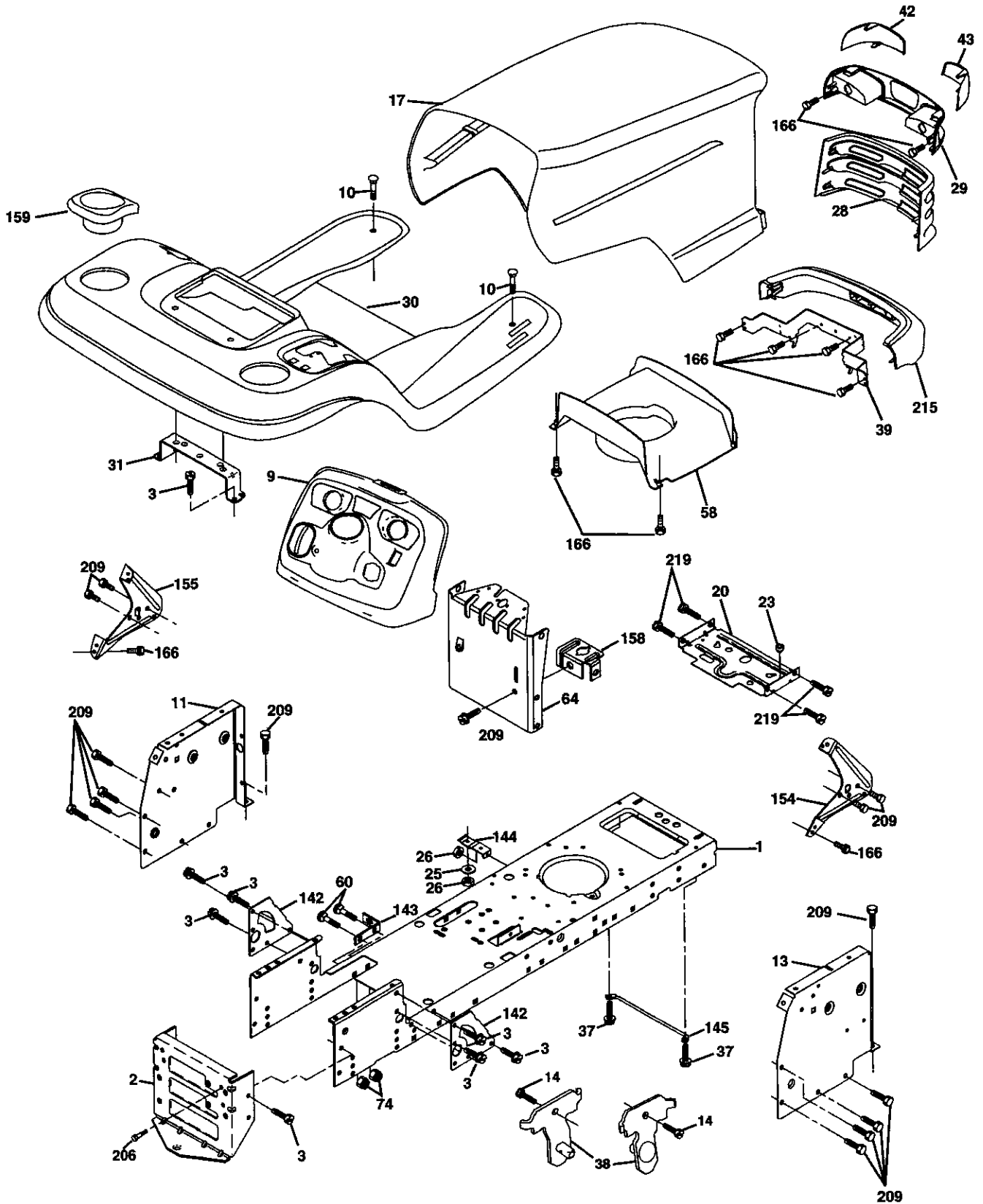

REPAIR PARTS

TRACTOR- -MODEL NO. 917. 277080

CHASSIS AND ENCLOSURES

KEY NO.	PART NO.	DESCRIPTION
1	174619	Chassis
2	176554	Drawbar
3	17060612	Screw, 3/8-16 x 3/4
9	172542X418	Dash
10	72140608	Bolt RDHD 3/8-16 UNC x 1
11	174996	Panel, Dash, LH
13	179174X010	Panel, Dash, RH
14	17490608	Screw Thdrol 3/8-16 x 1/2
17	172540X615	Hood Assembly
20	180679	Plate Battery
23	124028X	Bushing Snap
25	19131312	Washer 13/32 x 13/16 x 12 Gauge
26	STD541437	Locknut, Hex, with Insert 3/8-16 UNC
28	174945X418	Grille
29	174944X418	Lightbox Dual
30	175692X615	Fender/Footrest
31	139976	Bracket, Fender/Support
37	17490508	Screw, Thdrol. 5/16-18 x 1/2 TYT
38	175710	Bracket Asm Pivot Mower Rear
39	174988	Bracket Pivot Hood
42	172545X599	Lens Lh
43	172544X599	Lens Rh
58	174993	Duct Hood
60	STD533707	Bolt Rdhd Sqnk 3/8-16 UNC x 3/4
64	174997	Dash Lower
74	STD541437	Nut Crownlock 3/8-16 UNC
142	175702	Plate Reinforcement
143	154966	Bracket Swaybar Chassis
144	175582	Bracket Footrest
145	156524	Rod Pivot Chassis/Hood
154	174679	Bracket Dash Rh
155	174680	Bracket Dash Lh
158	162037	Parking Brake Bkrt
159	155123X418	Cupholder Stl Bk
166	164863	HWDH:-Lo. #13-16 x 3/4
206	170165	Bolt Shoulder 5/16-18
209	17000612	Screw Hexwsh Thdr 3/8-16 x 3/4
215	172543X615	Bumper
219	17000512	Screw 5/16-18 x 3/4

NOTE: All component dimensions given in U.S.
inches 1 inch = 25.4 mm

REPAIR PARTS

TRACTOR- MODEL NO. 917-277080

DRIVE

KEY NO.	PART NO.	DESCRIPTION	KEY NO.	PART NO.	DESCRIPTION
1	-----	Transaxle (See Breakdown)	77	123583X	Key, Square
		Hydro gear Model 323-0510	78	121748X	Washer 25/32 x 1-5/8 x 16 Ga.
6	17060512	Screw 5/16-18 x 3/4	89	174901X418	Console, Shift
9	174367	Clutch Elec	90	124346X	Nut Self-Thd Wash-hd 1/4 Zinc
15	74490544	Bolt Hex Flghd 5/16-18 Gr. 5	95	180825	Rod Bypass
16	73800500	Nut Lock Hex W/Ins. 5/16-18 Unc	96	4497H	Retainer Spring 1" Zinc/Cad
17	126197X	Washer 1-1/2 OD x 15/32 ID x .250	116	72140608	Bolt RDHD SQNK 3/8-16 Unc x 1
19	73800600	Nut Lock Hex W/Wsh 3/8-16 Unc	120	73900600	Nut Lock Fig 3/8-16 Unc
20	173937	Bolt Hex 7/16-20 x 4 x Gr. 5-1.5	150	175456	Spacer Retainer
21	175036X505	Knob Custom Control Cruise	151	19133210	Washer 13/32 x 2 x 10 Ga.
22	175896	Rod, Brake	202	72110612	Bolt Carr Sh 3/8-16 x 1-1/2 Gr. 5
24	73350600	Nut, Hex Jam 3/8-16 Unc	212	145212	Nut Hex Flange Lock
25	106888X	Spring, Brake Rod	214	174735	Link Transaxle
26	19131316	Washer	215	175646	Cover Pedal Forward
27	76020412	Pin Cotter 1/8 x 3/4 CAD.	217	179433	Pedal Reverse
28	179607	Rod, Parking Brake	218	174713	Arm Control Pedal Reverse
29	17608X505	Knob Brake Parking	219	174839	Bracket Frest Pdl Ctrl. Hyd
30	169592	Bracket, Transaxle	220	174711	Bracket Mtg. Pedal Control
32	74760512	Bolt Hex Hd 5/16-18 Unc x 3/4	221	72140606	Bolt Rdhd Sqnk 3/8-16 Unc x 3/4
33	72140506	Bolt Rdhd Sqnk 5/16-18 Unc x 3/4	222	73680700	Nut Crownlock 7/16-14 Unc
34	175578	Shaft, Foot Pedal	223	174840	Washer Nylon 11/16 ID x .060
35	120183X	Bearing, Nylon	224	174736	Pedal Forward
36	19211616	Washer	225	174712	Arm Control Pedal Forward
37	1572H	Pin, Roll	226	174902	Bolt Pivot Spacer
38	179114	Pulley, Composite, Flat	227	174710	Cam Reverse Pedal LT
39	74760648	Bolt Fin Hex 3/8-16 Unc x 3	228	179032	Bolt Shoulder 5/16-18
41	175556	Keeper, Belt Idler Flat	229	176451	Washer Serrated 5/16 x .75
47	127783	Pulley, Idler, V-Groove	231	174573	Strap Torque
48	154407	Bellcrank Clutch Grnd Drw Stl	232	175570	Actuator Cruise Disengage
49	123205X	Retainer, Belt	233	174856	Pawl Control Cruise
50	74760624	Bolt	234	174858	Lever Control Cruise
51	73680600	Nut Crownlock 3/8-16 UNC	235	174857	Sector Control Cruise
52	73680500	Nut, Crownlock 5/16-18 Unc	236	128903	Bolt Shoulder 3/8-16 Unc 1/44
53	105710X	Link, Clutch	237	170165	Bolt Shoulder 5/16-18
55	105709X	Spring, Return, Clutch	238	175807	Arm Mtg. Cruise Sector
56	17060620	Screw 3/8-16 x 1-1/4	239	17490508	Screw Thdrol 5/16 x 1/2
57	140294	V-Belt, Ground Drive	240	175610	Spring Return Cruise Control
59	169691	Keeper, Center Span	241	73930400	Nut Centerlock 1/4-20 Unc
61	17120614	Screw 3/8-16 x .875	242	74780412	Bolt Fin Hex 1/4-20 Unc x 3/4
62	123533X	Cover, Pedal	243	178289	Bracket Anti-Rotation CVX
63	175417	Pulley, Engine	244	166880	Screw 5/16-18 x 5/8
65	10040700	Washer	250	17060612	Screw 3/8-16 x 3/4
66	154778	Keeper Belt Engine	253	179422	Washer .3125 x .615 x 16 Ga
74	137057	Spacer, Axle	254	178062	Clip Retainer
75	121749X	Washer 25/32 x 1-1/4 x 16 Ga.			
76	12000001	E-Ring			

NOTE: All component dimensions given in U.S. inches
1 inch = 25.4 mm

REPAIR PARTS

TRACTOR- -MODEL NO. 917. 277080

STEERING

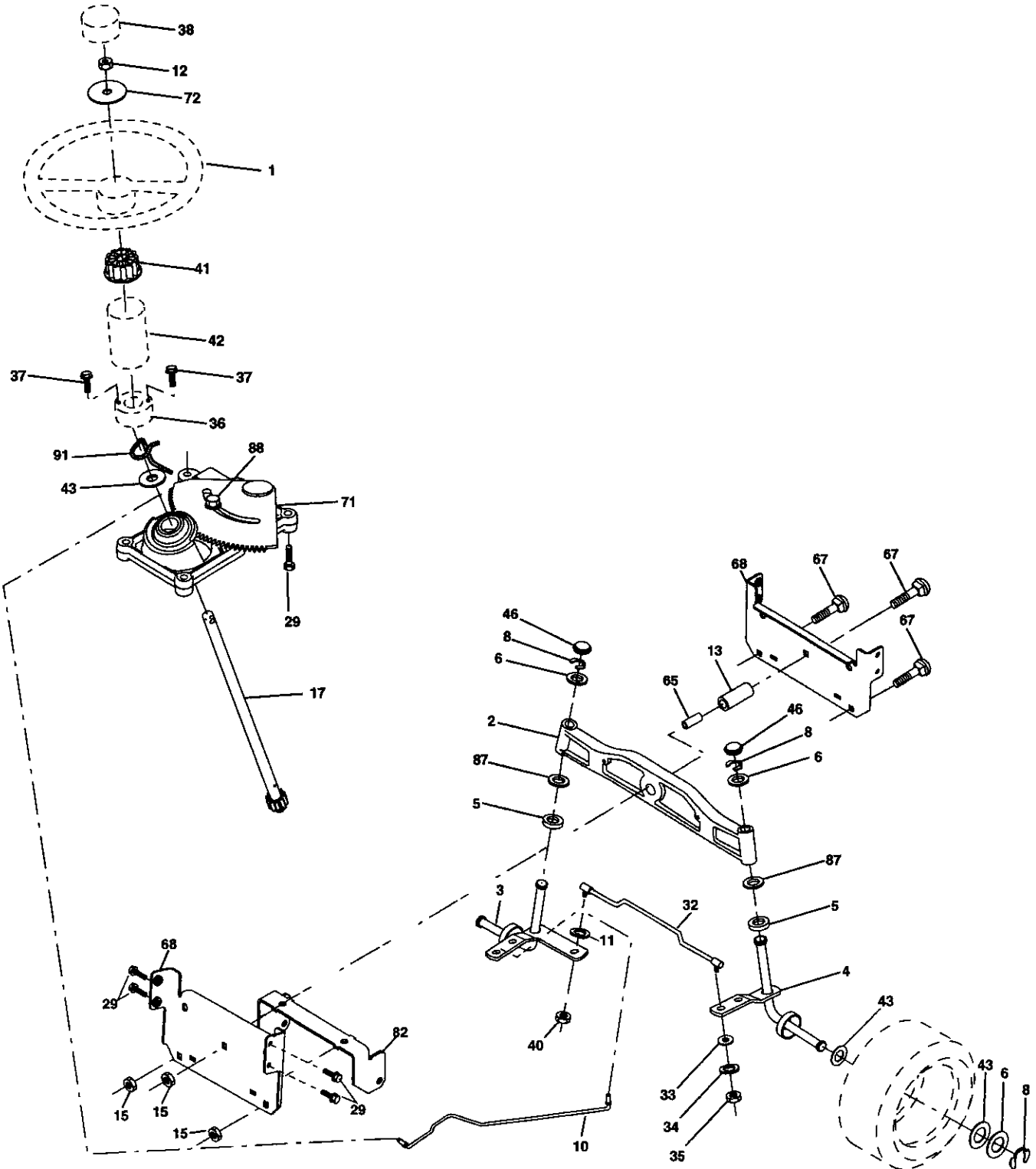

REPAIR PARTS

TRACTOR- -MODEL NO. 917. 277080

STEERING

KEY NO.	PART NO.	DESCRIPTION
1	175139X418	Steering Wheel
2	172393	Axle Assembly
3	169840	Spindle Assembly, L.H.
4	169839	Spindle Assembly, R.H.
5	6266H	Bearing, Race, Thrust, Hardened
6	121748X	Washer 25/32 x 1-5/8 x 16 Gauge
8	12000029	Ring, Klip
10	175121	Draglink
11	STD551137	Washer, Lock
12	73940800	Nut Hex Jam Toplock 1/2-20 Unf
13	136518	Spacer Brg Axle Front
15	145212	Nut Hexflange Lock
17	177883	Shaft Assembly, Steering
29	17060612	Screw, 3/8-16 x 3/4
32	170162	Rod, Tie
33	19111216	Washer 11/32 x 3/4 x 16 Ga.
34	STD551131	Washer Lock Hvy Spr. 5/16
35	73540500	Crownlock Nut 5/16-24 Unf
36	155105	Bushing, Steering
37	152927	Screw
38	175140X418	Insert, Steering Wheel
40	STD541537	Nut Lock Center 3/8-24 Unf
41	159945	Adaptor, Steering Wheel
42	174530X418	Boot, Steering Shaft
43	121749X	Washer 25/32 x 1-1/4 x 16 Gauge
46	121232X	Cap, Spindle
65	160367	Spacer Brace Axle
67	72140618	Bolt Rdhd Sq 3/8-16 UNC x 2-1/4
68	169827	Axle, Brace
71	175146	Steering Asm
72	19182411	Washer 9/16 Id x 1-1/2Od 11 G Zin
82	169835	Bracket Susp Chassis Front
87	173966	Washer Flat .781 x 1-1/2 x .14
88	175118	Bolt Shoulder 7/16-20 Unc
91	175553	Clip Steering

NOTE: All component dimensions given in U.S. inches 1 inch = 25.4 mm

REPAIR PARTS

TRACTOR- -MODEL NO. 917. 277080

ENGINE

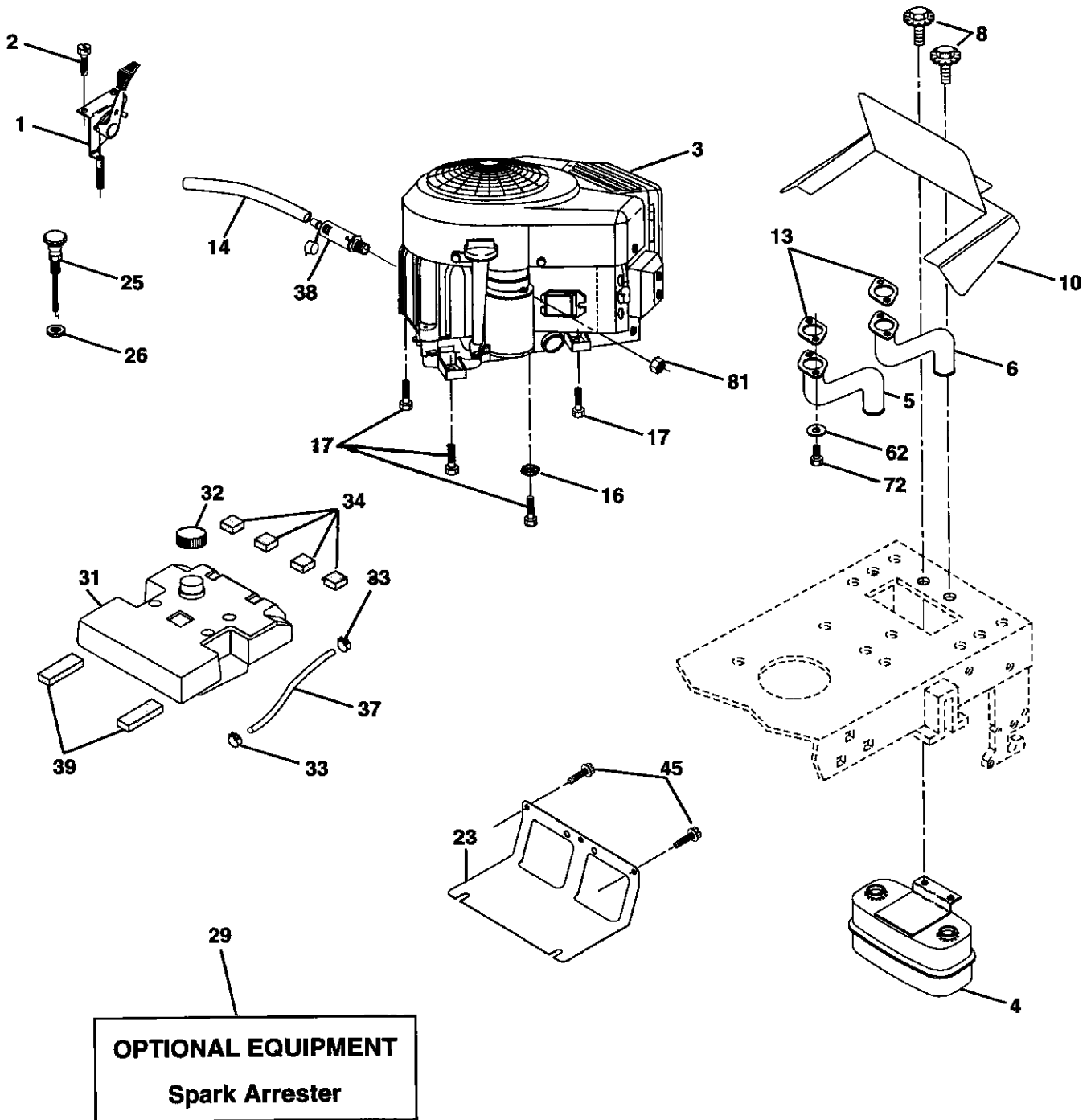

REPAIR PARTS

TRACTOR- -MODEL NO. 917. 277080

ENGINE

KEY NO.	PART NO.	DESCRIPTION
1	175437X505	Control, Throttle
3	-----	Engine, (See Breakdown) B&S Model Number 446777-0197-E1
4	149723	Muffler
5	159955	Pipe Exhaust Lh
6	160589	Pipe Exhaust Rh
8	171877	Bolt 5/16-18 Unc x 3/4
10	162797	Shield Heat
13	165391	Gasket (See Engine Breakdown)
14	148456	Tube Drain Oil Easy
16	11050600	Washer, Lock, External Tooth 3/8
17	17060624	Screw Thdrol 3/8-16 x 1-1/2
23	169837	Shield, Browning / Debris Guard
25	175440X505	Choke Control
26	73920600	Nut, Keps 3/8-24 Unf
29	137180	Kit, Spark Arrestor
31	157103	Tank Fuel
32	161696	Cap Asm Fuel
33	123487X	Clamp, Hose
34	106082X	Pad, Spacer
37	8543R	Line, Fuel
38	148315	Plug Drain Oil Easy
39	109227X	Pad, Idler
45	17000612	Screw Hexwsh Thdr 3/8-16 x 3/4
62	10040500	Washer Lock 5/16
72	71070512	Screw Hex Cap 5/16-18 x 3/4
81	73510400	Nut Keps Hex 1/4-20 UNC
102	164863	Screw Hwhd H.-Lo #13016 x 3/4

NOTE: All component dimensions given in U.S. inches 1 inch = 25.4 mm

REPAIR PARTS

TRACTOR- -MODEL NO. 917. 277080

SEAT ASSEMBLY

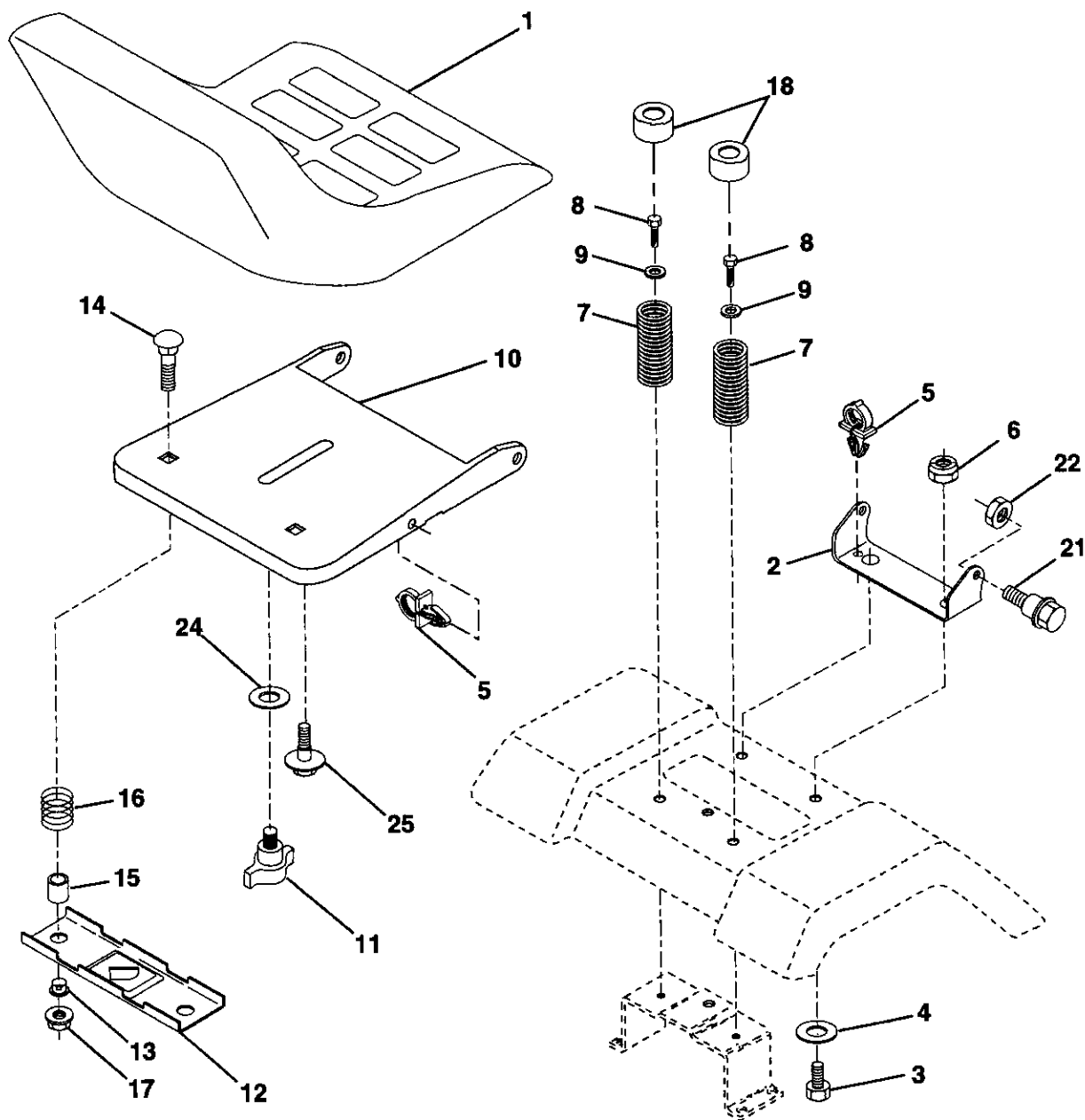

KEY NO.	PART NO.	DESCRIPTION
1	175134	Seat
2	140551	Bracket, Pivot, Seat
3	71110616	Bolt
4	19131610	Washer 13/32 x 1 x 10 Gauge
5	145006	Clip, Push-In Hinged
6	STD541437	Nut
7	124181X	Spring, Seat
8	17000616	Screw 3/8-16 x 1-1/2
9	19131614	Washer 13/32 x 1 x 14 Gauge
10	182493	Pan, Seat
11	177957	Knob Seat
12	121246X	Bracket, Switch Mounting

KEY NO.	PART NO.	DESCRIPTION
13	121248X	Bushing, Snap
14	72050412	Bolt, Carriage 1/4-20 x 1-1/2
15	121249X	Spacer, Split
16	123740X	Spring
17	123976X	Locknut, Flange 1/4 Grade 5
18	124238X	Cap Spring Seat
21	171852	Bolt, Shoulder 5/16-18 UNC
22	STD541431	Nut
24	19171912	Washer 17/32 x 1-3/16 x 12 Gauge
25	127018X	Bolt, Shoulder 5/16-18 x .62

NOTE: All component dimensions given in U.S. inches
1 inch = 25.4 mm

REPAIR PARTS

TRACTOR- -MODEL NO. 917. 277080

DECALS

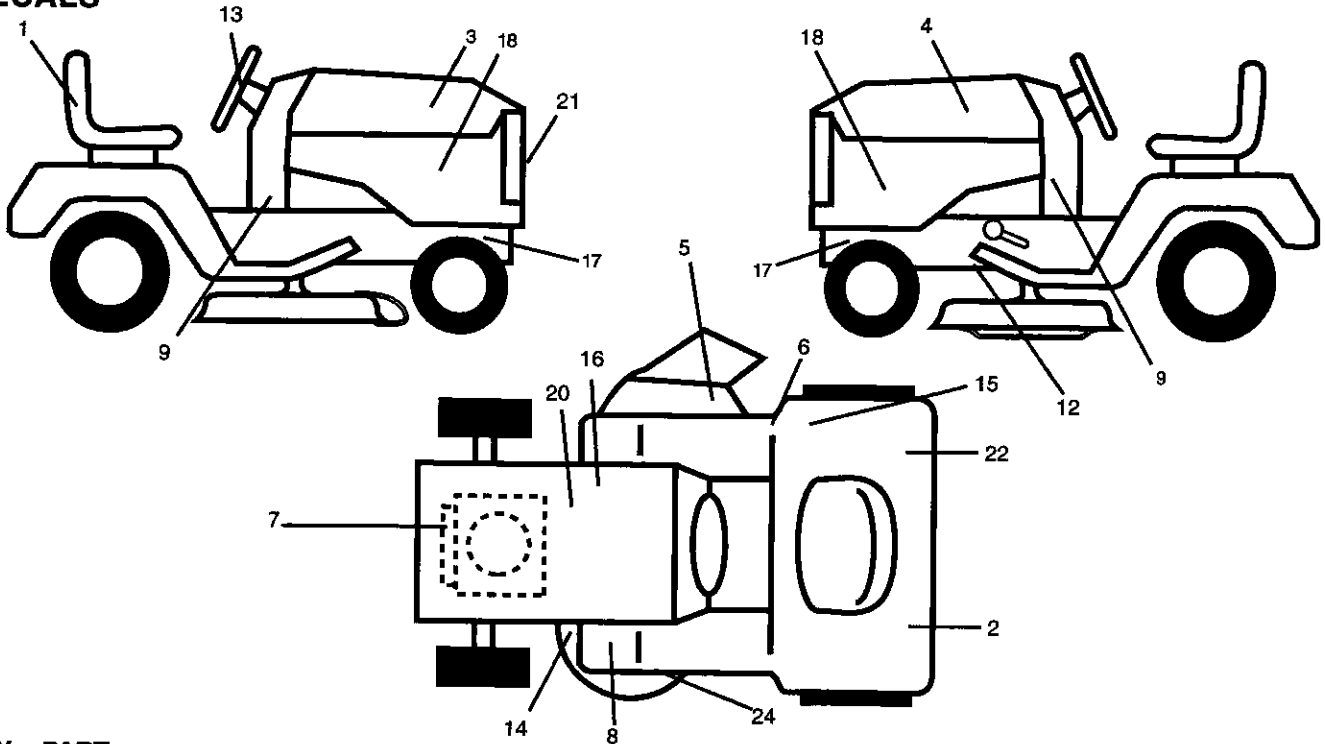

KEY NO.	PART NO.	DESCRIPTION
1	180978	Decal, Seat
2	174969	Reflector L.H.
3	177909	Decal, Hood, R.H.
4	177910	Decal, Hood, L.H.
5	182166	Decal, Cut Finger
6	145498	Decal, Read Owners
7	181572	Decal, B&S 25 ELS
8	159737	Decal, Brake Clutch
9	182136	Decal, Dash Lwr
12	146046	Decal, V-Belt Drive Schematic
13	177890	Decal Strg Wheel
14	175291	Decal, V-Belt Schematic
15	180433	Decal, DBA
16	138047	Decal, Battery Diehard

KEY NO.	PART NO.	DESCRIPTION
17	159736	Decal, Chassis Hot Muffler
18	177913	Decal, Panel Side
20	145005	Decal, Battery Dngr/Psn Sym
21	177889	Decal, Grille
22	174970	Reflector RH
24	178482	Decal, Deck Heavy Duty
--	138311	Decal, Lift Handle
--	162598	Decal, Draw Bar Load
--	174998X418	Pad Footrest LH
--	175542X418	Pad Footrest RH
--	169210	Decal, By Pass Lt Hydro
--	183117	Manual Oper Euro
--	183118	Manual Oper Scand
--	183119	Manual Repair Parts

WHEELS & TIRES

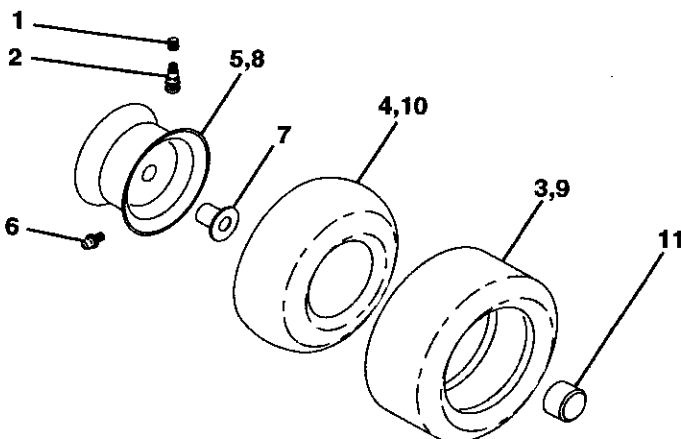

KEY NO.	PART NO.	DESCRIPTION
1	59192	Valve Cap, Tire
2	65139	Stem, Valve
3	177750	Tire, Front
4	59904	Tube, Front Tire (Not Provided, Service Item Only)
5	106732X417	Rim, Front
6	278H	Fitting, Grease (Front Wheel Only)
7	9040H	Bearing, Flange (Front Wheel Only)
8	106108X417	Rim, Rear
9	177751	Tire, Rear
10	7152J	Tube, Rear Tire (Not Provided, Service Item Only)
11	104757X417	Cap, Axle
--	144334	Sealant, Tire 10 oz.

NOTE: All component dimensions given in U.S. inches
1 inch = 25.4 mm

REPAIR PARTS

TRACTOR- -MODEL NO. 917. 277080

LIFT ASSEMBLY

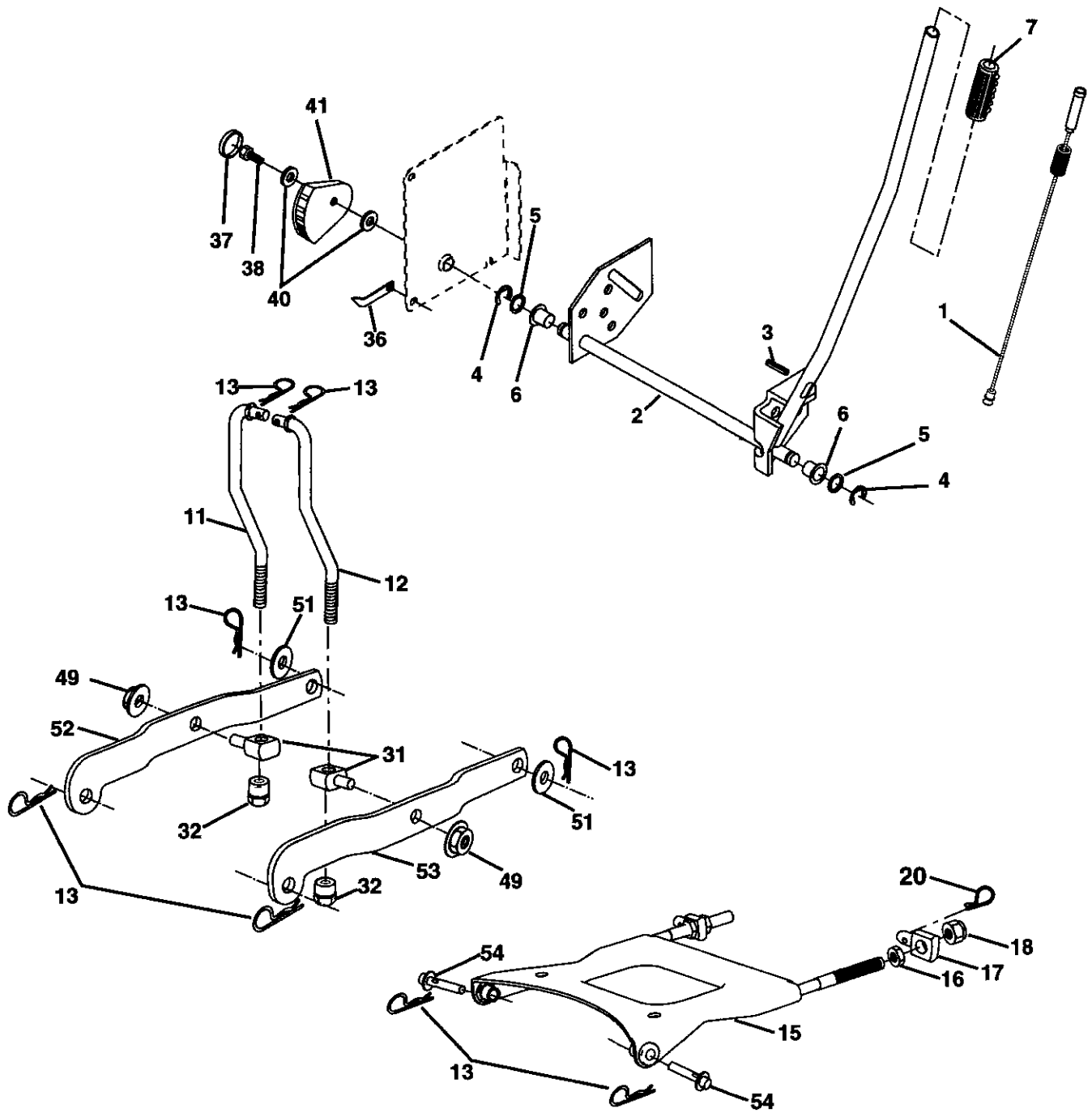

REPAIR PARTS

TRACTOR- -MODEL NO. 917. 277080

LIFT ASSEMBLY

KEY NO.	PART NO.	DESCRIPTION
1	179504	Plunger Assembly
2	159476	Shaft Assembly, Lift
3	178981	Pin, Groove
4	12000002	E-Ring
5	19211621	Washer 21/32 x 1 x 21 Gauge
6	120183X	Bearing, Nylon
7	175830	Grip, Handle, Fluted
11	175370	Link, Lift, L.H.
12	175371	Link, Lift, R.H.
13	4939M	Retainer Spring
15	175562	Plate Asm Suspension Front
16	73350800	Nut Jam Hex 1/2-13 Unc
17	175689	Trunnion Front Susp.
18	73800800	Nut Lock w/Wsh 1/2-13 Unc
20	163552	Retainer Spring
31	176205	Trunion Sups. Arm.
32	175994	Nut Lift Link 7/16-20
36	155097	Pointer Height Indicator
37	123935X	Plug Hole
38	17060516	Screw 5/16-18 x 1
40	19112410	Washer 11/32 x 1-1/2 x 10 Ga
41	155098	Indicator Height Stlt
49	145212	Nut Hex/Large Lock
51	19171416	Washer 17/32 x 7/8 x 16 Ga.
52	175378	Arm Suspension Rear LH
53	175802	Arm Suspension Rear RH
54	175560	Pin Flange

NOTE: All component dimensions given in U.S. inches
1 inch = 25.4 mm

REPAIR PARTS

TRACTOR- -MODEL NO. 917. 277080

MOWER DECK

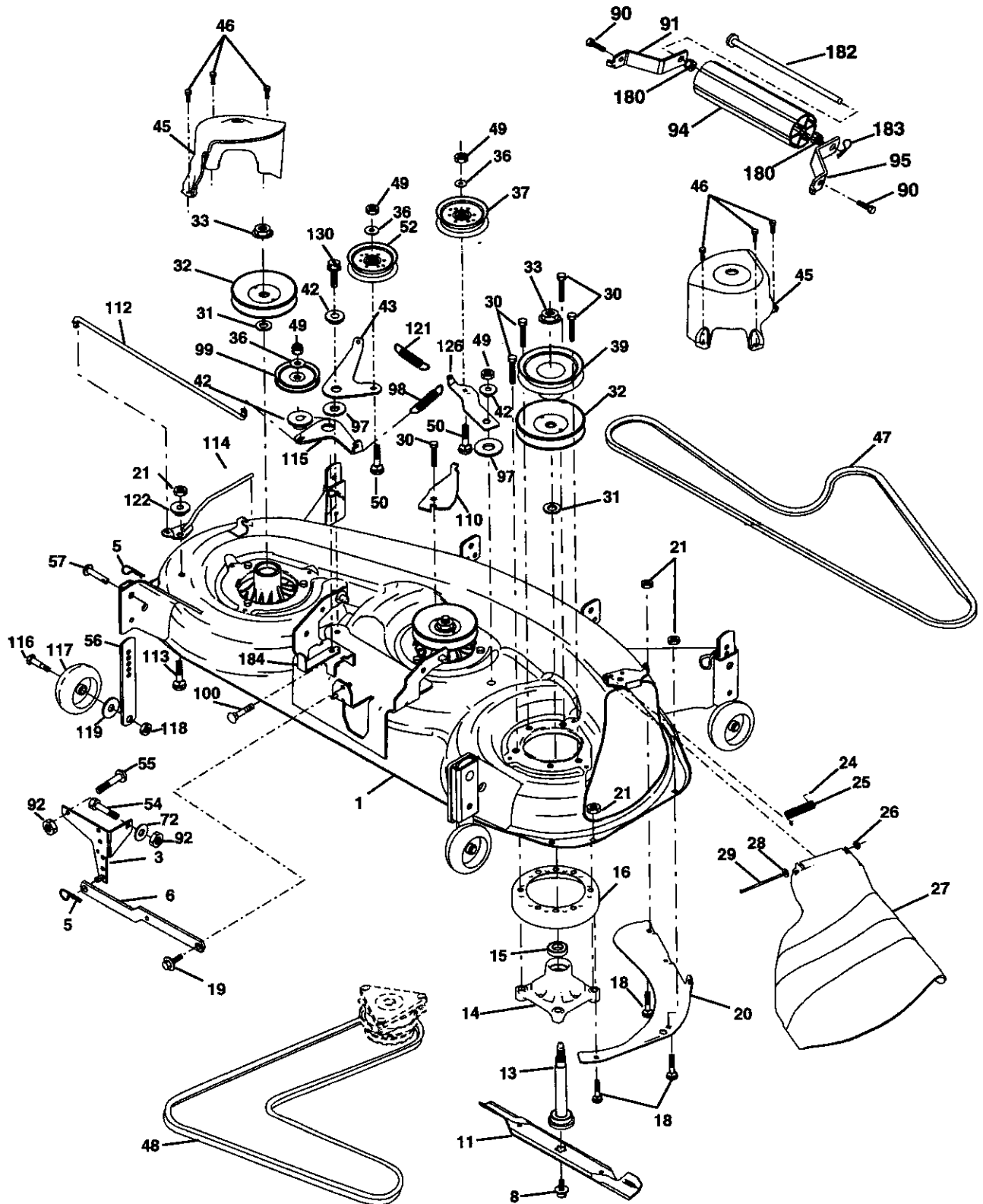

REPAIR PARTS

TRACTOR- -MODEL NO. 917. 277080

MOWER DECK

KEY NO.	PART NO.	DESCRIPTION	KEY NO.	PART NO.	DESCRIPTION
1	180358	Deck Weldment Mower 48	56	155986	Bar Pnt Adj.
3	138017	Bracket Asm., Sway Bar	57	156941	Pin Head Rivet
5	4939M	Retainer Spring	72	19131312	Washer 13/32 x 13/16 x 12
6	178024	Sway Bar Deck	90	74760516	Bolt Hex Hd 5/16-18Unc x 1
8	174365	Bolt 7/16 Asm. Blade	91	180534	Bracket Asm Noseroller LH
7392 11	180054	Blade	92	73800600	Nut Lock Hex W/Ins 3/8-16
13	174360	Shaft Mandrel Asm. Greaseable	94	176066	Noseroller
14	174358	Housing Mandrel	95	180535	Bracket Asm Noseroller RH
15	110485X	Bearing, Ball, Mandrel	97	133943	Washer Hardened
16	174493	Stripper Mandrel Deck	98	179479	Spring Primary Drive
18	72140505	Bolt, Carriage 5/16-18 x 5/8	99	181775	Pulley Idler"V"
19	132827	Bolt, Hex Hd, Shoulder 5/16-18	100	72110616	Bolt RDHD Sqnk 3/8-16 UNC x 2
20	174378	Baffle, Vortex Mower	108	72110404	Bolt Carr.
21	73680500	Nut, Crownlock 5/16-18 UNC	109	73680400	Nut Crownlock 1/4-20
24	105304X	Cap, Sleeve	110	175016	Arm Spring Secondary
25	178102	Spring, Torsion	112	174387	Link Tension Relief Lever
26	110452X	Nut, Push	113	72110508	Bolt Carr. 5/16-18 x 1
27	180655X428	Deflector Shield	114	174384	Tension Asm Relief Lever
28	19111016	Washer 11/32 x 5/8 x 16 Ga.	115	174609	Arm Spring Tension Relief
29	131491	Rod, Hinge	116	137644	Bolt, Shoulder
30	173984	Screw, Thdroll Washer Head	117	174873	Gauge Wheel
31	129963	Washer, Spacer Mower Vented	118	73930600	Nut, Centerlock 3/8-16 UNC
32	177865	Pulley, Mandrel	119	19121414	Washer 3/8 x 7/8 x 14 Ga.
33	178342	Nut, Flg. Top Lock Cntr. 9/16	121	174371	Spring Secondary Drive
36	19131316	Washer 13/32 x 13/16 x 16 Ga.	122	174606	Bushing Pivot Tension Relief
37	177968	Pulley, Idler, Flat	126	174372	Arm, Idler, Primary Deck
39	174375	Pulley, Idler, Driven	130	17000616	Screw 3/8-16 x 1.0
42	165723	Spacer, Retainer	180	73800500	Nut Lock Hx W/Ins 5/16-18 Unc
43	174373	Arm, Idler Secondary	182	179127	Rod Roller Nose
45	174343	Cover, Mandrel Deck	183	163552	Retainer Spring
46	137729	Screw, Thdroll. 1/4-20 x 5/8	184	173979	Keeper Belt Idler
47	180808	V-Belt, Mower, Secondary	--	181579	Replacement Mower, Complete
48	174368	V-Belt, Mower, Primary	--	174356	Mandrel Asm. Service (Includes Key Nos. 13-15)
49	73680600	Nut, Crownlock 3/8-16 UNC			
50	72110612	Bolt, Carr. 3/8-16 x 1-1/2 Gr. 5			
52	175820	Pulley Idler Flat			
54	74780616	Bolt Fin Hex 3/8-16 x 1			
55	72140608	Bolt RDHD SQNK 3/8-16 x 1			

NOTE: All component dimensions given in U. S. inches 1 inch = 25.4 mm

REPAIR PARTS

TRACTOR- -MODEL NO. 917. 277080

HYDRO GEAR TRANSAXLE - - MODEL NUMBER 323-0510

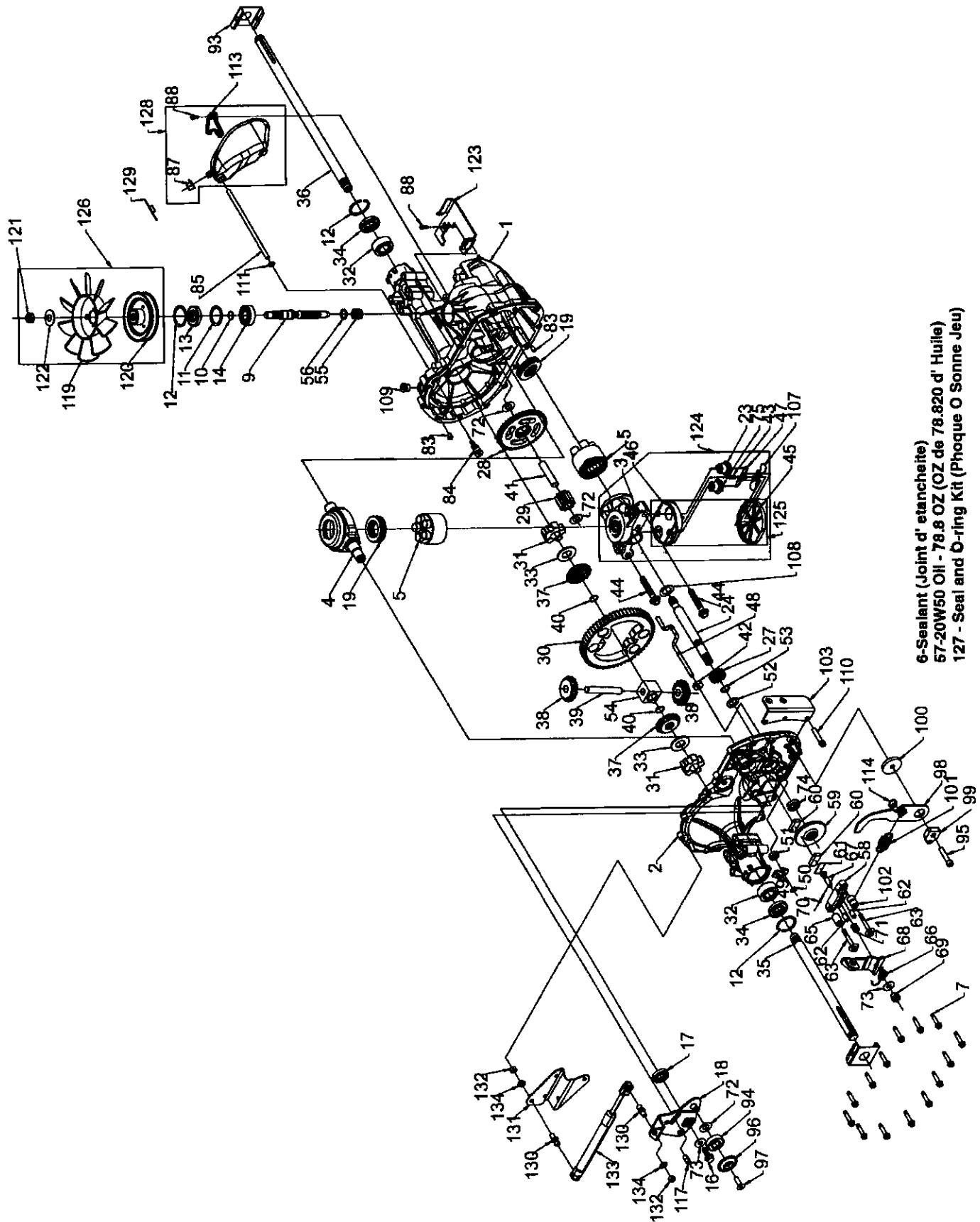

6-Sealant (Joint d' etancheite)
57-20W50 Oil - 78.8 OZ (OZ de 78.820 d' Huile)
127 - Seal and O-ring Kit (Phoque O Sonne Jeu)

REPAIR PARTS

TRACTOR- -MODEL NO. 917. 277080

HYDRO GEAR TRANSAXLE - - MODEL NUMBER 323-0510

KEY NO.	PART NO.	DESCRIPTION	KEY NO.	PART NO.	DESCRIPTION
1	170351	Main Housing, Assembly	68	178782	Arm, Brake
2	170352	Side Housing, Assembly	69	170415	Slotted Hex Nut 5/16-24
3	170353	Center Section, Assembly	70	170416	Cotter Pin 3/32 X 3/4
4	170354	Swashplate, Trunion Machined	71	170417	Compression Spring Brake Anti-Drag
5	169898	Block - Assembly	72	170418	Washer, Ht .5 I.D. X 1 O.D. X .032
6	170355	Sealant 10.5 Oz	73	142884	Flat - Washer 11/32 I.D. X 7/8 O.D
7	170356	Hex Flange Screw 1/4-20 X 1.25	74	170419	Oil Seal .625 X 1.0 X .25
8	170357	Stud, 5/16-24 Hex Double End	75	170420	Check Plug Assembly, .027, Washer
9	170358	Shaft, Input	76	170421	Stud, 5/16-24 Friction Pack
10	170359	Ring - Retaining	77	170422	Puck, .330 X 1.50 X .0975
11	170360	Spacer	78	142969	Spring, Helical Comp
12	169870	Ring - Retaining	79	142980	Spacer
13	170361	Seal, Lip .67 X 1.58 X .276	80	150778	Hex Lock Nut 5/16-24Unjfl(Nylon Insert)
14	169869	Ball Brg 17mm Id X 40mm Od X 12mm	81	170423	Wedge, Friction Pack
16	170362	Hex Flange Head Screw 5/16-24X0.75	82	170424	Clip, Washer .316x1.50x.1046 (Plated)
17	170363	Lip Seal 18 X 32 X 7	83	161168	Pin, Standard Headless
18	178781	Arm, Control	84	170425	Fitting, 5/16 Sae 5/32 Tube
19	150771	Bearing, 30x52x13 Thrust	85	170426	Hose, Expansion Tank
23	170365	Check Plug Assembly, Washer	87	142917	Cap - Poppet Valve
24	170366	Shaft, Motor	88	170429	Bolt, Self Tapping 10-32 X 1/2
27	170367	Gear - Pinion, 13t	90	170430	Puck, Inner Wedge
28	170368	10T/48t Gear	93	170431	Spring Clip - Housing Thrust
29	170369	Gear, 10t Jackshaft	94	178783	Bearing, Ball
30	170370	60t Bull Gear	95	178784	Screw, Socket Head Cap 5/16-24X1-1/2
31	170371	Sleeve Bearing .75 X 1.575 X .625	96	178786	Spacer, Locating
32	170389	Sleeve Bearing(Outboard) .75x1.750x.625	97	178787	Screw, SFHCS 5/16-18 X1
33	142991	Washer, 3/4 Id X 1-1/2 Od X .13 Thk	98	178789	Arm Return
34	170390	Lip Seal Axle Seal	99	178792	Puck, Adjusting
35	170391	Shaft, Axle .75 X 11.39 (Key, R.H.)	100	178793	Washer, .24 ID X 1.60 OD X .239
36	170392	Shaft, Axle .75 X 16.99 (Key, L.H.)	101	178794	Spring, Extension
37	150792	Miter Gear (Splined)	102	178795	Spacer .260 ID X .560 OD X .870
38	150793	Miter Gear 15t (0.5 Id)	103	178796	Bracket, Torque
39	150809	Shaft	107	170432	Deflector
40	170393	Ring, Spiral Retaining	108	170433	Washer, Motor Shaft .71idx1.150dx.030thk
41	170394	Pin, Jackshaft	109	170434	Plug, Sae #6
42	170395	Magnet, Ring	111	170435	O-Ring .07 X .301 I.D.
43	170396	Spring, Bypass	113	170437	Bracket, Support Expansion Tank
44	150797	Hydro Mtg Screw 3/8-24 X 2.5 Long	114	178797	Spring
45	170397	Filter	116	170438	Silicon Sponge
46	170398	Base, Filter	117	178799	Pin, Spring
47	170399	Actuator, Bypass	119	170439	Fan, 7 In.
48	170400	Rod, Bypass Actuator	120	170440	Pulley
49	170401	Arm, Bypass	121	170441	Hex Lock Nut 1/2-20 (Nylon Insert)
50	170402	Retaining Ring .250 External	122	170442	Washer, Belleville
51	170403	Seal, Lip .741 X .250 X .250 Tc	123	178800	Belt Keeper
52	170404	Flat Washer, 5/8 Id X 1.0 Od X .05 Thk	124	170444	Center Section-Filter-Bypass Assembly
53	170405	Retaining Ring	125	170445	Filter Assembly
54	170406	Bearing, Center Block	126	170446	Fan - Pulley Service Assembly
55	142977	Spring - Helical Compression	127	170447	Seal - O-Ring Kit
56	142978	Washer	128	173165	Kit, Expansion Tank
57	150798	20w-50 Oil	130	178802	Stud Ball
58	170407	Brake Yoke	131	178803	Bracket, Cruise Damper
59	170408	Rotor, Brake	132	178804	Hex Nut 5/16-18 NC
60	142883	Brake Puck	133	178806	Damper
61	142882	Puck Plate	134	178808	Washer, Helical Spring Lock 5/16
62	142887	Brake Actuating Pin	900	173839	Transaxle Complete
63	170410	Hfacs 1/4-20x2 W/Patch, Special Flange			
64	142892	Bolt, 1/4-20 X 1 W/Patch			
65	170411	Spacer			
66	170412	Spring, Brake Arm Bias			
67	170413	Sq. Hd. Bolt 5/16-24-Ribbed			

NOTE: All component dimensions given in U.S. inches
1 inch = 25.4 mm

REPAIR PARTS

TRACTOR- -MODEL NO. 917. 277080

BRIGGS & STRATTON ENGINE-MODEL NUMBER 446777 TYPE NUMBER 0197-E1

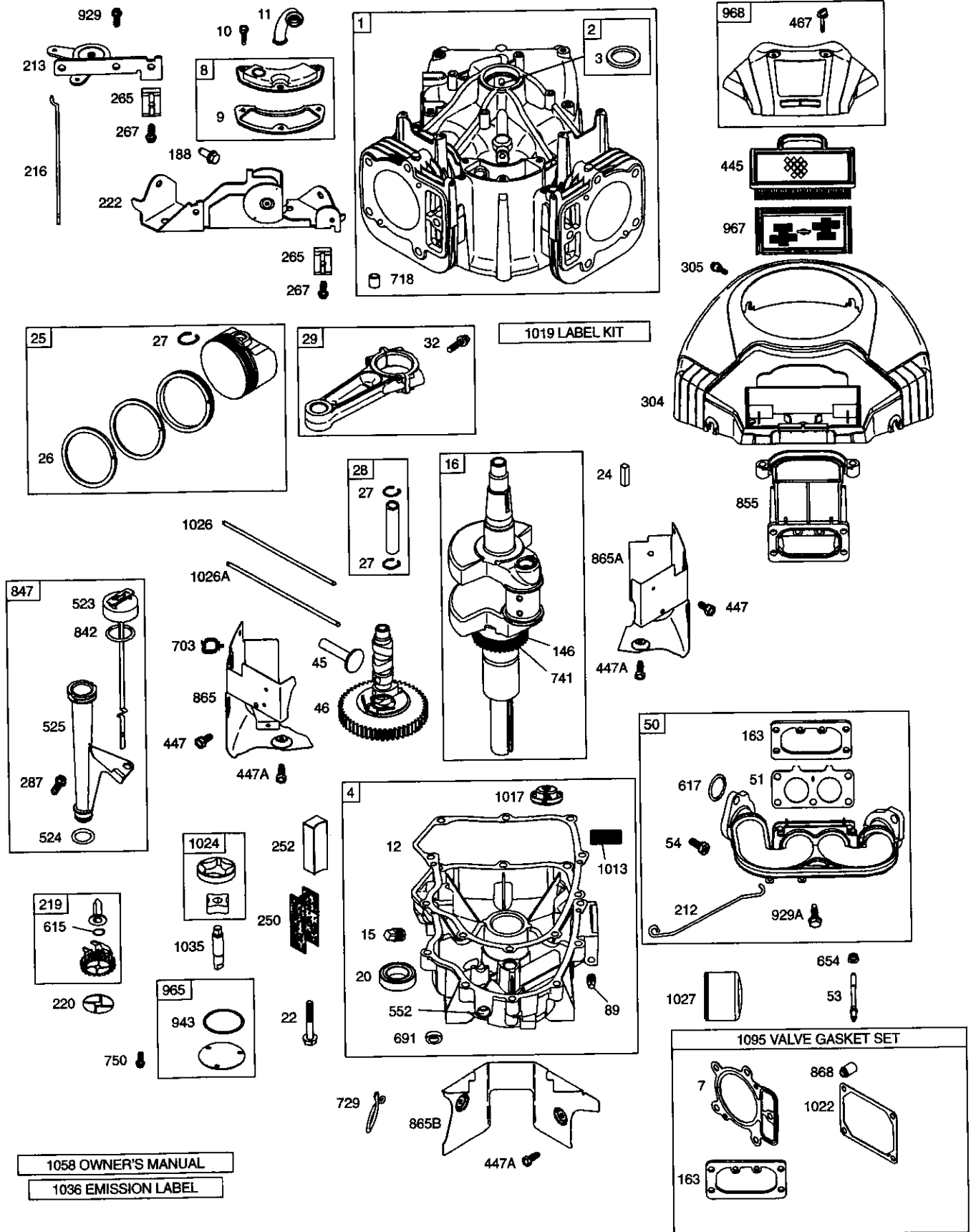

REPAIR PARTS

TRACTOR- -MODEL NO. 917. 277080

BRIGGS & STRATTON ENGINE-MODEL NUMBER 446777 TYPE NUMBER 0197-E1

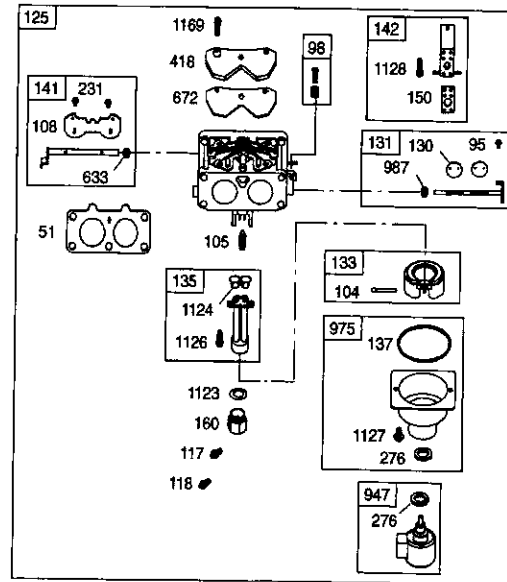
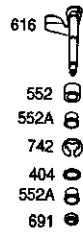
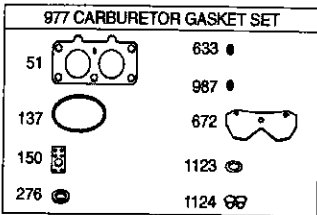
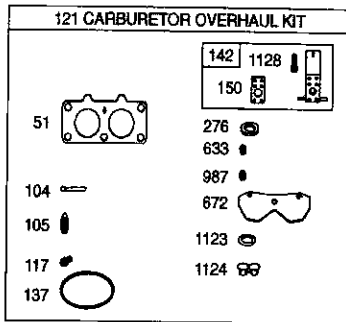
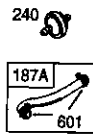
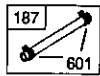
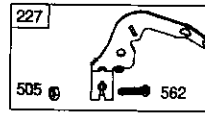
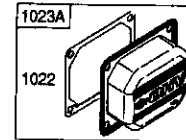
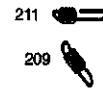
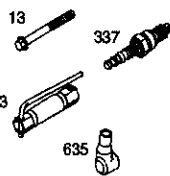
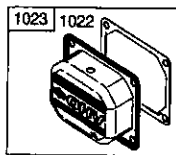
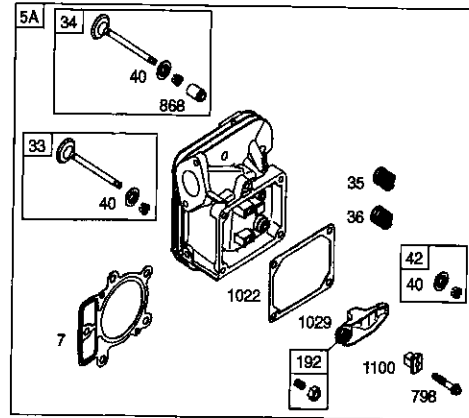
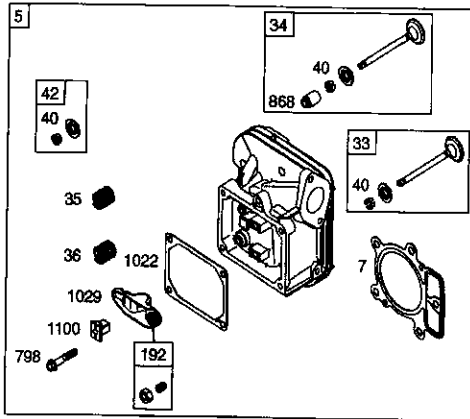

REPAIR PARTS

TRACTOR- -MODEL NO. 917. 277080

BRIGGS & STRATTON ENGINE-MODEL NUMBER 446777 TYPE NUMBER 0197-E1

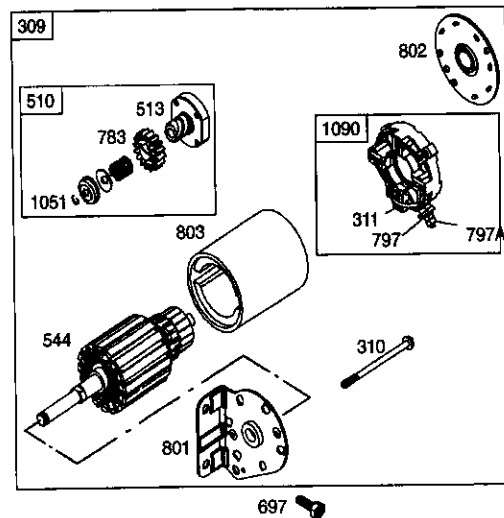
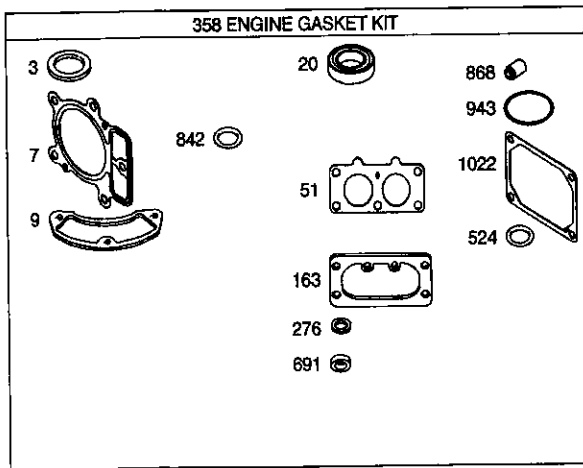
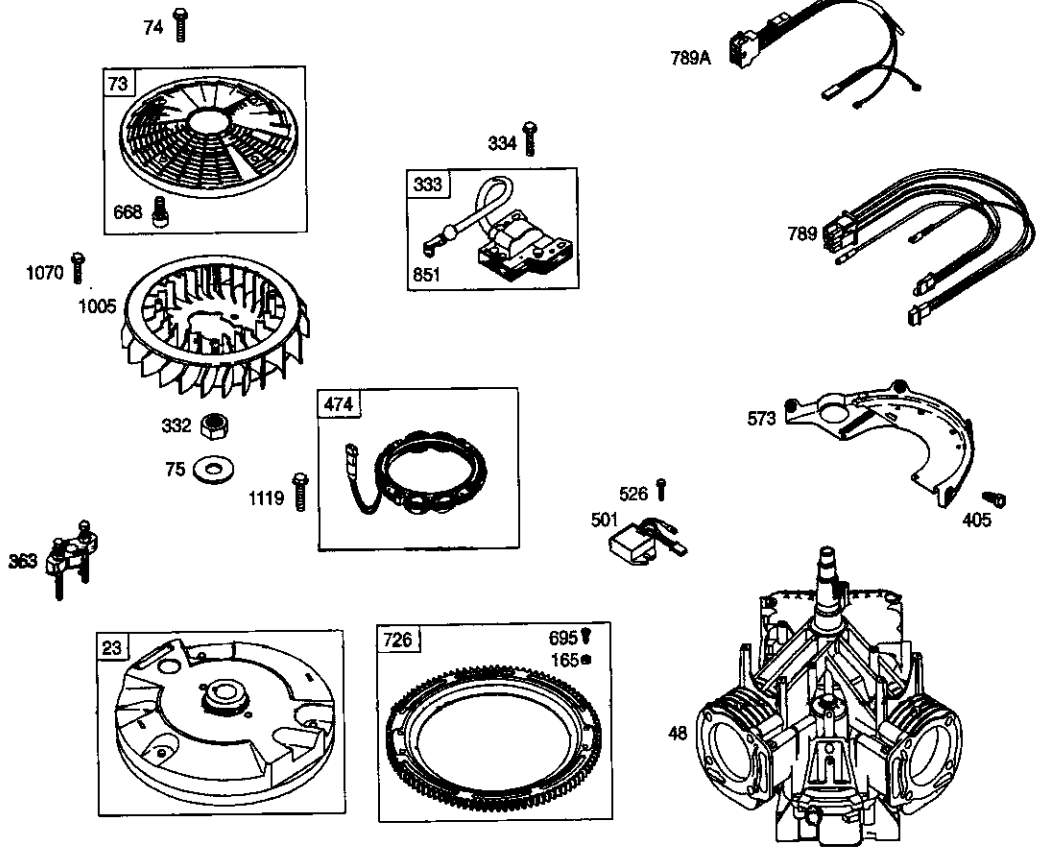

REPAIR PARTS

TRACTOR- -MODEL NO. 917. 277080

BRIGGS & STRATTON ENGINE-MODEL NUMBER 446777 TYPE NUMBER 0197-E1

KEY NO.	PART NO.	DESCRIPTION	KEY NO.	PART NO.	DESCRIPTION
1	694001	Cylinder Assembly	125	499804	Carburetor
2	499585	Kit-Bushing/Seal (Magneto Side)	130	690993	Valve-Throttle
3	391086	• Seal-Oil (Magneto Side)	131	499805	Kit-Throttle Shaft
4	690069	Sump-Engine	133	499806	Float-Carburetor
5	697580	Head-Cylinder (Cylinder 1)	135	499803	Tube-Fuel Transfer
5A	697581	Head-Cylinder (Cylinder 2)	137	690994	Ø‡ Gasket-Float Bowl
7	693997	*+ Gasket-Cylinder Head	141	499807	Kit-Choke Shaft
8	499601	Breather Assembly	142	499808	Ø Nozzle-Carburetor
9	690937	• Gasket-Breather	146	690979	Key-Timing
10	690960	Screw (Breather Assembly)	150	690995	Ø‡ Gasket-Nozzle
11	690942	Tube-Breather	160	690996	Retainer-Solenoid
12	697227	Gasket-Crankcase	163	691001	*+ Gasket-Air Cleaner
13	690360	Screw (Cylinder Head)	165	693148	Nut (Ring Gear)
15	690946	Plug-Oil Drain	187	691050	Line-Fuel (Cut to Required Length)
16	691046	Crankshaft	187A	697712	Line-Fuel (Molded)
20	690947	• Seal-Oil (PTO Side)	188	690960	Screw (Control Bracket)
22	694966	Screw (Engine Sump)	192	690083	Adjuster-Rocker Arm
23	691053	Flywheel	209	697674	Spring-Governor
24	222698	Key-Flywheel	211	691019	Spring-Governed Idle
25	697679	Piston Assembly (Standard)	212	695238	Link-Throttle
25	697680	Piston Assembly (.010" Oversize)	213	691021	Bracket-Choke Control
25	697681	Piston Assembly (.020" Oversize)	216	691022	Link-Choke
25	697682	Piston Assembly (.030" Oversize)	219	696376	Gear-Governor
26	697683	Ring Set (Standard)	220	690412	Washer (Governor Lever)
26	697684	Ring Set (.010" Oversize)	222	697678	Bracket-Control
26	697685	Ring Set (.020" Oversize)	227	691048	Lever-Governor Control
26	697686	Ring Set (.030" Oversize)	231	690718	Screw (Choke Valve)
27	690975	Lock-Piston Pin	240	695666	Filter-Fuel
28	690229	Pin-Piston	250	690957	Retainer-Breather
29	499583	Rod-Connecting	252	690956	Collector-Oil
32	690976	Screw (Connecting Rod)	265	691024	Clamp-Casing
33	697576	Valve-Exhaust	267	695134	Screw (Casing Clamp)
34	499597	Valve-Intake	276	690997	*Ø‡ Washer-Sealing
35	690963	Spring-Valve (Intake)	287	690960	Screw (Dipstick Tube)
36	690963	Spring-Valve (Exhaust)	304	695277	Housing-Blower
40	690964	Retainer-Valve	305	691005	Screw (Blower Housing)
42	499586	Keeper-Valve	309	691262	Motor-Starter
45	690977	Tappet-Valve	310	691263	Bolt-Starter Motor
46	690978	Camshaft	311	497608	Brush Set
48		Short Block (Replacement Engine)	332	691059	Nut (Flywheel)
50	695241	Manifold-Intake	333	691060	Armature-Magneto
51	690950	*Ø‡ Gasket-Intake	334	691061	Screw (Magneto Armature)
53	690951	Stud (Carburetor)	337	691043	Spark Plug
54	695240	Screw (Intake Manifold)	358	694012	Set-Engine Gasket
73	691055	Screen-Rotating	363	691062	Flywheel Puller
74	691057	Screw (Rotating Screen)	383	690966	Wrench-Spark Plug
75	691056	Washer (Flywheel)			RPM Settings:
89	690283	Plug-Oil			Low Speed: 1900-2100
95	690718	Screw (Throttle Valve)			High Speed: 3000-3200
98	499802	Kit-Idle Speed			
104	690984	Ø Pin-Float Hinge			
105	690985	Ø Valve-Float Needle			
108	690986	Valve-Choke			
117	690232	Ø Jet-Main (Standard)			
118	690989	Jet-Main (High Altitude)			
121	499811	Kit-Carburetor Overhaul			

- Included in Engine Gasket Set, Key. No. 358
- Ø Included in Carburetor Overhaul Kit, Key. No. 121
- ‡ Included in Carburetor Gasket Set, Key. No. 977
- + Included in Valve Gasket Set, Key. No. 1095

NOTE: All component dimensions given in U.S. inches
1 inch = 25.4 mm

REPAIR PARTS

TRACTOR- -MODEL NO. 917. 277080

BRIGGS & STRATTON ENGINE-MODEL NUMBER 446777 TYPE NUMBER 0197-E1

KEY NO.	PART NO.	DESCRIPTION	KEY NO.	PART NO.	DESCRIPTION
385	690960	Screw (Fuel Pump)	847	499602	Dipstick/Tube Assembly
387	808656	Pump-Fuel	851	493880	Terminal-Sparkplug
404	690442	Washer (Governor Crank)	855	691011	Adapter-Air
405	690960	Screw (Back Plate)	865	691012	Cover-Air Guide
418	690999	Plate-Carburetor	865A	691014	Cover-Air Guide
445	695667	Filter-Air Cleaner Cartridge	865B	691015	Cover-Air Guide
447	691003	Screw (Air Guide Cover)	868	690968	*+ Seal-Valve
447A	690960	Screw (Air Guide Cover)	914	691127	Screw (Rocker Cover)
467	691008	Knob-Air Cleaner	918	694000	Hose-Vacuum
474	696458	Alternator	929	695239	Screw (Choke Control Bracket)
501	691185	Regulator	929A	691003	Screw (Choke Control Bracket)
505	691029	Nut (Governor Control Lever)	943	690589	• Seal-O Ring (Oil Pump Cover)
510	497606	Drive-Starter	947	499809	Solenoid-Fuel
513	692024	Clutch-Drive	965	499613	Cover-Oil Pump
523	691036	Dipstick	967	273638	Filter-Pre Cleaner
524	691032	• Seal-O Ring (Dipstick Tube)	968	499788	Cover-Air Cleaner
525	691037	Tube-Dipstick	975	499810	Bowl-Float
526	690960	Screw (Regulator)	977	499812	Gasket Set-Carburetor
544	-----	Armature-Starter (Service with 691262 Starter Motor)	987	691000	∅‡ Seal-Throttle Shaft
552	690552	Bushing-Governor Crank	1005	499603	Fan-Flywheel
552A	690553	Bushing-Governor Crank	1013	690954	Nipple-Oil Filter
562	690311	Bolt (Governor Control Lever)	1017	690770	Screen-Oil Pump
573	691009	Plate-Back	1019	690103	Kit-Label
601	691038	Clamp-Hose	1022	690971	*+ Gasket-Rocker Cover
615	690317	Retainer-Governor Shaft	1023	499599	Cover-Rocker (Cylinder 1)
616	691045	Crank-Governor	1023A	499600	Cover-Rocker (Cylinder 2)
617	691917	Seal-O Ring (Intake Manifold)	1024	499054	Pump-Oil
628	690960	Screw (Fuel Pump Bracket)	1026	690981	Rod-Push (Steel)
633	690998	∅‡ Seal-Choke/Throttle Shaft	1026A	690982	Rod-Push (Aluminum)
635	66538	Boot-Spark Plug	1027	696854	Filter-Oil
654	690958	Nut (Carburetor)	1029	690972	Arm-Rocker
668	691215	Spacer	1035	691042	Shaft-Pump
672	690234	∅‡ Gasket-Carburetor Plate	1036	695704	Label-Emission
691	690657	• Seal-Governor Shaft	1051	691265	Ring-Retaining
695	693149	Screw (Ring Gear)	1058	274794	Owner's Manual
697	690372	Screw (Drive Cap)	1070	691058	Screw (Flywheel Fan)
703	691010	Clip	1090	691293	Retainer-Brush
718	690959	Pin-Locating	1095	694013	Gasket Set-Valve
726	499612	Gear-Ring	1100	690973	Pivot-Rocker Arm
729	694123	Clip-Wire	1119	691183	Screw (Alternator)
741	690980	Gear-Timing	1123	690987	∅ ‡ Seal-O Ring (Solenoid Retainer)
742	690328	Retainer-E Ring	1124	690988	∅ ‡ Seal-O Ring (Fuel Transfer Tube)
750	696999	Screw (Oil Pump Cover)	1126	690991	Screw (Fuel Transfer Tube)
783	693058	Gear-Pinion	1127	690992	Screw (Float Bowl)
788	691039	Bracket-Fuel Pump	1128	690990	∅ Screw (Carburetor Nozzle)
789	695050	Harness-Wiring	1169	693140	Screw (Carburetor Cover Plate)
789A	696576	Harness-Wiring			RPM Settings: Low Speed: 1900-2100 High Speed: 3000-3200
797	691029	Nut (Brush Retainer)			
797A	693167	Nut (Brush Retainer)			
798	690967	Screw (Rocker Arm)			
801	691283	Cap-Drive			
802	691286	Cap-End			
803		Housing-Starter (Service with 691262 Starter Motor)			
842	691031	• Seal-O Ring (Dipstick Tube)			

- Included in Engine Gasket Set, Key. No. 358
- ∅ Included in Carburetor Overhaul Kit, Key. No. 121
- ‡ Included in Carburetor Gasket Set, Key. No. 977
- + Included in Valve Gasket Set, Key. No. 1095

NOTE: All component dimensions given in U.S. inches
1 inch = 25.4 mm