

REPAIR PARTS MANUAL
MODEL NO. 277440
Lawn Tractor

26HK HYD 42" 2004

CRAFTSMAN®

HOW TO USE THIS MANUAL

This manual is designed to provide the customer with a means to identify the parts on his/her tractor when ordering repair parts. The illustrations may or may not represent the actual assemblies; therefore, it is not recommended to use this manual as a guide to assemble or disassemble the tractor. Some hardware and parts are drawn larger in order to more readily identify them.

Each tractor has its own model number.

The model number for your tractor can be found on the fender under the seat.

When ordering parts, always give the following information:

- Product - "Tractor"
- Model Number - "277440"
- Part Number
- Part Description

TABLE OF CONTENTS

SCHEMATIC	3
ELECTRICAL.....	4-5
CHASSIS.....	6-7
DRIVE.....	8-9
STEERING	10-11
SEAT	12
DECALS.....	13
ENGINE.....	14-15
MOWER LIFT	16-17
MOWER DECK	18-19
TRANSAXLE.....	20-21
ENGINE BREAKDOWN.....	22-26
WARRANTY	27

TRACTOR- -MODEL NO. 917. 277440

SCHEMATIC

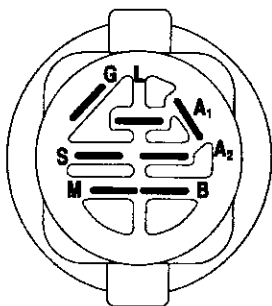
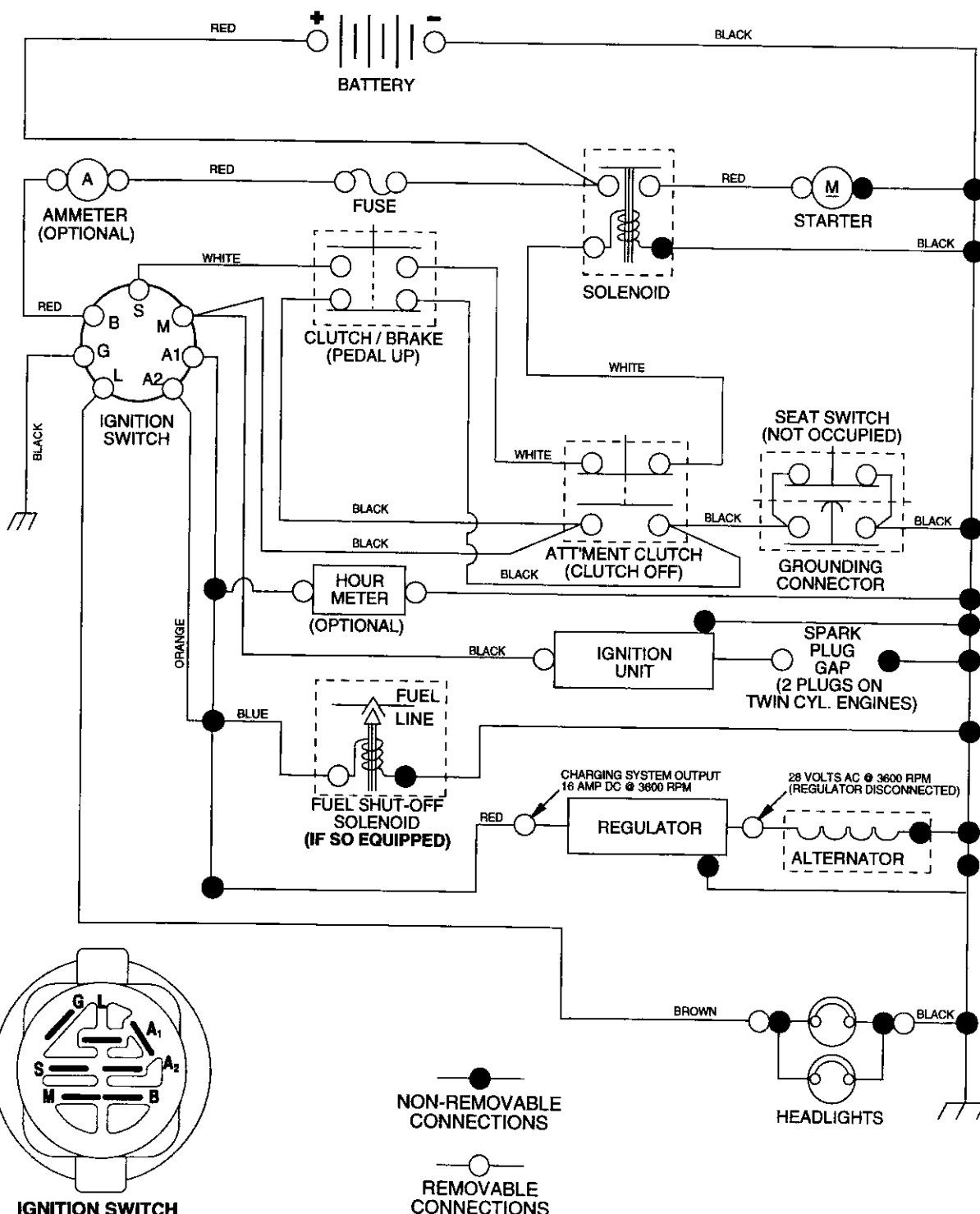

IGNITION SWITCH

POSITION	CIRCUIT	"MAKE"
OFF	M+G+A1	NONE
RUN/LIGHT	B+A1	A2+L
RUN	B+A1	NONE
START	B + S + A1	NONE

●
NON-REMOVABLE CONNECTIONS

○
REMOVABLE CONNECTIONS

WIRING INSULATED CLIPS

NOTE: IF WIRING INSULATED CLIPS WERE REMOVED FOR SERVICING OF UNIT, THEY SHOULD BE REPLACED TO PROPERLY SECURE YOUR WIRING.

REPAIR PARTS

TRACTOR- -MODEL NO. 917. 277440

ELECTRICAL

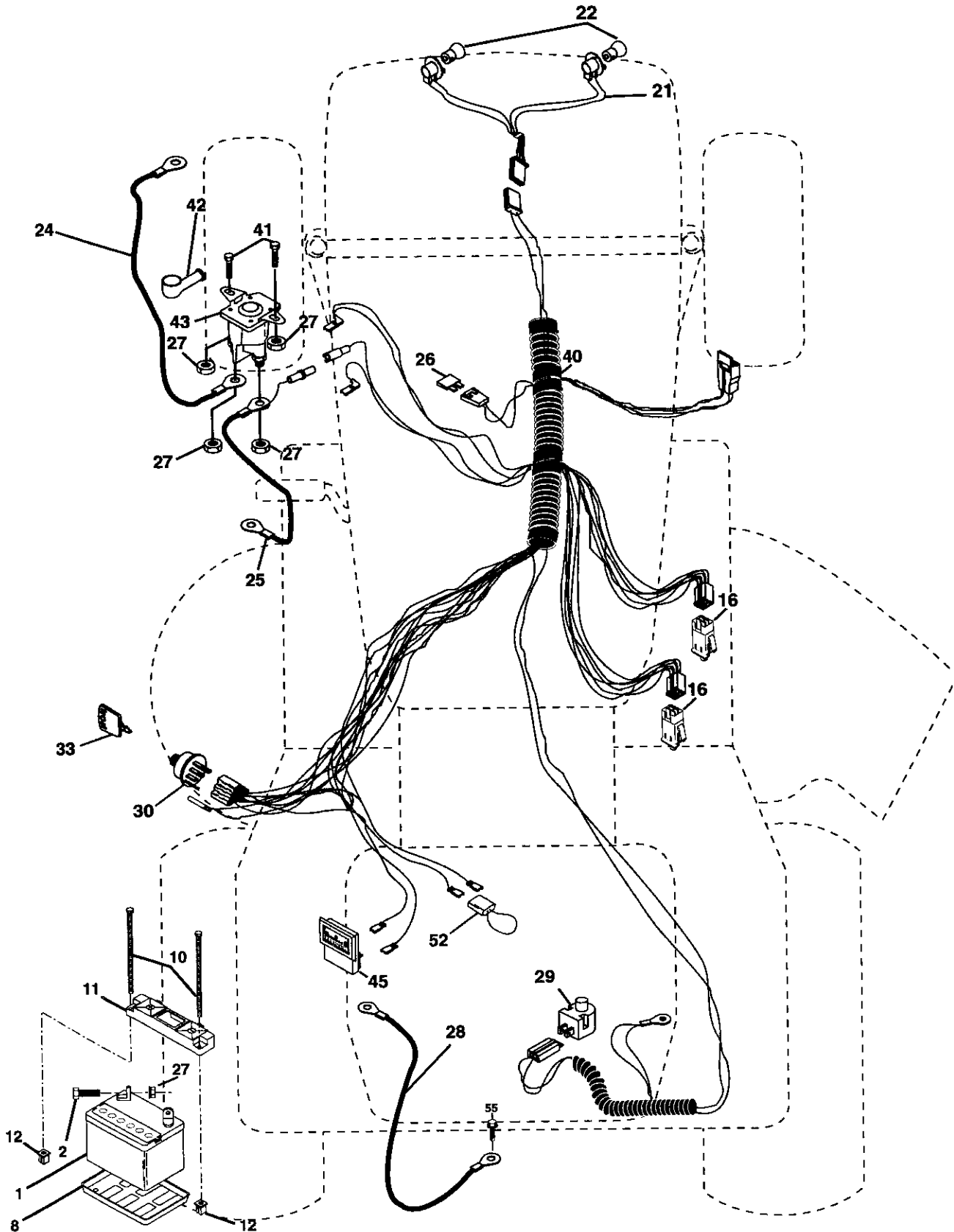

REPAIR PARTS

TRACTOR- -MODEL NO. 917. 277440

ELECTRICAL

KEY NO.	PART NO.	DESCRIPTION
1	144927	Battery
2	74760412	Bolt, Hex 1/4-20 x 3/4
8	7603J	Tray, Battery
10	145211	Bolt, Btr Front 1/4-20 x 7-1/2
11	150109	Holddown Battery Front Mount
12	145769	Nut, Push Nylon Battery Front 1/4
16	176138	Switch Interlock
21	183759	Harness, Light Socket (w/4152J)
22	4152J	Light Bulb
24	4799J	Cable, Battery
25	146148	Cable, Battery
26	175158	Fuse
27	73510400	Nut Keps Hex 1/4-20 unc
28	145491	Cable, Ground
29	121305X	Switch, Seat NC Gray
30	175566	Switch, Ignition
33	140403	Key, Molded
40	179720	Harness, Ignition
41	71110408	Bolt Blk Fin Hex 1/4-20 unc x 1/2
42	131563	Cover, Terminal
43	178861	Solenoid
45	122822X	Ammeter
52	141940	Protection Wire Loop (Hour Meter)
55	17490508	Screw Thdrol 5/16-18 x 1/2

NOTE: All component dimensions give in U.S. inches
1 inch = 25.4 mm

REPAIR PARTS

TRACTOR- -MODEL NO. 917. 277440

CHASSIS AND ENCLOSURES

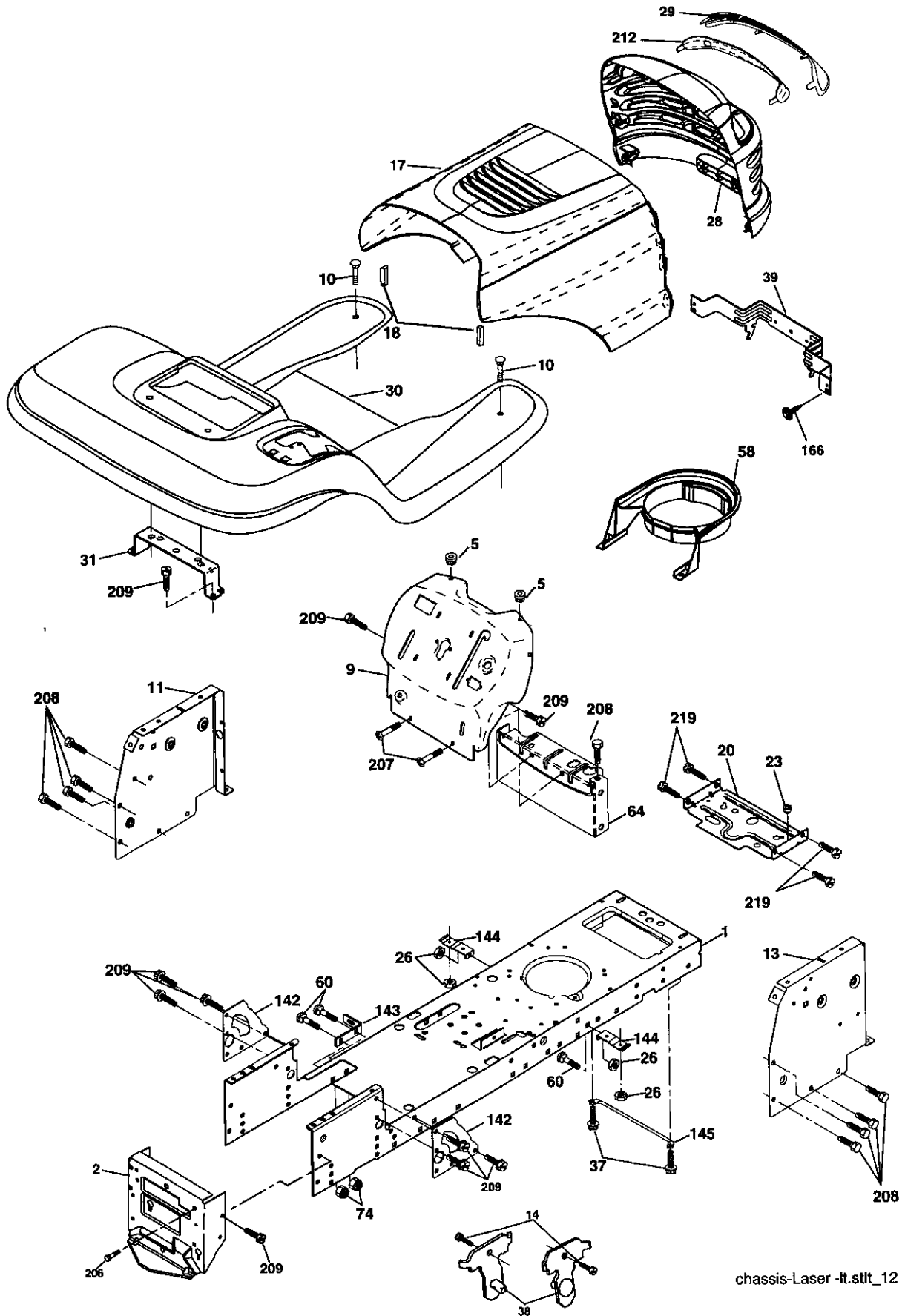

chassis-Laser -lt.stlt_12

REPAIR PARTS

TRACTOR- -MODEL NO. 917. 277440

CHASSIS AND ENCLOSURES

KEY NO.	PART NO.	DESCRIPTION
1	174619	Chassis
2	176554	Drawbar
5	155272	Bumper Hood/Dash
9	168337X014	Dash
10	STD533710	Bolt, Carriage 3/8-16 x 1
11	174996	Panel, Dash, LH
13	172105X010	Panel, Dash, RH
14	17490608	Screw Thdrol 3/8-16 x 1/2
17	185682X613	Hood Assembly
18	184921	Bumper Hood
20	180679	Plate Mtg Battery Fuel Tank
23	124028X	Bushing, Snap, Nylon, Fuel Line
26	STD541437	Locknut, Hex, with Insert 3/8-16 unc
28	190380	Grille/Lens Asm. (Includes Key Nos. 29 & 212)
29	174332X599	Lens, Grille
30	174738X558	Fender/Footrest
31	139976	Bracket, Fender/Support
37	17490508	Screw, Thdrol. 5/16-18 x 1/2 TYT
38	175710	Bracket Asm Pivot Mower Rear
39	174714	Bracket Pivot Laser Lt
58	184462	Air Duct
60	72140606	Bolt Rdhd Sqnk 3/8-16 unc x 3/4
64	154798	Dash Lower STLT
74	STD541437	Nut Crownlock 3/8-16 unc
142	175702	Plate Reinforcement STLT
143	186689	Bracket Swaybar Chassis
144	175582	Bracket Footrest STLT
145	156524	Rod Pivot Chassis/Hood
166	171875	Screw HwHd Hi Low #13-16 x 5/8
206	170165	Bolt Shoulder 5/16-18TT
207	17670508	Screw Thdrol 5/16-18 x 1/2
208	17670608	Screw Thdrol 3/8-16 x 1/2
209	17000612	Screw Hex Wsh Thdrol 3/8-16 x 3/4
212	175143	Insert, Lens
219	17000512	Screw 5/16-18 x 3/4
--	5479J	Plug Button

NOTE: All component dimensions give in U.S. inches
1 inch = 25.4 mm

REPAIR PARTS

TRACTOR- -MODEL NO. 917. 277440

DRIVE

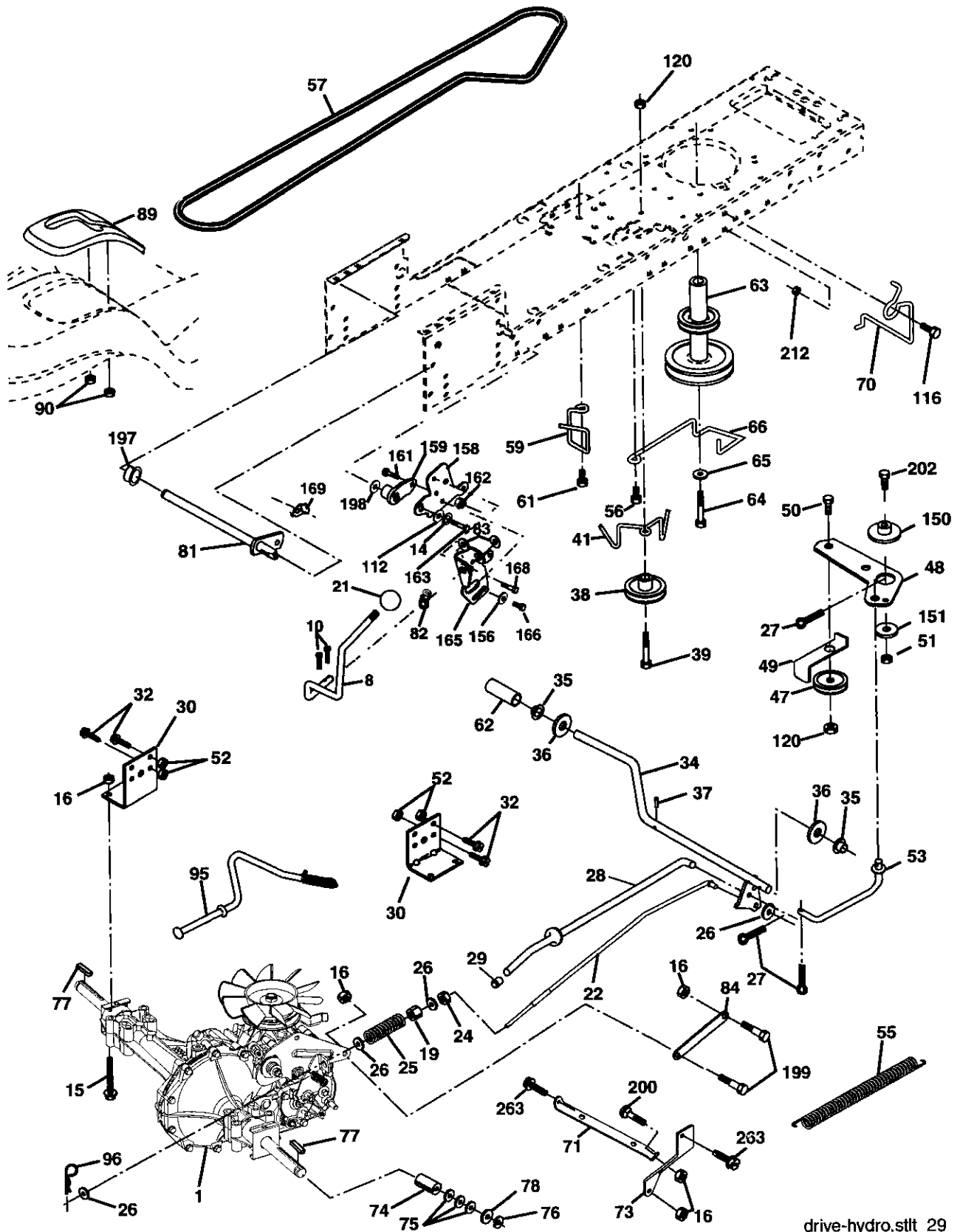

drive-hydro.stlt_29

REPAIR PARTS

TRACTOR- -MODEL NO. 917. 277440

DRIVE

KEY NO.	PART NO.	DESCRIPTION	KEY NO.	PART NO.	DESCRIPTION
1	-----	Transaxle (See Breakdown)	70	180218	Keeper Belt Engine
		Hydro Gr 314-0510	71	169183	Strap Torque Lh Hydro
8	165866	Rod Shift Fender Adjust	73	169182	Strap Torque Rh Hydro
10	STD561210	Pin Cotter 1/8 x 1 CAD	74	137057	Spacer
14	10040400	Washer Lock Hvy Helical	75	121749X	Washer 25/32 x 1-1/4 x 16 Ga.
15	74490544	Bolt Hex FLGHD 5/16-18 x Gr. 5	76	STD581075	E-Ring
16	STD541431	Nut Lock Hex W/Ins. 5/16-18 unc	77	123583X	Key, Square
19	STD541437	Nut Lock Hex W/Wsh 3/8-16 unc	78	121748X	Washer 25/32 x 1-5/8 x 16 Ga.
21	130564	Knob, Deluxe 1/2-13	81	165596	Shaft Asm Cross Tapered
22	169498	Rod, Brake Hydro	82	165711	Spring Torsion
24	73350600	Nut, Hex Jam 3/8-16 unc	83	19171216	Washer 17/32 x 3/4 x 16 Ga.
25	106888X	Spring, Brake Rod	84	169594	Link Transaxle
26	STD551037	Washer 13/32 x 13/16 Ga.	89	164890X428	Console, Shift
27	STD561210	Pin Cotter 1/8 x 3/4 CAD.	90	124346X	Nut Self-Thd Wsh-hd 1/4 Zinc
28	175765	Rod, Parking Brake	95	170201	Control Bypass Hydro 20" Tires
29	71673	Cap, Parking Brake	96	4497H	Retainer Spring 1" Zinc/Cad
30	169592	Bracket, Transaxle	112	19091210	Washer 9/32 x 3/4 x 10 Ga.
32	74760512	Bolt Hex Hd 5/16-18 unc x 3/4	116	72140608	Bolt Rdhd Sqneck 3/8-16 x 1.25
34	175578	Shaft, Foot Pedal	120	73900600	Nut Lock Flg 3/8-16
35	120183X	Bearing, Nylon	150	175456	Spacer Retainer
36	19211616	Washer	151	19133210	Washer 13/32 x 2 x 10 Ga.
37	1572H	Pin, Roll	156	166002	Washer Srtd 5/16 ID x 1.125
38	179114	Pulley, Composite, Flat	158	165589	Bracket Shift Mount
39	72110622	Bolt 3/8-16 x 2-3/4 Gr. 5	159	183900	Hub Shift
41	175556	Keeper, Belt Idler	161	72140406	Bolt Rdhd Sqnk 1/4-20 x 3/4 Gr. 5
47	127783	Pulley, Idler, V-Groove	162	73680400	Nut Crownlock 1/4-20 unc
48	154407	Bellcrank, Clutch	163	74780416	Bolt Hex Fin 1/4-20 unc x 1 Gr. 5
49	123205X	Retainer, Belt	165	165623	Bracket Pivot Lever
50	72110612	Bolt Carr Sh 3/8-16 x 1-1/2	166	17490510	Screw 5/16-18 x 5/8
51	STD541437	Nut Crownlock 3/8-16 unc	168	165492	Bolt Shoulder 5/16-18 x .561
52	STD541431	Nut, Crownlock 5/16-18 unc	169	165580	Plate Fastening
53	105710X	Link, Clutch	197	169613	Nyliner Snap-In 5/8"ID
55	105709X	Spring, Return, Clutch	198	169593	Washer Nyl 7/8 ID x .105" Hyd
56	17060620	Screw 3/8-16 x 1.04	199	169612	Bolt Shoulder 5/16-18 unc
57	140294	V-Belt	200	72140508	Bolt Rdhd Sgnk 5/16-18 unc x 1
59	169691	Keeper, Center Span	202	72110614	Bolt Carr Sh 3/8-16 x 1-3/4 Gr.5
61	17120614	Screw . 3/8-16 x .875	212	145212	Nut Hex Flg. Lock
62	8883R	Cover, Pedal	263	17000612	Screw 3/8-16 x .75
63	180219	Pulley, Engine			
64	173937	Bolt Hex 7/16-20 x 4 Gr. 5			
65	STD551143	Washer			
66	154778	Keeper Belt Engine Hydro			

NOTE: All component dimensions give in U.S. inches
1 inch = 25.4 mm

REPAIR PARTS

TRACTOR- -MODEL NO. 917. 277440

STEERING ASSEMBLY

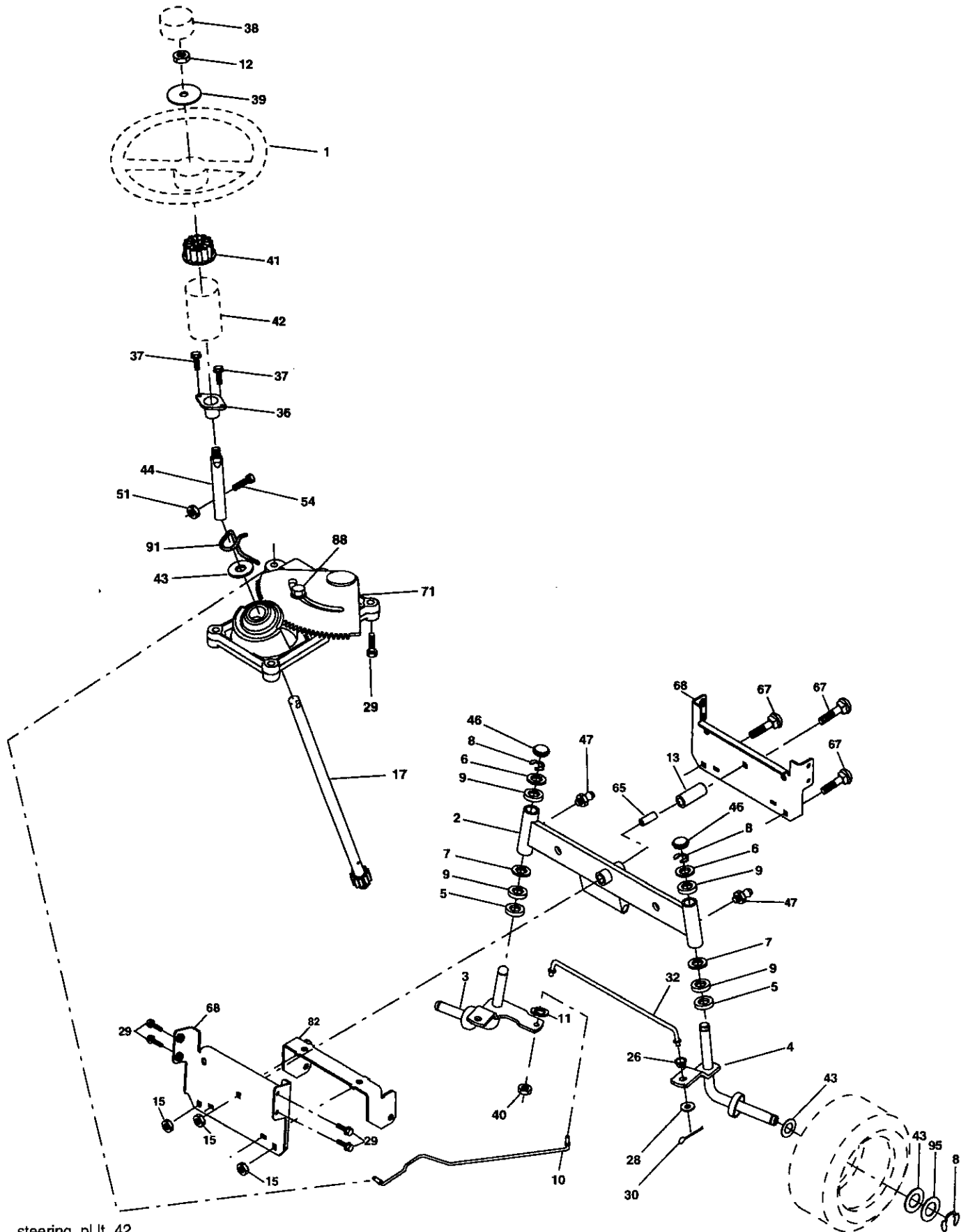

steering_pl.lt_42

REPAIR PARTS

TRACTOR- -MODEL NO. 917. 277440

STEERING ASSEMBLY

KEY NO.	PART NO.	DESCRIPTION
1	139768	Steering Wheel
2	175131	Front Axle Assembly
3	169840	Spindle Assembly, L.H.
4	169839	Spindle Assembly, R.H.
5	6266H	Bearing, Race, Thrust, Hardened
6	121748X	Washer 25/32 x 1-5/8 x 16 Ga.
7	19272016	Washer 27/32 x 1-1/4 x 16 Ga.
8	12000029	Ring, Klip
9	3366R	Bearing, Steering Column
10	175121	Link, Drag
11	STD551137	Washer, Lock
12	73940800	Nut Hex Jam Toplock 1/2-20 unf
13	136518	Spacer, Bearing, Front Axle
15	145212	Nut, Hexflange Lock
17	180641	Shaft Assembly, Steering
26	126847X	Bushing Link Drag
28	19131416	Washer 13/32 x 7/8 x 16 Ga.
29	17000612	Screw 3/8-16 x 3/4
30	STD561210	Pin
32	130465	Rod, Tie
36	155099	Bushing, Steering
37	152927	Screw TT #10-32 x 5 x 3/8 Flange
38	139769	Insert, Steering Wheel
39	19183812	Washer 9/16 x 2-3/8 x 12 Ga.
40	73540600	Lock Nut 3/8-24 unf
41	186737	Adaptor, Steering Wheel
42	145054X428	Boot, Steering Dash P/L Mtl Bk
43	121749X	Washer 25/32 x 1-1/4 x 16 Ga.
44	180640	Extension Steering
46	121232X	Cap, Spindle
47	183226	Fitting, Grease
51	73540400	Nut Crownlock 1/4-28
54	71130420	Bolt Hex 1/4-28 x 1 1/4
65	160367	Spacer Brace Axle
67	72110618	Bolt Rhnd Sq 3/8-16 x 2-1/4
68	169827	Brace Axle
71	175146	Steering Asm
82	169835	Bracket Susp Chassis Front
88	175118	Bolt Shoulder 7/16-20
91	175553	Clip Steering
95	188967	Washer Hardened

NOTE: All component dimensions given in U.S. inches
1 inch = 25.4 mm

REPAIR PARTS

TRACTOR- -MODEL NO. 917. 277440

SEAT ASSEMBLY

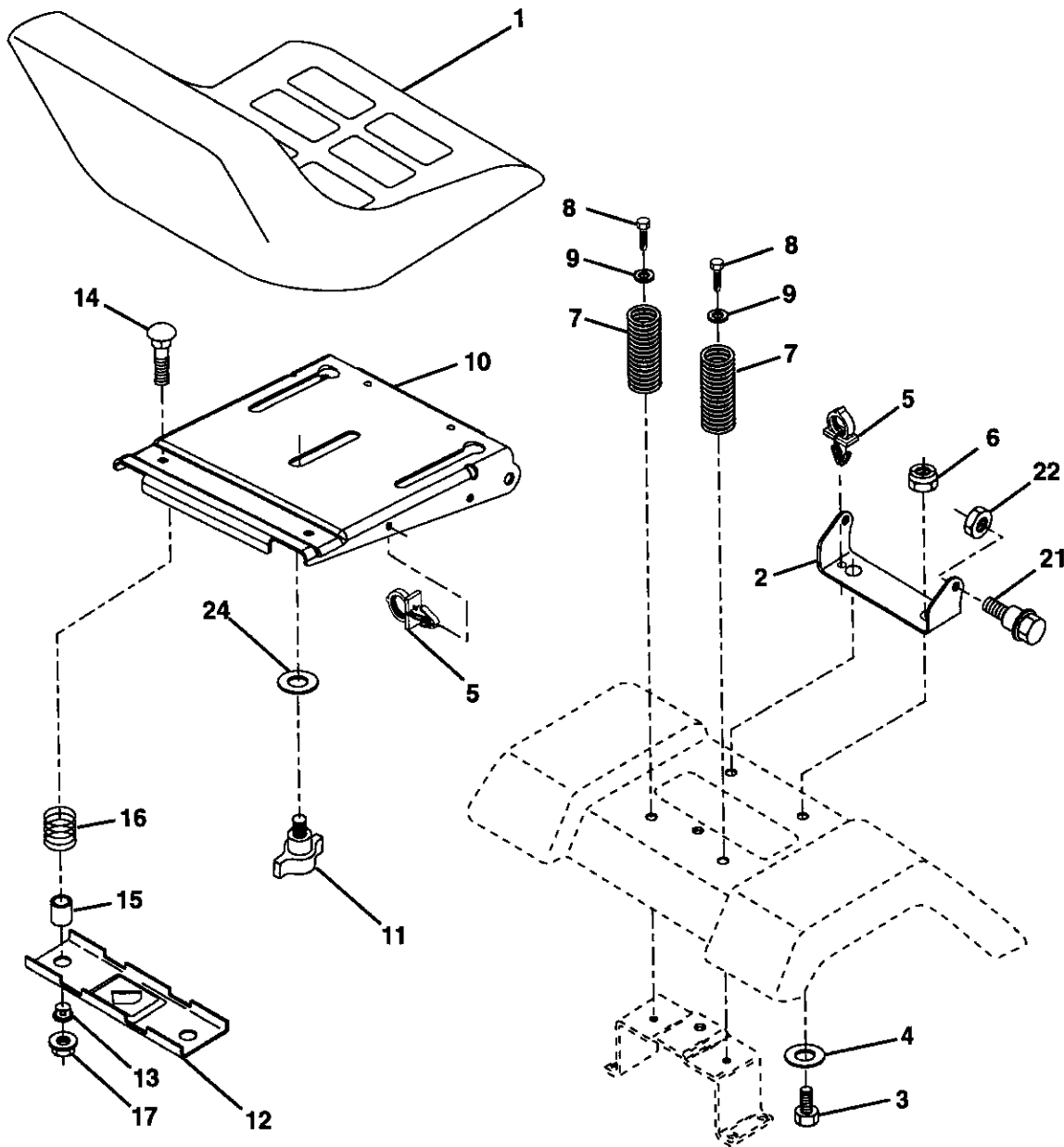

seat_lt.knob_9

KEY NO.	PART NO.	DESCRIPTION
1	188716	Seat
2	180166	Bracket Fender
3	71110616	Bolt Fin Hex 3/8-16 unc x 1
4	19131610	Washer 13/32 x 3/4 x 10 Ga.
5	145006	Clip Push In Hinged
6	STD541437	Nut Hex Lock w/Ins 3/8-16 unc
7	124181X	Spring Seat Cprsn 2 250 Blk Zi
8	17000616	Screw 3/8-16 x 1.5 SMGML
9	19131614	Washer 13/32 x 1 x 14 Ga.
10	180186	Pan Seat
11	166369	Knob Seat
12	121246X	Bracket Pnt Mounting Switch

KEY NO.	PART NO.	DESCRIPTION
13	121248X	Bushing Snap Blk Nyl 50 Id
14	72050412	Bolt Rdhd Sht Nk 1/4-20 x 1-1/2
15	134300	Spacer Split 28 x 96 Zinc
16	121250X	Spring Cprsn 1 27 Blk Pnt
17	123976X	Nut Lock 1/4 Lge Flg Gr. 5 Zinc
21	171852	Bolt Shoulder 5/16-18 unc-2A
22	STD541431	Nut Hex Lock w/Ins 5/16-18
24	19171912	Washer 17/32 x 1-3/16 x 12 Ga.

NOTE: All component dimensions given in U.S. inches
1 inch = 25.4 mm

REPAIR PARTS

TRACTOR- -MODEL NO. 917. 277440

DECALS

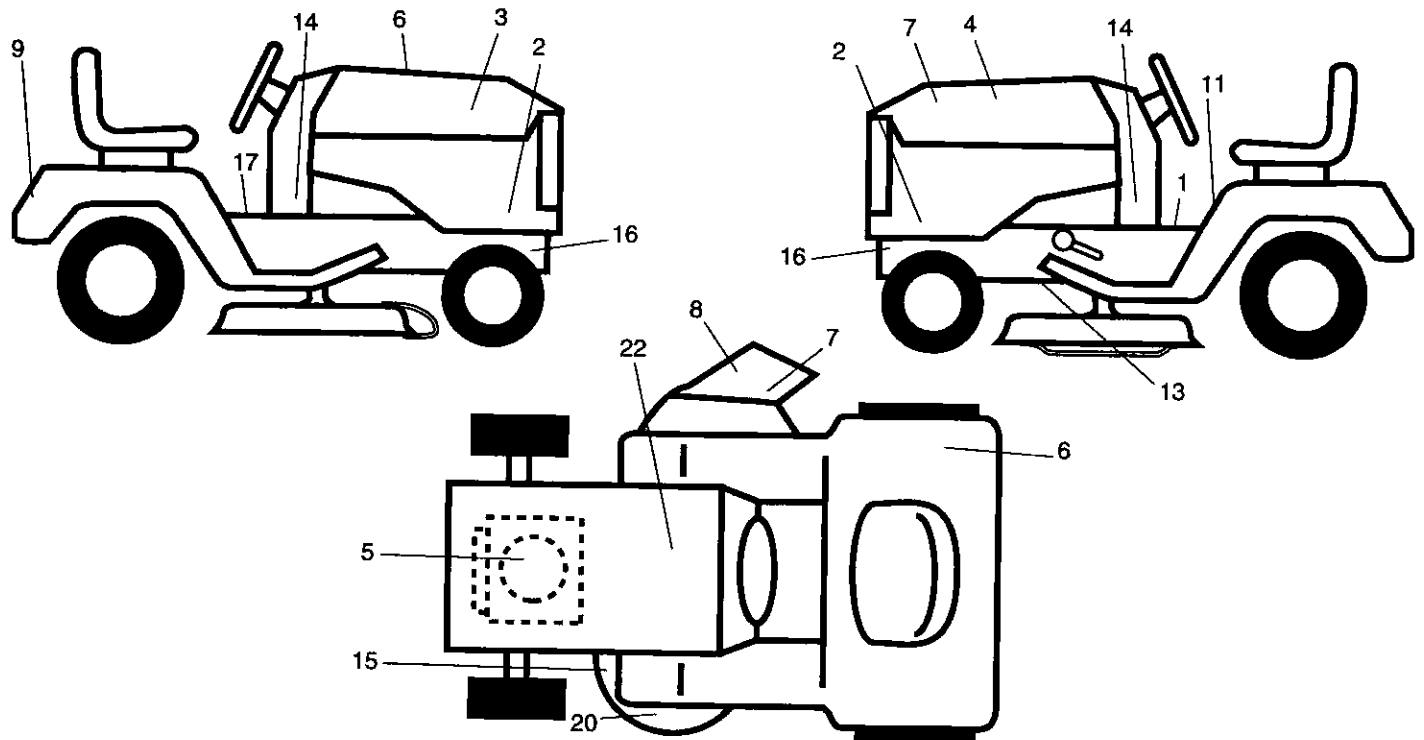

KEY NO.	PART NO.	DESCRIPTION
1	145498	Decal Read Owner's Manual
2	184730	Decal Hood Side
3	184728	Decal Hood Rh
4	184729	Decal Hood Lh
5	189526	Decal Engine H/P
6	180432	Decal Fender DBA
7	182166	Decal Cutfinger
8	179128	Decal Deck
9	184899	Decal Fender
11	159737	Decal Brake/Clutch Symbol
13	146046	Decal V-belt Dr Sch Tractor E
14	189647	Decal Dash Panel

KEY NO.	PART NO.	DESCRIPTION
15	160396	Decal Mower Drive Schematic
16	159736	Decal Hot Muffler
17	140837	Decal Brake Parking Saddle
20	172331	Decal Deck Mower EZ3
22	145005	Decal Battery
--	166960	Decal By Pass Lt Hydro
--	138311	Decal Lift Handle
--	184310X428	Pad Footrest Lh STLT
--	184311X428	Pad Footrest Rh STLT
--	190996	Manual Owner's (Euro)
--	190997	Manual Owner's (Scand)
--	191035	Manual Parts

WHEELS & TIRES

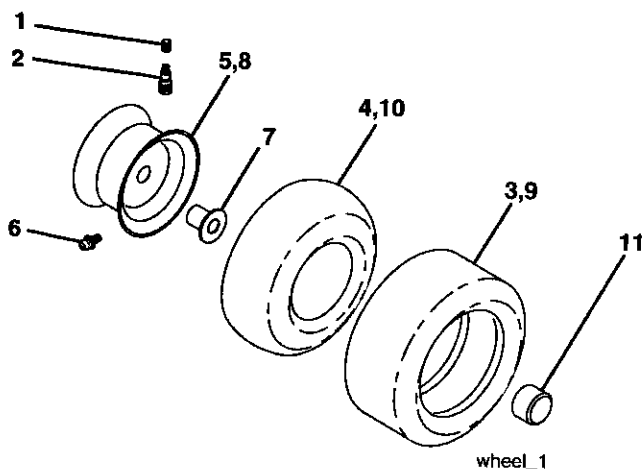

KEY NO.	PART NO.	DESCRIPTION
1	59192	Valve Cap, Tire
2	65139	Stem, Valve
3	106222X	Tire, Front
4	59904	Tube, Front Tire (Not Provided, Service Item Only)
5	106732X624	Rim, Front
6	278H	Fitting, Grease (Front Wheel Only)
7	9040H	Bearing, Flange (Front Wheel Only)
8	106108X624	Rim, Rear
9	122082X	Tire, Rear
10	7152J	Tube, Rear Tire (Not Provided, Service Item Only)
11	104757X428	Cap, Axle
--	144334	Sealant, Tire (10 oz. Tube)

NOTE: All component dimensions given in U.S. inches
1 inch = 25.4 mm

REPAIR PARTS

TRACTOR- -MODEL NO. 917. 277440

ENGINE

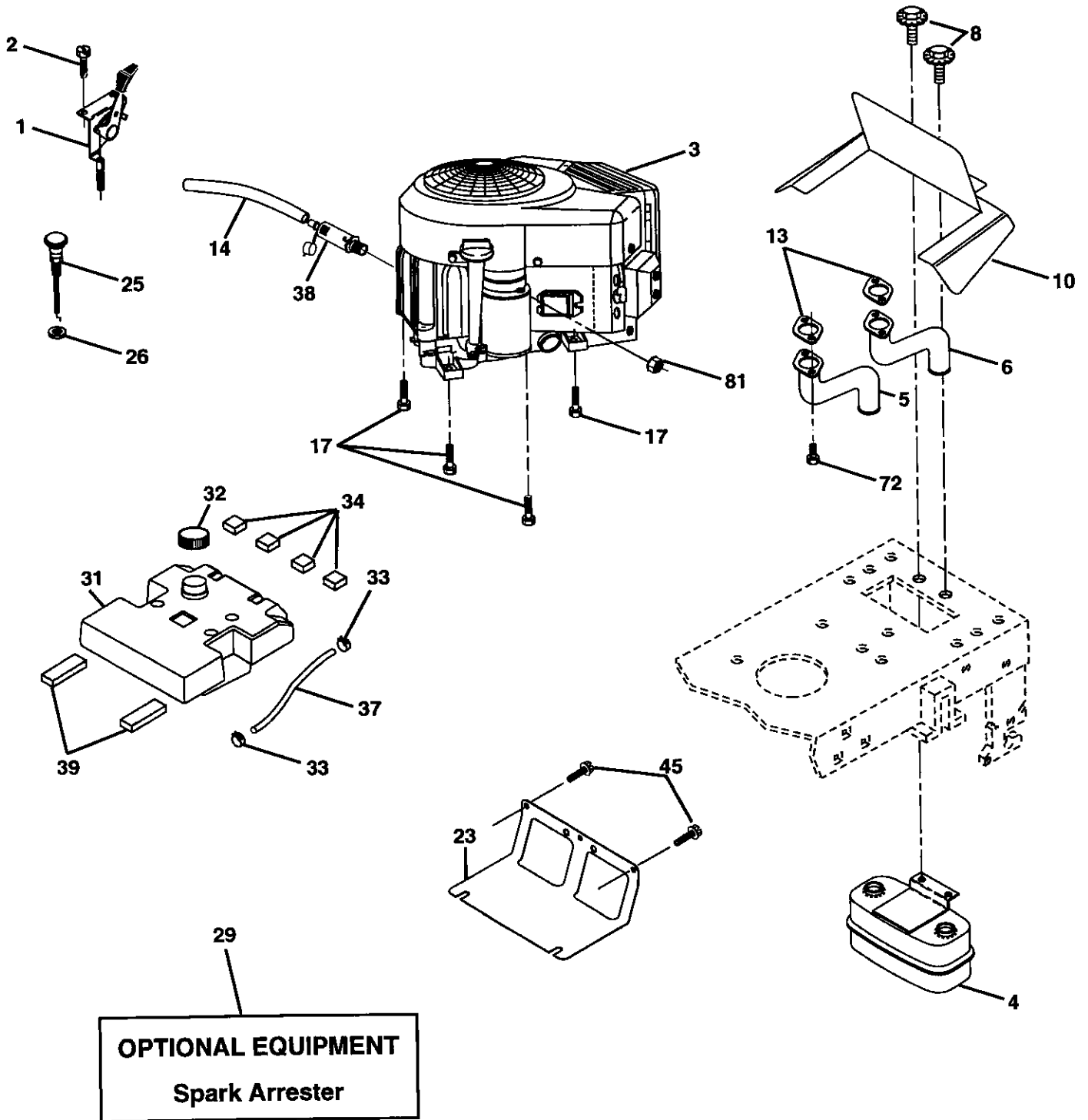

engine-bs intek-twin_28

REPAIR PARTS

TRACTOR- -MODEL NO. 917. 277440

ENGINE

KEY NO.	PART NO.	DESCRIPTION
1	170546	Control Throttle Paddle
2	17720408	Screw Hex Thd Cut 1/4-20 x 5/8 T
3	-----	Engine (See Breakdown) Briggs Model No. 407577-0288-E1
4	149723	Muffler Exhaust
5	159955	Exhaust Asm. Left
6	160589	Exhaust Asm. Right
8	171877	Bolt 5/16 - 18 unc x 3/4 W/Sems
10	162797	Heat Shield Lt
13	165391	Gasket Muffler
14	148456	Tube, Drain Oil Easy
17	17060624	Screw 3/8-16 x 1-1/2 Tytt
23	169837	Shield Browning/Debris Guard
25	145996	Control Choke
26	73920600	Nut Keps 3/8-24 unf
29	137180	Arrestor Spark
31	157103	Tank Fuel 3 50 Rear
32	161696	Cap Fuel
33	123487X	Clamp Hose Blk
34	106082X	Spacer Pad
37	8543R	Line Fuel
38	181654	Plug, Drain Oil Easy
39	109227X	Pad Idler 1.75 x .75 x .06
45	17000612	Screw Hex Wsh Thdrol 3/8-16 x 3/4
72	183906	Screw Socket Head 5/16-18 x 1
81	73510400	Nut, Keps 1/4-20 Starter Nut

NOTE: All component dimensions given in U.S. inches
1 inch = 25.4 mm

REPAIR PARTS

TRACTOR- -MODEL NO. 917. 277440

MOWER LIFT

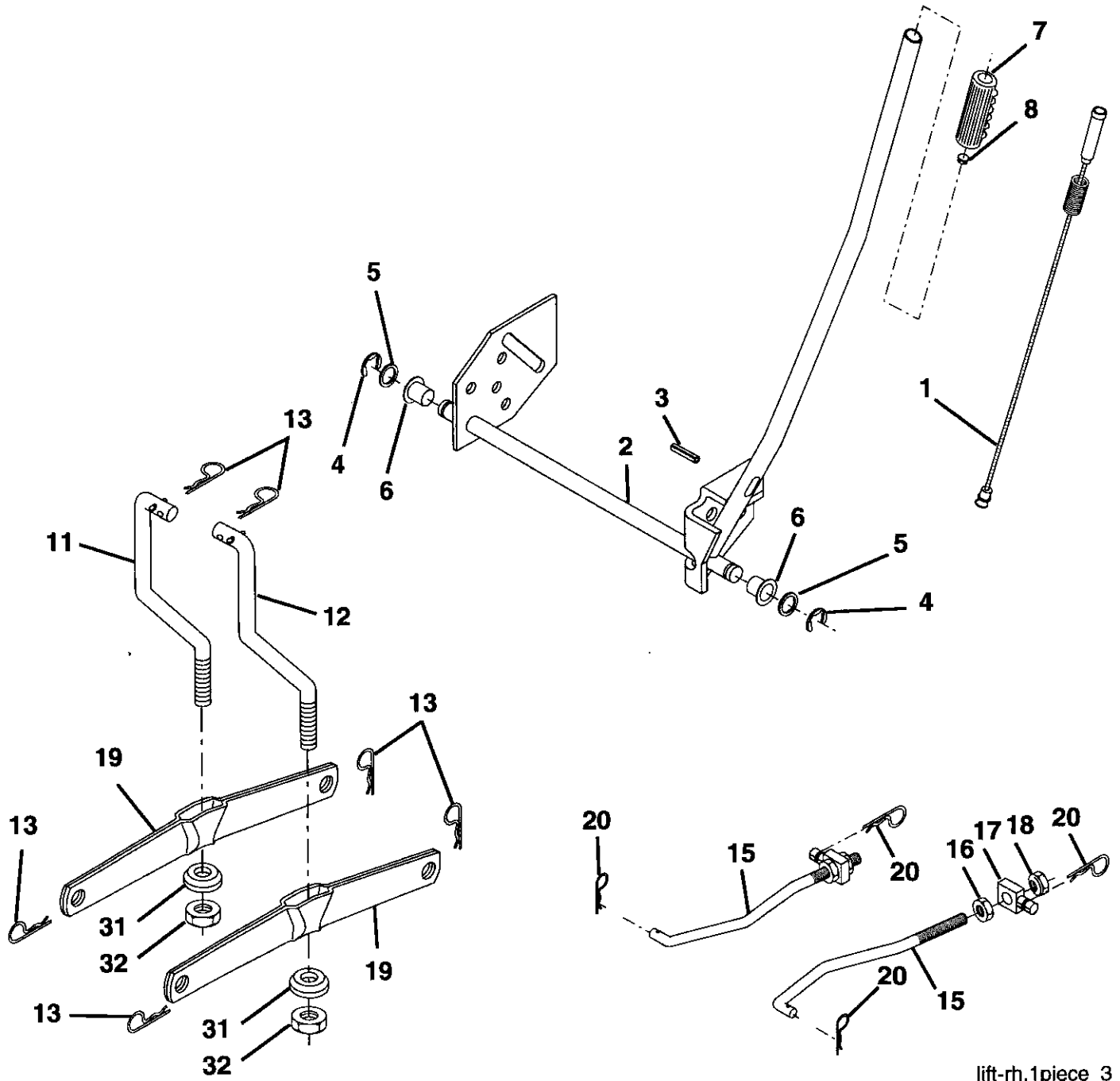

lift-rh.1piece_3

REPAIR PARTS

TRACTOR- -MODEL NO. 917. 277440

MOWER LIFT

KEY NO.	PART NO.	DESCRIPTION
1	159460	Lift Lever Inner Wire Asm.
2	159471	Shaft Asm. Lift
3	105767X	Pin Groove
4	12000002	E Ring
5	19211621	Washer 21/32 x 1 x 21 Ga.
6	120183X	Bearing Nylon
7	125631X	Grip Handle Fluted
8	122365X	Button Plunger Read
11	139865	Link Asm Lift L.H.
12	139866	Link Asm Lift R.H.
13	STD624008	Retainer Spring
15	173288	Link Front
16	73350800	Nut Jam Hex 1/2-13 unc
17	175689	Trunnion
18	73800800	Nut Lock w/Wsh 1/2-13 unc
19	139868	Arm Suspension Mower
20	163552	Retainer Spring
31	169865	Bearing, Pvt. Lift. Tapered
32	73540600	Nut Crownlock 3/8-24

NOTE: All component dimensions given in U.S. inches
1 inch = 25.4 mm

REPAIR PARTS

TRACTOR- -MODEL NO. 917. 277440

MOWER

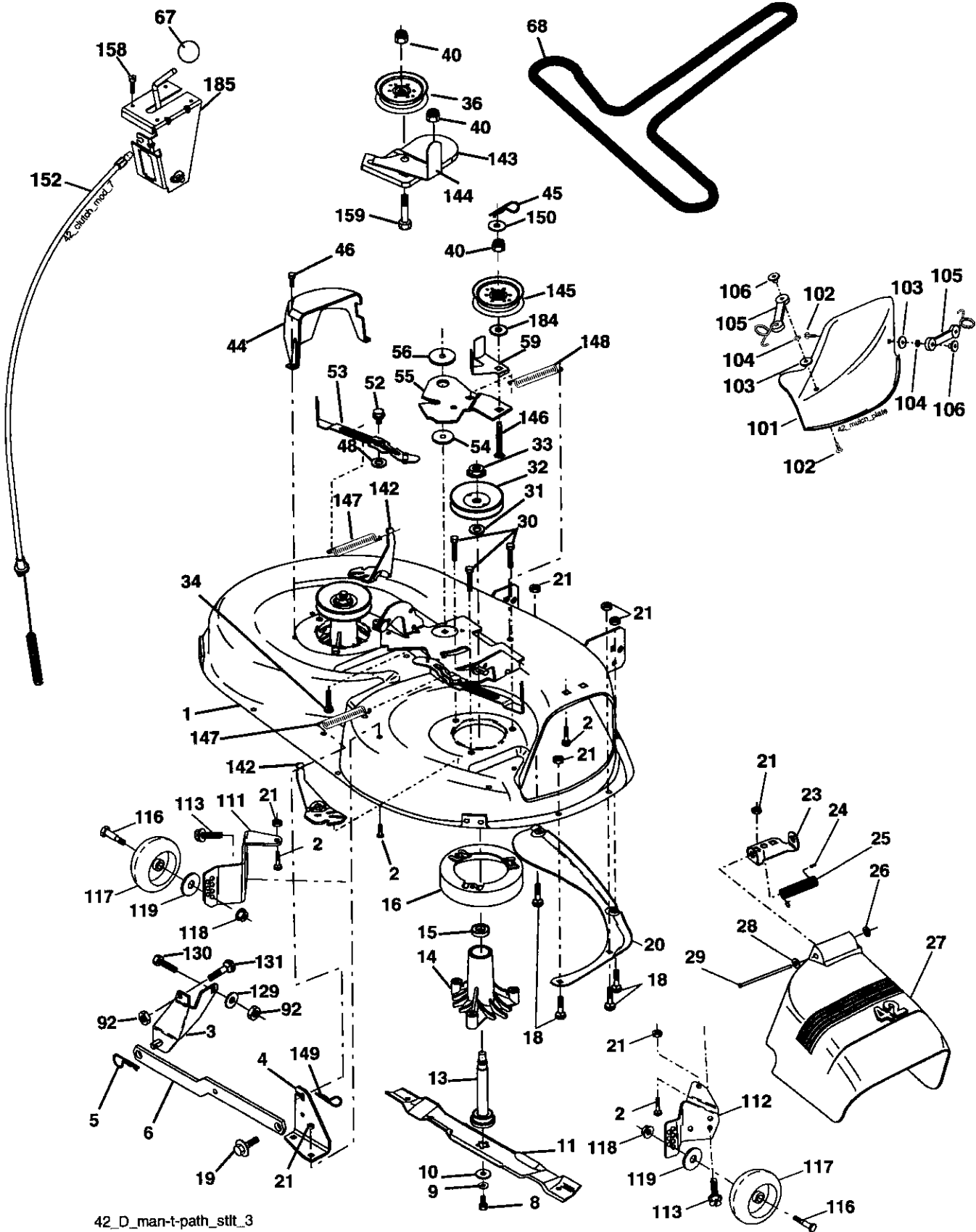

42_D_man-t-path_stlt_3

REPAIR PARTS

TRACTOR- -MODEL NO. 917. 277440

MOWER

KEY NO.	PART NO.	DESCRIPTION	KEY NO.	PART NO.	DESCRIPTION
1	165892	Mower Housing	67	149846	Knob Custom Oval
2	STD533107	Bolt	68	180215	V-Belt
3	138017	Bracket Assembly,Sway Bar, Front	92	STD541437	Locknut, Hex W/Wsh 3/8-16 unc
4	165460	Bracket Sway Bar 38/42"	101	136420	Cover Mulching 42" Black
5	STD624008	Retainer Spring	102	71081010	Screw Truss Hd Phil10-24 x 5/8
6	178024	Bar Sway Deck	103	19061216	Washer #10
8	850857	Bolt, Hex 3/8-24 x 1.25 Gr. 8	104	STD551110	Washer Lock
9	STD551137	Washer, Lock	105	160793	Latch Asm Bagger
10	140296	Washer, Hardened	106	2029J	Nut Weld
11	134149	Blade, 42" Mulching Std	111	179292	Bracket Gauge, Wheel LH
13	137645	Shaft Assembly, Mandrel, Vented (Incl. Key Number 6)	112	179293	Bracket, Gauge, Wheel RH
14	128774	Housing, Mandrel, Vented	113	17000510	Screw 5/16-18
15	110485X	Bearing, Ball, Mandrel	116	4898H	Bolt, Shoulder
16	174493	Stripper, Mower Deck	117	165746	Wheel, Gauge
18	72140505	Bolt, Carriage 5/16-18 x 5/8	118	73930600	Nut, Crownlock 3/8-1
19	132827	Bolt, Shoulder	119	19121414	Washer 13/32 x 7/8 x 14 Ga.
20	159770	Baffle, Vortex	129	19131312	Washer 13/32 x 13/16 x 12 Ga.
21	STD541431	Nut, Crownlock 5/16-18 unc	130	STD523710	Bolt, Fin Hex 3/8-16 unc x 1 Gr. 5
23	177563	Bracket, Deflector	131	STD533710	Bolt Rdhd Sqnk 3/8-16 unc x 1
24	105304X	Cap, Sleeve	142	165890	Arm Spring Brake Mower
25	123713X	Spring, Torsion, Deflector	143	157109	Bracket Arm Idler 42"
26	110452X	Nut, Push	144	158634	Keeper Belt 42" Clutch Cable
27	130968X428	Shield, Deflector	145	165888	Pulley Idler Flat
28	19111016	Washer 11/32 x 5/8 x 16 Ga.	146	171977	Bolt Carraige Idler
29	131491	Rod, Hinge	147	179748	Spring Extension
30	173984	Screw Thdrol Rolling Wsh Hd	148	169022	Spring Return Idler
31	187690	Washer, Spacer	149	165898	Retainer Spring Yellow Zinc
32	153535	Pulley, Mandrel	150	19091210	Washer 9/32 x 3/4 x 10 Ga.
33	178342	Nut, Toplock, Flanged	152	181555	Cable Clutch 42"
34	STD533717	Bolt	158	17720408	Screw Hex Thd Cut 1/4-20 x 5/8
36	131494	Pulley, Idler, Flat	159	STD533717	Bolt Rdhd Sqn 3/8-16 unc x 1-3/4
40	73900600	Nut, Lock 3/8-16 unc	184	19131410	Washer 3/8
44	140088	Guard, Mandrel, L.H.	185	188234	Head Asm. Cable Clutch
45	STD624003	Retainer	--	130794	Mandrel Assembly (Includes housing, shaft and shaft hardware only-pulley not included)
46	137729	Screw, Thd. Roll 1/4-20 x 5/8	--	181281	Replacement Mower , Complete (Std. Deck-Order separately mulcher cover and guage wheel components key nos. 101 - 106 and 116 - 119)
48	133944	Washer, Hardened			
52	139888	Bolt, Shoulder 5/16-18 unc			
53	184907	Arm Assembly, Pad, Brake			
54	178515	Washer, Hardened			
55	155046	Arm, Idler			
56	165723	Spacer, Retainer			
59	141043	Guard, Tuv Idler (94)			

NOTE: All component dimensions given in U.S. inches
1 inch = 25.4 mm

REPAIR PARTS

TRACTOR- -MODEL NO. 917. 277440

HYDRO GEAR TRANSAXLE - MODEL NUMBER 314-0510

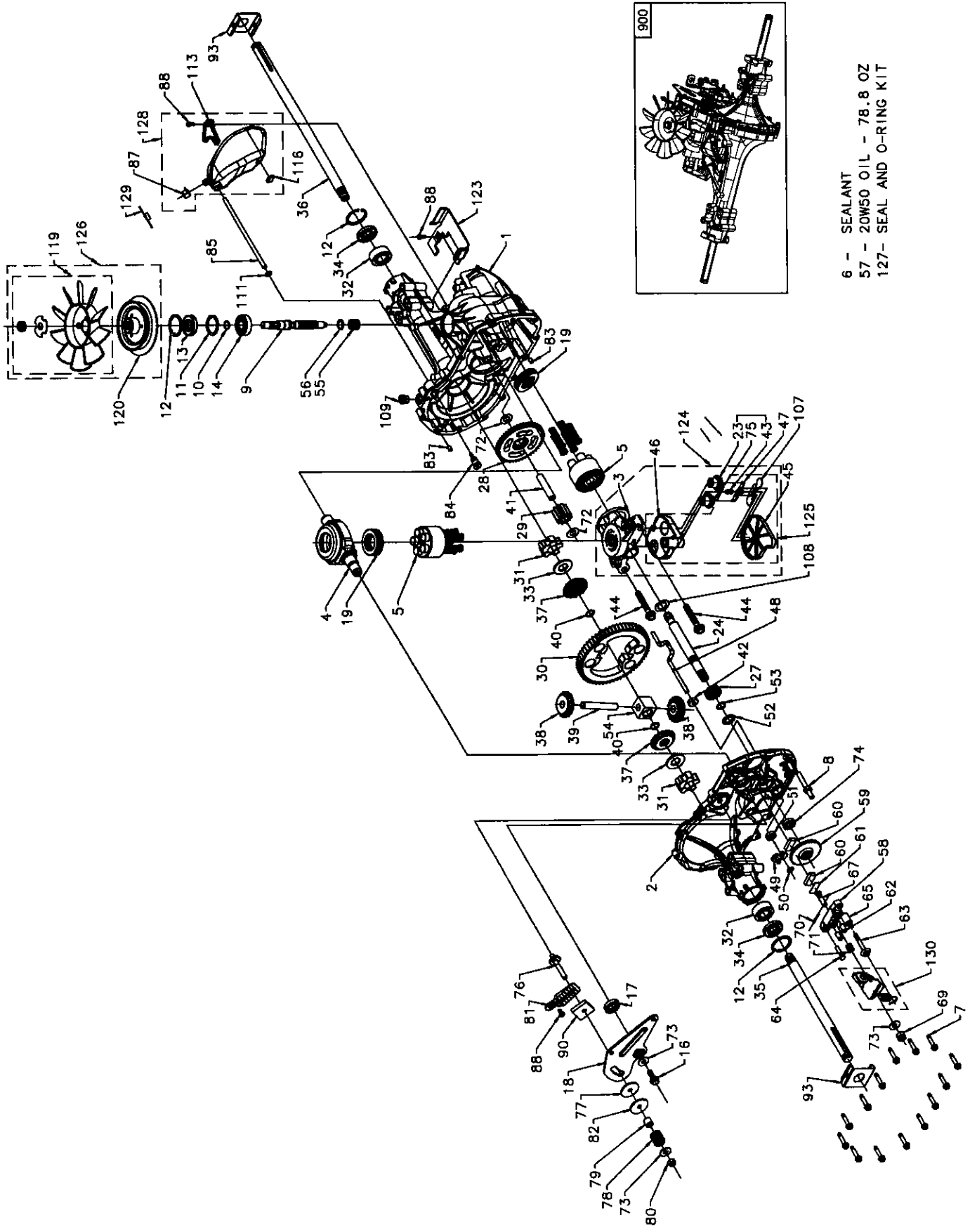

- 6 - SEALANT
- 57 - 20W50 OIL - 78.8 OZ
- 127- SEAL AND O-RING KIT

REPAIR PARTS

TRACTOR- -MODEL NO. 917. 277440

HYDRO GEAR TRANSAXLE - MODEL NUMBER 314-0510

KEY NO.	PART NO.	DESCRIPTION	KEY NO.	PART NO.	DESCRIPTION
1	170351	Kit, Main Housing Main Housing, Machined Bushing .865 X .985 X .790	71	170417	Brake Spring
2	170352	Kit, Side Housing Side Housing, Machined Bushing .865 X .985 X .790	72	170418	Washer (310-0750)
		Bushing .624 X .719 X .562	73	142884	Washer, Flat
3	170353	Kit, Center Section Center Section, Machined Bushing .707 X .788 X .591	74	170419	Seal, Oil
4	170354	Swashplate, Trunnion Machined	75	170420	Ass'y Check Plug
5	169898	Kit, Cylinder Block (10cc) Block - Cylinder Piston Spring, Compression Washer Thrust	76	170421	Bolt, Stud 5/16-24
			77	170422	Puck, Friction
6	178322	Sealant Tube	78	142969	Spring
7	170356	Hexflange Screw 1/4-20 X 1.25	79	142980	Spacer
8	170357	Stud, 5/16-24 Hex Double End	80	150778	Nut, Nylon Insert Hex Lock 5/16-24
9	170358	Shaft, Input	81	170423	Wedge, Friction
10	170359	Retaining Ring	82	170424	Clip, Washer
11	170360	Spacer	83	161168	Pin
12	169870	Retaining Ring	84	170425	Fitting, 5/16 X Sae 5/32 Tube
13	170361	Seal, Lip .67 X 1.58 X .276	85	170426	Hose, Expansion Tank
14	173158	Bearing, Ball 6203 (BDR)	87	173160	Cap, Vent
16	170362	Hex Flange Head Screw 1/4-20 X 1.25	88	178334	Bolt, Self Tapping (BDR)
17	170363	Seal, Lip 18 X 32 X 7	90	170430	Puck, Inner Wedge
18	170364	Arm, Control	93	170431	Spring Clip, Housing
19	173159	Bearing, Thrust (10cc)	107	170432	Deflector
23	170365	Check Plug Assembly	108	170433	Washer, Motor Shaft .71ID X 1.15OD X .03 Thick
24	170366	Shaft Motor	109	170434	Plug, Straight Thread 9/16-18
27	170367	Gear, Pinion, 13t	111	170435	O-ring .7 X .301 ID
28	170368	10t / 48t Gear	113	170437	Bracket, Support Expansion Tank
29	170369	Gear, 10t Jackshaft	119	191031	Kit, Fan - Washer - Nut Fan, 7 In
30	170370	60t Bullgear			Hex Lock Nut 1/2-20 (Nylon Insert)
31	170371	Sleeve Bearing .75 X 1.75 X .625	120	188312	Washer, Or Slotted, .53 X 1.63 X .06
32	170389	Sleeve Bearing (Outboard) .75 X 1.575 X .625	123	178800	Pulley
			124	170444	Belt Keeper
33	142991	Washer			Kit, Center Section Filter Bypass
34	170390	Lip Seal, Axle Shaft			Center Section Machining
35	170391	Shaft, Axle (Keyed, R.h.)			Base Filter W/ Poppet
36	170392	Shaft, Axle (Keyed, L.h.)			Check Plug Assembly, .027 Washer
37	150792	Gear, Splined Diff. (210-1000 & 310-0750)			Check Plug Assembly, Washer
38	150793	Gear, Miter Diff. (210-1000 & 310-0750)			Spring, Bypass
39	150809	Differential Shaft (310-0750)			Actuator, Bypass
40	170393	Retaining Ring	125	170445	Deflector
41	170394	Pin, Jackshaft			Bottom, Filter
42	170395	Magnet, Ring			Bushing, .707 X .788 X .591
43	170396	Spring, Bypass			Kit, Filter
44	150797	Bolt 3/8-24 X 2-1/2			Bottom, Filter
45	170397	Filter			Spring, Bypass
46	170398	Base, Filter			Actuator, Bypass
47	170399	Actuator, Bypass	126	191028	Deflector
48	170400	Rod, Bypass Actuator			Base, Filter W/ Poppet
49	170401	Arm, Bypass			Kit, Fan/pulley
50	170402	Retaining Ring .25 External			Hex Jam 1/20-20 (Nylon Inser)
51	170403	Seal, Lip .741 X .25 X .25			Washer, OD Slotted, .53 X 1.63 X .06
52	170404	Washer, Flat 0.050" (210-1000)	127	170447	Fan, 7 In
53	170405	Retaining Ring			Pulley
54	170406	Bearing, Center Block			Kit, Seal
55	142977	Spring, Helical Compression			Lip Seal .67 X 1.58 X .276
56	142978	Washer, Block Thrust			Lip Seal 18 X 32 X 7
57	---	20W-50 Oil			Lip Seal .706 X 1.584 X .25
58	142929	Kit, Brake Yoke			Lip Seal .741 X .250 X .250 Tc
59	170408	Rotor, Brake			Oil Seal .625 X 1.0 X .25
60	142883	Brake Puck	128	173165	O-ring .07 X .301 ID
61	142882	Brake Puck Plate			Kit, Expansion Tank, Tank, Expansion
62	170409	Pin, Brake Actuating			Cap, Vent Bolt, Self Tapping 10-32 X 1/2
63	170410	Hfhcs 1/4-20 X 2 W/patch, Special Flange	129	191032	Bracket, Support Expansion Tank
64	142892	Bolt, Nylok	130	186352	Silicon Sponge 1/2 X 1/2 X 3/16
65	170411	Spacer, Brake Torsion Spring			Cap, Expansion Tank Shipping
67	170413	Bolt, Square Head - Brake			Kit, Brake Arm And Spring Arm, Brake
69	170415	Nut, Castle 5/16-24			Spring, Brake Arm Bias Instruction Sheet
70	170416	Pin, Cotter 3/32x3/4			

NOTE: All component dimensions given in U.S. inches 1 inch = 25.4 mm

REPAIR PARTS

TRACTOR- -MODEL NO. 917. 277440
BRIGGS & STRATTON ENGINE - - MODEL NUMBER 407577, TYPE NUMBER 0288-E1

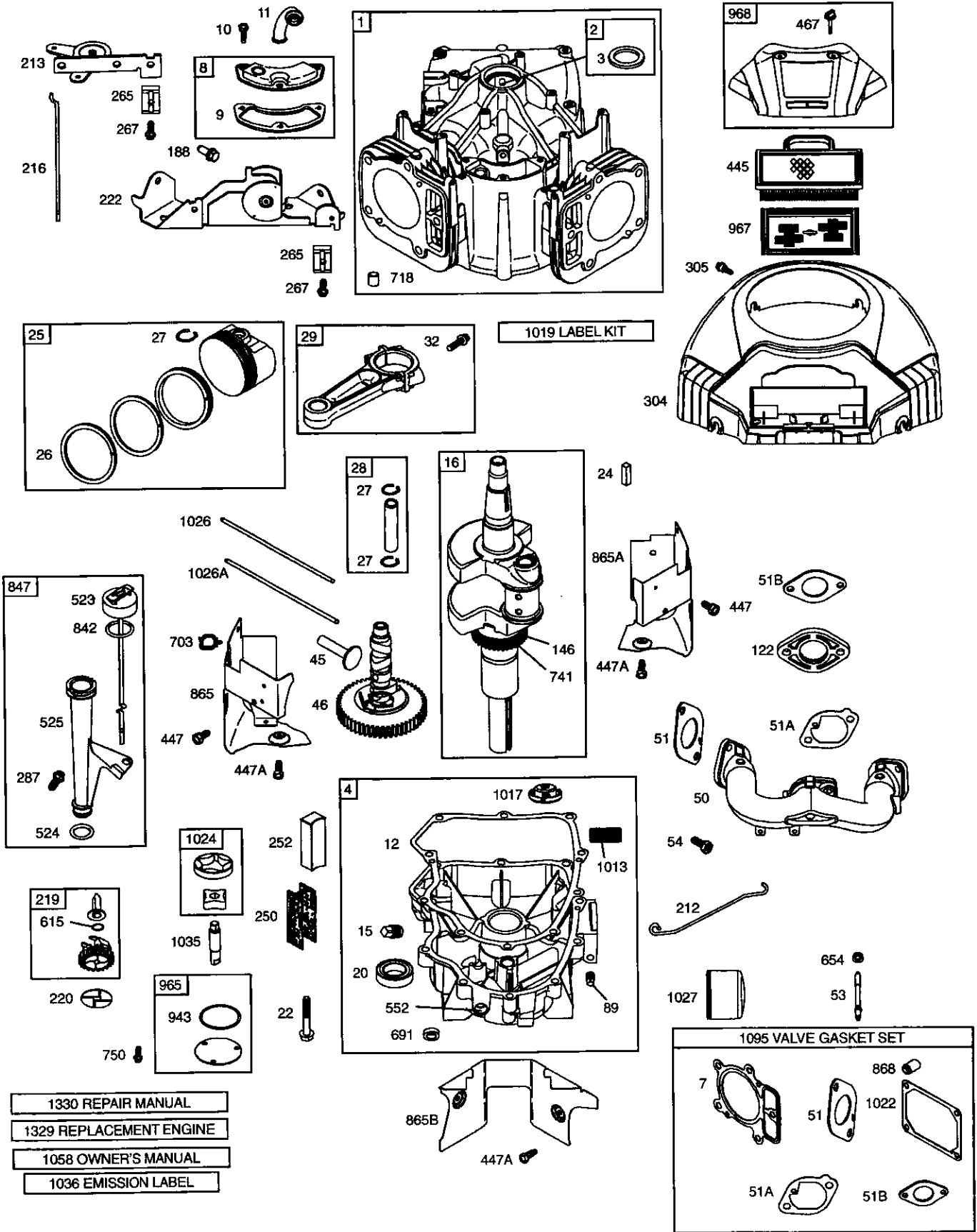

- 1330 REPAIR MANUAL
- 1329 REPLACEMENT ENGINE
- 1058 OWNER'S MANUAL
- 1036 EMISSION LABEL

REPAIR PARTS

TRACTOR--MODEL NO. 917. 277440

BRIGGS & STRATTON ENGINE -- MODEL NUMBER 407577, TYPE NUMBER 0288-E1

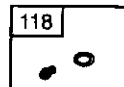
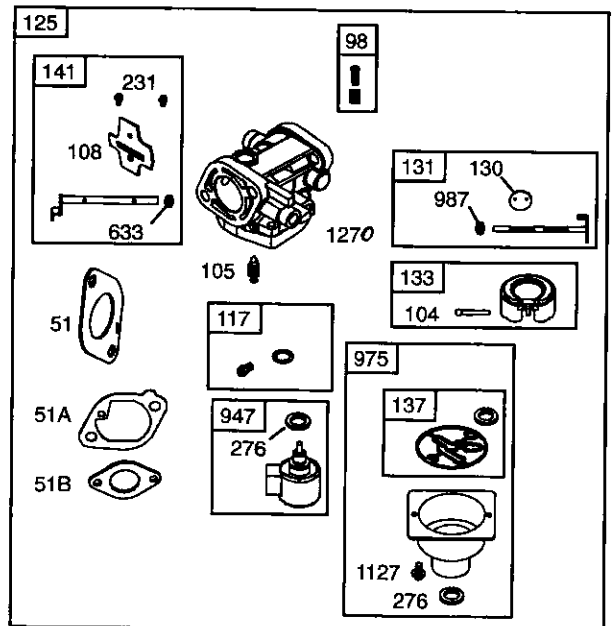
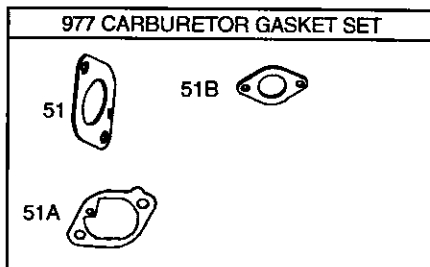
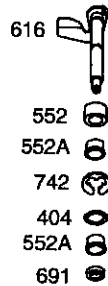
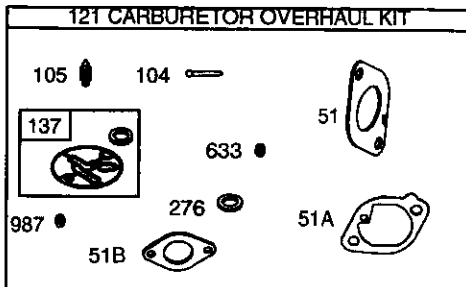
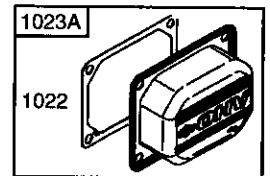
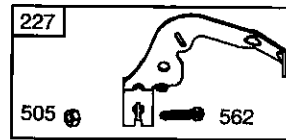
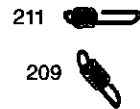
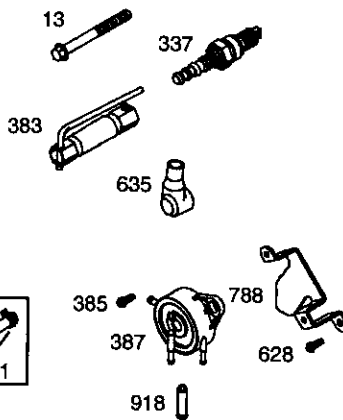
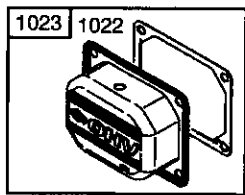
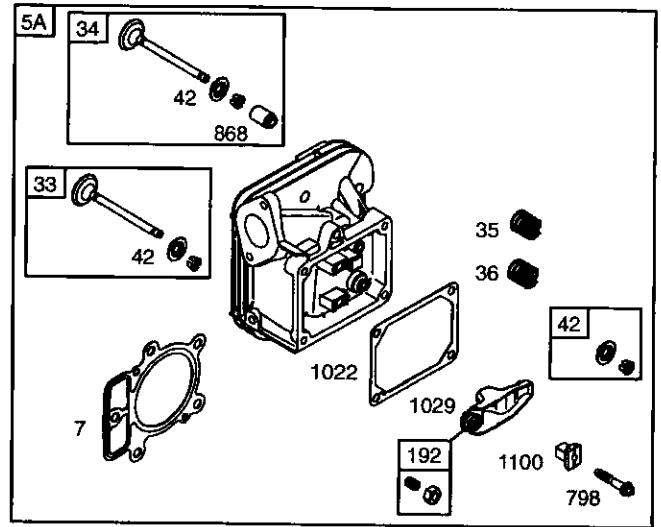
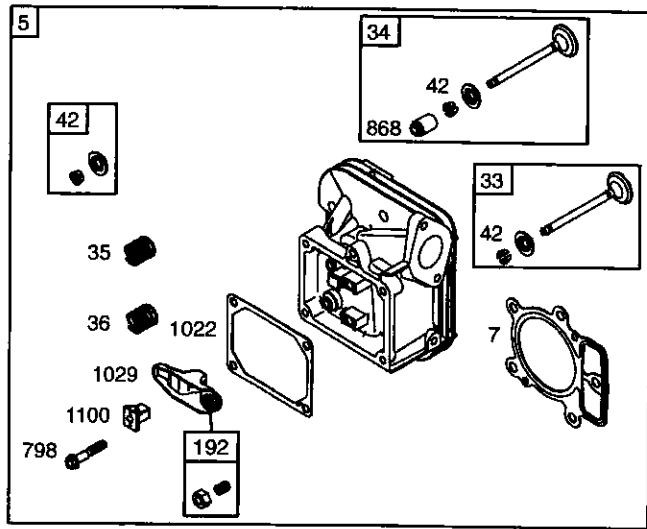

REPAIR PARTS

TRACTOR- -MODEL NO. 917. 277440

BRIGGS & STRATTON ENGINE - - MODEL NUMBER 407577, TYPE NUMBER 0288-E1

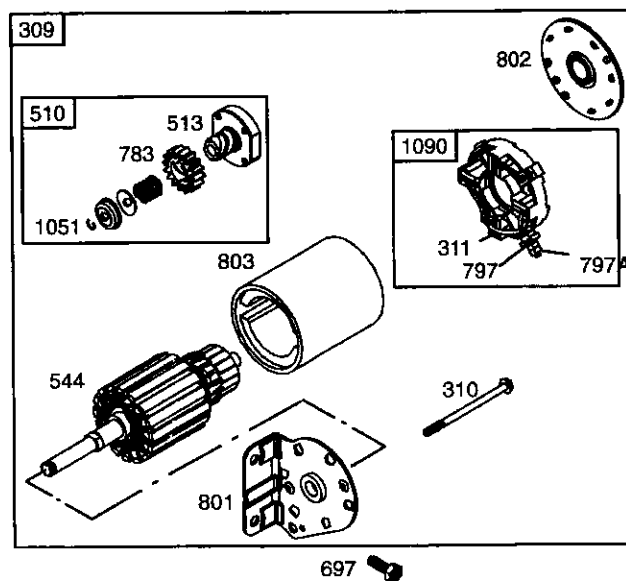
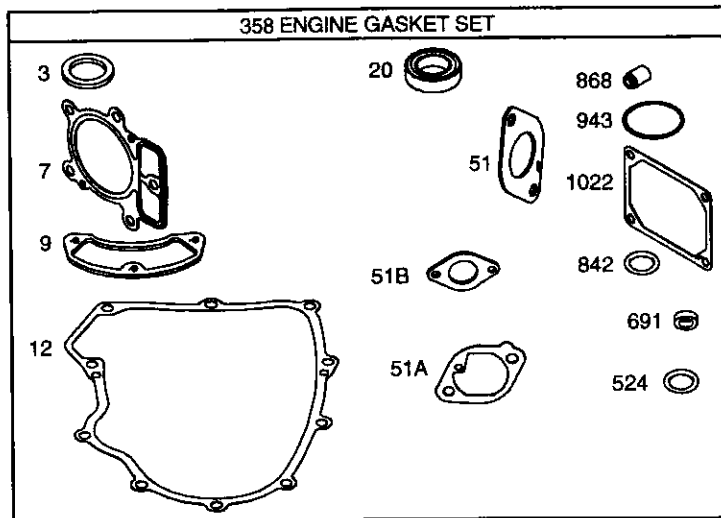
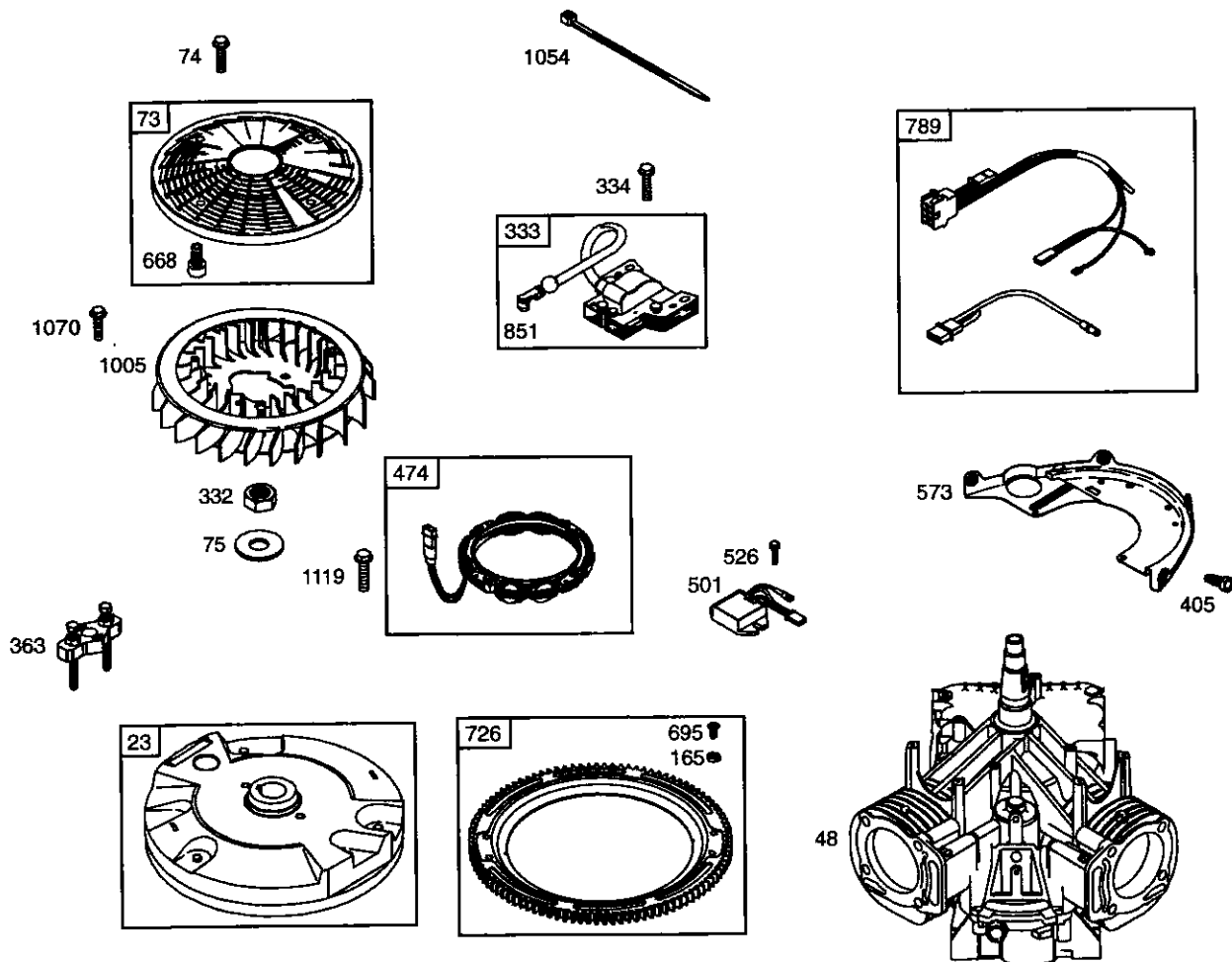

REPAIR PARTS

TRACTOR- -MODEL NO. 917. 277440

BRIGGS & STRATTON ENGINE - - MODEL NUMBER 407577, TYPE NUMBER 0288-E1

KEY NO.	PART NO.	DESCRIPTION	KEY NO.	PART NO.	DESCRIPTION
1	699751	Cylinder Assembly	133	694914	Float-Carburetor
2	499585	Kit-Bushing/Seal (Magneto Side)	137	698781	Ø Gasket-Float Bowl
3	391086	• Seal-Oil (Magneto Side)	141	699811	Kit-Choke Shaft
4	699747	Sump-Engine	146	690979	Key-Timing
5	693998	Head-Cylinder (Cylinder 1)	165	693148	Nut (Ring Gear)
5A	693999	Head-Cylinder (Cylinder 2)	187	699799	Line-Fuel (Cut to Required Length)
7	690962	*+ Gasket-Cylinder Head	187A	691049	Line-Fuel (Molded)
8	499601	Breather Assembly	188	691003	Screw (Control Bracket)
9	690937	• Gasket-Breather	192	690083	Adjuster-Rocker Arm
10	691108	Screw (Breather Assembly)	209	697674	Spring-Governor
11	690942	Tube-Breather	211	691019	Spring-Governed Idle
12	697227	• Gasket-Crankcase	212	699805	Link-Throttle
13	690360	Screw (Cylinder Head)	213	691021	Bracket-Choke Control
15	690946	Plug-Oil Drain	216	691022	Link-Choke
16	691046	Crankshaft	219	698231	Gear-Governor
20	690947	• Seal-Oil (PTO Side)	220	690412	Washer (Governor Lever)
22	694966	Screw (Engine Sump)	222	698757	Bracket-Control
23	691053	Flywheel	227	691048	Lever-Governor Control
24	222698	Key-Flywheel	231	690718	Screw (Choke Valve)
25	499588	Piston Assembly (Standard)	240	691035	Filter-Fuel
25	499590	Piston Assembly (.020" Oversize)	250	690957	Retainer-Breather
26	499604	Ring Set-Piston (Standard)	252	690956	Collector-Oil
26	499606	Ring Set-Piston (.020" Oversize)	265	691024	Clamp-Casing
27	690975	Lock-Piston Pin	267	695134	Screw (Casing Clamp)
28	690229	Pin-Piston	276	695410	Ø Washer-Sealing
29	499583	Rod-Connecting	287	691108	Screw (Dipstick Tube)
32	690976	Screw (Connecting Rod)	304	695277	Housing-Blower
33	499596	Valve-Exhaust	305	691005	Screw (Blower Housing)
34	499597	Valve-Intake	309	497595	Motor-Starter
35	690963	Spring-Valve (Intake)	310	690323	Bolt-Starter Motor
36	690963	Spring-Valve (Exhaust)	311	497608	Brush Set
42	499586	Keeper-Valve	332	691059	Nut (Flywheel)
45	690977	Tappet-Valve	333	691060	Armature-Magneto
46	699748	Camshaft	334	691061	Screw (Magneto Armature)
48	698177	Short Block	337	691043	Spark Plug
50	699801	Manifold-Intake	358	699823	Set-Engine Gasket
51	690949	•Ø‡ Gasket-Intake	363	691062	Flywheel Puller
51A	699800	•Ø‡ Gasket-Intake	383	690966	Wrench-Spark Plug
51B	699803	•Ø‡ Gasket-Intake	385	691108	Screw (Fuel Pump)
53	690951	Stud (Carburetor)	387	808656	Pump-Fuel
54	699816	Screw (Intake Manifold)	404	690442	Washer (Governor Crank)
73	691055	Screen-Rotating	405	697820	Screw (Back Plate)
74	698425	Screw (Rotating Screen)	445	499486	Filter-Air Cleaner Cartridge
75	691056	Washer (Flywheel)	447	691003	Screw (Air Guide Cover)
89	690283	Plug-Oil	447A	691108	Screw (Air Guide Cover)
98	699721	Kit-Idle Speed			
104	694918	Ø Pin-Float Hinge			
105	698537	Ø Valve-Float Needle			
108	699808	Valve-Choke			
117	698784	Ø Jet-Main (Standard)			
118	699820	Jet-Main (High Altitude)			
121	699814	Kit-Carburetor Overhaul			
122	699802	Spacer-Carburetor			
125	699807	Carburetor			
127	698810	Plug-Weich			
130	699809	Valve-Throttle			
131	699812	Kit-Throttle Shaft			

- Included in Engine Gasket Set, Key. No. 358
- Ø Included in Carburetor Overhaul Kit, Key. No. 121
- ‡ Included in Carburetor Gasket Set, Key. No. 977
- + Included in Valve Gasket Set, Key. No. 1095

NOTE: All component dimensions given in U.S. inches 1 inch = 25.4 mm

REPAIR PARTS

TRACTOR- -MODEL NO. 917. 277440

BRIGGS & STRATTON ENGINE - - MODEL NUMBER 407577, TYPE NUMBER 0288-E1

KEY NO.	PART NO.	DESCRIPTION	KEY NO.	PART NO.	DESCRIPTION
467	691008	Knob-Air Cleaner	918	694000	Hose-Vacuum
474	696458	Alternator	943	690589	• Seal-O Ring (Oil Pump Cover)
501	691185	Regulator	965	499613	Cover-Oil Pump
505	691029	Nut (Governor Control Lever)	967	273638	Filter-Pre Cleaner
510	497606	Drive-Starter	968	790095	Cover-Air Cleaner
513	692024	Clutch-Drive	975	699502	Bowl-Float
523	691036	Dipstick	977	699815	Gasket Set-Carburetor
524	691032	• Seal-Dipstick Tube	987	699813	∅ Seal-Throttle Shaft
525	691037	Tube-Dipstick	1005	499603	Fan-Flywheel
526	691108	Screw (Regulator)	1013	690954	Nipple-Oil Filter
544	692034	Armature-Starter	1017	690770	Screen-Oil Pump
552	690552	Bushing-Governor Crank	1019	790094	Kit-Label
552A	690553	Bushing-Governor Crank	1022	690971	*+ Gasket-Rocker Cover
562	690311	Bolt (Governor Control Lever)	1023	499599	Cover-Rocker (Cylinder 1)
573	691009	Plate-Back	1023A	499600	Cover-Rocker (Cylinder 2)
601	691038	Clamp-Hose	1024	499054	Pump-Oil
615	698290	Retainer-Governor Shaft	1026	690981	Rod-Push (Steel)
616	691045	Crank-Governor	1026A	690982	Rod-Push (Aluminum)
628	691108	Screw (Fuel Pump Bracket)	1027	492932	Filter-Oil
633	695414	∅ Seal-Choke/Throttle Shaft	1029	690972	Arm-Rocker
635	66538	Boot-Spark Plug	1035	691042	Shaft-Pump
654	690958	Nut (Carburetor)	1036	695704	Label-Emission
668	691215	Spacer	1051	691265	Ring-Retaining
691	690657	• Seal-Governor Shaft	1054	280275	Tie-Cable
695	693149	Screw (Ring Gear)	1058	275475	Owner's Manual
697	690372	Screw (Drive Cap)	1070	690372	Screw (Flywheel Fan)
703	691010	Clip	1090	691293	Retainer-Brush
718	690959	Pin-Locating	1095	699822	Kit-Valve Overhaul
726	499612	Gear-Ring	1100	690973	Pivot-Rocker Arm
741	690980	Gear-Timing	1119	691183	Screw (Alternator)
742	690328	Retainer-E Ring	1127	690992	Screw (Float Bowl)
750	696999	Screw (Oil Pump Cover)	1329	407577-0027	Replacement Engine (Transfer the Governor Spring and Speed Limiter Bracket)
783	693058	Gear-Pinion			
788	691039	Bracket-Fuel Pump			
789	698330	Harness-Wiring	1330	273521	Repair Manual
797	691029	Nut (Brush Retainer)			
797A	693167	Nut (Brush Retainer)			• Included in Engine Gasket Set, Key. No. 358
798	697890	Screw (Rocker Arm)			∅ Included in Carburetor Overhaul Kit, Key. No. 121
801	691283	Cap-Drive			‡ Included in Carburetor Gasket Set, Key. No. 977
802	691286	Cap-End			+ Included in Valve Gasket Set, Key. No. 1095
803	693757	Housing-Starter			
842	691031	• Seal-Dipstick/Tube			
847	499602	Dipstick/Tube Assembly			
851	493880	Terminal-Spark Plug			
865	691012	Cover-Air Guide			
865A	691014	Cover-Air Guide			
865B	691015	Cover-Air Guide			
868	690968	*+ Seal-Valve			
914	691127	Screw (Rocker Cover)			

NOTE: All component dimensions given in U.S. inches 1 inch = 25.4 mm