

REPAIR PARTS MANUAL
MODEL NO. 277460
Lawn Tractor

24HK 48" KLIPPER 04

CRAFTSMAN®

HOW TO USE THIS MANUAL

This manual is designed to provide the customer with a means to identify the parts on his/her tractor when ordering repair parts. The illustrations may or may not represent the actual assemblies; therefore, it is not recommended to use this manual as a guide to assemble or disassemble the tractor. Some hardware and parts are drawn larger in order to more readily identify them.

Each tractor has its own model number.

The model number for your tractor can be found on the fender under the seat.

When ordering parts, always give the following information:

- Product - "Tractor"
- Model Number - "277460"
- Part Number
- Part Description

TABLE OF CONTENTS

SCHEMATIC	3
ELECTRICAL.....	4-5
CHASSIS.....	6-7
DRIVE.....	8-9
STEERING	10-11
SEAT	12
DECALS.....	13
ENGINE.....	14-15
MOWER LIFT	16-17
MOWER DECK	18-19
TRANSAXLE.....	20-21
ENGINE BREAKDOWN.....	22-26
WARRANTY	27

TRACTOR- -MODEL NO. 917. 277460

SCHEMATIC

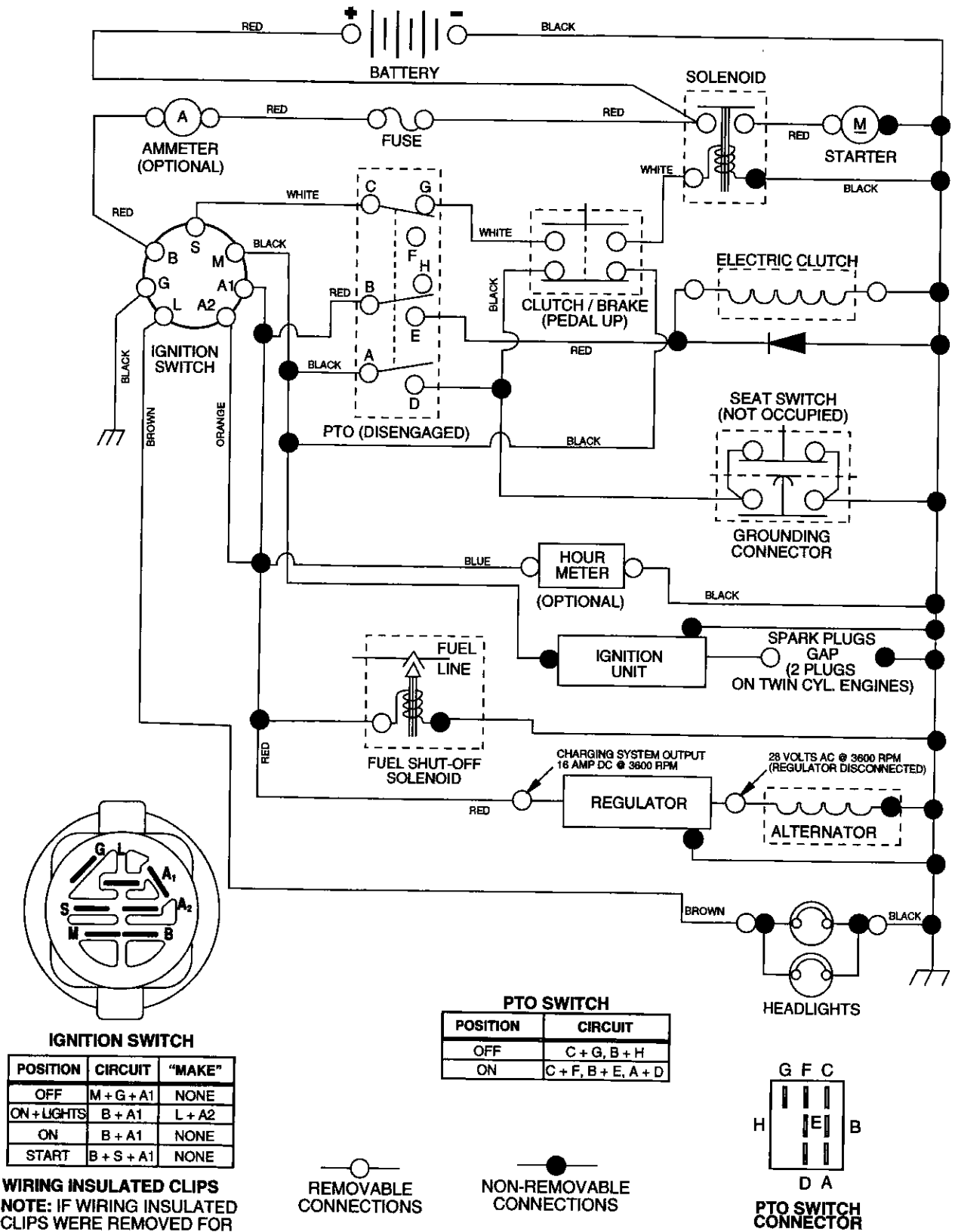

WIRING INSULATED CLIPS
NOTE: IF WIRING INSULATED CLIPS WERE REMOVED FOR SERVICING OF UNIT, THEY SHOULD BE REPLACED TO PROPERLY SECURE YOUR WIRING.

REPAIR PARTS

TRACTOR- -MODEL NO. 917. 277460

ELECTRICAL

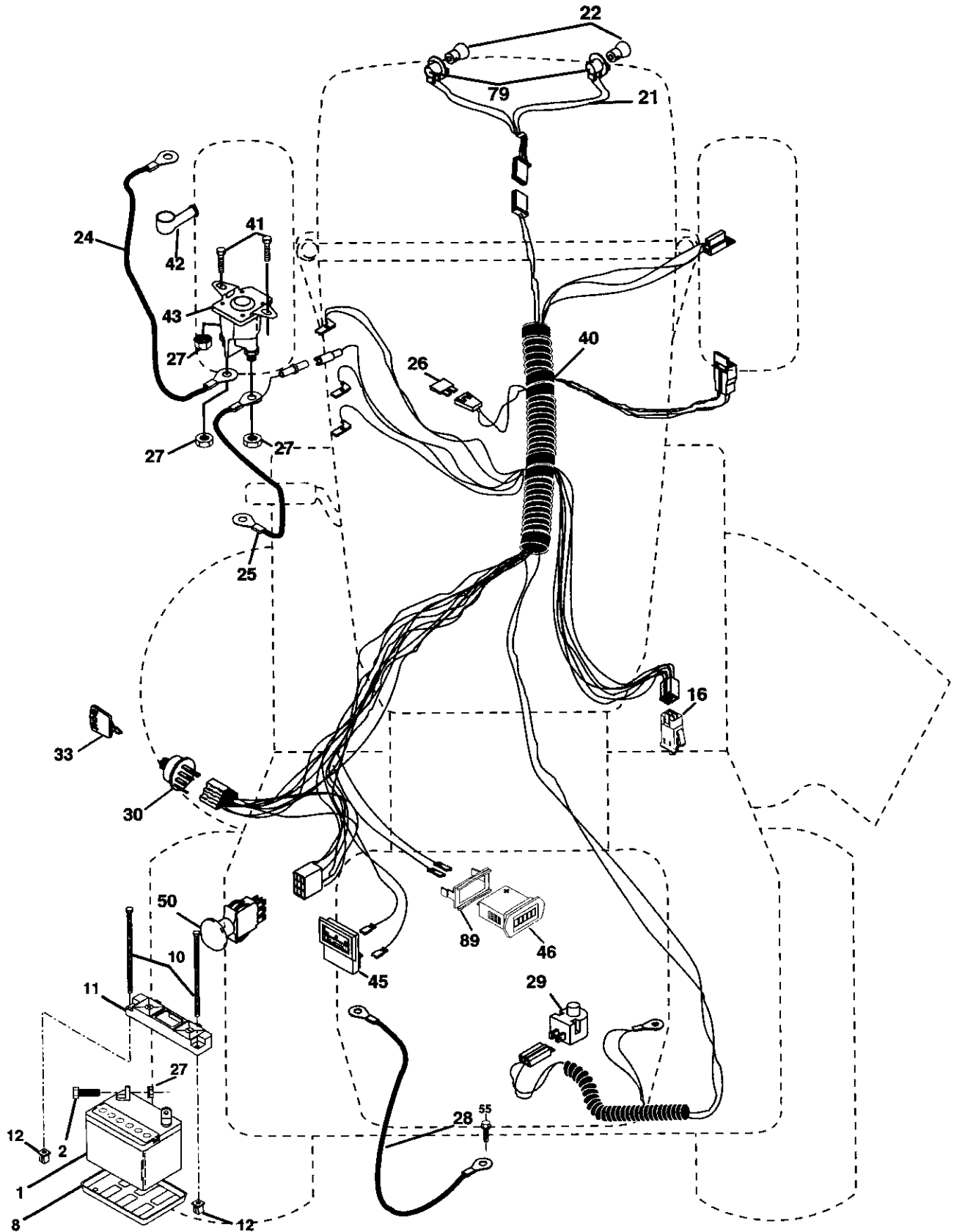

REPAIR PARTS

TRACTOR- -MODEL NO. 917. 277460

ELECTRICAL

KEY NO.	PART NO.	DESCRIPTION
1	144927	Battery
2	74760412	Bolt, Hex 1/4-20 x 3/4
8	7603J	Tray, Battery
10	145211	Bolt, Battery, Front 1/4-20 x 7-1/2
11	150109	Holddown, Battery, Front
12	145769	Nut, Push, Nylon, Battery, Front 1/4
16	176138	Switch, Interlock
21	175688	Harness, Light
22	4152J	Bulb Light #1156
24	8860R	Cable Starter
25	146148	Cable
26	175158	Fuse
27	73510400	Nut, Hex, Keps 1/4-20 unc
28	145491	Cable, Ground
29	121305X	Switch, Seat
30	175566	Switch, Ignition
33	140403	Key
40	188031	Harness, Ignition
41	17720408	Screw Thd Cut 1/4-20 x 1/2
42	131563	Cover Terminal
43	178861	Soloid w/brass plunger
45	122822X	Ammeter
46	169635	Hourmeter
50	174652	Switch, PTO
55	17490508	Screw, Thd. Roll. 5/16-18 x 1/2
79	175242	Socket Asm Bulb Twistlock
89	169639	Bracket Snap-in

NOTE: All component dimensions give in U.S. inches
1 inch = 25.4 mm

REPAIR PARTS

TRACTOR- -MODEL NO. 917. 277460

CHASSIS AND ENCLOSURES

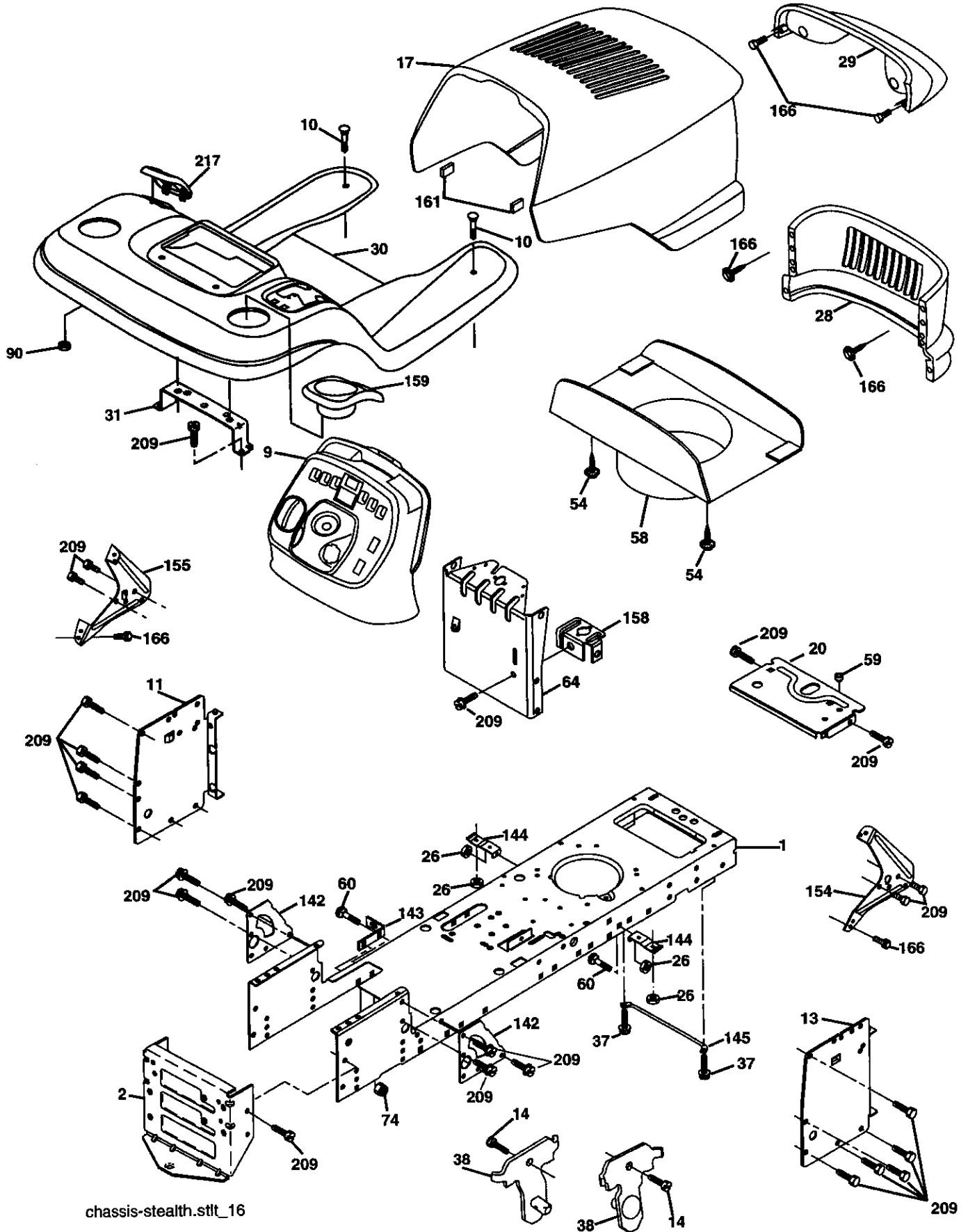

chassis-stealth.stlt_16

REPAIR PARTS

TRACTOR- -MODEL NO. 917. 277460

CHASSIS AND ENCLOSURES

KEY NO.	PART NO.	DESCRIPTION
1	174619	Chassis
2	176554	Drawbar
9	163967X428	Dash
10	72140608	Bolt RDHD SQNK 3/8-16 x 1
11	167203	Panel, Dash, LH
13	188702X010	Panel, Dash, RH
14	17490608	Screw Thdrol 3/8-16 x 1/2
17	175260X615	Hood Assembly
20	162026	Plate Battery
26	STD541437	Locknut, Hex, with Insert 3/8-16 unc
28	174515X615	Grille
29	161840	Lens, Bar
30	179131X615	Fender/Footrest
31	139976	Bracket, Fender/Support
37	17490508	Screw, Thdrol. 5/16-18 x 1/2 TYT
38	175710	Bracket Asm Pivot Mower Rear
54	161464	Screw Hex Wshd 8-18 x 7/8
58	175351	Duct Hood
59	187495	Bushing 1.375 OD
60	STD533707	Bolt Rdhd Sqnk 3/8-16 unc x 3/4
64	174997	Dash Lower
74	STD541437	Nut Crownlock 3/8-16 unc
90	124346X	Nut Self Thrd Wshd 1/4 Zinc
142	175702	Plate Reinforcement
143	186689	Bracket Swaybar Chassis
144	175582	Bracket Footrest
145	156524	Rod Pivot Chassis/Hood
154	161897	Bracket Dash Rh
155	161900	Bracket Dash Lh
158	162037	Parking Brake Bkrt
159	179950X428	Cupholder
161	164655	Bumper Extrusion .600 x 3.50
166	171875	Screw HWHDH:-Lo. #13-16 x 3/4
209	17000612	Screw Hexwsh Thdr 3/8-16 x 3/4
217	179132X418	Console Fuel Window

NOTE: All component dimensions give in U.S. inches
1 inch = 25.4 mm

REPAIR PARTS

TRACTOR- -MODEL NO. 917. 277460

DRIVE

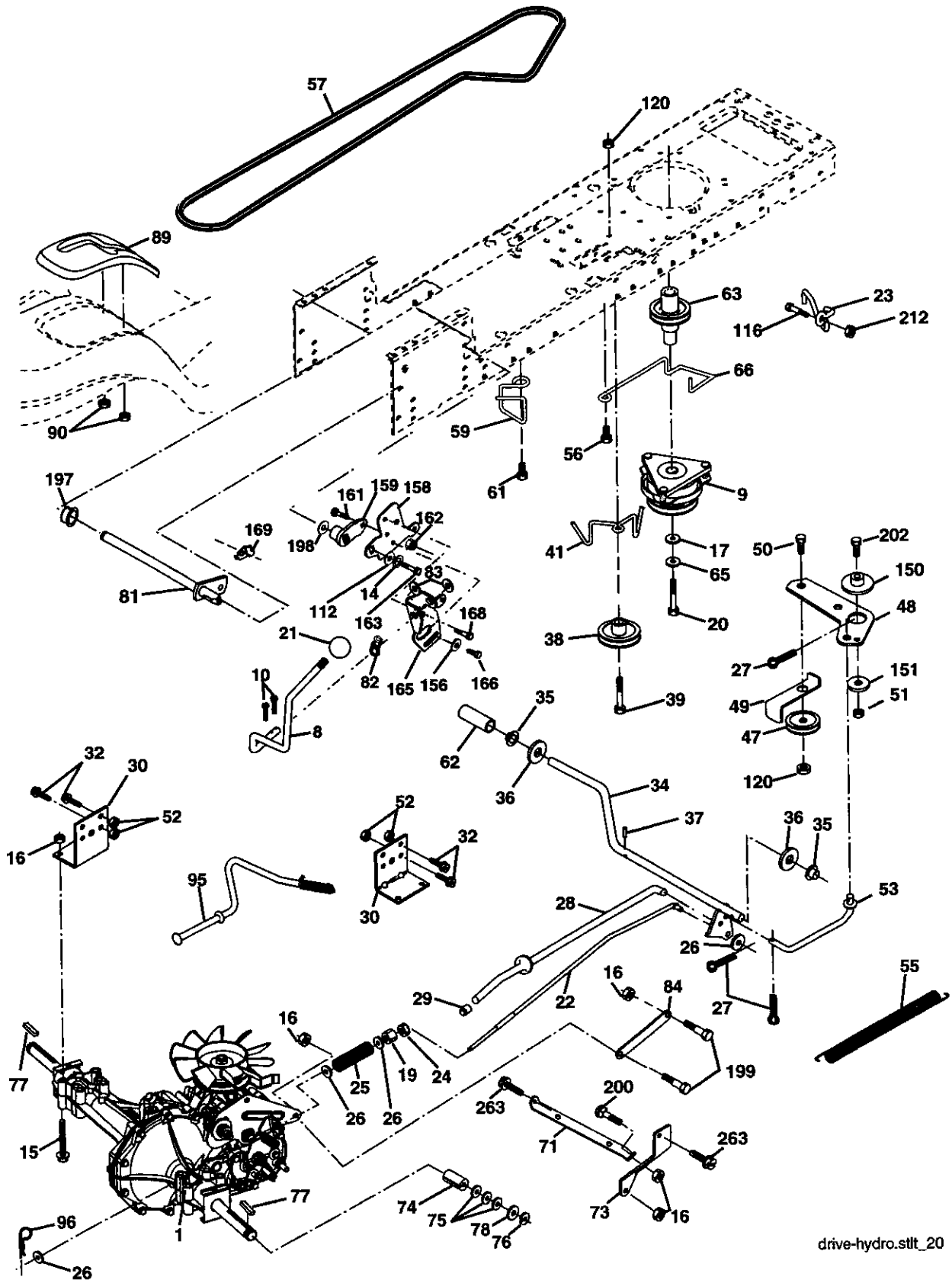

drive-hydro.stlt_20

REPAIR PARTS

TRACTOR- -MODEL NO. 917. 277460

DRIVE

KEY NO.	PART NO.	DESCRIPTION	KEY NO.	PART NO.	DESCRIPTION
1	---	Transaxle, HydroGear, Model 314-0510 (See Break down)	65	10040700	Washer
8	165866	Rod Shift Fend.	66	154778	Keeper Belt Engine
9	179334	Clutch Electric	71	169183	Strap Torque LH
10	76020416	Pin Cotter 1/8 x 1	73	169182	Strap Torque RH
14	10040400	Washer Lock Hvy 1/4	74	137057	Spacer, Axle
15	74490544	Bolt Hex Flghd 5/16-18 Gr. 5	75	121749X	Washer 25/32 x 1-1/4 x 16 Ga.
16	73800500	Nut Lock Hex W/Ins. 5/16-18 unc	76	12000001	E-Ring
17	126197X	Washer 1-1/2 OD x 15/32 ID x .250	77	123583X	Key, Square
19	73800600	Nut Lock Hex W/Wsh 3/8-16 unc	78	121748X	Washer 25/32 x 1-5/8 x 16 Ga.
20	173937	Bolt Hex 7/16-20 x 4 x Gr. 5-1.5	81	165596	Shaft Assy. Cross Taper
21	130564	Knob	82	165711	Spring Torsion
22	169498	Rod, Brake	83	19171216	Washer 17/32 x 3/4 x 16 Ga.
23	178289	Bracket Anti-Rotation	84	169594	Link Transaxle
24	73350600	Nut, Hex Jam 3/8-16 unc	89	164890X428	Console, Shift
25	106888X	Spring, Brake Rod	90	124346X	Nut Self-Thd Wsh-hd 1/4 Zinc
26	19131316	Washer	95	170201	Rod Bypass
27	76020412	Pin Cotter 1/8 x 3/4 CAD.	96	4497H	Retainer Spring 1" Zinc/Cad
28	175765	Rod, Parking Brake	112	19091210	Washer 9/32 x 3/4 x 10 Ga.
29	124236X	Knob Brake Parking	116	72140608	Bolt RDHD SQNK 3/8-16 unc x 1
30	169592	Bracket, Transaxle	120	73900600	Nut Lock Fig 3/8-16 unc
32	74760512	Bolt Hex Hd 5/16-18 unc x 3/4	150	175456	Spacer Retainer
34	175578	Shaft, Foot Pedal	151	19133210	Washer 13/32 x 2 x 10 Ga.
35	120183X	Bearing, Nylon	156	166002	Washer 5/16 ID x 1.0 x .125
36	19211616	Washer	158	165589	Bracket Shift Mount
37	1572H	Pin, Roll	159	183900	Hub Shift
38	179114	Pulley, Composite	161	72140406	Bolt Rdhd Sqnk 1/4-20 x 3/4 Gr. 5
39	72110622	Bolt Rdhd 3/8-16 unc x 2-3/4 Gr. 5	162	73680400	Nut Crownlock 1/4-20 unc
41	175556	Keeper, Belt Idler Flat	163	74780416	Bolt Hex Fin 1/4-20 unc x 1 Gr. 5
47	127783	Pulley, Idler, V-Groove	165	165623	Bracket Pivot Lever
48	154407	Bellcrank Clutch Grnd Drw Stl	166	17490510	Screw 5/16-18 x 5/8
49	123205X	Retainer, Belt	168	165492	Bolt Shoulder 5/16-18 x .561
50	72110612	Bolt	169	165580	Plate Fastener Cross Shf.
51	73680600	Nut Crownlock 3/8-16 unc	197	169613	Nyliner Snap-in 5/8 ID
52	73680500	Nut, Crownlock 5/16-18 unc	198	169593	Washer Nyl 7/8 ID x .105"
53	105710X	Link, Clutch	199	169612	Bolt Shoulder 5/16-18 unc
55	105709X	Spring, Return, Clutch	200	72140508	Bolt Rdhd Sqnk 5/16-18 unc x 1
56	17060620	Screw 3/8-16 x 1-1/4	202	72110614	Bolt Carr Sh 3/8-16 x 1-3/4 Gr. 5
57	140294	V-Belt, Ground Drive	212	145212	Nut HexFlange Lock
59	169691	Keeper, Center Span	263	17000612	Screw 3/8-16 x .75
61	17120614	Screw 3/8-16 x .875			
62	123533X	Cover, Pedal			
63	174607	Pulley, Engine			

NOTE: All component dimensions give in U.S. inches
1 inch = 25.4 mm

REPAIR PARTS

TRACTOR- -MODEL NO. 917. 277460

STEERING ASSEMBLY

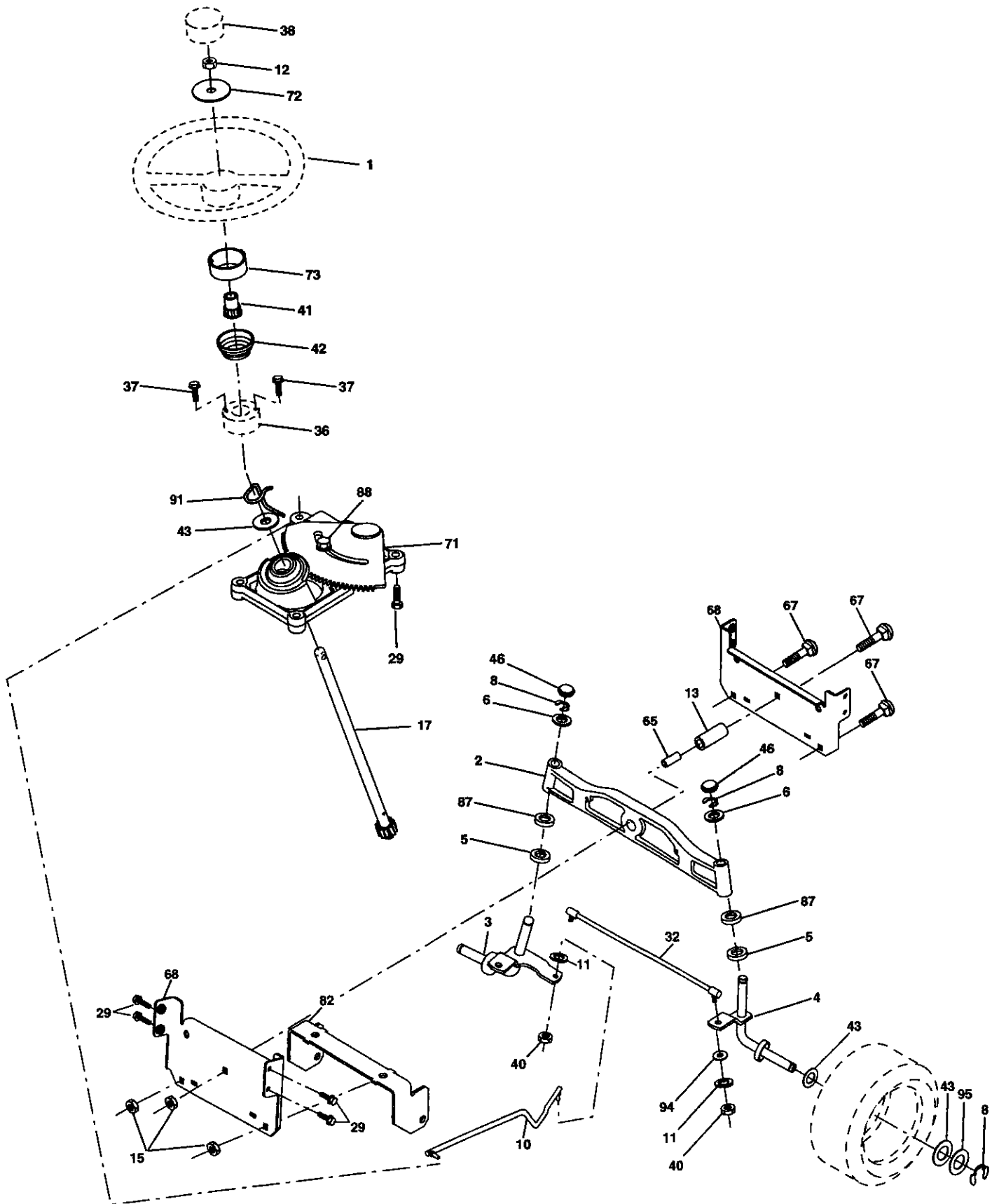

steering_stealth_prem_10

REPAIR PARTS

TRACTOR- -MODEL NO. 917. 277460

STEERING ASSEMBLY

KEY NO.	PART NO.	DESCRIPTION
1	159944X428	Wheel Steering
2	184706	Axle Asm
3	169840	Spindle Asm LH
4	169839	Spindle Asm RH
5	6266H	Bearing Race Thrust Harden
6	121748X	Washer 25/32 x 1-5/8 x 16 Ga.
8	1200029	Ring Klip #t5304-75
10	175121	Link Drag
11	10040600	Washer Lock Hlcl Spr 3/8
12	73940800	Nut Hex Jam Toplock 1/2-20 unf
13	136518	Spacer Bearing Axle Front
15	145212	Nut Hex Flange Lock
17	177883	Shaft Asm. Steering
29	17000612	Screw 3/8-16 x 3/4
32	180580	Rod Tie
36	155105	Bushing Strg
37	152927	Screw
38	159946X428	Insert Cap Strg Wh
39	19182411	Washer 9/16 ID x 1-1/2 OD 11Ga.
40	73540600	Nut Crownlock 3/8-24
41	159945	Adaptor Wheel Strg
42	163888X428	Boot Steering
43	121749X	Washer 25/32 1 1/4 x 16 Ga.
46	184946X505	Cap Spindle
65	160367	Spacer Brace Axle
67	72110618	Bolt, Rdhd Sq 3/8-16 unc x 2-1/4
68	169827	Axle, Brace
71	175146	Steering Asm.
73	160135X428	Extension Steering Stealth
82	169835	Bracket Susp. Chassis Front
87	173966	Washer Flat .781 x 1-1/2 x .15
88	175118	Bolt Shoulder 7/16-20 unc
91	175553	Clip Steering
94	19121414	Washer 3/8 x 7/8 x 14 Ga.
95	188967	Washer Harden .793 x .637 x .060

NOTE: All component dimensions given in U.S. inches
1 inch = 25.4 mm

REPAIR PARTS

TRACTOR- -MODEL NO. 917. 277460

SEAT ASSEMBLY

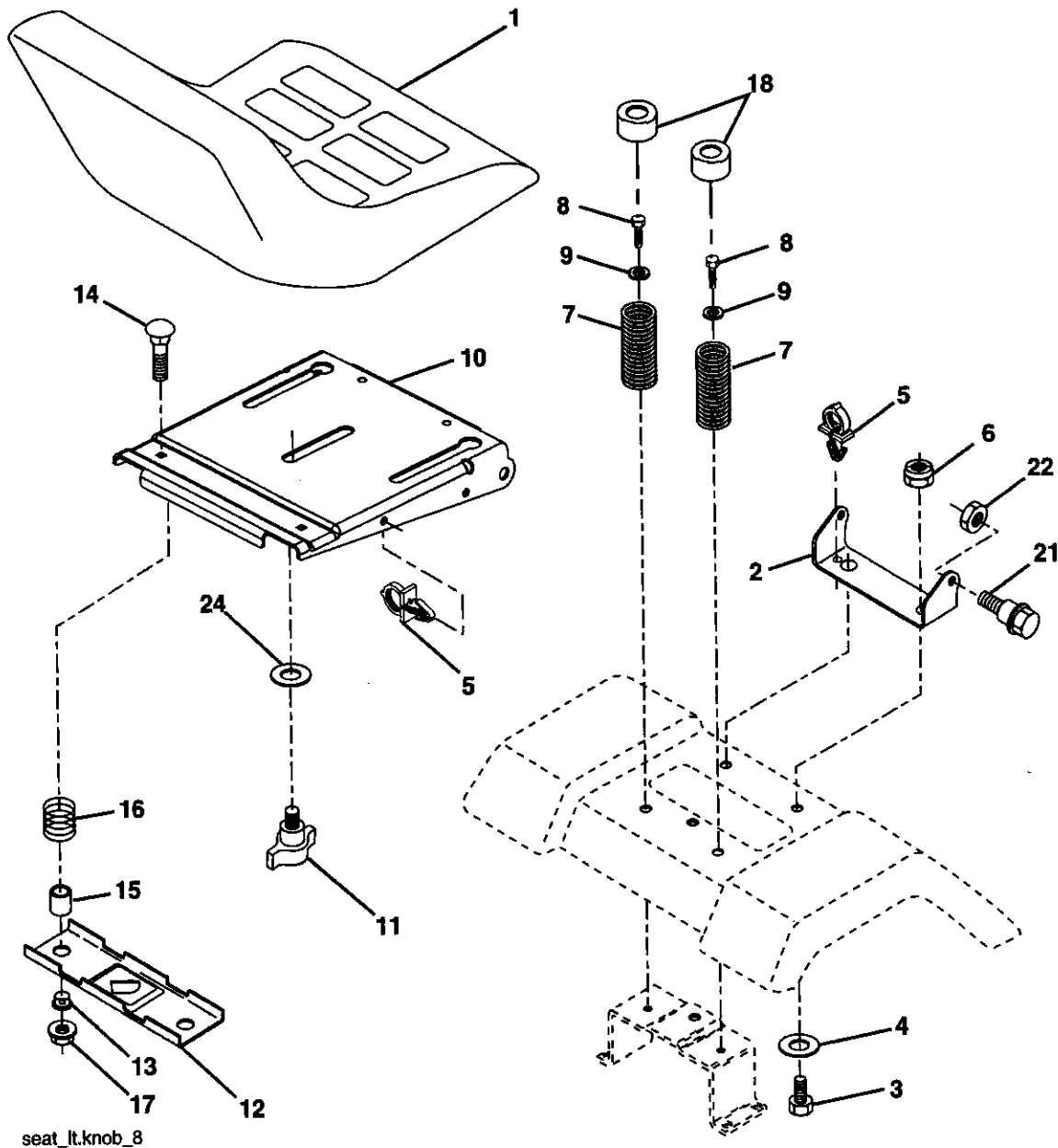

KEY NO.	PART NO.	DESCRIPTION
1	180598	Seat
2	180166	Bracket Pivot Seat
3	STD523710	Bolt Fin Hex 3/8-16 unc x 1
4	19131610	Washer 13/32 x 1 x 10 Ga
5	145006	Clip Push-In
6	STD541437	Nut Hex w/Ins. 3/8-16 unc
7	124181X	Spring Seat Cprsn
8	17000616	Screw 3/8-16 x 1-1/2
9	19131614	Washer 13/32 x 1 x 14 Ga.
10	180186	Pan Seat
11	166369	Knob Seat Adj. Wingnut
12	121246X	Bracket Mounting Switch

KEY NO.	PART NO.	DESCRIPTION
13	121248X	Bushing Snap Blk Nyl 50 Id
14	72050412	Bolt Rdhd Sqnk 1/4-20 x 1-1/2
15	121249X	Spacer Split 28x .88 Zinc
16	123740X	Spring Cprsn Plate 1.310 Ga
17	123976X	Nut Lock 1/4 Lge Flg Gr. 5 Zinc
18	124238X	Cap Spring Seat
21	171852	Bolt Shoulder 5/16-18 unc
22	STD541431	Nut Hex Lock W/Ins 5/16-18
24	19171912	Washer 17/32 x 1-3/16 x 12 Ga.

NOTE: All component dimensions given in U.S. inches
1 inch = 25.4 mm

REPAIR PARTS

TRACTOR- -MODEL NO. 917. 277460

DECALS

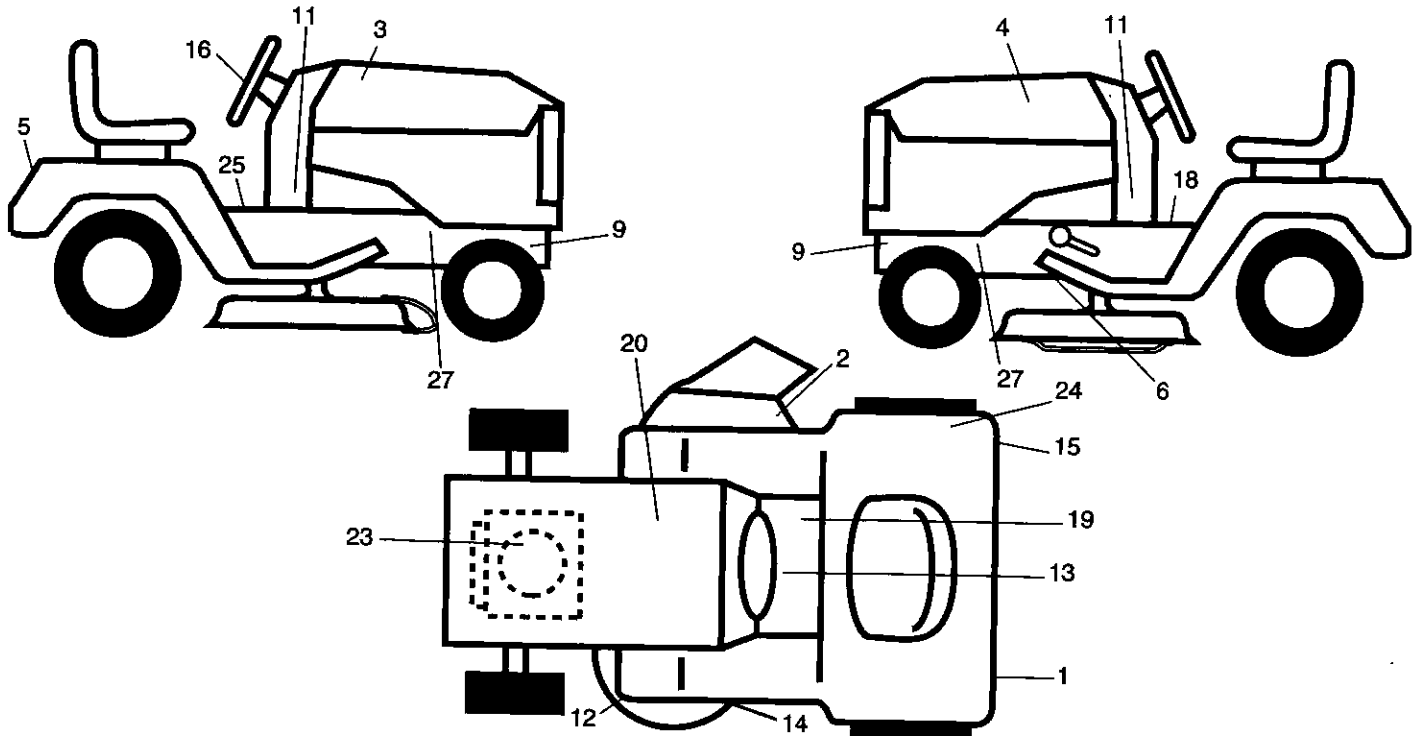

KEY NO.	PART NO.	DESCRIPTION
1	187407	Reflector, LH
2	182166	Decal, Cutfinger
3	186242	Decal, Hood RH
4	186243	Decal, Hood LH
5	186572	Decal, Seat Craftsman
6	146046	Decal, V-Belt, Drive Schematic
9	159736	Decal, Hot Muffler
11	189637	Decal, Panel, Dash
12	178482	Decal, Mower, Heavy-Duty
13	164656	Decal, Dash
14	175291	Decal, V-Belt, Schematic
15	187408	Decal, Reflector, RH
16	164065	Decal, Steering Wheel

KEY NO.	PART NO.	DESCRIPTION
18	140837	Decal, Brake Parking
19	145498	Decal, Read Owner's Manual
20	145005	Decal, Battery
23	189684	Decal, Engine
24	180433	Decal, Fender DB/CE
25	159737	Decal, Brake/Clutch Symbol
27	166960	Decal By-Pass
--	162598	Decal, Drawbar Load
--	184310X428	Pad, Footrest, ST/LT, LH
--	184311X428	Pad, Footrest, ST/LT, RH
--	191005	Manual, Operator's (Euro)
--	191006	Manual, Operator's (Scand)
--	191036	Manual, Parts

WHEELS & TIRES

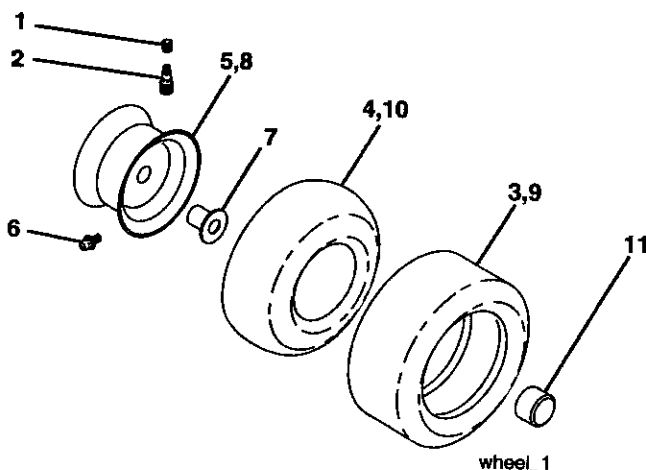

KEY NO.	PART NO.	DESCRIPTION
1	59192	Cap Valve Tire
2	65139	Stem Valve
3	106222X	Tire F Ts 15 x 6 0 - 6 Service
4	59904	Tube Front (Service Item Only)
5	106732X417	Rim Asm 6"front Service
6	278H	Fitting Grease (Front Wheel Only)
7	9040H	Bearing Flange (Front Wheel Only)
8	106108X417	Rim Asm 8"rear Service
9	122082X	Tire R Ts 20 x 10-8 C Service
10	7152J	Tube Rear (Service Item Only)
11	104757X428	Cap Axle Blk 1 50 x 1 00
--	144334	Sealant, Tire (10 oz. Tube)

NOTE: All component dimensions given in U.S. inches
1 inch = 25.4 mm

REPAIR PARTS

TRACTOR- -MODEL NO. 917. 277460

ENGINE

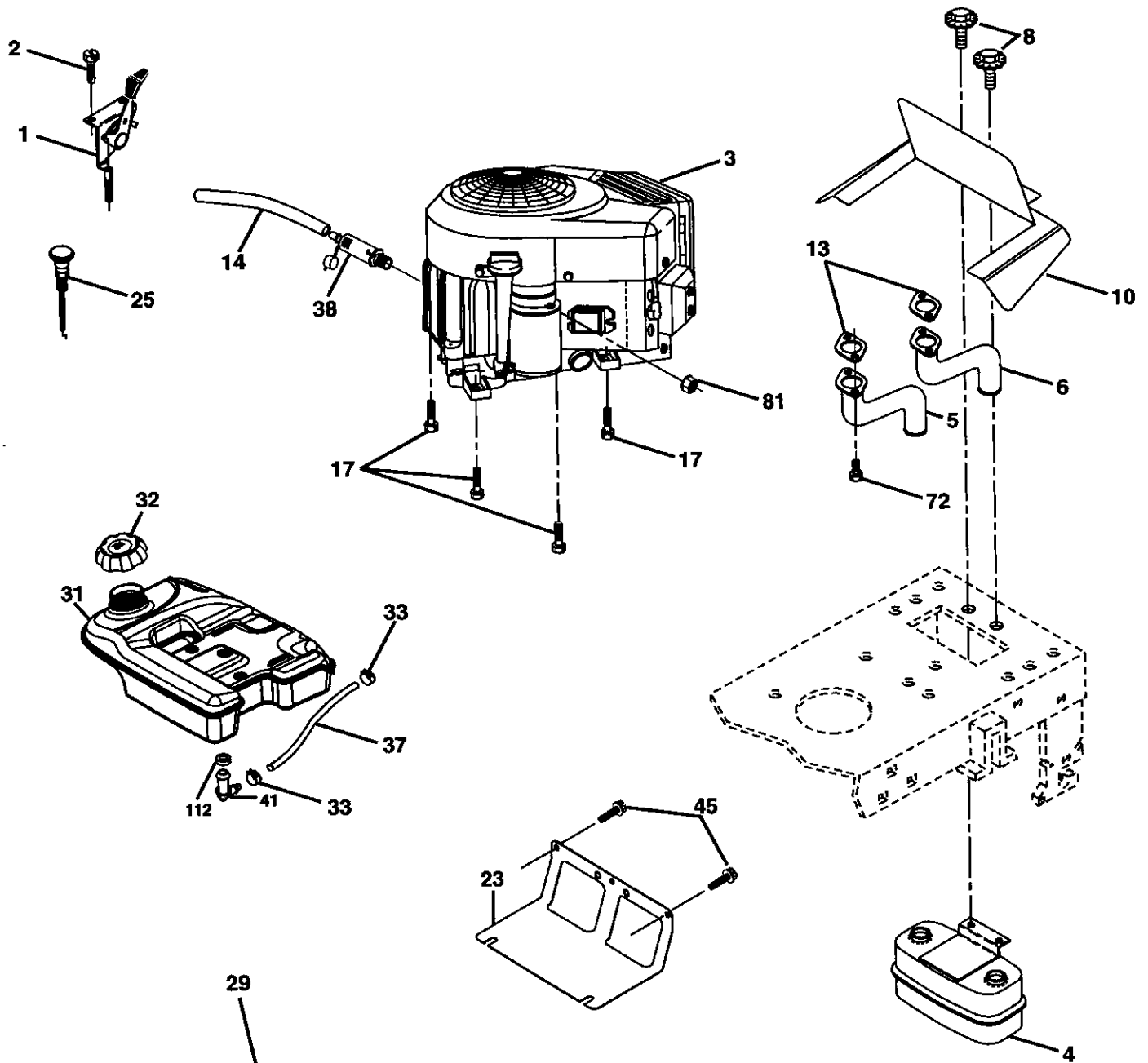

OPTIONAL EQUIPMENT
Spark Arrester

engine-bs intek-twin_39

REPAIR PARTS

TRACTOR- -MODEL NO. 917. 277460

ENGINE

KEY NO.	PART NO.	DESCRIPTION
1	175437X428	Control Throttle
2	171875	Screw Hwhd Hi-Lo #13-16 x 3/4
3	-----	Engine, Briggs Model No. 445777-0352-E1 (See Breakdown)
4	149723	Muffler Asm Twin Lo-Tone
5	159955	Pipe Exhaust LH Intek
6	160589	Pipe Exhaust RH Intek
8	171877	Bolt 5/16-18 Unc x 3/4 w/Sems
10	162797	Shield Browning Intek II
13	165391	Muffler Gasket
14	148456	Tube Drain oil
17	17060624	Screw Thdrol 3/8-16 x 1-1/2
23	169837	Shield Heat
25	175440X428	Choke Control
29	137180	Kit Spark Arrestor (Flat Scrn)
31	179022	Tank Fuel 4.0 Rear
32	179124X428	Cap Asm Fuel
33	123487X	Clamp Hose Black
37	8543R	Line Fuel
38	181654	Plug Drain Oil Easy
41	139277	Stem Tank Fuel
45	17000612	Screw Hexwsh Thdr 3/8-16 x 3/4
72	183906	Screw 5/16-18 x 1
81	73510400	Nut Keps Hex 1/4-20 unc
112	3645J	Bushing

NOTE: All component dimensions given in U.S. inches
1 inch = 25.4 mm

REPAIR PARTS

TRACTOR- -MODEL NO. 917. 277460

MOWER LIFT

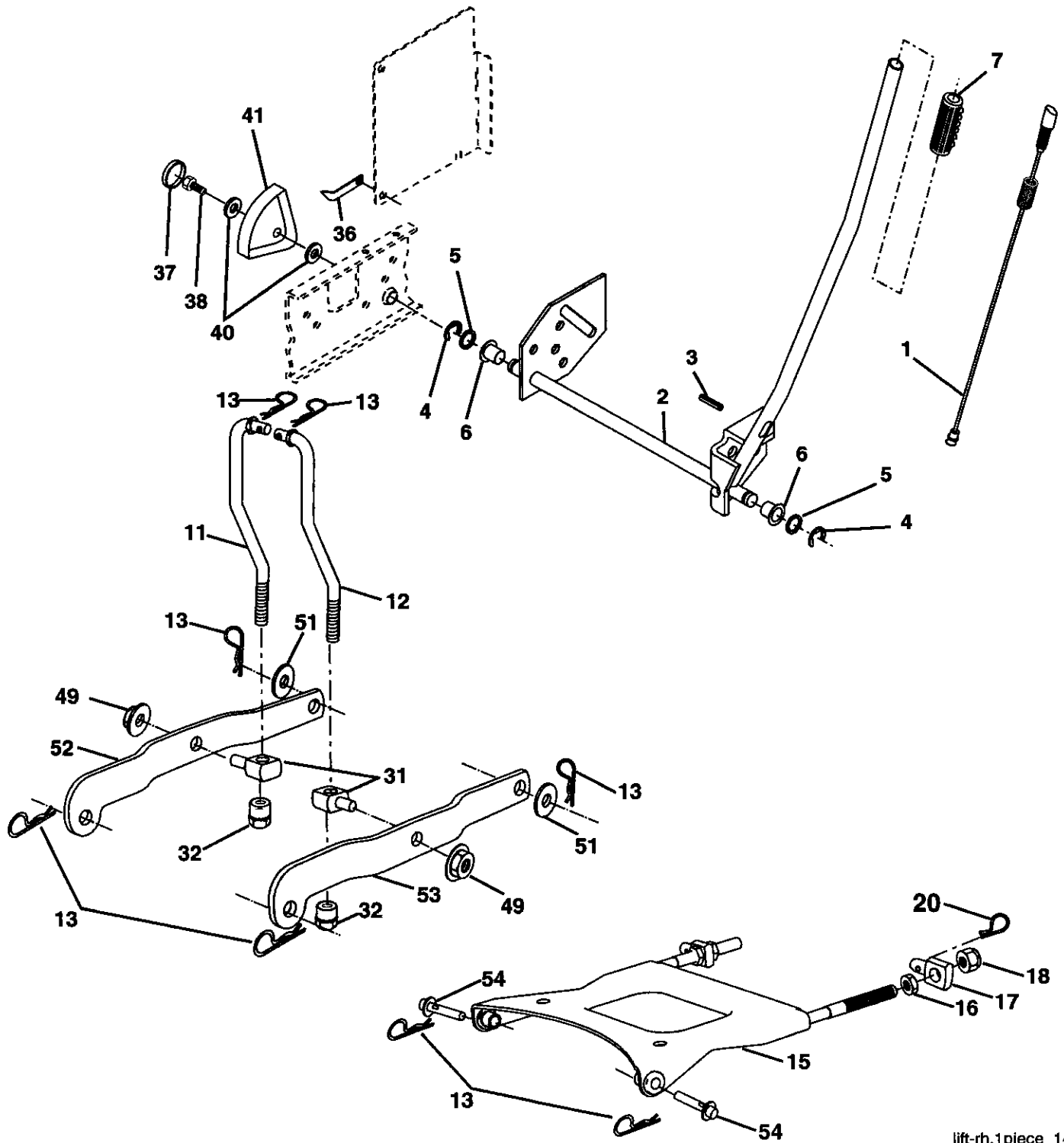

lift-rh.1piece_14

REPAIR PARTS

TRACTOR- -MODEL NO. 917. 277460

MOWER LIFT

KEY NO.	PART NO.	DESCRIPTION
1	179504	Plunger Assembly
2	159476	Shaft Assembly, Lift
3	178981	Pin, Groove
4	12000002	E-Ring
5	19211621	Washer 21/32 x 1 x 21 Ga.
6	120183X	Bearing, Nylon
7	175830	Grip, Handle, Fluted
11	175370	Link, Lift, L.H.
12	175371	Link, Lift, R.H.
13	4939M	Retainer Spring
15	175562	Plate Asm Suspension Front
16	73350800	Nut Hex Jam 1/2-13 unc
17	175689	Trunnion Front Susp.
18	73800800	Nut Lock w/Wsh 1/2-13 unc
20	163552	Retainer Spring
31	176205	Trunion Sups. Arm.
32	175994	Nut Lift Link 7/16-20
36	155097	Pointer Height Indicator
37	123935X	Plug Hole
38	17060516	Screw 5/16-18 x 1
40	19112410	Washer 11/32 x 1-1/2 x 10 Ga.
41	155098	Indicator Height Stit
49	145212	Nut Hex/Large Lock
51	19171416	Washer 17/32 x 7/8 x 16 Ga.
52	175378	Arm Suspension Rear LH
53	175802	Arm Suspension Rear RH
54	175560	Pin Flange

NOTE: All component dimensions given in U.S. inches
1 inch = 25.4 mm

REPAIR PARTS

TRACTOR- -MODEL NO. 917. 277460

MOWER

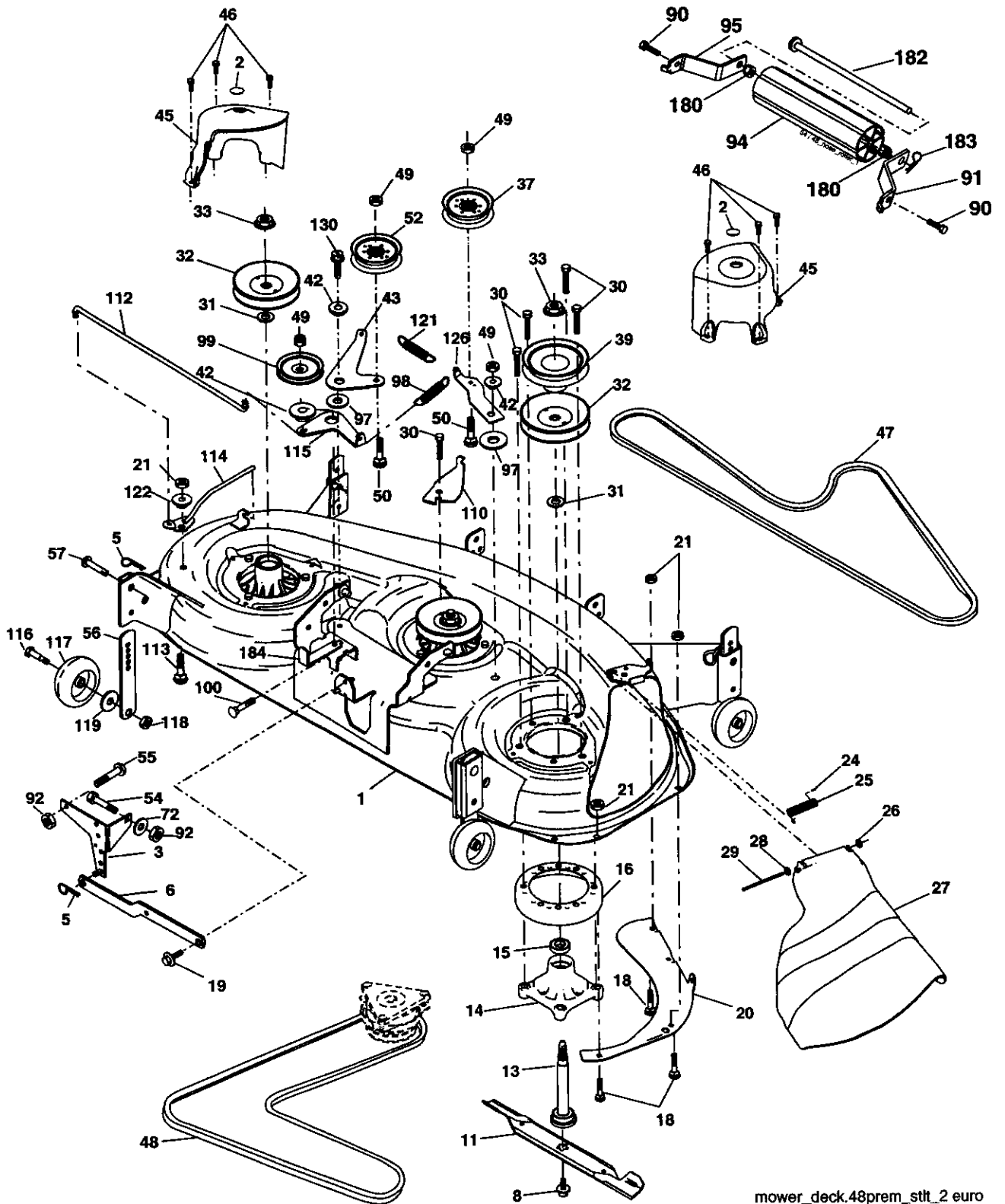

mower_deck.48prem_stlt_2 euro

REPAIR PARTS

TRACTOR- -MODEL NO. 917. 277460

MOWER

KEY NO.	PART NO.	DESCRIPTION	KEY NO.	PART NO.	DESCRIPTION
1	180358	Deck Weldment Mower 48	56	155986	Bar Pnt Adj.
2	178345	Plug Hole Mandrel Exp.	57	156941	Pin Head Rivet
3	138017	Bracket Asm., Sway Bar	72	19131312	Washer 13/32 x 13/16 x 12 Ga.
5	4939M	Retainer Spring	90	74760516	Bolt Hex Hd. 5/16-18 unc x 1
6	178024	Bar Sway Deck	91	180535	Bracket Asm Noseroller RH
8	174365	Bolt 7/16 Asm. Blade	92	73800600	Nut Lock Hex w/Ins 3/8-16 unc
11	180054	Blade, 48" Hi-Lift	94	176066	Noseroller
13	174360	Shaft Mandrel Asm. Greaseable	95	180534	Bracket Asm Noseroller LH
14	174358	Housing Mandrel	97	178515	Washer Hardened
15	110485X	Bearing, Ball, Mandrel	98	179479	Spring Primary Drive
16	174493	Stripper Mandrel Deck	99	184058	Pulley Idler"V"
17	72110610	Bolt RDHD Sq Neck 3/8-16 x 1.25	100	72110616	Bolt RDHD Sqnk 3/8-16 unc x 2
18	72140505	Bolt, Carriage 5/16-18 x 5/8	110	175016	Arm Spring Secondary
19	132827	Bolt, Hex Hd, Shoulder 5/16-18	112	174387	Link Tension Relief Lever
20	174378	Baffle, Vortex Mower	113	72110506	Bolt Carr. 5/16-18 x 3/4
21	73680500	Nut, Crownlock 5/16-18 unc	114	174384	Tension Asm Relief Lever
24	105304X	Cap, Sleeve	115	174609	Arm Spring Tension Relief
25	178102	Spring, Torsion	116	184219	Bolt, Shoulder
26	110452X	Nut, Push	117	174873	Gauge Wheel
27	180655X428	Deflector Shield	118	73930600	Nut, Centerlock 3/8-16 unc
28	19111016	Washer 11/32 x 5/8 x 16 Ga.	119	19121414	Washer 3/8 x 7/8 x 14 Ga.
29	131491	Rod, Hinge	121	174371	Spring Secondary Drive
30	173984	Screw, Thdroll	122	174606	Bushing Pivot Tension Relief
31	187690	Washer, Spacer Mower Vented	126	174372	Arm, Idler, Primary Deck
32	177865	Pulley, Mandrel	130	17000616	Screw 3/8-16 x 1
33	178342	Nut, Fig. Top Lock Cntr. 9/16	132	17000612	Screw 3/8-16 x .75
37	177968	Pulley, Idler	180	73800500	Nut Lock Hx w/Ins 5/16-18 unc
39	174375	Pulley, Idler, Driven	182	179127	Rod Roller Nose
42	122052X	Spacer, Retainer	183	163552	Retainer Spring
43	174373	Arm, Idler Secondary	184	173979	Keeper Belt Idler
45	180806	Cover, Mandrel Deck	--	174356	Mandrel Asm. Service (Includes Key Nos. 13-15)
46	137729	Screw, Thdroll. 1/4-20 x 5/8	--	181579	Replacement Mower, Complete (Std. Deck - Order separately nose roller components key nos. 91, 94, 95, 132, 182, and 183)
47	180808	V-Belt, Mower, Secondary			
48	174368	V-Belt, Mower, Primary			
49	73900600	Nut Lock Fig. 3/8-16 unc			
50	72110612	Bolt, Carr. 3/8-16 x 1-1/2 Gr. 5			
52	175820	Pulley Idler Flat			
54	74780616	Bolt Fin Hex 3/8-16 unc x 1 Gr. 5			
55	72140608	Bolt Rdhd Sqnk 3/8-16 unc x 1			

NOTE: All component dimensions given in U.S. inches
1 inch = 25.4 mm

REPAIR PARTS

TRACTOR- -MODEL NO. 917. 277460
 HYDRO GEAR TRANSAXLE - MODEL NUMBER 314-0510

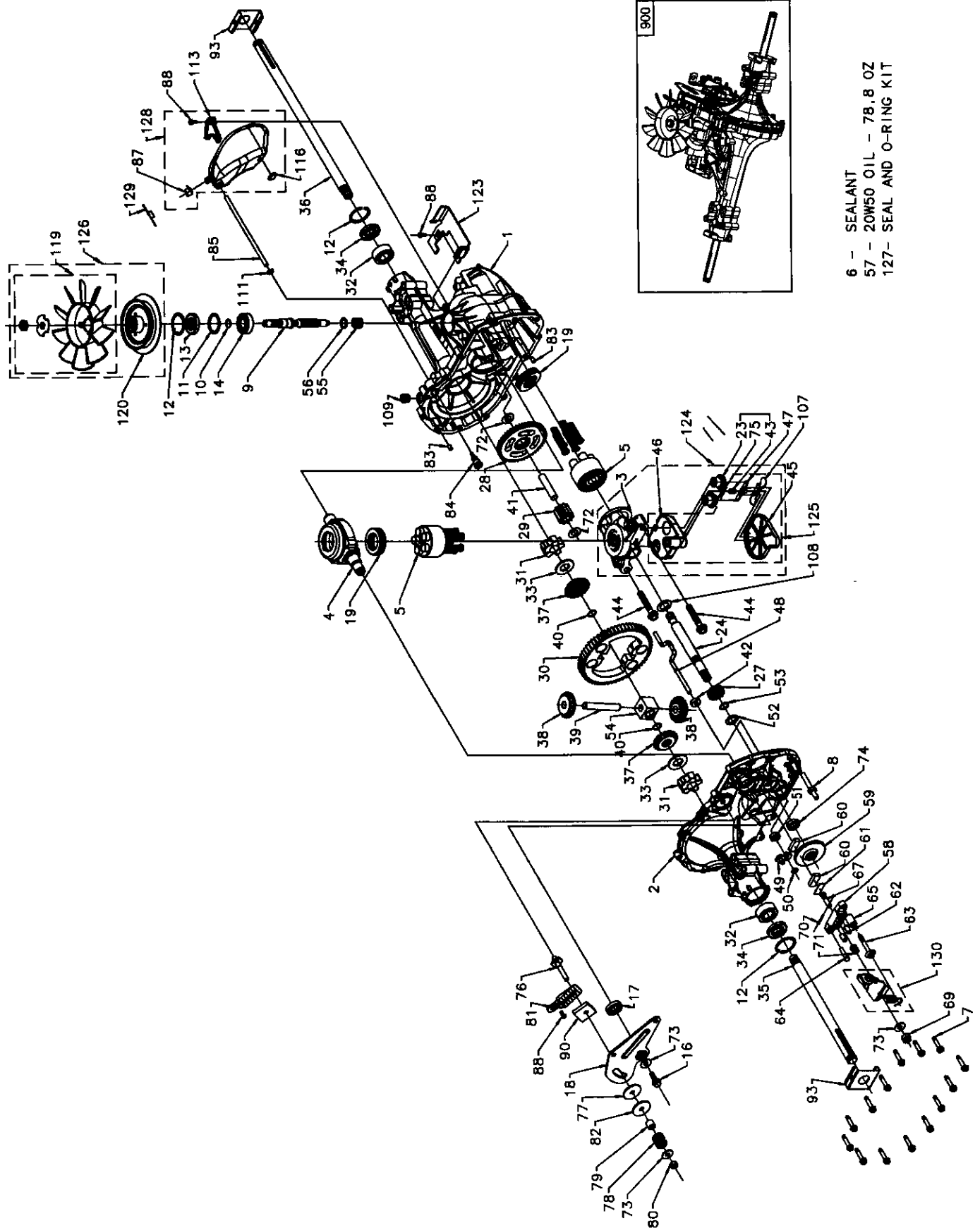

- 6 - SEALANT
- 57 - 20W50 OIL - 78.8 OZ
- 127- SEAL AND O-RING KIT

REPAIR PARTS

TRACTOR- -MODEL NO. 917. 277460

HYDRO GEAR TRANSAXLE - MODEL NUMBER 314-0510

KEY NO.	PART NO.	DESCRIPTION	KEY NO.	PART NO.	DESCRIPTION
1	170351	Kit, Main Housing Main Housing, Ma-	71	170417	Brake Spring
2	170352	Kit, Side Housing Side Housing, Ma-	72	170418	Washer (310-0750)
		chined Bushing .865 X .985 X .790	73	142884	Washer, Flat
		chined Bushing .865 X .985 X .790	74	170419	Seal, Oil
		Bushing .624 X .719 X .562	75	170420	Ass'y Check Plug
3	170353	Kit, Center Section Center Section, Ma-	76	170421	Bolt, Stud 5/16-24
		chined Bushing .707 X .788 X .591	77	170422	Puck, Friction
4	170354	Swashplate, Trunnion Machined	78	142969	Spring
5	169898	Kit, Cylinder Block (10cc) Block - Cylin-	79	142980	Spacer
		der Piston Spring, Compression	80	150778	Nut, Nylon Insert Hex Lock 5/16-24
		Washer Thrust	81	170423	Wedge, Friction
6	178322	Sealant Tube	82	170424	Clip, Washer
7	170356	Hexflange Screw 1/4-20 X 1.25	83	161168	Pin
8	170357	Stud, 5/16-24 Hex Double End	84	170425	Fitting, 5/16 X Sae 5/32 Tube
9	170358	Shaft, Input	85	170426	Hose, Expansion Tank
10	170359	Retaining Ring	87	173160	Cap, Vent
11	170360	Spacer	88	178334	Bolt, Self Tapping (BDR)
12	169870	Retaining Ring	90	170430	Puck, Inner Wedge
13	170361	Seal, Lip .67 X 1.58 X .276	93	170431	Spring Clip, Housing
14	173158	Bearing, Ball 6203 (BDR)	107	170432	Deflector
16	170362	Hex Flange Head Screw 1/4-20 X 1.25	108	170433	Washer, Motor Shaft .71ID X 1.15OD X
17	170363	Seal, Lip 18 X 32 X 7			.03 Thick
18	170364	Arm, Control	109	170434	Plug, Straight Thread 9/16-18
19	173159	Bearing, Thrust (10cc)	111	170435	O-ring .7 X .301 ID
23	170365	Check Plug Assembly	113	170437	Bracket, Support Expansion Tank
24	170366	Shaft Motor	119	191031	Kit, Fan - Washer - Nut
27	170367	Gear, Pinion, 13t			Fan, 7 In
28	170368	10t / 48t Gear			Hex Lock Nut 1/2-20 (Nylon Insert)
29	170369	Gear, 10t Jackshaft			Washer, Or Slotted, .53 X 1.63 X .06
30	170370	60t Bullgear	120	188312	Pulley
31	170371	Sleeve Bearing .75 X 1.75 X .625	123	178800	Belt Keeper
32	170389	Sleeve Bearing (Outboard) .75 X 1.575 X	124	170444	Kit, Center Section Filter Bypass
		.625			Center Section Machining
33	142991	Washer			Base Filter W/ Poppet
34	170390	Lip Seal, Axle Shaft			Check Plug Assembly, .027 Washer
35	170391	Shaft, Axle (Keyed, R.h.)			Check Plug Assembly, Washer
36	170392	Shaft, Axle (Keyed, L.h.)			Spring, Bypass
37	150792	Gear, Splined Diff. (210-1000 & 310-			Actuator, Bypass
		0750)			Deflector
38	150793	Gear, Miter Diff. (210-1000 & 310-0750)			Bottom, Filter
39	150809	Differential Shaft (310-0750)			Bushing, .707 X .788 X .591
40	170393	Retaining Ring	125	170445	Kit, Filter
41	170394	Pin, Jackshaft			Bottom, Filter
42	170395	Magnet, Ring			Spring, Bypass
43	170396	Spring, Bypass			Actuator, Bypass
44	150797	Bolt 3/8-24 X 2-1/2			Deflector
45	170397	Filter			Base, Filter W/ Poppet
46	170398	Base, Filter	126	191028	Kit, Fan/pulley
47	170399	Actuator, Bypass			Hex Jam 1/20-20 (Nylon Inser)
48	170400	Rod, Bypass Actuator			Washer, OD Slotted, .53 X 1.63 X .06
49	170401	Arm, Bypass			Fan, 7 In
50	170402	Retaining Ring .25 External			Pulley
51	170403	Seal, Lip .741 X .25 X .25	127	170447	Kit, Seal
52	170404	Washer, Flat 0.050" (210-1000)			Lip Seal .67 X 1.58 X .276
53	170405	Retaining Ring			Lip Seal 18 X 32 X 7
54	170406	Bearing, Center Block			Lip Seal .706 X 1.584 X .25
55	142977	Spring, Helical Compression			Lip Seal .741 X .250 X .250 Tc
56	142978	Washer, Block Thrust			Oil Seal .625 X 1.0 X .25
57	-- --	20W-50 Oil			O-ring .07 X .301 ID
58	142929	Kit, Brake Yoke	128	173165	Kit, Expansion Tank, Tank, Expansion
59	170408	Rotor, Brake			Cap, Vent Bolt, Self Tapping 10-32 X 1/2
60	142883	Brake Puck			Bracket, Support Expansion Tank
61	142882	Brake Puck Plate			Silicon Sponge 1/2 X 1/2 X 3/16
62	170409	Pin, Brake Actuating	129	191032	Cap, Expansion Tank Shipping
63	170410	Hfhcs 1/4-20 X 2 W/patch, Special	130	186352	Kit, Brake Arm And Spring Arm, Brake
		Flange			Spring, Brake Arm Bias Instruction Sheet
64	142892	Bolt, Nylok			
65	170411	Spacer, Brake Torsion Spring			
67	170413	Bolt, Square Head - Brake			
69	170415	Nut, Castle 5/16-24			
70	170416	Pin, Cotter 3/32x3/4			

NOTE: All component dimensions given in U.S. inches 1 inch = 25.4 mm

REPAIR PARTS

TRACTOR- -MODEL NO. 917. 277460

BRIGGS & STRATTON ENGINE - - MODEL NUMBER 445777, TYPE NUMBER 0352-E1

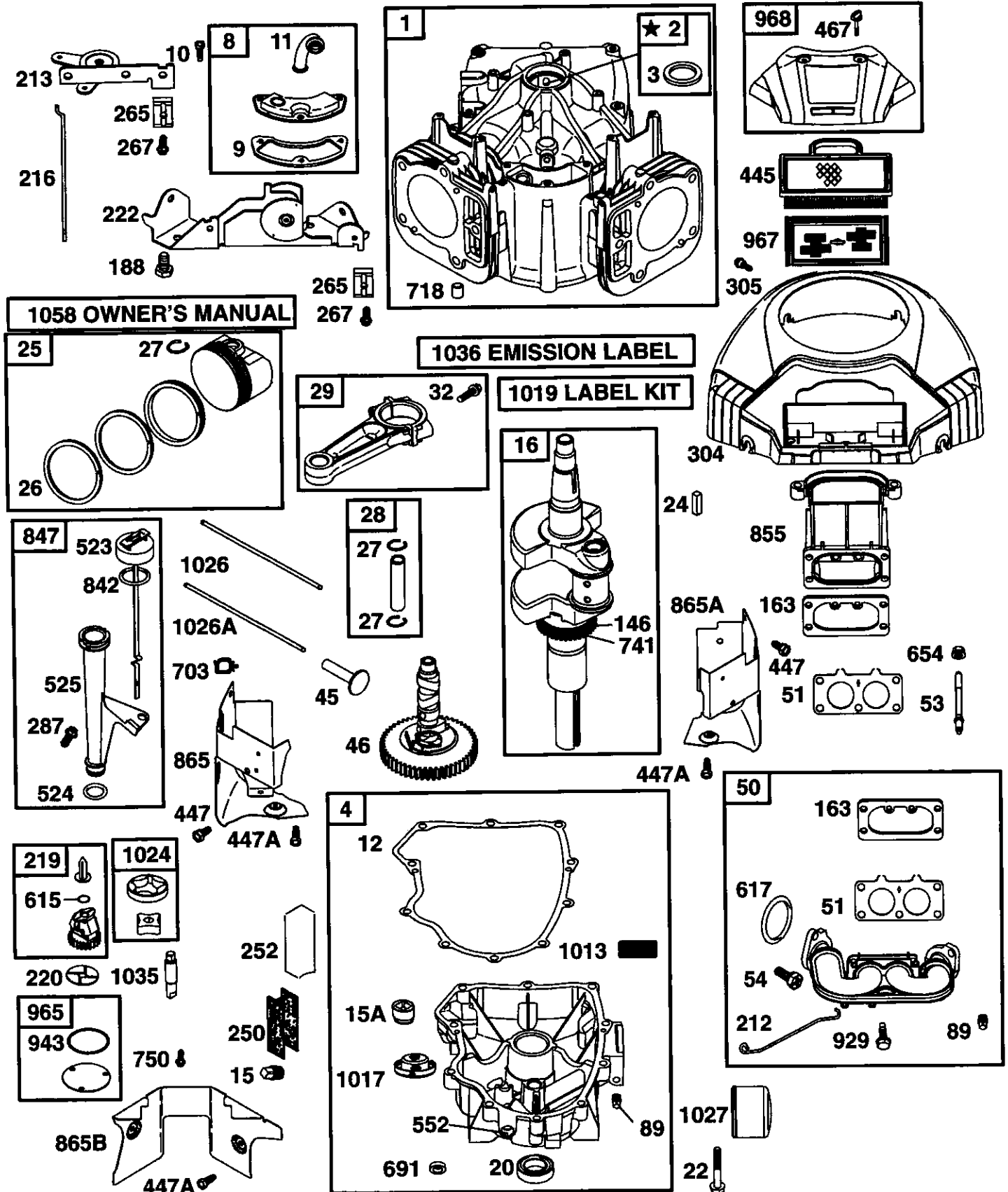

REPAIR PARTS

TRACTOR- -MODEL NO. 917. 277460

BRIGGS & STRATTON ENGINE - - MODEL NUMBER 445777, TYPE NUMBER 0352-E1

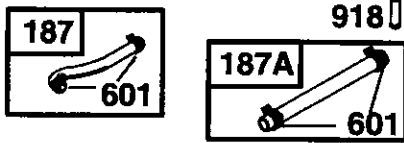
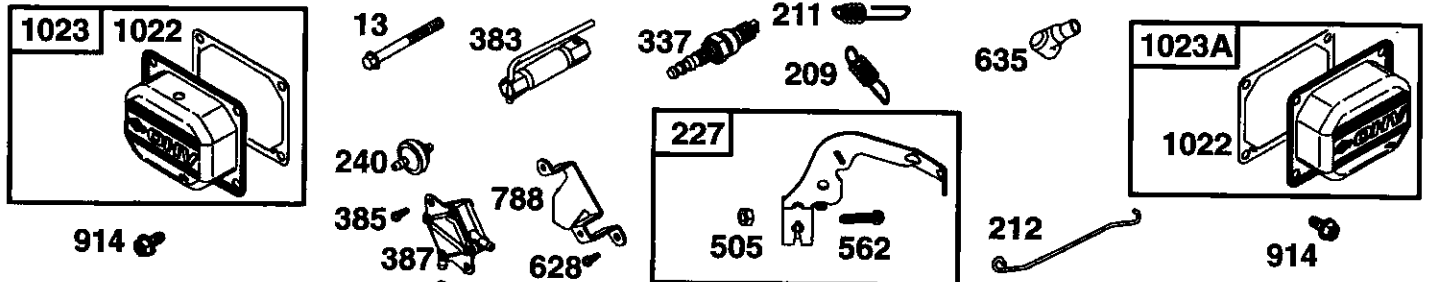
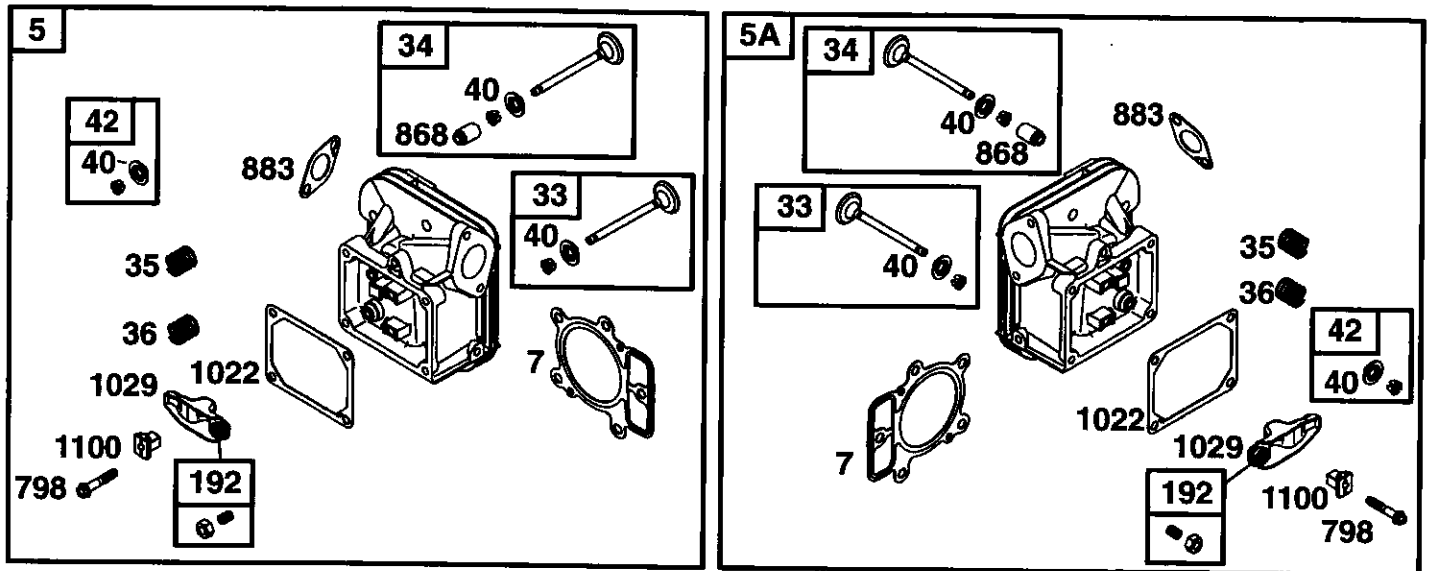

121 CARBURETOR OVERHAUL KIT

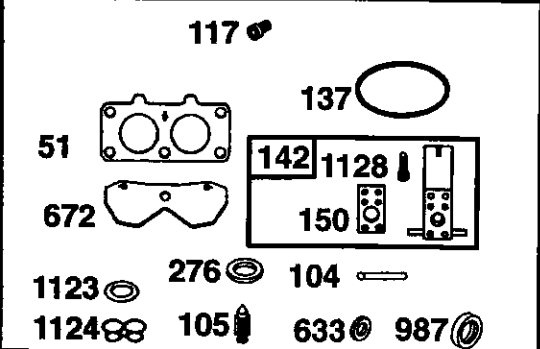

977 CARBURETOR GASKET SET

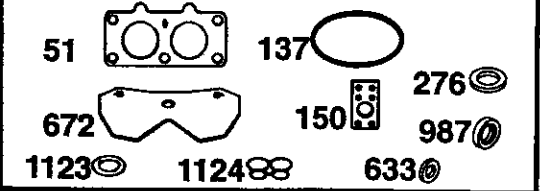

- 616
- 552
- 552A
- 742
- 404
- 552A
- 691

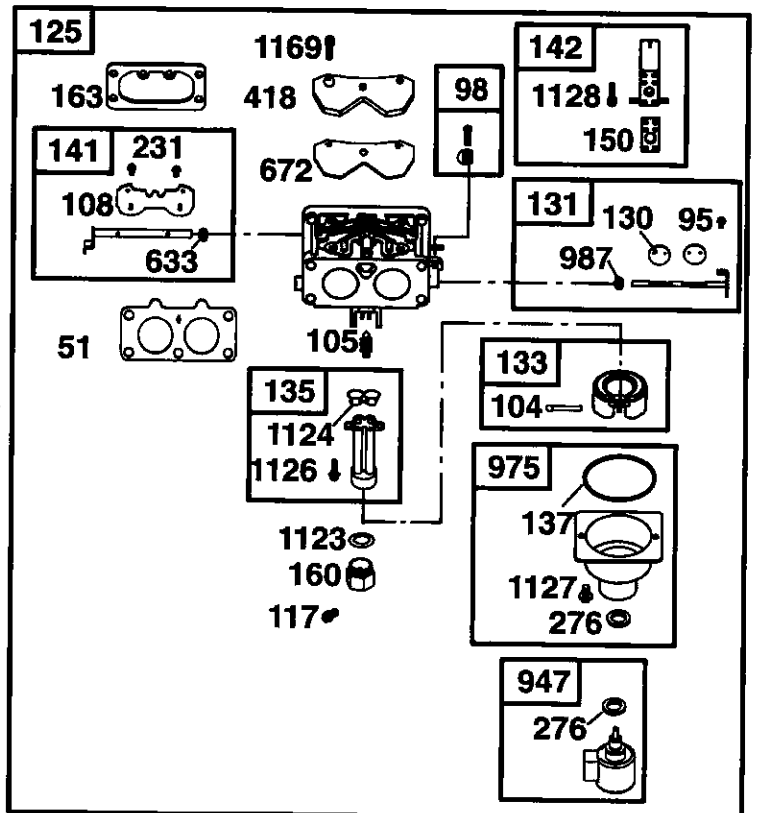

REPAIR PARTS

TRACTOR- -MODEL NO. 917. 277460
 BRIGGS & STRATTON ENGINE - - MODEL NUMBER 445777, TYPE NUMBER 0352-E1

1329 REPLACEMENT ENGINE

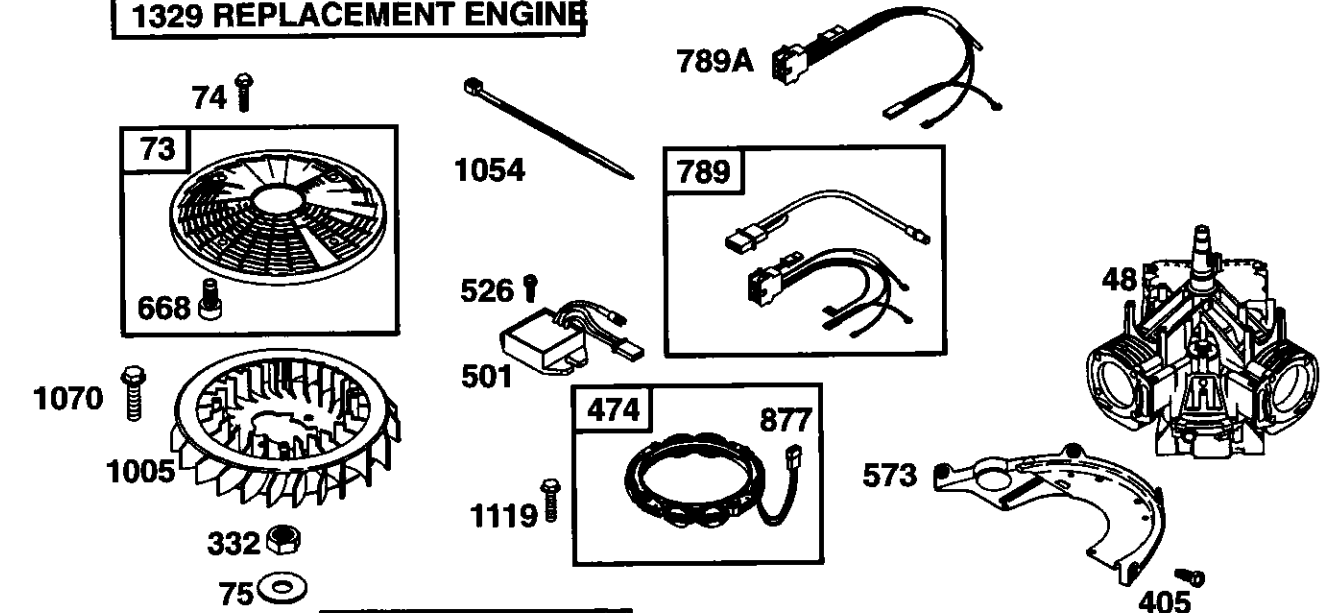

1330 REPAIR MANUAL

1095 VALVE GASKET SET

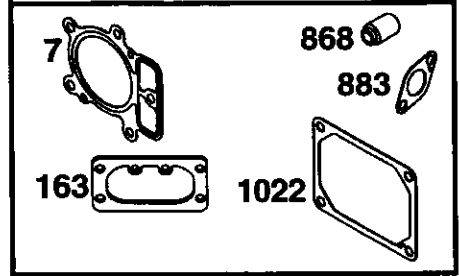

726

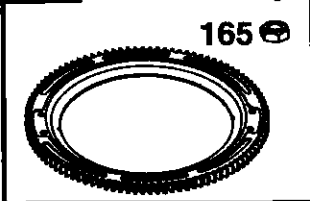

23

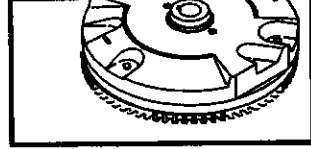

333

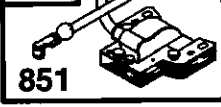

358 ENGINE GASKET SET

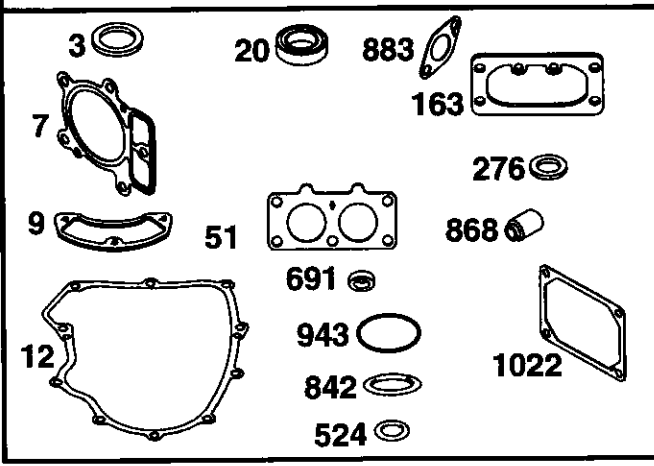

309

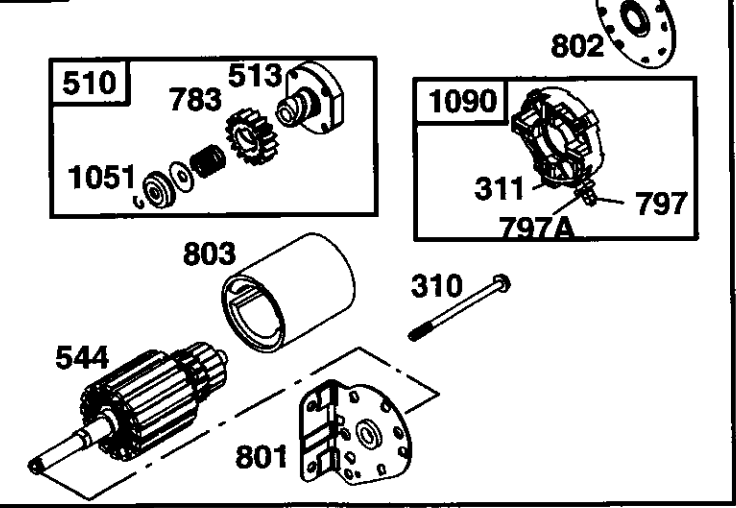

REPAIR PARTS

TRACTOR- -MODEL NO. 917. 277460

BRIGGS & STRATTON ENGINE - - MODEL NUMBER 445777, TYPE NUMBER 0352-E1

KEY NO.	PART NO.	DESCRIPTION	KEY NO.	PART NO.	DESCRIPTION
1	699753	Cylinder Assembly	133	499806	Float-Carburetor
2	499585	Kit-Bushing/Seal (Magneto Side)	135	499803	Tube-Fuel Transfer
3	391086	• Seal-Oil (Magneto Side)	137	690994	Ø‡ Gasket-Float Bowl
4	699747	Sump-Engine	141	499807	Kit-Choke Shaft
5	693998	Head-Cylinder (Cylinder 1)	142	499808	Ø Nozzle-Carburetor
5A	693999	Head-Cylinder (Cylinder 2)	146	690979	Key-Timing
7	693997	•+ Gasket-Cylinder Head	150	690995	Ø‡ Gasket-Nozzle
8	499601	Breather Assembly	160	690996	Retainer-Solenoid
9	690937	• Gasket-Breather	163	691001	•+ Gasket-Air Cleaner
10	690960	Screw (Breather Assembly)	165	693148	Nut (Ring Gear)
11	690942	Tube-Breather	187	691049	Line-Fuel
12	697227	• Gasket-Crankcase	187A	691050	Line-Fuel (Cut to Required Length)
13	690360	Screw (Cylinder Head)	188	690960	Screw (Control Bracket)
15	690946	Plug-Oil Drain	192	690083	Adjuster-Rocker Arm
15A	691680	Plug-Oil Drain	209	697674	Spring-Governor
16	699700	Crankshaft	211	691019	Spring-Governed Idle
20	690947	• Seal-Oil (PTO Side)	212	695238	Link-Governor
22	694966	Screw (Crankcase Cover)	213	691021	Bracket-Choke Control
23	691053	Flywheel	216	691022	Link-Choke
24	222698	Key-Flywheel	219	698231	Gear-Governor
25	694003	Piston Assembly (Standard)	220	690412	Washer (Governor Gear)
	694007	Piston Assembly (.020" Oversize)	222	698757	Bracket-Control
26	694004	Ring Set (Standard)	227	691048	Lever-Governor Control
	694008	Ring Set (.020" Oversize)	231	690718	Screw (Choke Valve)
27	690975	Lock-Piston Pin	240	691035	Filter-Fuel
28	690229	Pin-Piston (Standard)	250	690957	Retainer-Breather
29	499583	Rod-Connecting (Standard)	252	690956	Collector-Oil
32	690976	Screw (Connecting Rod)	265	691024	Clamp-Casing
33	499596	Valve-Exhaust	267	695134	Screw (Casing Clamp)
34	499597	Valve-Intake	276	690997	•Ø‡ Washer-Sealing
35	690963	Spring-Valve (Intake)	287	690960	Screw (Dipstick/Tube Assembly)
36	690963	Spring-Valve (Exhaust)	304	695277	Housing-Blower
40	690964	Retainer-Valve	305	691005	Screw (Blower Housing)
42	499586	Keeper-Valve	309	691262	Motor-Starter
45	690977	Tappet-Valve	310	691263	Screw (Starter Motor)
46	699748	Camshaft	311	497608	Brush Set
48	693893	Short Block	332	691059	Nut (Flywheel)
50	695241	Manifold-Intake	333	691060	Armature-Magneto
51	690950	•Ø‡ Gasket-Intake	334	691061	Screw (Magneto Armature)
53	690951	Stud (Carburetor)	337	691043	Spark Plug
54	695240	Screw (Intake Manifold)	358	694012	Gasket Set-Engine
73	691055	Screen-Rotating	363	691062	Puller-Flywheel
74	691057	Screw (Rotating Screen)	383	690966	Wrench-Spark Plug
75	691056	Washer (Flywheel)	385	690960	Screw (Fuel Pump)
89	690283	Plug-Oil	387	808656	Pump-Fuel
95	690718	Screw (Throttle Valve)	404	690442	Washer (Governor Crank)
98	499802	Kit-Idle Speed			
104	690984	Ø Pin-Float Hinge			
105	690985	Ø Valve-Float Needle			
108	690986	Valve-Choke			
117	690232	Ø Jet-Main (Standard)			
121	499811	Kit-Carburetor Overhaul			
125	499804	Carburetor			
130	690993	Valve-Throttle			
131	499805	Kit-Throttle Shaft			

- Included in Engine Gasket Set, Key. No. 358
- Ø Included in Carburetor Overhaul Kit, Key. No. 121
- ‡ Included in Carburetor Gasket Set, Key. No. 977
- + Included in Valve Overhaul Kit, Key. No. 1095

NOTE: All component dimensions given in U.S. inches 1 inch = 25.4 mm

REPAIR PARTS

TRACTOR- -MODEL NO. 917. 277460

BRIGGS & STRATTON ENGINE - - MODEL NUMBER 445777, TYPE NUMBER 0352-E1

KEY NO.	PART NO.	DESCRIPTION	KEY NO.	PART NO.	DESCRIPTION
405	697820	Screw (Back Plate)	877	399916	Wire/Connector-Alternator
418	690999	Plate-Carburetor	883	690970	*+ Gasket-Exhaust
445	499486	Filter-Air Cleaner Cartridge	914	691127	Screw (Rocker Arm Cover)
447	691003	Screw (Air Guide Cover)	918	694000	Hose-Vacuum
447A	690960	Screw (Air Guide Cover)	929	695239	Screw (Choke Control Bracket)
467	691008	Knob-Air Cleaner	943	690589	• Seal-O Ring (Oil Pump Cover)
474	696458	Alternator	947	499809	Solenoid-Fuel
501	691185	Regulator	965	499613	Cover-Oil Pump
505	691029	Nut (Governor Control Lever)	967	273638	Filter-Pre Cleaner
510	497606	Drive-Starter	968	499788	Cover-Air Cleaner
513	692024	Clutch-Drive	975	499810	Bowl-Float
523	691036	Dipstick	977	499812	Gasket Set-Carburetor
524	691032	• Seal-O Ring (Dipstick Tube)	987	691000	Ø‡ Seal-Throttle Shaft
525	691037	Tube-Dipstick	1005	499603	Fan-Flywheel
526	690960	Screw (Regulator)	1013	690954	Nipple-Oil Filter
544		Armature-Starter (Serviced by 691262 Starter Motor Only)	1017	690770	Screen-Oil Pump
			1019	693995	Kit-Label
552	690552	Bushing-Governor Crank	1022	690971	*+ Gasket-Rocker Cover
552A	690553	Bushing-Governor Crank	1023	499599	Cover-Rocker Arm (Cylinder 1)
562	690311	Bolt (Governor Control Lever)	1023A	499600	Cover-Rocker Arm (Cylinder 2)
573	691009	Plate-Back	1024	499054	Pump-Oil
601	95162	Clamp-Hose	1026	690981	Rod-Push (Steel)
615	698290	Retainer-Governor Shaft	1026A	690982	Rod-Push (Aluminum)
616	691045	Crank-Governor	1027	492932	Filter-Oil
617	691917	Seal-O Ring (Intake Manifold)	1029	690972	Arm-Rocker
628	690960	Screw (Fuel Pump Bracket)	1035	691042	Shaft-Pump
633	690998	Ø‡ Seal-Choke/Throttle Shaft	1036	695704	Label-Emission
635	66538	Boot-Sparkplug	1051	691265	Ring-Retaining
654	690958	Nut (Carburetor)	1054	280275	Cable-Tie
668	691215	Spacer	1058	275475	Owner's Manual
672	690234	Ø‡ Gasket-Carburetor Plate	1070	690372	Screw (Flywheel Fan)
691	690657	• Seal-Governor Shaft	1090	691293	Retainer-Brush
695	693149	Screw (Ring Gear)	1095	694013	Set-Valve Gasket
697	690372	Screw (Drive Cap)	1100	690973	Pivot-Rocker Arm
703	691010	Clip	1119	691183	Screw (Alternator)
718	690959	Pin-Locating	1123	690987	Ø‡ Seal-O Ring (Solenoid Retainer)
726	499612	Gear-Ring	1124	690988	Ø‡ Seal-O Ring (Fuel Transfer Tube)
741	690980	Gear-Timing	1126	690991	Screw (Fuel Transfer Tube)
742	690328	Retainer-E Ring	1127	690992	Screw (Float Bowl)
750	696999	Screw (Oil Pump Cover)	1128	690990	Ø Screw (Carburetor Nozzle)
783	693058	Gear-Pinion	1169	693140	Screw (Carburetor Cover Plate)
788	691039	Bracket-Fuel Pump	1329	445777-0027	Replacement Engine (If the original engine is equipped with a six pin wiring harness, transfer to the replacement engine)(Transfer Governor Spring to the replacement engine)(Transfer muffler and/or spark arrester assembly from the original engine if suitable for additional service or add new parts as required)
789	698330	Harness-Wiring			
789A	696576	Harness-Wiring			
797	691029	Nut (Brush Retainer)			
797A	693167	Nut (Brush Retainer)			
798	697890	Screw (Rocker Arm)			
801	691283	Cap-Drive			
802	691286	Cap-End			
803		Housing-Starter (Serviced by 691262 Starter Motor Only)			
842	691031	• Seal-O Ring (Dipstick)			
847	499602	Assembly-Dipstick/Tube	1330	273521	Repair Manual
851	493880	Terminal-Sparkplug			
855	691011	Adapter-Air Cleaner			
865	691012	Cover-Air Guide (Cylinder 1)			
865A	691014	Cover-Air Guide (Cylinder 2)			
865B	691015	Cover-Air Guide			
868	690968	*+ Seal-Valve			

NOTE: All component dimensions given in U.S. inches 1 inch = 25.4 mm