

REPAIR PARTS MANUAL
MODEL NO. 277500
Lawn Tractor

CRAFTSMAN®

HOW TO USE THIS MANUAL

This manual is designed to provide the customer with a means to identify the parts on his/her tractor when ordering repair parts. The illustrations may or may not represent the actual assemblies; therefore, it is not recommended to use this manual as a guide to assemble or disassemble the tractor. Some hardware and parts are drawn larger in order to more readily identify them.

Each tractor has its own model number.

The model number for your tractor can be found on the fender under the seat.

When ordering parts, always give the following information:

- Product - "Tractor"
- Model Number - "277500"
- Part Number
- Part Description

TABLE OF CONTENTS

SCHEMATIC	3
ELECTRICAL.....	4-5
CHASSIS.....	6-7
DRIVE.....	8-9
STEERING	10-11
SEAT	12
DECALS.....	13
ENGINE.....	14
MOWER LIFT	15
MOWER DECK	16-17
TRANSAXLE.....	18-19
ENGINE BREAKDOWN.....	20-23
WARRANTY	24

TRACTOR- -MODEL NO. 917. 277500

SCHEMATIC

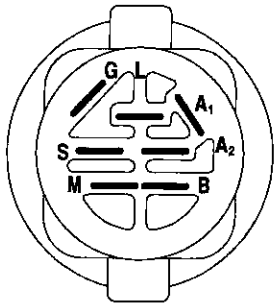
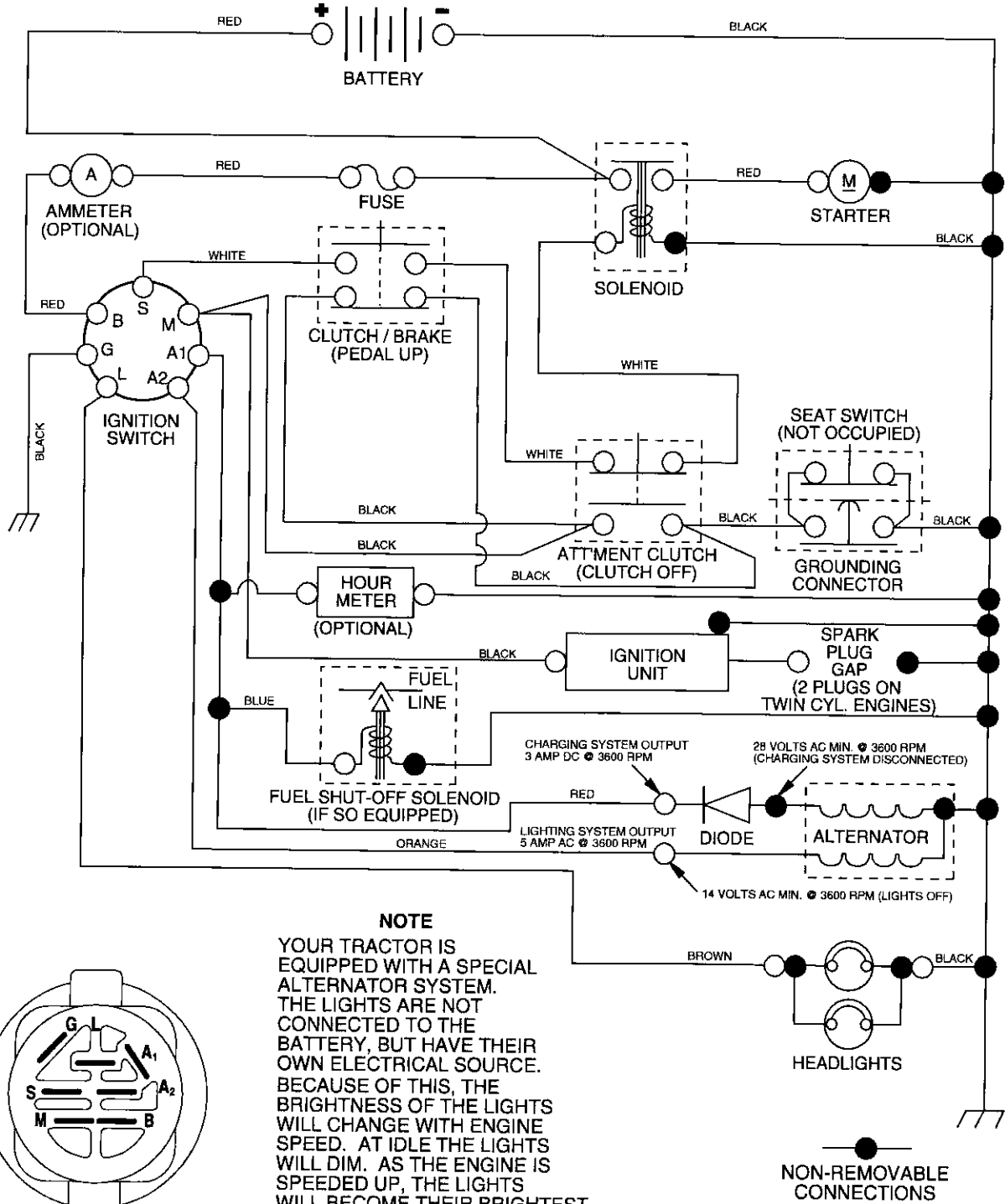

IGNITION SWITCH

POSITION	CIRCUIT	"MAKE"
OFF	M+G+A1	NONE
RUN/LIGHT	B+A1	A2+L
RUN	B+A1	NONE
START	B + S + A1	NONE

WIRING INSULATED CLIPS

NOTE: IF WIRING INSULATED CLIPS WERE REMOVED FOR SERVICING OF UNIT, THEY SHOULD BE REPLACED TO PROPERLY SECURE YOUR WIRING.

02363

REPAIR PARTS

TRACTOR- -MODEL NO. 917. 277500

ELECTRICAL

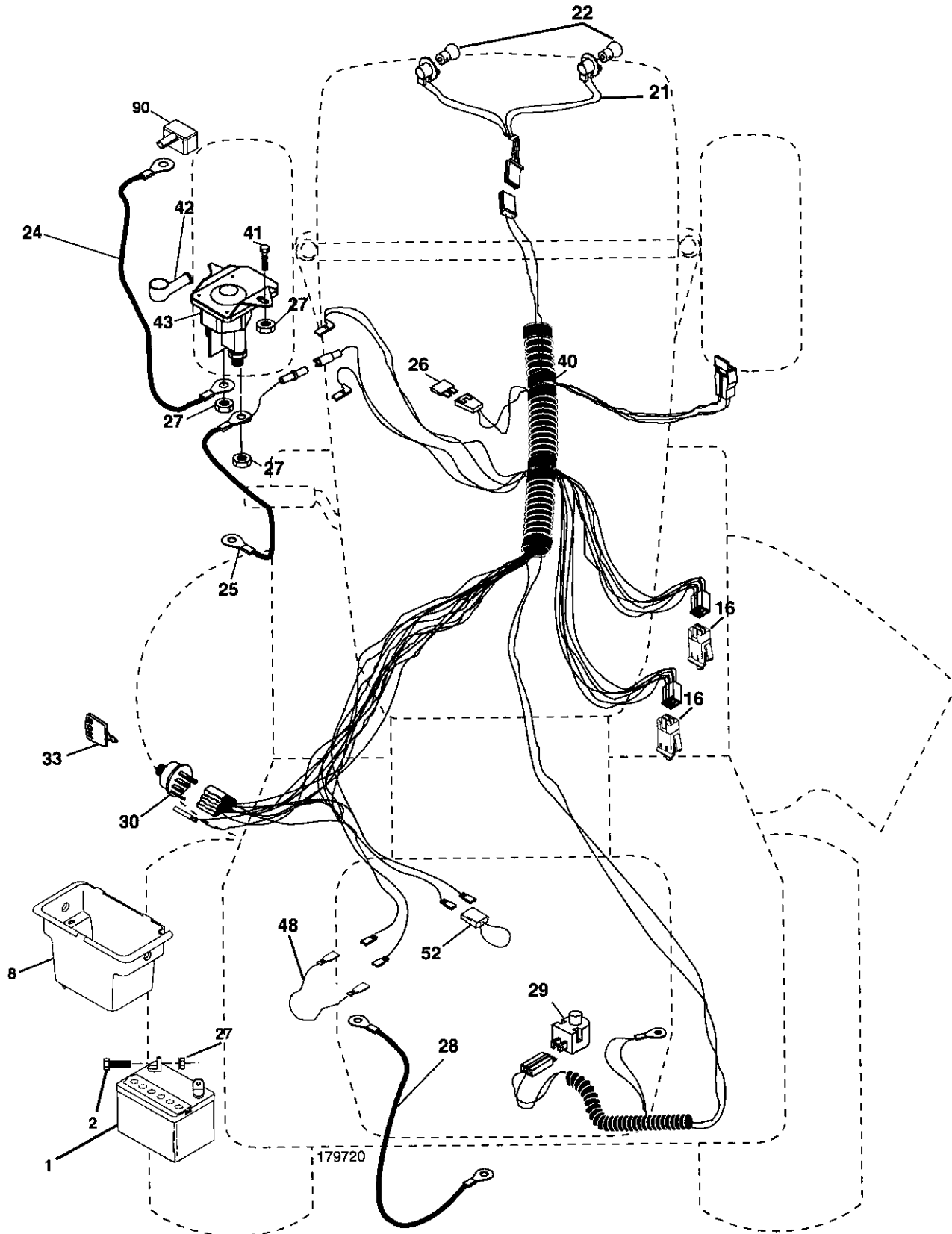

REPAIR PARTS

TRACTOR- -MODEL NO. 917. 277500

ELECTRICAL

KEY NO.	PART NO.	DESCRIPTION
1	163465	Battery
2	74760412	Bolt Hex Hd 1/4-20 unc x 3/4
8	176689	Box Battery
16	176138	Switch, Interlock
21	183759	Harness Asm Light W/4152j
22	4152J	Bulb Light #1156
24	4799J	Cable Battery 6 Ga. 11" red
25	146147	Cable Battery
26	175158	Fuse
27	73510400	Nut Keps Hex 1/4-20 Unc
28	4207J	Cable Ground 6 Ga. 12" black
29	121305X	Switch Seat
30	175556	Switch Ign
33	140403	Key Ign
40	179720	Harness Ign
41	71110408	Bolt Blk. Fin Hex 1/4-20 unc x 1/2
42	131563	Cover Terminal Red
43	192507	Solenoid
48	140844	Adapter Ammeter
52	141940	Protection Wire Loop
90	180449	Cover Terminal

NOTE: All component dimensions give in U.S. inches
1 inch = 25.4 mm

REPAIR PARTS

TRACTOR- -MODEL NO. 917. 277500

CHASSIS AND ENCLOSURES

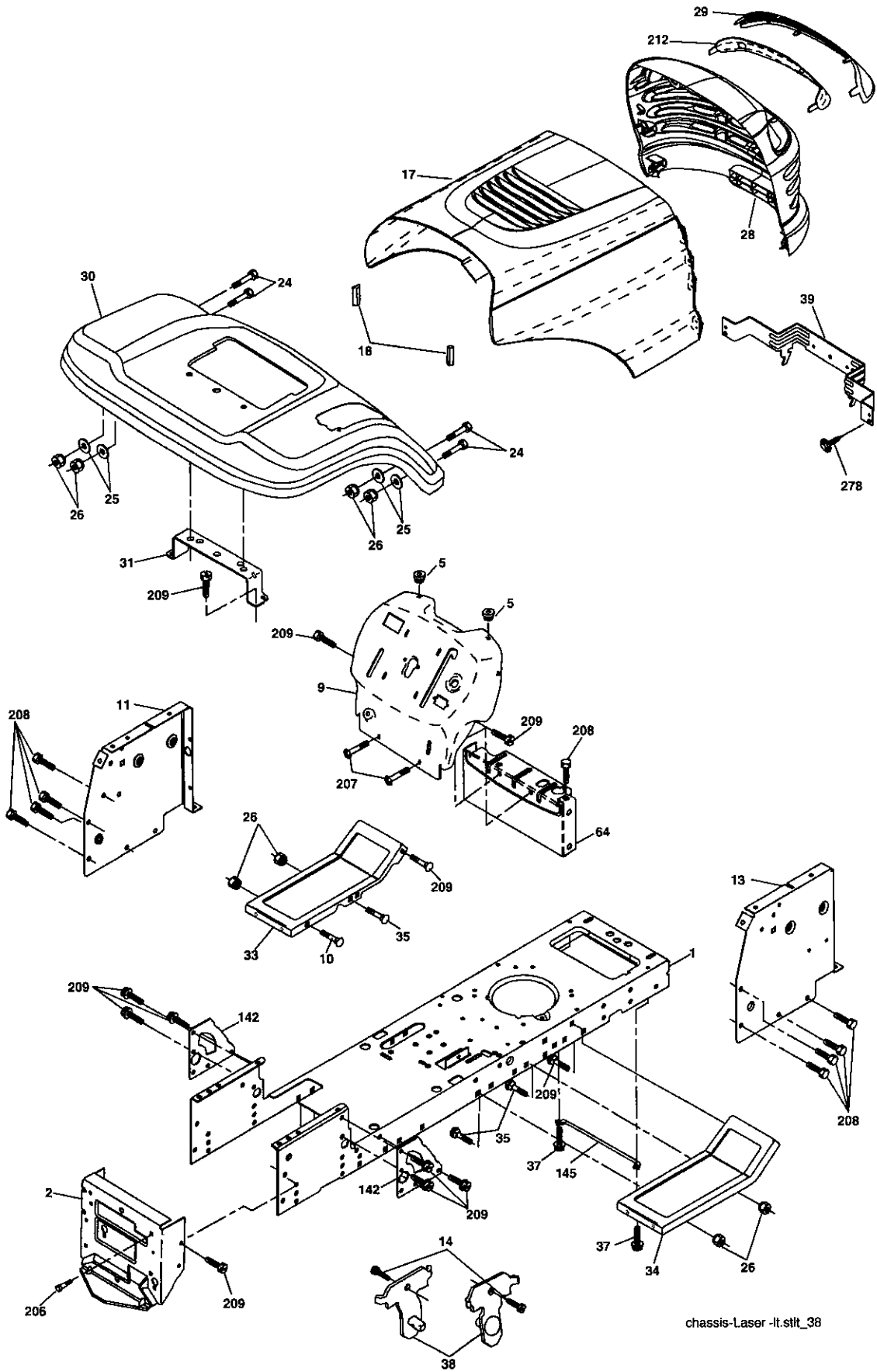

chassis-Laser -It.stit_38

REPAIR PARTS

TRACTOR- -MODEL NO. 917. 277500

CHASSIS AND ENCLOSURES

KEY NO.	PART NO.	DESCRIPTION
1	174619	Chassis
2	176554	Drawbar
5	155272	Bumper Hood/Dash
9	193510X013	Dash
10	STD533710	Bolt, Carriage 3/8-16 x 3/4
11	174996	Panel, Dash, L.H.
13	172105X010	Panel, Dash, R.H.
14	17490608	Screw Thdrol 3/8-16 x 1/2
17	185682X613	Hood Assembly
18	184921	Bumper Hood
24	STD523710	Bolt Fin. Hex 3/8-16 x 1
25	19131312	Washer 13/32 x 13/16 x 12 Ga.
26	STD541437	Nut
28	193258	Grille/Lens Asm. (Includes Key Nos. 29 and 212)
29	174332X599	Lens
30	192526X613	Fender
31	136619	Bracket, Fender Support
33	179716X613	Footrest LH
34	179717X613	Footrest RH
35	STD533707	Bolt Rdhd Sht Sqnk 3/8-16 x 3/4
37	17490508	Screw Thdrol 5/16-18 x 1/2
38	175710	Pivot Bracket Assembly, Rear
39	174714	Bracket Pivot Laser Lt
64	154798	Dash Lower STLT
142	175702	Plate Reinforcement STLT
145	156524	Rod Pivot Chassis/Hood
206	170165	Bolt Shoulder 5/16-18 TT
207	17670508	Screw Thdrol 5/16-18 x 1/2 Tytt
208	17670608	Screw Thdrol 3/8-16 x 1/2
209	17000612	Screw Hexwsh Thdr 3/8-16 x 3/4
212	175143	Insert Lens Reflective
278	191611	Screw 10 x 3/4 Single Lead-Hex
--	5479J	Plug, Button
--	187801	Plug Plastic Dome
--	193640X428	Plug Switch Light

NOTE: All component dimensions given in U.S. inches
1 inch = 25.4 mm

REPAIR PARTS

TRACTOR- -MODEL NO. 917. 277500

DRIVE

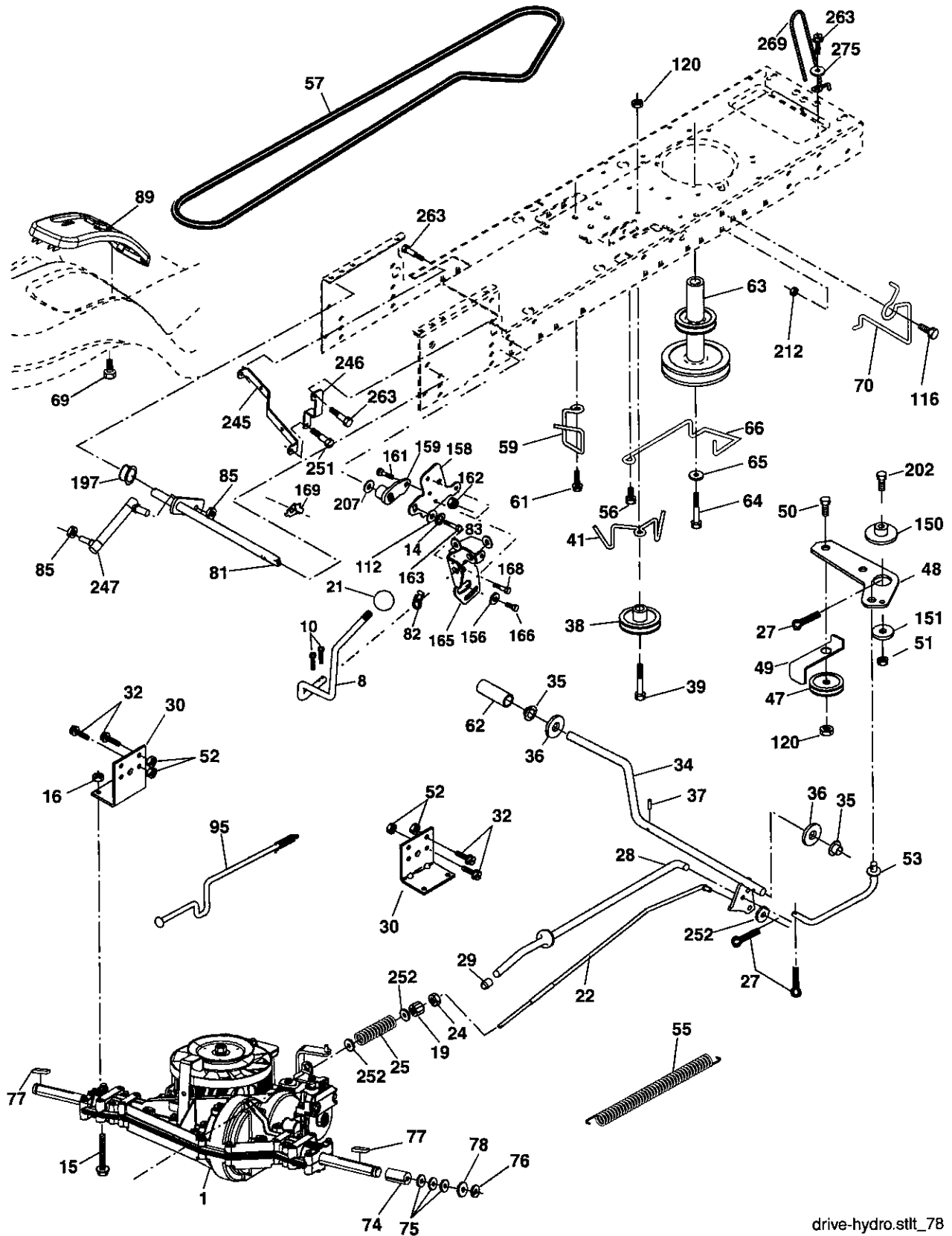

drive-hydro.stlt_78

REPAIR PARTS

TRACTOR- -MODEL NO. 917. 277500

DRIVE

KEY NO.	PART NO.	DESCRIPTION	KEY NO.	PART NO.	DESCRIPTION
1	-----	Transaxle Peerless LTH2000 (See Breakdown)	70	180218	Keeper Belt Engine
8	192706	Rod Shift Fender	74	137057	Spacer
10	STD561210	Pin Cotter 1/8 x 1 CAD	75	121749X	Washer 25/32 x 1-1/4 x 16 Ga.
14	10040400	Washer Lock Hvy Helical	76	STD581075	E-Ring
15	74490544	Bolt Hex FLGHD 5/16-18 Gr.5	77	123583X	Key, Square
16	STD541431	Nut Lock Hex W/Ins. 5/16-18 unc	78	121748X	Washer 25/32 x 1-5/8 x 16 Ga.
19	STD541437	Nut Lock Hex W/Wsh 3/8-16 unc	81	178140	Shaft Asm Cross Tapered
21	130564	Knob	82	165711	Spring Torsion
22	178141	Rod, Brake	83	19171216	Washer 17/32 x 3/4 x 16 Ga.
24	73350600	Nut, Hex Jam 3/8-16 unc	85	150360	Nut Lock Center 1/4-28 FNTHD
25	106888X	Spring, Brake Rod	89	192056X428	Console, Shift
27	STD561210	Pin Cotter 1/8 x 3/4 CAD.	95	178134	Disconnect Asm Rod Bypas LTH
28	175765	Rod, Parking Brake	112	19091210	Washer 9/32 x 3/4 x 10 Ga.
29	71673	Cap, Parking Brake	116	72140608	Bolt Rdhd Sqneck 3/8-16 x 1
30	174973	Bracket, Transaxle	120	73900600	Nut Lock Flg 3/8-16
32	74760512	Bolt Hex Hd 5/16-18 unc x 3/4	150	175456	Spacer Retainer
34	175578	Shaft, Foot Pedal	151	19133210	Washer 13/32 x 2 x 10 Ga.
35	120183X	Bearing, Nylon	156	166002	Washer Srrted 5/16 ID x 1.125
36	19211616	Washer	158	165589	Bracket Shift Mount
37	1572H	Pin, Roll	159	183900	Hub Shift
38	179114	Pulley, Composite	161	72140406	Bolt Rdhd Sqnk 1/4-20 x 3/4 Gr. 5
39	72110622	Bolt Rdhd 3/8-16 unc x 2-3/4 Gr. 5	162	73680400	Nut Crownlock 1/4-20 unc
41	175556	Keeper, Belt Idler	163	74780416	Bolt Hex Fin 1/4-20 unc x 1 Gr. 5
47	127783	Pulley, Idler, V-Groove	165	165623	Bracket Pivot Lever
48	154407	Bellcrank, Clutch	166	17490510	Screw 5/16-18 x 5/8
49	123205X	Retainer, Belt	168	165492	Bolt Shoulder 5/16-18 x .561
50	72110612	Bolt Carr Sh 3/8-16 x 1-1/2 Gr 5	169	165580	Plate Fastening
51	STD541437	Nut Crownlock 3/8-16 unc	197	169613	Nyliner Snap-In 5/8"ID
52	STD541431	Nut, Crownlock 5/16-18 unc	202	72110614	Bolt Carr Sh 3/8-16 x 1-3/4 Gr.5
53	105710X	Link, Clutch	207	169593	Washer Nyl
55	105709X	Spring, Return, Clutch	212	145212	Nut Hex Flange Lock
56	17060620	Screw 3/8-16 x 1-1/4	245	178122	Strap Torque Lh LTH2000
57	178138	V-Belt	246	178121	Strap Torque Rh LTH2000
59	169691	Keeper, Center Span	247	181463	Link Shift Transaxle LTH2000
61	17120614	Screw 3/8-16 x .875	251	17060516	Screw 5/16-18 x 1
62	8883R	Cover, Pedal	252	19131616	Washer 13/32 x 1 x 16 Ga.
63	180219	Pulley, Engine	263	17000612	Screw Hex Wsh Thdr 3/8-16 x 3/4
64	173937	Bolt Hex 7/16-20 x 4 Gr. 5	269	182402	Guard Muffler
65	STD551143	Washer	275	19131614	Washer 13/32 x 1 x 14 Ga.
66	154778	Keeper Belt Engine Hydro			
69	142432	Screw Hex Wsh Hi-Lo 1/4-1/2 unc			

NOTE: All component dimensions given in U.S. inches
1 inch = 25.4 mm

REPAIR PARTS

TRACTOR- -MODEL NO. 917. 277500

STEERING ASSEMBLY

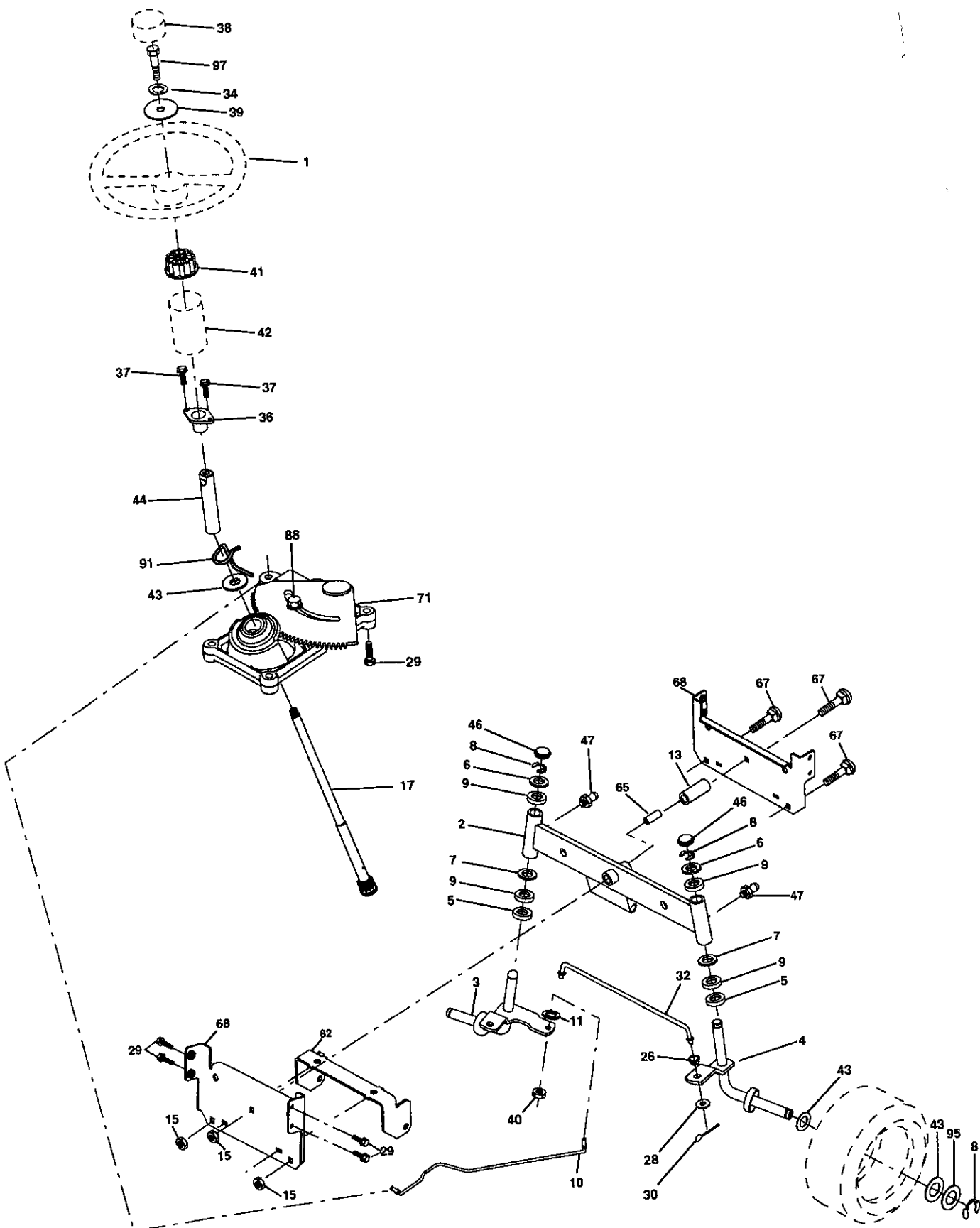

steering_pl.lt_58

REPAIR PARTS

TRACTOR- -MODEL NO. 917. 277500

STEERING ASSEMBLY

KEY NO.	PART NO.	DESCRIPTION
1	186780	Steering Wheel
2	175131	Axle Assembly
3	169840	Spindle Assembly, L.H.
4	169839	Spindle Assembly, R.H.
5	6266H	Washer Thrust
6	121748X	Washer 25/32 x 1-5/8 x 16 Ga.
7	19272016	Washer 27/32 x 1-1/4 x 16 Ga.
8	12000029	Ring, Klip
9	3366R	Washer Thrust
10	175121	Draglink
11	STD551137	Washer, Lock
13	136518	Spacer Bearing Axle Front
15	145212	Nut, Hex Flange Lock
17	190753	Shaft, Steering
26	126847X	Bushing, Link, Drag
28	19131416	Washer 13/32 x 7/8 x 16 Ga.
29	17000612	Screw 3/8-16 x 3/4
30	STD561210	Pin Cotter
32	192757	Rod, Tie
34	10040500	Washer Lock Hvy. Hlcl Spr 5/16
36	155099	Bushing, Steering
37	152927	Screw
38	186781	Insert, Steering Wheel
39	19113812	Washer 11/32 x 2-3/8 12 Ga.
40	STD541537	Nut Lock Center 3/8-24 unf
41	186737	Adaptor, Steering Wheel
42	145054X428	Boot, Steering Shaft
43	121749X	Washer 25/32 x 1-1/4 x 16 Ga.
44	190752	Extension Shaft Steering
46	121232X	Cap, Spindle
47	183226	Fitting Grease
65	160367	Spacer Brace Axle
67	72110618	Bolt RDHD Sqnk 3/8-16 x 2-1/4
68	169827	Axle, Brace
71	175146	Steering Asm.
82	169835	Bracket Susp. Chassis Front
88	175118	Bolt Shoulder 7/16-20 unc
91	175553	Clip Steering
95	188967	Washer Hardened
97	74780564	Bolt 5/16-18 unc x 4 Gr. 5

NOTE: All component dimensions given in U.S. inches
1 inch = 25.4 mm

REPAIR PARTS

TRACTOR- -MODEL NO. 917. 277500

SEAT ASSEMBLY

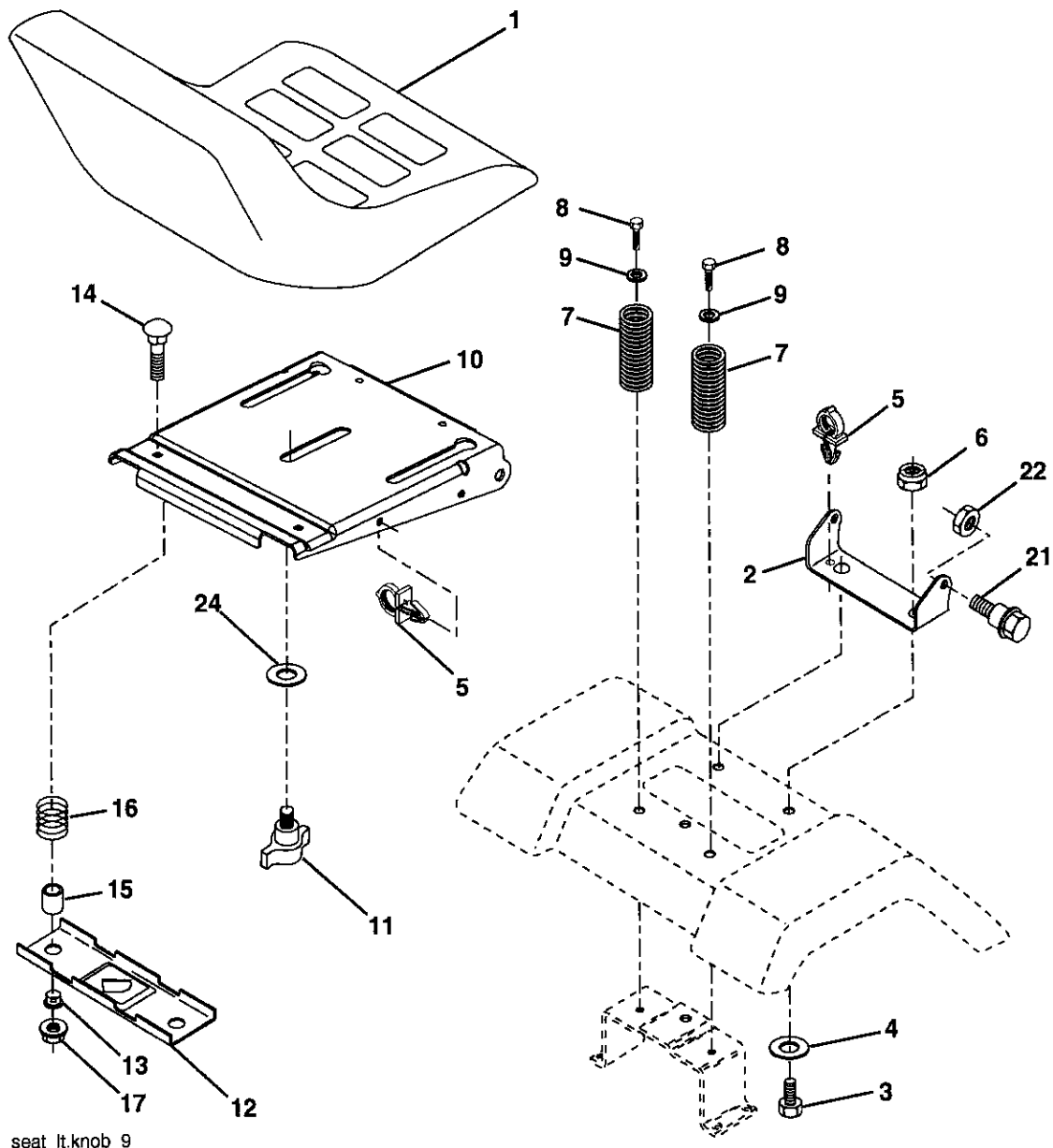

seat_ft.knob_9

KEY NO.	PART NO.	DESCRIPTION	KEY NO.	PART NO.	DESCRIPTION
1	188716	Seat	13	121248X	Bushing Snap Blk Nyl 50 Id
2	180166	Bracket Pnt Pivot Seat (blk)	14	72050412	Bolt Rdhd Sht Nk 1/4-20 x 1-1/2
3	71110616	Bolt Fin Hex 3/8-16 unc x 1	15	134300	Spacer Split 28 x 96 Zinc
4	19131610	Washer 13/32 x 3/4 x 10 Ga.	16	121250X	Spring Cprsn 1 27 Blk Pnt
5	145006	Clip Push In Hinged	17	123976X	Nut Lock 1/4 Lge Flg Gr. 5 Zinc
6	STD541437	Nut Hex Lock w/Ins 3/8-16 unc	21	171852	Bolt Shoulder 5/16-18 unc-2A
7	124181X	Spring Seat Cprsn 2 250 Blk Zi	22	STD541431	Nut Hex Lock w/Ins 5/16-18
8	17000616	Screw 3/8-16 x 1	24	19171912	Washer 17/32 x 1-3/16 x 12 Ga.
9	19131614	Washer 13/32 x 1 x 14 Ga.			
10	180186	Pan Pnt Seat (blk)			
11	166369	Knob Seat Adj Wingnut			
12	121246X	Bracket Mounting Switch			

NOTE: All component dimensions given in U.S. inches
1 inch = 25.4 mm

REPAIR PARTS

TRACTOR- -MODEL NO. 917. 277500

DECALS

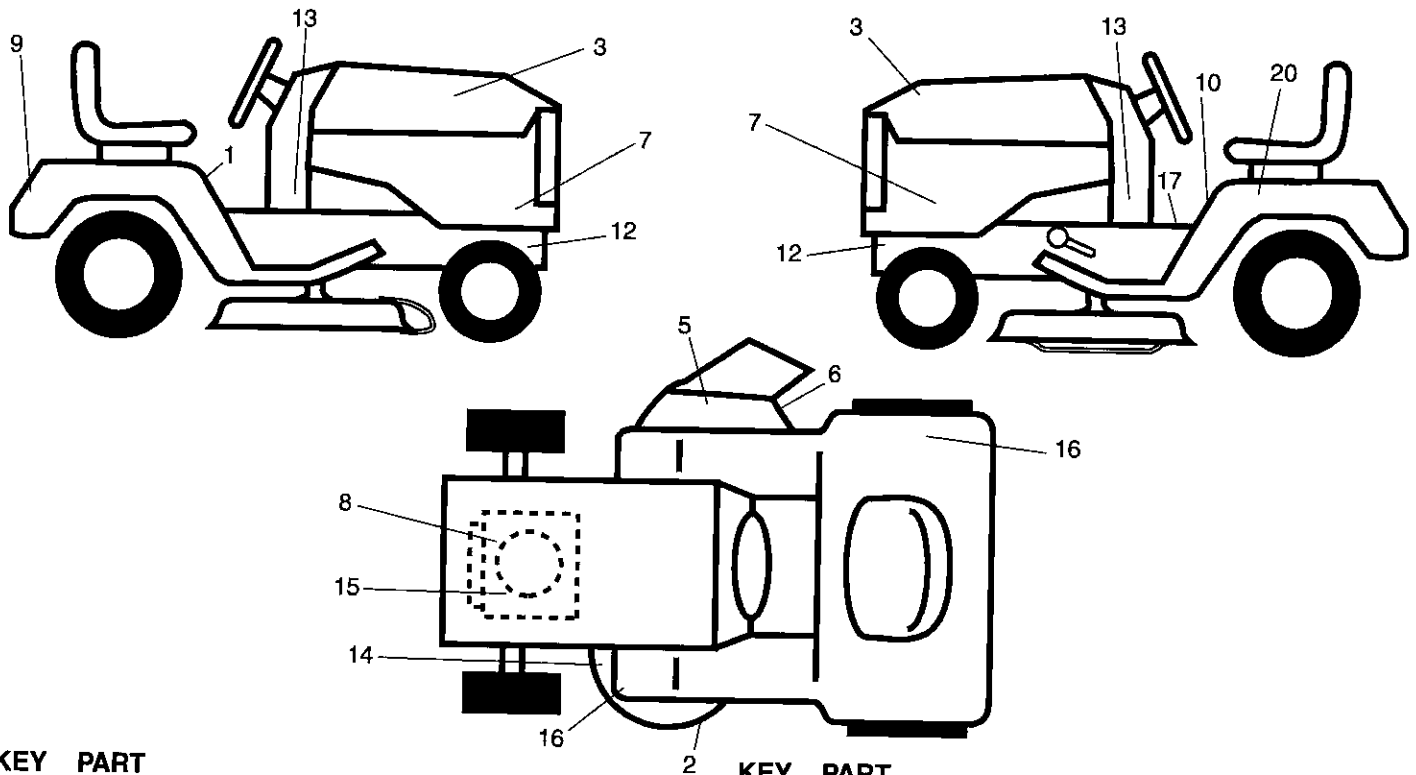

KEY NO.	PART NO.	DESCRIPTION
1	140837	Decal, Saddle Brake Parking
2	136832	Decal, V-Belt Sch.
3	196132	Decal, Hood, R.H.
5	182166	Decal, Cutfinger
6	196357	Decal, Defl. Wrn. Sym
7	193545	Decal, Hood Side
8	196841	Decal, Warning Eng. Sym.
9	186282	Decal, Fender, Craftsman
10	159737	Decal, Clutch/Brake
12	159736	Decal, Chassis Hot Muffler
13	189276	Decal, Dash Panel
14	197490	Decal, V-Belt Schematic

KEY NO.	PART NO.	DESCRIPTION
15	189244	Decal, Engine
16	180432	Decal, Fender DB/CE
17	145498	Decal, Read Owner's Manual
20	145005	Decal, Battery Dngr/Psn Eng
--	138311	Decal, Lift Handle
--	178392	Decal, Disconnect
--	162598	Decal, Load Limit
--	179768X428	Pad, Footrest LH STLT
--	179769X428	Pad, Footrest RH STLT
--	197570	Manual, Operator's (Euro)
--	197571	Manual, Operator's (Scand)
--	197572	Manual, Parts

WHEELS & TIRES

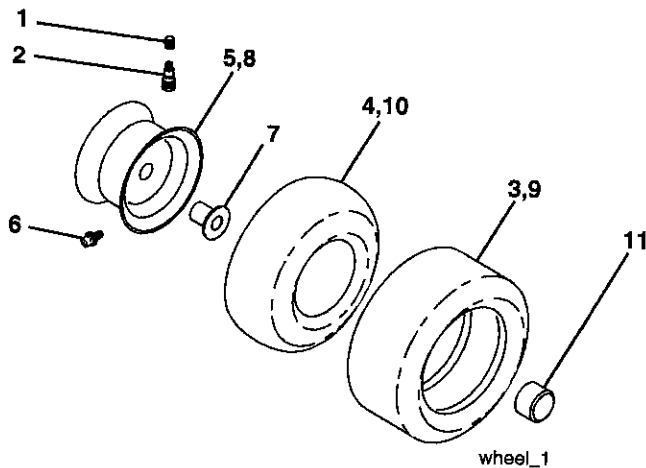

KEY NO.	PART NO.	DESCRIPTION
1	59192	Cap Value Tire
2	65139	Stem Value
3	106222X	Tire F Ts 15 x 6.0 - 6 Service
4	59904	Tube Inner Front #35060
5	106732X624	Rim Asm 6" front White Service
6	278H	Fitting Grease
7	9040H	Bearing Flange
8	106108X624	Rim Asm 8" rear White Service
9	124635X	Tire R Ts 18 x 8 5-8 Service
10	7152J	Tube Rear 9.5 x 8 Service
11	104757X428	Cap Axle Bik 1.50 x 1.00
--	144334	Sealant, Tire (10 oz. tube)

NOTE: All component dimensions given in U.S. inches
1 inch = 25.4 mm

REPAIR PARTS

TRACTOR- -MODEL NO. 917. 277500

ENGINE

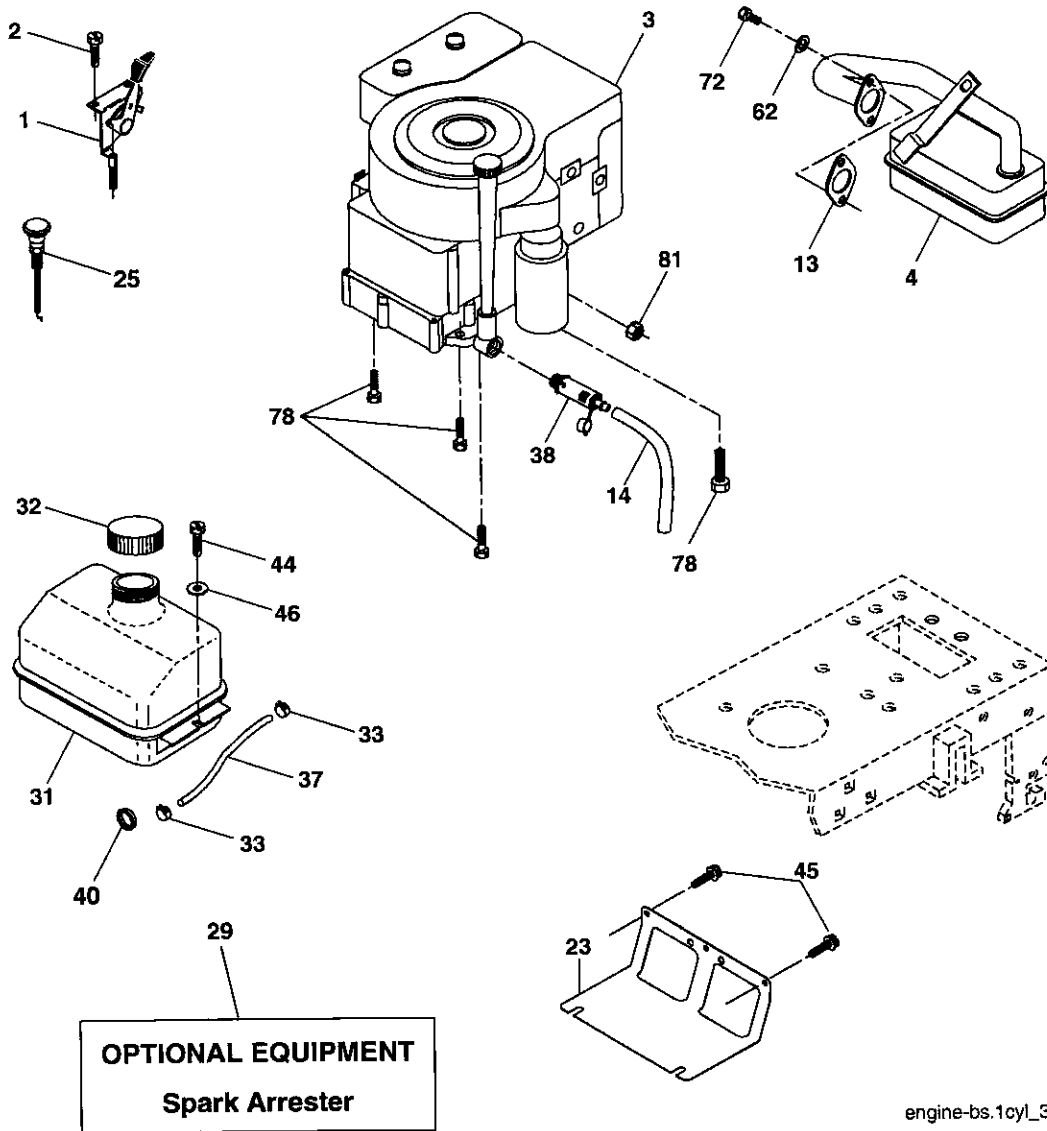

OPTIONAL EQUIPMENT
Spark Arrester

engine-bs.1cyl_38

KEY NO.	PART NO.	DESCRIPTION	KEY NO.	PART NO.	DESCRIPTION
1	170545	Control, Throttle/Choke	38	181654	Plug Drain Oil Easy
2	17720408	Screw, Hex Head, Thread Cutting 1/4-20 x 1/2	40	124028X	Bushing, Snap, Fuel Line
3	-----	Engine, Briggs Model 283H07-0400-E1 (See Breakdown)	44	17670412	Screw, Hex Washer Head, Thd., Roll. 1/4-20 x 3/4
4	137352	Muffer	45	17000612	Screw Hxwsh Thdr 3/8-16 x 3/4
13	165291	Gasket	46	19091416	Washer 9/32 x 7/8 x 16 Ga.
14	148456	Tube Drain Oil Easy	62	10010500	Washer Split
23	169837	Shield Brn/Dbr Guard	72	71070512	Screw Hex Head Cap 5/16-18 x 3/4
25	187770X428	Control Choke	78	17060620	Screw 3/8-16 x 1-1/4
29	137180	Arrestor, Spark	81	73510400	Nut Keps Hex 1/4-20
31	187750	Tank, Fuel			
32	140527	Cap Assembly, Fuel Sears, Vented			
33	123487X	Clamp, Hose			
37	137040	Line, Fuel			

NOTE: All component dimensions given in U.S. inches 1 inch = 25.4 mm

REPAIR PARTS

TRACTOR- -MODEL NO. 917. 277500

MOWER LIFT

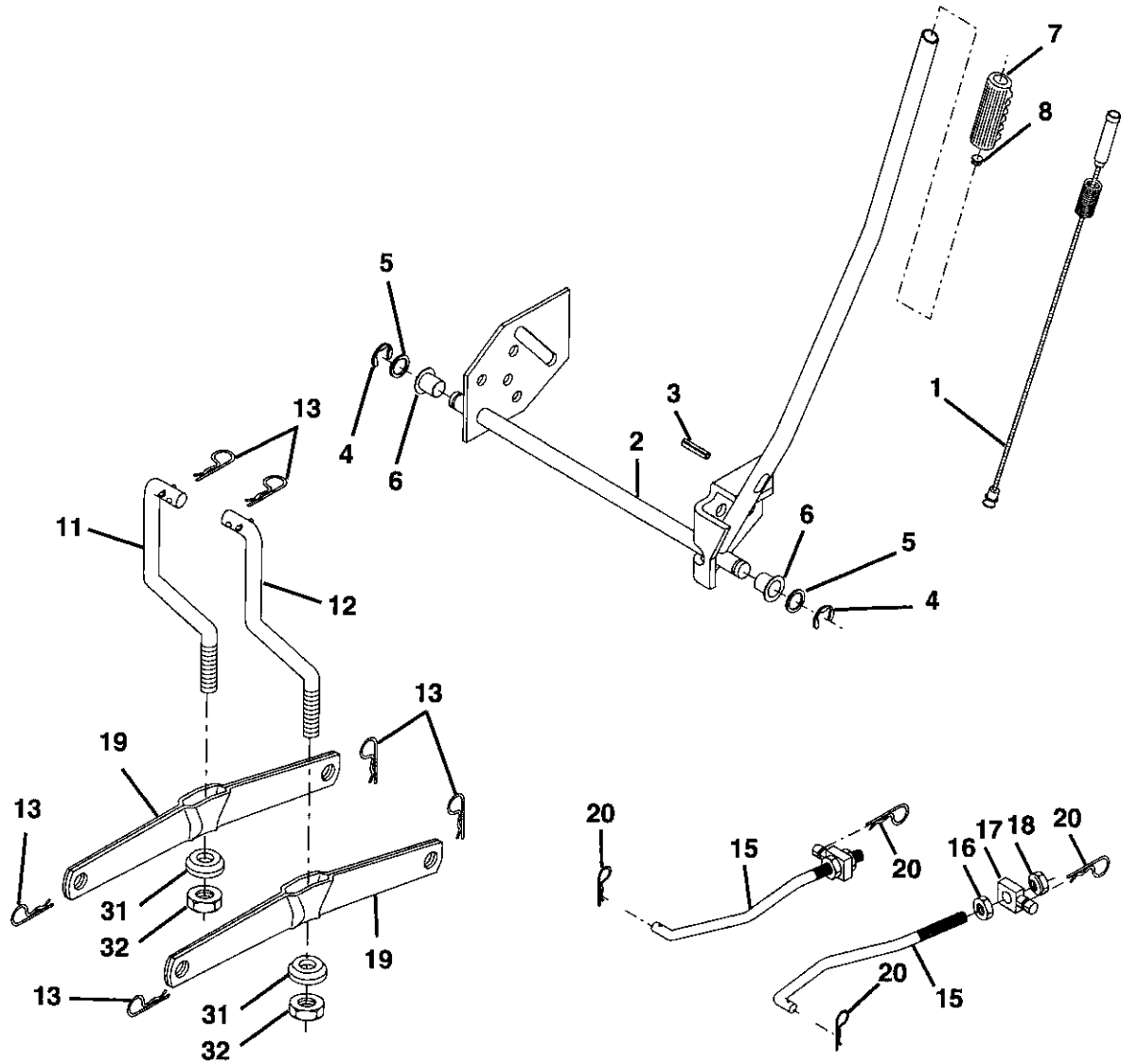

lift-rh.1piece_3

KEY NO.	PART NO.	DESCRIPTION
1	159460	Washer Asm Inner Spring W/ Plunger
2	159471	Shaft Asm. Lift
3	105767X	Pin Groove
4	12000002	E Ring #5133-62
5	19211621	Washer 21/32 x 1 x 21 Ga.
6	120183X	Bearing Nylon
7	125631X	Grip Handle Fluted
8	122365X	Button Plunger Read
11	139865	Link Asm Lift L.H.
12	139866	Link Asm Lift R.H.

KEY NO.	PART NO.	DESCRIPTION
13	STD624008	Retainer Spring
15	173288	Link Front
16	73350800	Nut Jam Hex 1/2-13 unc
17	175689	Trunnion Blk Zinc
18	73800800	Nut Lock w/Wsh 1/2-13 unc
19	139868	Arm Suspension Mower
20	163552	Retainer Spring
31	169865	Bearing, Pvt. Lift
32	73540600	Nut Crownlock 3/8-24

NOTE: All component dimensions given in U.S. inches
1 inch = 25.4 mm

REPAIR PARTS

TRACTOR- -MODEL NO. 917. 277500

MOWER

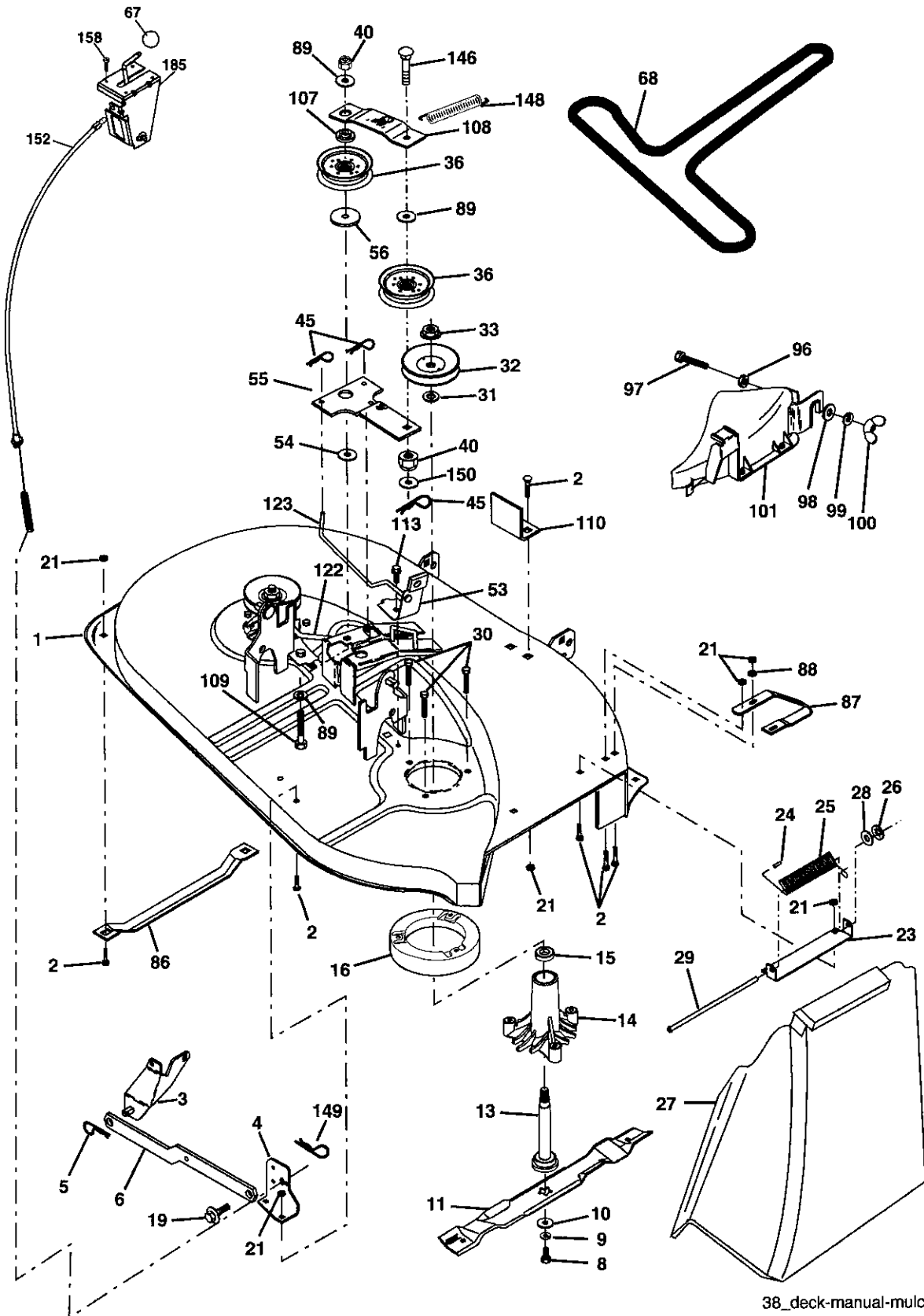

38_deck-manual-mulch_3

REPAIR PARTS

TRACTOR- -MODEL NO. 917. 277500

MOWER

KEY NO.	PART NO.	DESCRIPTION	KEY NO.	PART NO.	DESCRIPTION
1	170280	Mower Housing Assembly	68	180214	Belt
2	72140506	Bolt, Carriage 5/16-18 x 3/4	69	76020312	Pin, Cotter 3/32 x 3/4
3	138017	Bracket Asm. Fram Sway Bar	86	7631J	Runner, LH
4	169970	Bracket, Asm. Deck Sway Bar	87	128772	Runner, RH
5	4939M	Retainer, Spring	88	19111216	Washer 11/32 x 3/4 x 16 Ga
6	178024	Bar Sway Deck	89	19131311	Washer 13/32 x 13/16 x 11 Ga.
8	850857	Bolt, Hex 3/8-24 x 1-1/4 Gr 8	96	73930600	Nut Centerlock 3/8-16 unc
9	10030600	Washer, Lock, Hlcl Sprg 3/8	97	74930620	Bolt 3/8-16 x 1-1/4
10	140296	Washer, Hard Blade Mower Vented	98	19132016	Washer 13/32 x 1-1/4 x 16 Ga.
11	134148	Blade, Mower, Mulching 38"	99	10040600	Washer Lock 3/8
13	137645	Shaft and Bearing Assembly (In-cludes Key Number 15)	100	135651	Nut Wing
14	128774	Mandrel Housing, Vented	101	132803	Cover Asm. Mulching
15	110485X	Ball Bearing, Mandrel	107	133502	Spacer, Retainer
16	174493	Stripper, Mower, Vented	108	133503	Stiffener, Idler Arm
19	132827	Bolt, Shoulder	109	74760640	Bolt, Hex Head 3/8-16 x 2-1/2
21	73680500	Nut, Crownlock 5/16-18	110	142587	Upstop Deck Front 38"
23	137607	Bracket, Mower Deflector	113	17060512	Screw 5/16-18 x 3/4
24	105304X	Cap, Sleeve	122	131289	Rod, Brake, LH
25	123713X	Spring, Deflector	123	169971	Rod, Brake, RH
26	110452X	Nut, Push	146	165891	Bolt Carriage Idler
27	106736X428	Shield, Deflector	148	169022	Spring Return Idler
28	19111016	Washer 11/32 x 3/4 x 16 Ga	149	165898	Retainer Spring Yellow Zinc
29	106735X	Rod, Hinge	150	19091210	Washer 9/32 x 3/4 x 10 Ga.
30	173984	Screw, Thdro Washer Hd	152	172758	Cable Clutch 38 In
31	187690	Washer, Spacer	158	17720408	Screw Hex Thd Cut 1/4-20 x 1/2
32	153532	Pulley, Mandrel	185	188234	Head Asm. Cable Clutch
33	178342	Nut, Flangelock 9/16	--	130794	Mandrel Assembly (Includes Housing, Shaft and Shaft Hardware Only - Pulley Not Included)
36	131494	Pulley, Idler, Flat	--	181209	Mower Replacement, Complete (Std. Deck-Order Separately mulcher components key nos. 96-101)
40	73680600	Nut Crownlock 3/8-16 unc			
45	4497H	Retainer, Spring			
53	130840	Brake Assembly			
54	178515	Washer Hardened			
55	133840	Idler Arm Assembly			
56	165723	Spacer, Retainer			
67	149846	Knob			

NOTE: All component dimensions given in U.S. inches
1 inch = 25.4 mm

REPAIR PARTS

TRACTOR- -MODEL NO. 917. 277500

PEERLESS TRANSAXLE - MODEL NUMBER LTH2000

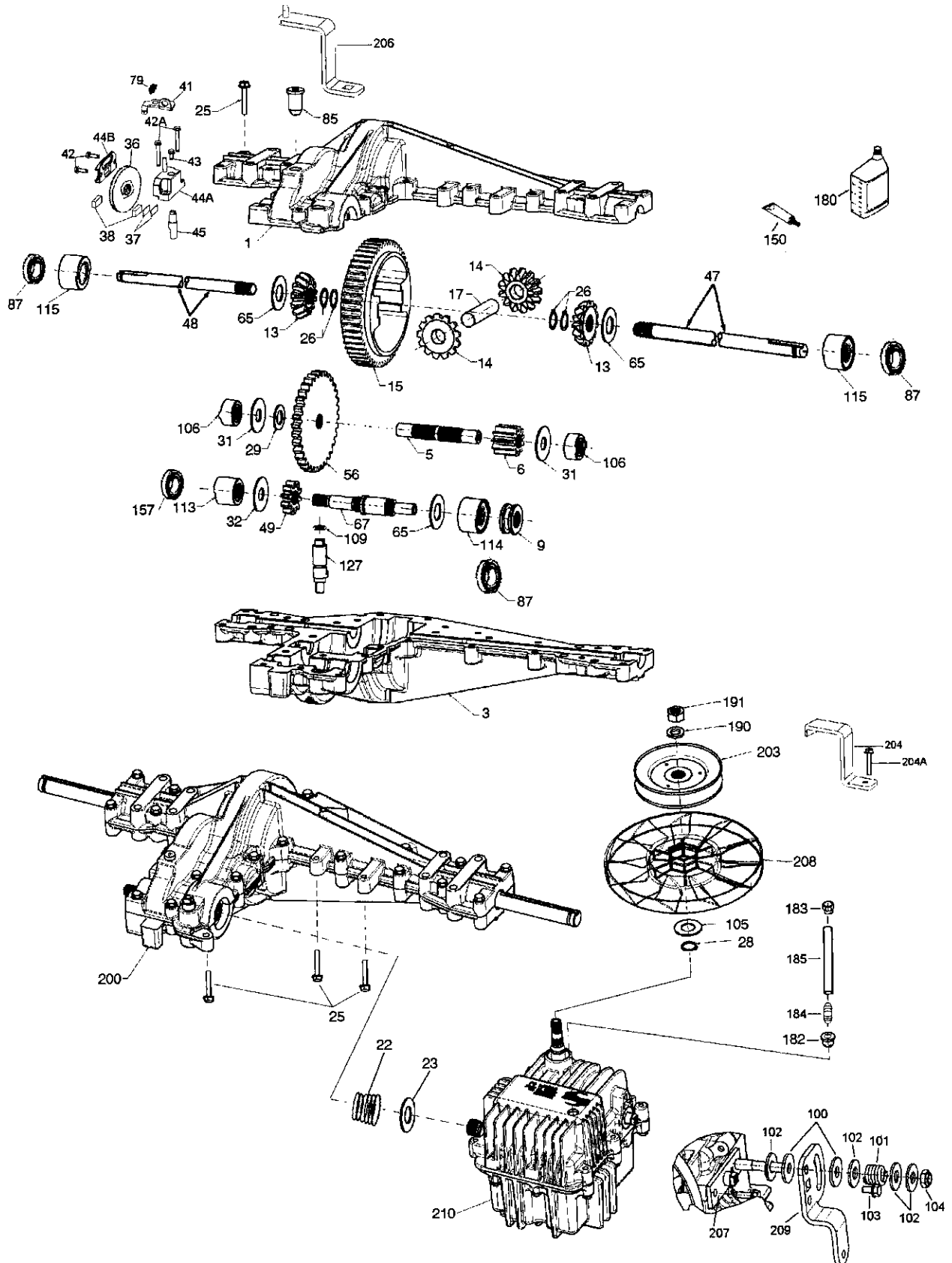

REPAIR PARTS

TRACTOR- -MODEL NO. 917. 277500

PEERLESS TRANSAXLE - MODEL NUMBER LTH2000

KEY NO.	PART NO.	DESCRIPTION	KEY NO.	PART NO.	DESCRIPTION
1	772151	Cover L.H.	70	786196	Spacer .625 .765
3	770135	Case	79	792201	Spring
5	776355	Counter Shaft	85	792154	Oil Fill Plug
6	778263	Spur Gear 11T	87	788088A	Oil Seal 3/4"
9	786197	Neutral Sleeve (.572)	99	792141	Washer .377ID .058W
13	778368	Bevel Gear (Incl. 14) (13 Teeth)	100	792200	Snubber Washer
14	778368	Bevel Gear (Incl. 13) (13 Teeth)	101	792199	Snubber Spring .47ID
15	778373	Ring Gear (54 Teeth)	102	792184	Washer .437ID .078W
17	786139	Drive Pin	103	792193	Screw, 1/4-28 x .490
22	792194	Spring	104	792198	Nut, 3/8-24
23	792195	Washer .750 ID	105	780096	Washer .625 ID .057W
25	792073A	Screw 1/4-20 x 1-1/4"	106	786162	Sleeve Assembly
26	792125	Retaining Ring	107	792046	Screw, 1/4-20 x 1"
28	792035	Retaining Ring	109	788104	"O" Ring
29	780065	Washer .627 ID .091W	113	786199	Sleeve Ass'y (Incl. 157)
31	780189	Washer .563 ID .062W	114	786200	Sleeve Ass'y (Incl. 87)
36	790071	Brake Disk	115	786198	Sleeve Assembly (Incl. 87)
37	790007	Brake Pad Plate	127	784384	Shift Lever Ass'y (Incl. 109)
38	799021	Brake Pad	150	788093A	Liquid Gasket RTV Silicon
40	792204	Roll Pin .25	157	788102	Oil Seal 9/16"ID
41	790102	Brake Lever	180	730229	BOil Spec. (80W90)
42	792202	Screw, 1/4-20 x 3/4	182	788103	Grommet
42A	792203	Screw, 1/4-20 x 1-3/4	183	792118	Relief Valve
43	792171	Screw, 10-24 x .500	184	792196	Hose Barb
44A	790100	Inside Brake (Mach)	185	798050	Tubing 1/2 x 5
44B	790099	Outside Brake (Casting)	190	792150	Washer
45	790101	Actuator Rod	191	792151	Nut 7/16-20
47	774869	Axle 16.812	200	794787	Differential (Gear Reduction Drive)
48	774688	Axle 11.625	203	798044	Pulley & Hub Ass'y
49	778378	Spur Gear 18T	206	798055	Disconnect Lever
56	778379	Spur Gear 81T	207	798053	Mounting Plate
65	780195	Washer .750ID .062W	208	798040	Fan
67	776440	Brakeshaft	209	798054	Control Lever
			210	794788	Hydro Module LH Fender Control

REPAIR PARTS

TRACTOR- -MODEL NO. 917. 277500

BRIGGS & STRATTON ENGINE - - MODEL NUMBER 283H07, TYPE NUMBER 0400-E1

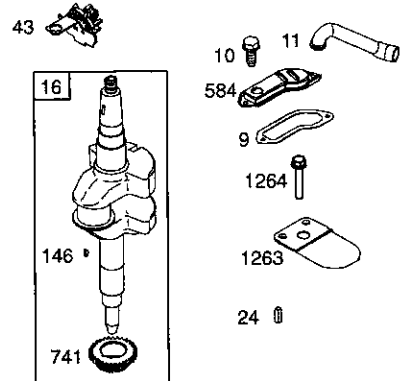
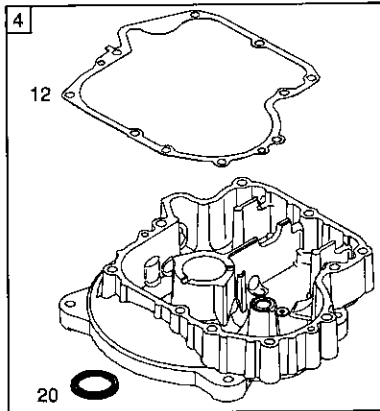
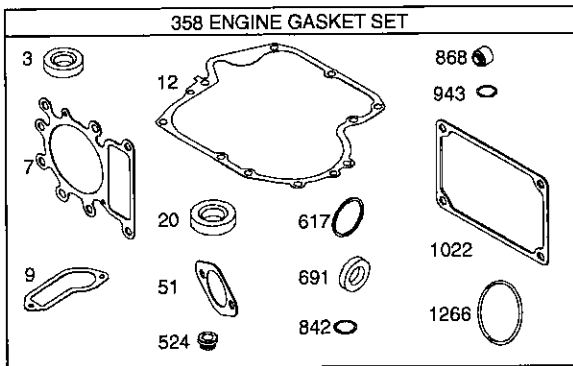
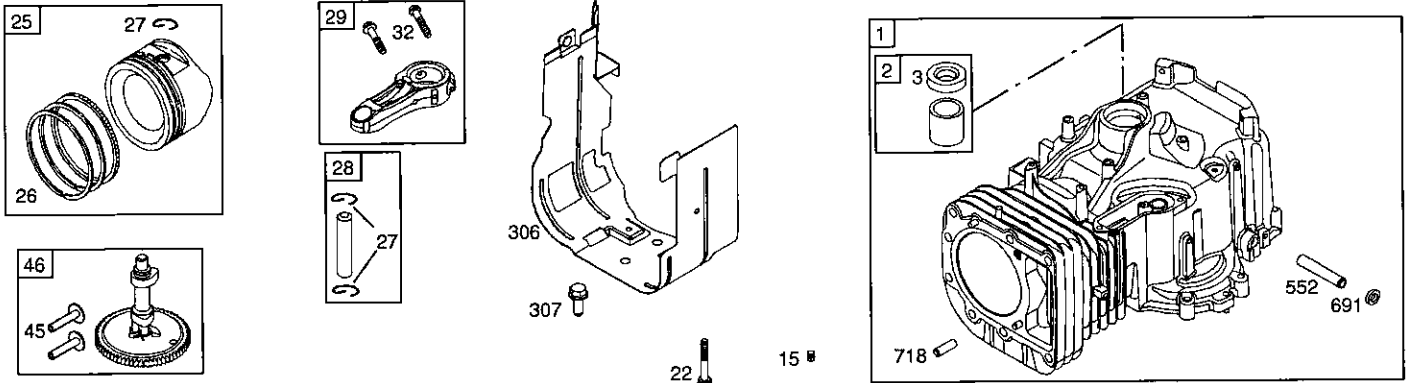

1019 LABEL KIT

1058 OWNER'S MANUAL

1036 EMISSION LABEL

1329 REPLACEMENT ENGINE

1330 OPERATOR MANUAL

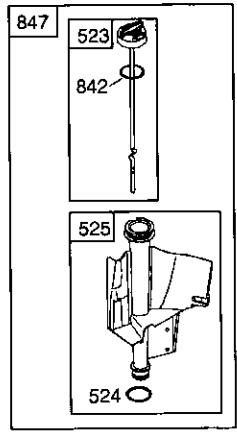
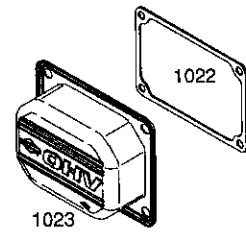
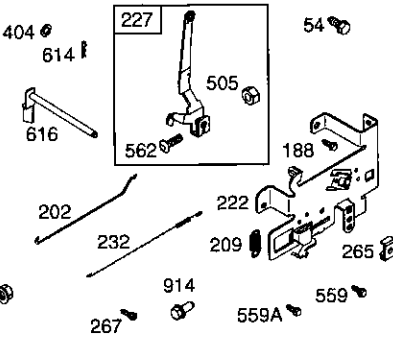
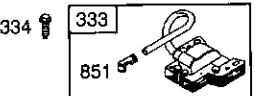
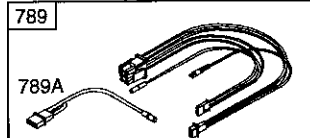
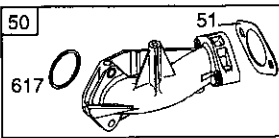
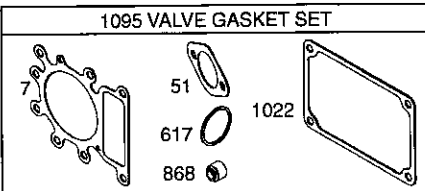
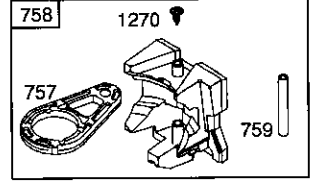

REPAIR PARTS

TRACTOR- -MODEL NO. 917. 277500

BRIGGS & STRATTON ENGINE - - MODEL NUMBER 283H07, TYPE NUMBER 0400-E1

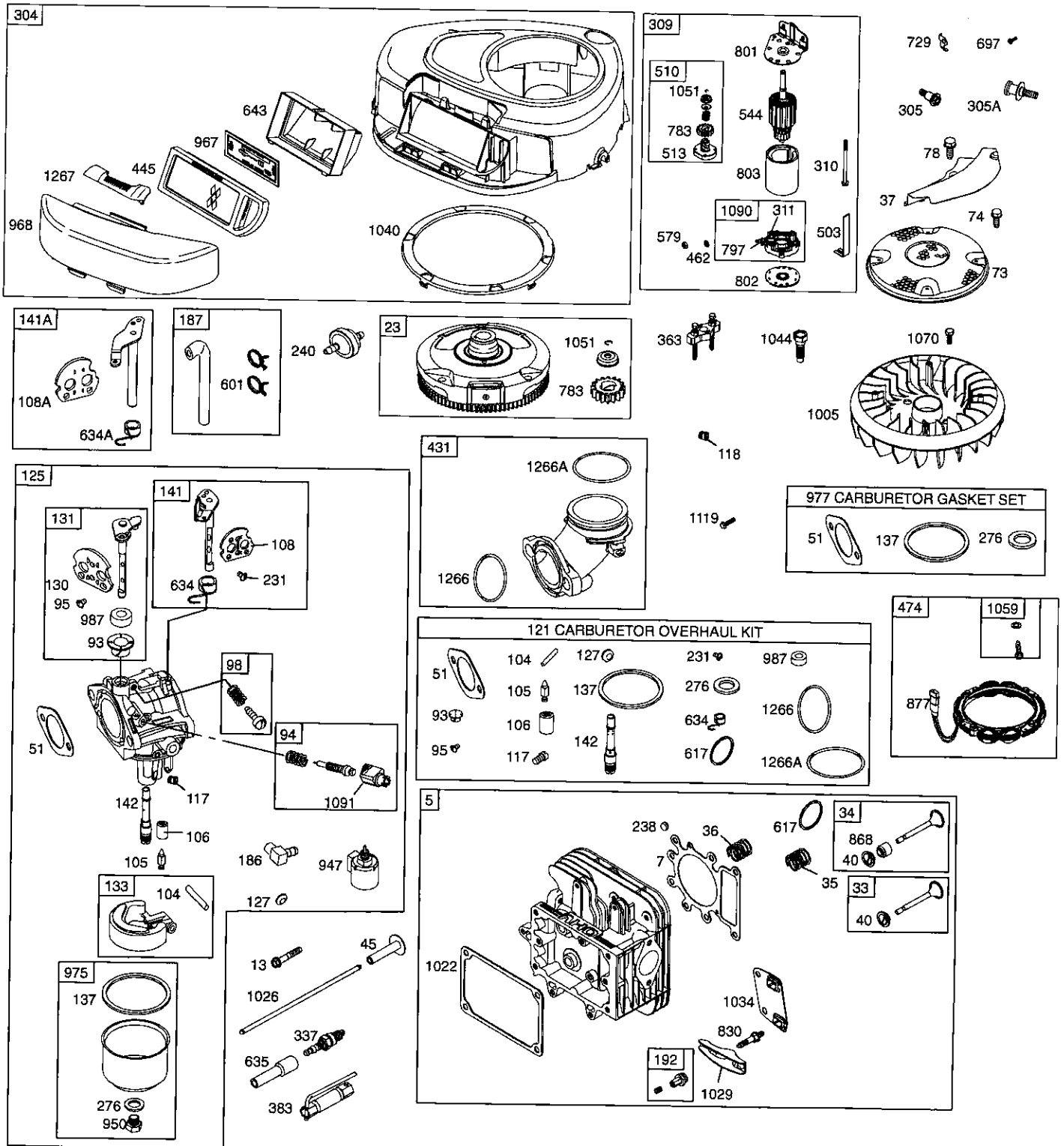

REPAIR PARTS

TRACTOR- -MODEL NO. 917. 277500

BRIGGS & STRATTON ENGINE - - MODEL NUMBER 283H07, TYPE NUMBER 0400-E1

KEY NO.	PART NO.	DESCRIPTION	KEY NO.	PART NO.	DESCRIPTION
1	697132	Cylinder Assembly	105	231855	∅ Valve-Float Needle
2	399265	Kit-Bushing/Seal (Magneto Side)	106	690577	∅ Seat-Inlet
3	391086	• Seal-Oil (Magneto Side)	108	690464	Valve-Choke (Manual Choke)
4	697106	Sump-Engine	108A	692344	Valve-Choke (Choke A Matic)
5	698147	Head-Cylinder	117	694352	∅ Jet-Main (Standard)
7	273280	•+ Gasket-Cylinder Head	118	697492	Jet-Main (High Altitude)
9	697109	• Gasket-Breather	121	697241	Kit-Carburetor Overhaul
10	697157	Screw (Breather Assembly)	125	698445	Carburetor
11	697113	Tube-Breather	127	695005	Plug-Welch
12	697110	• Gasket-Crankcase	130	691750	Valve-Throttle
13	690360	Screw (Cylinder Head)	131	494379	Kit-Throttle Shaft
15	690946	Plug-Oil Drain	133	494381	Float-Carburetor
16	697127	Crankshaft	137	281165	∅‡ Gasket-Float Bowl
20	690947	• Seal-Oil (PTO Side)	141	495097	Kit-Choke Shaft (Manual Choke)
22	692125	Screw (Crankcase Cover/Sump)	141A	495931	Kit-Choke Shaft (Choke A Matic)
23	693557	Flywheel	142	697140	∅ Nozzle-Carburetor
24	222698	Key-Flywheel	146	691639	Key-Timing
25	698371	Piston Assembly (Standard)	186	698174	Connector-Hose
--	698394	Piston Assembly (.020" Oversize)	187	699331	Line-Fuel (Molded) (Cut to Required Length)
26	698375	Ring Set (Standard)	188	691693	Screw (Control Bracket)
--	698397	Ring Set (.020" Oversize)	192	691986	Adjuster-Rocker Arm
27	698469	Lock-Piston Pin	202	691841	Link-Mechanical Governor
28	697099	Pin-Piston	209	692208	Spring-Governor
29	697126	Rod-Connecting (Standard)	222	694042	Bracket-Control
32	692852	Screw (Connecting Rod)	227	691374	Lever-Governor Control
33	695760	Valve-Exhaust	231	691636	Screw (Choke Valve)
34	695761	Valve-Intake	232	691842	Spring-Governor
35	691279	Spring-Valve (Intake)	238	691843	Cap-Valve
36	691279	Spring-Valve (Exhaust)	240	394358	Filter-Fuel
37	697352	Guard-Flywheel	265	691024	Clamp-Casing
42	499586	Keeper-Valve	267	695134	Screw (Casing Clamp)
43	691968	Slinger-Governor/Oil	276	692255	∅‡ Washer-Sealing
45	690564	Tappet-Valve	304	698402	Housing-Blower
46	790400	Camshaft	305	697102	Screw (Blower Housing)
48	697761	Short Block	305A	697103	Screw (Blower Housing)
50	690193	Manifold-Intake	306	697107	Shield-Cylinder
51	692137	•∅‡+ Gasket-Intake	307	691003	Screw (Cylinder Shield)
53	690227	Stud (Carburetor)	309	693551	Motor-Starter
54	691148	Screw (Intake Manifold)	309A	-----	Motor-Starter (For Replacement Starter Motor, See Reference 309)
73	697133	Screen-Rotating	310	690323	Bolt (Starter Motor)
74	697987	Screw (Rotating Screen)	311	497608	Brush Set
78	691003	Screw (Flywheel Guard)	311A	395538	Brush Set
93	690602	∅ Bushing-Throttle Shaft			
94	498030	Kit-Idle Mixture			
95	691636	Screw (Throttle Valve)			
98	495800	Kit-Idle Speed			
104	690525	∅ Pin-Float Hinge			

NOTE: All component dimensions given in U.S. inches 1 inch = 25.4 mm

REPAIR PARTS

TRACTOR- -MODEL NO. 917. 277500

BRIGGS & STRATTON ENGINE - - MODEL NUMBER 283H07, TYPE NUMBER 0400-E1

KEY NO.	PART NO.	DESCRIPTION	KEY NO.	PART NO.	DESCRIPTION
333	492341	Armature-Magneto	830	691095	Stud (Rocker Arm)
334	691061	Screw (Magneto Armature)	842	691031	• Seal-O Ring (Dipstick Tube)
337	691043	Plug-Spark	847	697611	Dipstick/Tube Assembly
358	697151	Gasket Set-Engine	851	692424	Terminal-Spark Plug
363	19203	Flywheel Puller	868	690968	•+ Seal-Valve
383	89838	Wrench-Spark Plug	877	393456	Wire-Connector/Alternator
404	691691	Washer (Governor Crank)	914	690960	Screw (Rocker Cover)
431	697122	Elbow-Intake	947	694393	Solenoid-Fuel
445	698083	Filter-Air Cleaner Cartridge	950	691657	Screw (Float Bowl)
462	691261	Washer (Starter Cable)	967	697015	Filter-Pre Cleaner
474	696459	Alternator	968	698403	Cover-Air Cleaner
503	691532	Strap-Starter	975	495933	Bowl-Float
505	691251	Nut (Governor Control Lever)	977	690192	Gasket Set-Carburetor
510	693699	Drive-Starter	987	691326	∅ Seal-Throttle Shaft
510A	497606	Drive-Starter	1005	699043	Fan-Flywheel
513	692024	Clutch-Drive	1019	699196	Kit-Label
523	699908	Dipstick	1022	272475	•+ Gasket-Rocker Cover
524	691032	• Seal-Dipstick Tube	1023	692492	Cover-Rocker Arm
525	697184	Tube-Dipstick	1026	692003	Rod-Push (Intake)
544	692034	Starter-Armature	---	692011	Rod-Push (Exhaust)
552	697144	Bushing-Governor Crank	1029	691751	Arm-Rocker
559	697561	Screw (Remote Choke Stop)	1034	690822	Guide-Push Rod
559A	693675	Screw (Remote Choke Stop)	1036	790464	Label-Emission
562	691119	Bolt (Governor Control Lever)	1040	698368	Plate-Trim
579	691029	Nut (Starter Cable)	1044	698139	Screw (Flywheel)
584	697112	Cover-Breather Passage	1051	691265	Ring-Retaining
601	95162	Clamp-Hose	1058	275038	Owner's Manual
614	691620	Pin-Cotter	1059	698516	Kit-Screw/Washer
616	692012	Crank-Governor	1070	690372	Screw (Flywheel Fan)
617	692138	∅ • Seal-O Ring (Intake Manifold)	1090	691293	Retainer-Brush
634	690801	∅ Spring/Seal Assembly (Manual Choke)	1091	691333	Cap-Limiter
634A	690802	∅ Spring/Seal Assembly (Choke A Matic)	1095	690190	Gasket Set-Valve
635	691909	Boot-Spark Plug	1119	691183	Screw (Alternator)
643	698401	Retainer-Air Filter	1263	697124	Reed-Breather
654	690958	Nut (Carburetor)	1264	697104	Screw (Breather Reed)
691	692407	• Seal-Governor Shaft	1266	691917	•∅ Seal-O Ring (Intake Elbow)
697	690372	Screw (Drive Cap)	1266A	697123	∅ Seal-O Ring (Intake Elbow)
718	690959	Pin-Locating	1267	697419	Latch-Blower Housing
729	691224	Clip-Wire	1270	697156	Plug-AVS Counterweight
741	697128	Gear-Timing	1329	31C707-0230	Replacement Engine (Transfer the speed limiter control assembly and governor spring to the replacement engine)
757	697607	Link-Counterweight	1330	275038	Owner's Manual
758	697134	Counterweight			
759	697392	Pin-Counterweight			
783	693713	Gear-Pinion			
789	698329	Harness-Wiring			
789A	790544	Harness-Wiring			
797	693167	Nut (Brush Retainer)	•		Included in Engine Gasket Set, Key. No. 358
801	691283	Cap-Drive	∅		Included in Carburetor Overhaul Kit, Key. No. 121
802	691286	Cap-End	‡		Included in Carburetor Gasket Set, Key. No. 977
803	693757	Housing-Starter	+		Included in Valve Gasket Set, Key. No. 1095

NOTE: All component dimensions given in U.S. inches 1 inch = 25.4 mm

LIMITED WARRANTY ON CRAFTSMAN RIDING EQUIPMENT

For two (2) years from the date of purchase, if this Craftsman Riding Equipment is maintained, lubricated and tuned up according to the instructions in the owner's manual, Sears will repair or replace free of charge any parts that are found to be defective in material or workmanship according to the guidelines of coverage listed below. Sears will also provide free labor for these applicable warranted parts for 2 full years. During the first 30 days of purchase, there will be no charges to service the product at your home for issues covered by this warranty. (See exclusions below). For your convenience, IN HOME warranty service will still be available after the first 30 days of purchase, but a trip charge will apply. This charge will be waived if the Craftsman product is dropped off at an authorized Sears location. For the nearest authorized Sears location, please call 1-800-4-MY-HOME®. This warranty applies only while this product is within the United States.

This Warranty does not cover:

- Expendable items which become worn during normal use, including but not limited to blades, spark plugs, air cleaners, belts, and oil filters.
- Standard Maintenance Servicing, oil changes, or tune-ups
- Tire replacement or repair caused by punctures from outside objects, such as nails, thorns, stumps, or glass.
- Repairs necessary because of operator abuse, including but not limited to, damage caused by towing objects beyond the capability of the riding equipment, impacting objects that bend the frame or crankshaft, or over-speeding the engine.
- Repairs necessary because of operator negligence, including but not limited to, electrical and mechanical damage caused by improper storage, failure to use the proper grade and amount of engine oil, failure to keep the deck clear of flammable debris, or failure to maintain the equipment according to the instructions contained in the owner's manual.
- Engine (fuel system) cleaning or repairs caused by fuel determined to be contaminated or oxidized (stale). In general, fuel should be used within 30 days of its purchase date.
- Normal deterioration and wear of the exterior finishes, or product label replacement.
- Riding equipment used for commercial or rental purposes.

LIMITED WARRANTY ON BATTERY

For ninety (90) days from date of purchase, if any battery included with this riding equipment proves defective in material or workmanship and our testing determines the battery will not hold a charge, Sears will replace the battery at no charge. During the first 30 days of purchase, there will be no charges to replace the battery at your HOME. After the first 30 days, for your convenience, IN-HOME warranty service will still be available but a trip charge will apply. This charge will be waived if the Craftsman product is dropped off at an authorized Sears location. For the nearest authorized Sears location, please call 1-800-4-MY-HOME®.

This battery warranty applies only while this product is within the United States.

This warranty gives you specific legal rights, and you may also have other rights, which vary, from state to state.

Sears, Roebuck and Co., Dept. 817WA, Hoffman Estates, IL 60179

