

**REPAIR PARTS MANUAL**  
**MODEL NO. 990380**  
**Lawn Tractor**

---



# HOW TO USE THIS MANUAL

This manual is designed to provide the customer with a means to identify the parts on his/her tractor when ordering repair parts. The illustrations may or may not represent the actual assemblies; therefore, it is not recommended to use this manual as a guide to assemble or disassemble the tractor. Some hardware and parts are drawn larger in order to more readily identify them.

Each tractor has its own model number.

The model number for your tractor can be found on the fender under the seat.

When ordering parts, always give the following information:

- Product - "Tractor"
- Model Number - "990380"
- Part Number
- Part Description

## TABLE OF CONTENTS

<b>SCHEMATIC .....</b>	<b>3</b>
<b>ELECTRICAL.....</b>	<b>4-5</b>
<b>CHASSIS .....</b>	<b>6-7</b>
<b>DRIVE.....</b>	<b>8-9</b>
<b>ENGINE.....</b>	<b>10-11</b>
<b>STEERING.....</b>	<b>12-13</b>
<b>MOWER DECK .....</b>	<b>14-15</b>
<b>MOWER LIFT.....</b>	<b>16</b>
<b>SEAT .....</b>	<b>17</b>
<b>DECALS.....</b>	<b>18</b>
<b>TRANSAXLE BREAKDOWN .....</b>	<b>20-21</b>
<b>ENGINE BREAKDOWN.....</b>	<b>22-25</b>
<b>WARRANTY.....</b>	<b>BACK COVER</b>

# TRACTOR- -MODEL NO. 917.990380

## SCHEMATIC

SCH11

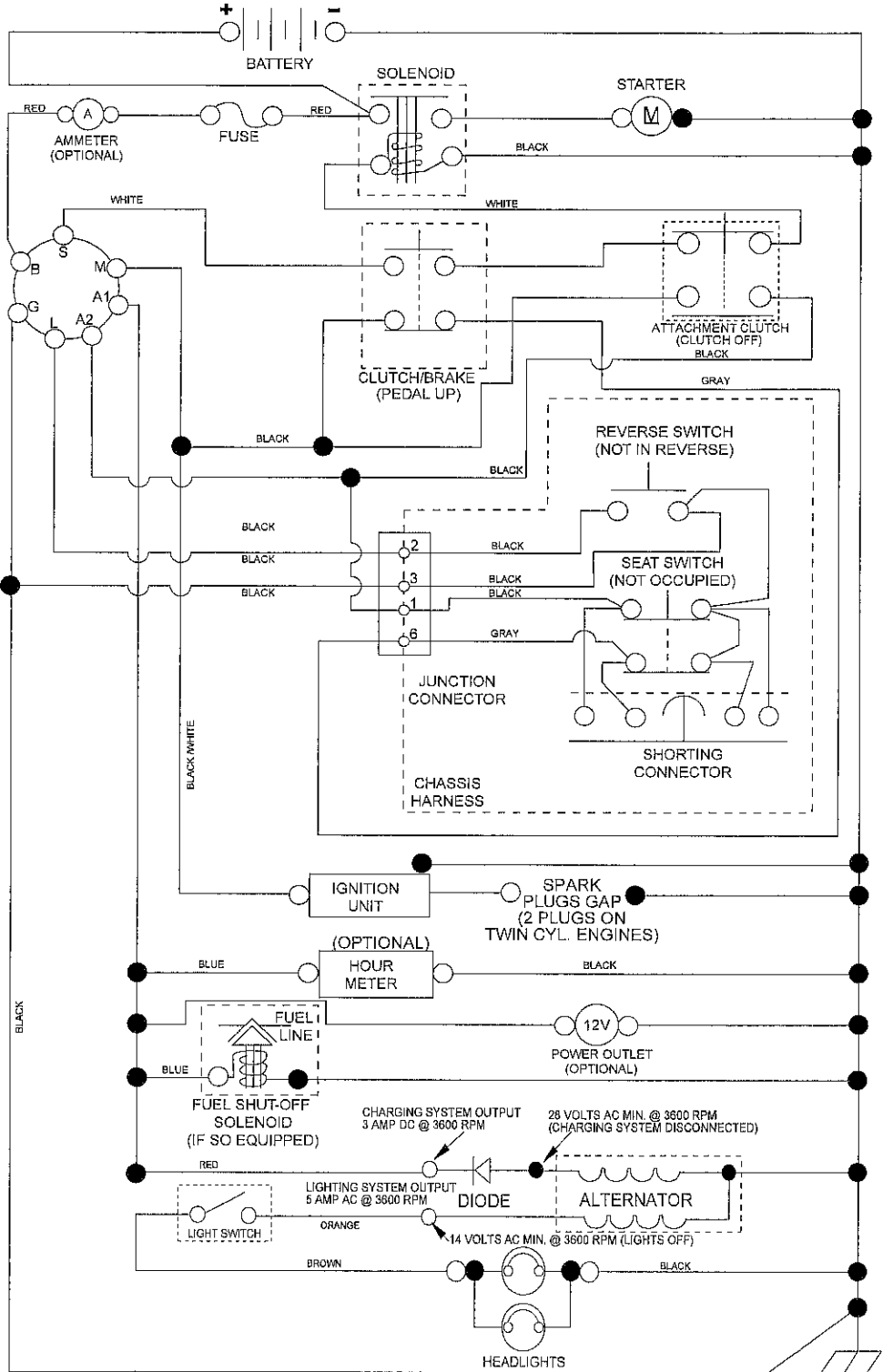

**NOTE**  
YOUR TRACTOR IS EQUIPPED WITH A SPECIAL ALTERNATOR SYSTEM. THE LIGHTS ARE NOT CONNECTED TO THE BATTERY, BUT HAVE THEIR OWN ELECTRICAL SOURCE. BECAUSE OF THIS, THE BRIGHTNESS OF THE LIGHTS WILL CHANGE WITH ENGINE SPEED. AT IDLE THE LIGHTS WILL DIM. AS THE ENGINE IS SPEEDED UP, THE LIGHTS WILL BECOME THEIR BRIGHTEST.

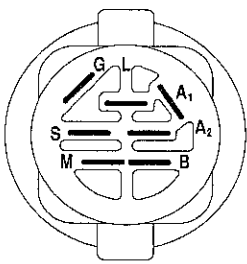

IGNITION SWITCH

POSITION	CIRCUIT "MAKE"
OFF	M+G+A1
RUN/OVERRIDE	B+A1
RUN	B+A1 L+A2
START	B + S + A1

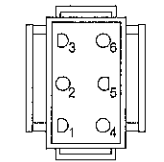

CHASSIS HARNESS CONNECTOR (MATING SIDE)

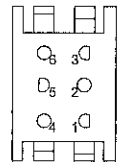

DASH HARNESS CONNECTOR (MATING SIDE)

WIRING INSULATED CLIPS  
NOTE: IF WIRING INSULATED CLIPS WERE REMOVED FOR SERVICING OF UNIT, THEY SHOULD BE RE-INSTALLED TO PROPERLY SECURE YOUR WIRING.

NON-REMOVABLE CONNECTIONS

REMOVABLE CONNECTIONS



# TRACTOR- -MODEL NO. 917.990380

## ELECTRICAL

KEY NO.	PART NO.	DESCRIPTION
1	163465	Battery
2	74760412	Bolt Hex Hd 1/4-20 unc x 3/4
8	193228	Box Battery
16	176138	Switch Interlock Push-In
21	400252	Harness Socket Light w/4152J
22	4152J	Bulb Light
25	581498001	Cable Starter
26	175158	Fuse
27	73510400	Nut Keps Hex 1/4-20 unc
28	421686	Cable, Ground
29	401545	Switch, Seat
30	193350	Switch, Ign
33	411934	Key/Chain
34	110712X	Switch Light / Reset
40	581023101	Harness Ign. Dash (if equipped with rear solenoid)
--	401098	Harness Ign. Dash (if equipped with front solenoid)
43	192507	Solenoid
55	17060512	Screw Thdrol 5/16-18 x 3/4 TYTT
71	581023001	Harness Ign. Chassis (if equipped with rear solenoid)
--	400449	Harness Ign. Chassis (if equipped with front solenoid)
79	175242	Bulbholder Asm. Incandescent
87	197802	Switch Interlock Clutch Cable
90	435395	Cover Terminal Battery
92	196615	Harness Pigtail Reverse Switch
93	192540	Screw Plastite 10 - 14 x 2 00
94	191834	Module Reverse Ros
99	17670412	Screw
106	174814	Pal Nut

**NOTE:** All component dimensions given in U.S. inches.  
1 inch = 25.4 mm.

# TRACTOR- -MODEL NO. 917.990380

## CHASSIS AND ENCLOSURES

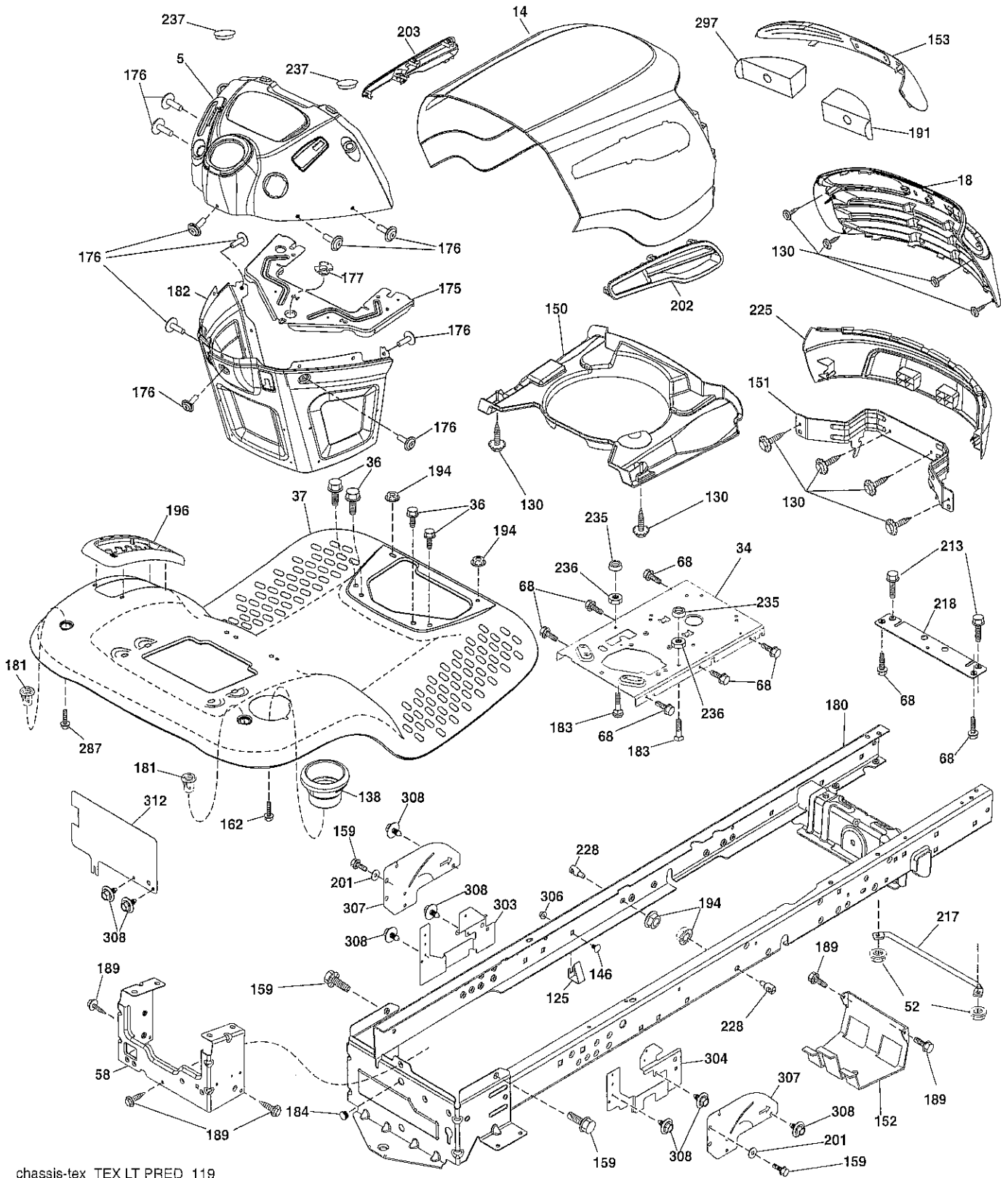

chassis-tex\_TEX LT PRED\_119

# TRACTOR- -MODEL NO. 917.990380

## CHASSIS AND ENCLOSURES

KEY NO.	PART NO.	DESCRIPTION
5	408874X428	Dash
14	198416X615	Hood
18	423156	Grille
34	580910801	Plate Engine
36	17060512	Screw 5/16-18 x 3/4
37	414872X615	Fender
52	73680500	Nut Crown Lock 5/16-18
58	412280	Drawbar Upper
68	17490508	Screw Thdrol 5/16-18 x 1/2
125	581684801	Clip Fuel Line
130	416358	Screw #10 x 0.750
138	193224X428	Cupholder
146	581857901	Bolt
150	400267	Duct Heat Hood
151	187568	Bracket Pivot
152	199535	Shield Browning/Debris
153	400550X599	Lens
159	17000612	Screw Hexwsh Thdrol 3/8-16 x 3/4
162	142432	Screw Hex Wsh Hi-Lo 1/4 x 1/2
175	199472	Crossmember
176	400776	Screw 10-24 x 5/8 Wshd Qdrx
177	195228	Bushing Steering
180	415063	Chassis
181	193102X428	Bushing Mtg. Fender Crgo.
182	407176	Dash Lower
183	74520520	Bolt Full Thd 5/16-18 x 1-1/4
184	587554101	Plug
189	17000512	Screw 5/16-18 x 3/4
191	416502	Insert Reflective RH
194	73900500	Nut Lock Hex Flange 5/16-18
196	414579	Console Asm. Deck Lift
201	19132016	Washer
202	580427401	Vent Hood Side Panel RH
203	580427501	Vent Hood Side Panel LH
213	74760512	Bolt Hex Hd 5/16-18 x 3/4
217	409167	Rod Pivot Hood
218	196395	X-Piece Hood Stop
225	400549X615	Bumper
228	195161	Stud Fastener
235	406129	Spacer Fender
236	73930500	Nut Center Lock 5/16-18
237	403704	Plug Mount Cargo
287	17600406	Screw 1/4-20 x 3/8
297	401827	Insert Reflective LH
303	587493401	Shield, Lower LH
304	587865102	Shield RH
306	73900600	Nut Lock
307	587494601	Shield, Upper
308	171877	Bolt, 5/16-18 unc x 3/4
312	587493002	Shield, Drawbar

**NOTE:** All component dimensions given in U.S. inches.  
1 inch = 25.4 mm.

# TRACTOR- -MODEL NO. 917.990380

## DRIVE

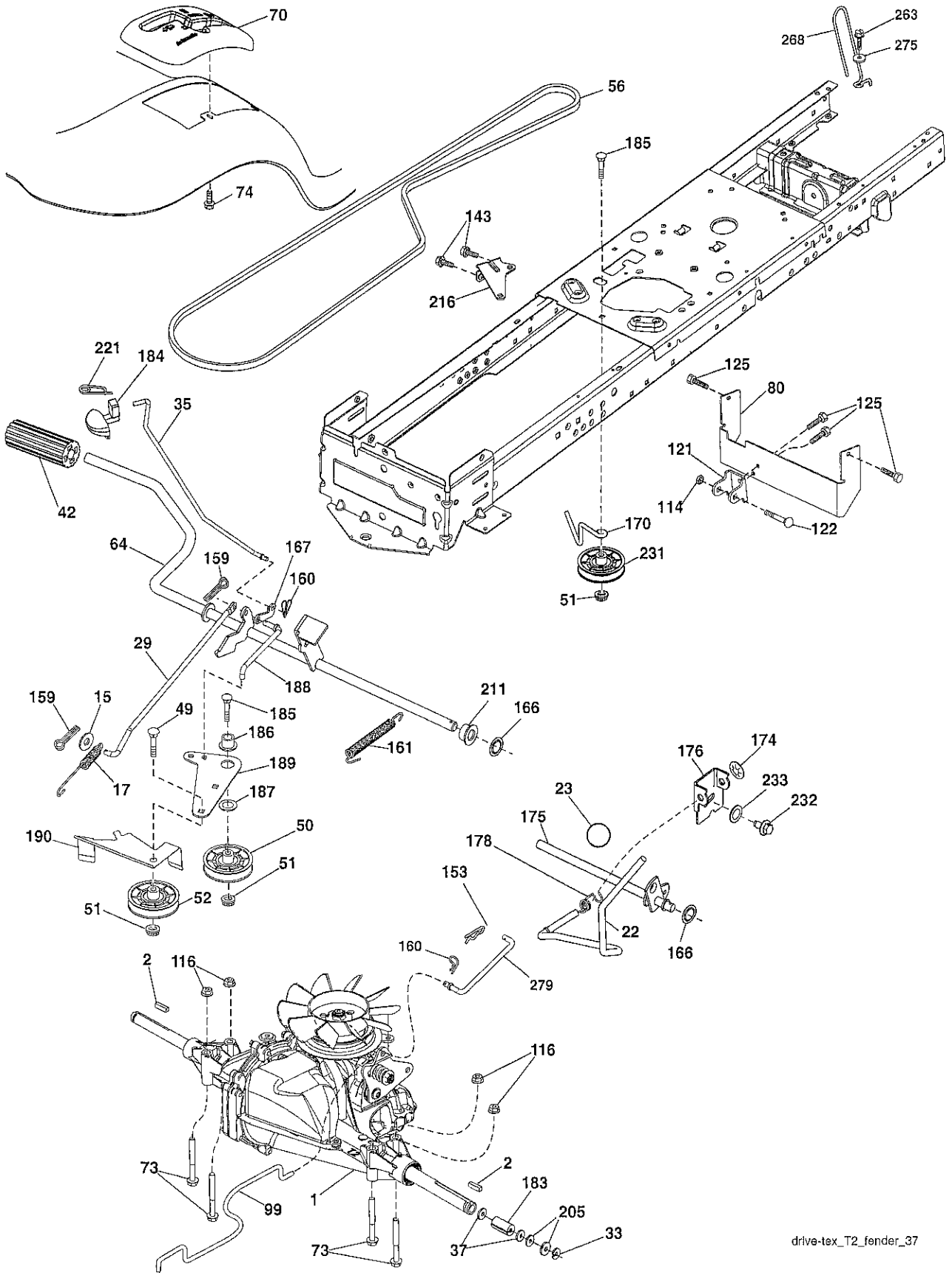

drive-tex\_T2\_fender\_37



# TRACTOR- -MODEL NO. 917.990380

## DRIVE

KEY NO.	PART NO.	DESCRIPTION	KEY NO.	PART NO.	DESCRIPTION
1	-- -- -- --	Transaxle, T2-CDBE-5X1A-18C1 (581115602) (Order parts from transaxle manufacturer.)	160	169484	Retainer Clip
2	123583X	Key Square	161	105709X	Spring, Return, Clutch
15	19131316	Washer 13/32 x 13/16 x 16 Ga.	166	429164	Nut Push .625
17	197296	Spring, Brake	167	405257	Latch Brake Parking
22	197660	Rod Shift	170	413430	Keeper Belt Centerspan
23	106933X	Knob	174	197289	Nut Push
29	581506401	Rod, Brake	175	408539	Shaft Asm Shift
33	12000001	Ring E	176	196214	Arm Clevis Rod Shift
35	401031	Rod, Brake, Park	178	197456	Spring Shift
37	121749X	Washer 25/32 x 1-1/4 x 16	183	156972	Spacer Axle
42	8883R	Cover, Foot Pedal	184	199996X428	Handle Parking Brake
49	72110614	Bolt	185	72110622	Bolt
50	194327	Pulley Idler Flat	186	194321	Spacer Retainer
51	73900600	Lock Nut 3/8-16	187	19133210	Washer
52	194326	Idler V-Groove	188	194323	Link Clutch Ground Drive
56	581270501	V-Belt, Drive	189	194317	Bellcrank Ground Drive
64	196200	Shaft Asm. Pedal Brake Control	190	194318	Keeper Bellcrank Ground Drive
70	193220x428	Console	205	121748X	Washer 25/32 x 1-5/8 x 16 Ga.
73	74490544	Bolt Hex 5/16-18 x 2-1/2 G5	211	196212	Bushing Shaft
74	142432	Screw 1/4 x 1/2	216	196131	Bracket Pulley Idler
80	581550701	Strap Torque	221	403187	Retainer Spring Clip Handle
99	408418	Rod Spring Bypass	231	407287	Idler V-Groove
114	73800500	Nut Lock	232	74780716	Bolt 7/16-14 x 1 Gr 5
116	73900500	Nut Lock Hex Flange 5/16-18	233	405296	Washer Serrated
121	175611	Bracket Strap Torque	263	17000612	Screw 3/8-16 x 3/4
122	72010520	Bolt 5/16-18 x 2.50	268	182402	Guard Muffler
125	17000512	Screw 5/16-18 x 3/4	275	19131614	Washer 13/32 x 1 x 14 Ga.
143	17490508	Screw THDROL 5/16-18	279	424155	Link Shift
153	4497H	Retainer Spring 1"			
159	76020412	Pin Cotter 1/8 x 3/4			

**NOTE:** All component dimensions given in U.S. inches  
1 inch = 25.4 mm

# TRACTOR- -MODEL NO. 917.990380

## ENGINE

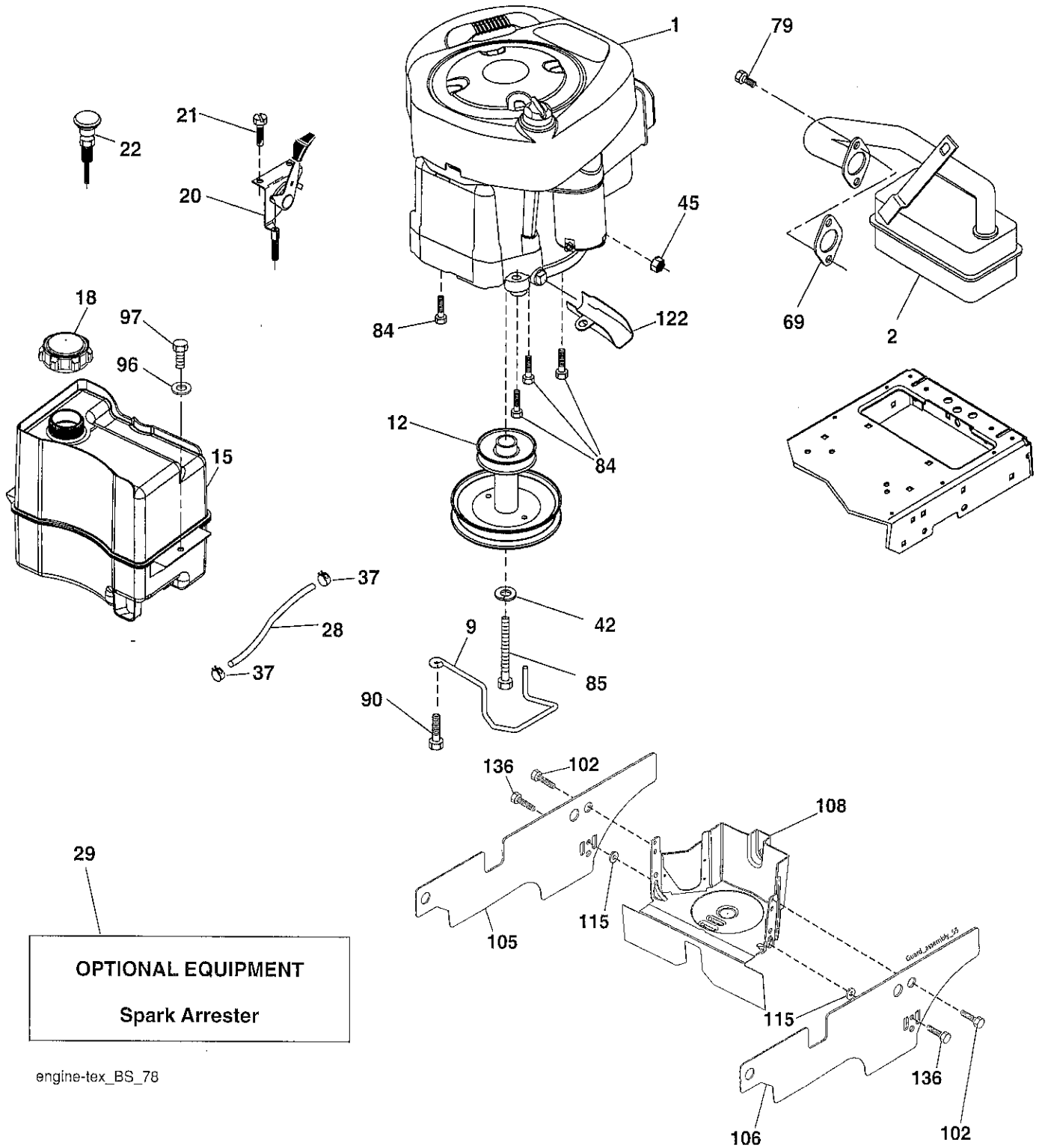

# TRACTOR- -MODEL NO. 917.990380

## ENGINE

KEY NO.	PART NO.	DESCRIPTION
1	-- --	Engine B&S Model No. 31R777-0003-B1 (585688801) (See Transaxle Break-down.)
2	137352	Muffler
9	584908001	Keeper Belt Engine
12	586478501	Pulley Engine
15	581289901	Tank Fuel 1.50
18	430220	Cap Asm
20	176636X428	Control Throttle
21	416358	Screw #10 x 0.750
22	187771X428	Control Choke
28	137040	Fuel Line
29	137180	Spark Arrester Kit
37	123487X	Clamp Hose
42	10040700	Washer Lock 7/16
45	73510400	Nut Keps Hex 1/4-20 unc
69	165291	Gasket
79	192334	Screw Socket Hd 5/16-18 x .75
84	17060620	Screw 3/8-16 x 1-1/4
85	173937	Bolt Hex 7/16-20 x 4 x Gr. 5-1.5
90	17000616	Screw 3/8-16 x 1.0
96	19091416	Washer 9/32 x 7/8 x 16 Ga.
97	17670412	Screw 1/4-20 x 3/4
102	17000512	Screw 5/16-18 x 3/4
105	410528	Shield, Side LH
106	410529	Shield, Side RH
108	421794	Cover, Asm. Eng. Pulley
115	423062	Palnut 1/4
122	421922	Extension Drain Oil
136	137729	Screw

**NOTE:** All component dimensions given in U.S. inches  
1 inch = 25.4 mm

### Engine Power Rating Information

The gross power rating for individual gas engine models is labeled in accordance with SAE (Society of Automotive Engineers) code J1940 (Small Engine Power & Torque Rating Procedure), and rating performance has been obtained and corrected in accordance with SAE J1995 (Revision 2002-05). Torque values are derived at 3060 RPM; horsepower values are derived at 3600 RPM. Actual gross engine power will be lower and is affected by, among other things, ambient operating conditions and engine-to-engine variability. Given both the wide array of products on which engines are placed and the variety of environmental issues applicable to operating the equipment, the gas engine will not develop the rated gross power when used in a given piece of power equipment (actual "on-site" or net power). This difference is due to a variety of factors including, but not limited to, accessories (air cleaner, exhaust, charging, cooling, carburetor, fuel pump, etc.), application limitations, ambient operating conditions (temperature, humidity, altitude), and engine-to-engine variability. Due to manufacturing and capacity limitations, Briggs & Stratton may substitute an engine of higher rated power for this Series engine.

# TRACTOR- -MODEL NO. 917.990380

## STEERING ASSEMBLY

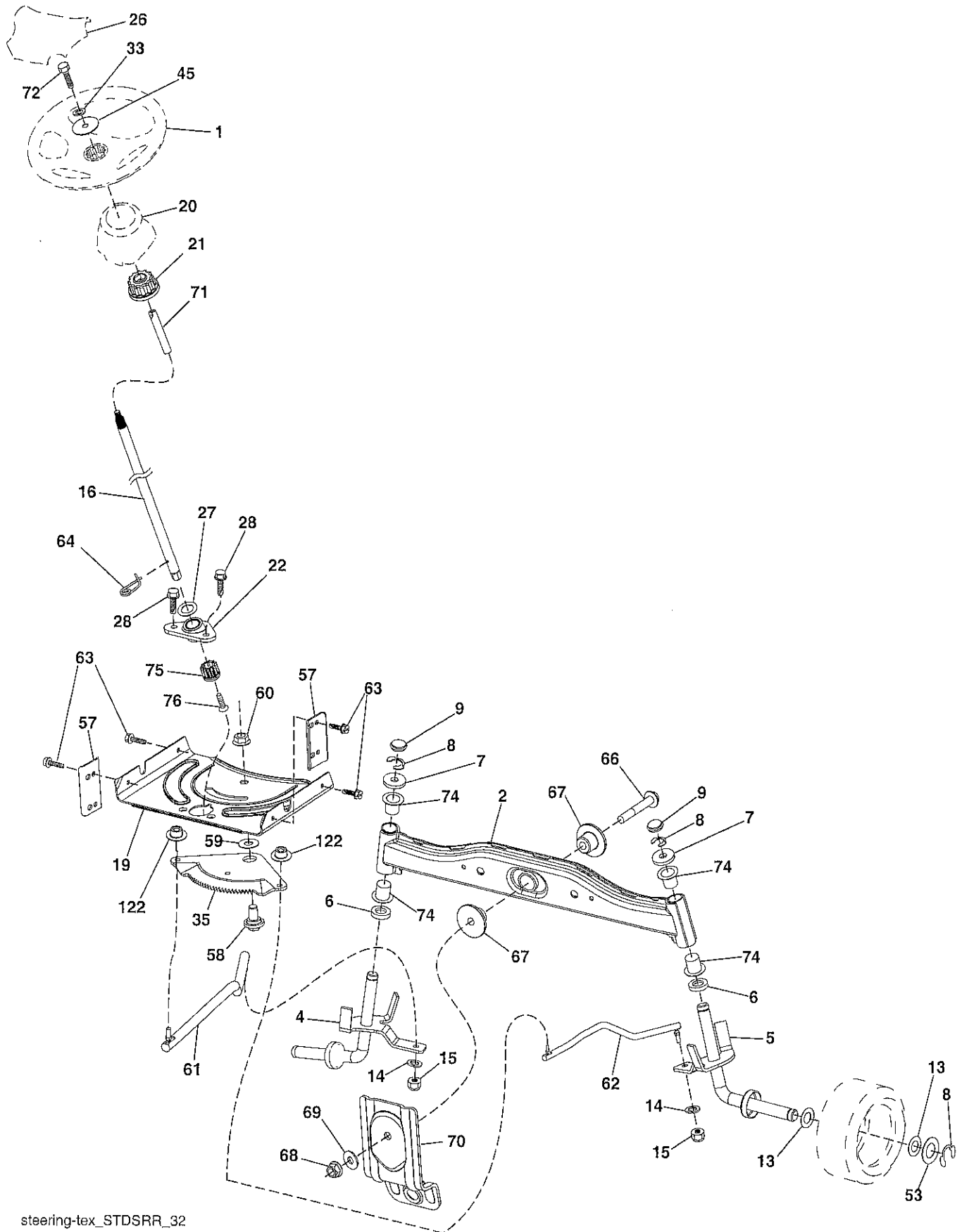

steering-tex\_STDSRR\_32

# TRACTOR- -MODEL NO. 917.990380

## STEERING ASSEMBLY

KEY NO.	PART NO.	DESCRIPTION
1	414803X428	Wheel, Steering
2	418168	Axle Asm., Front
4	403087	Spindle Asm., LH
5	403088	Spindle Asm., RH
6	6266H	Washer Thrust 0.75 x 1.23
7	121748X	Washer 25/32 x 1-5/8 x 16 Ga.
8	12000029	Ring, Clip #T5304-75
9	121232X	Cap, Spindle
13	121749X	Washer 25/32 x 1-1/4 x 16 Ga.
14	10040600	Washer Lock 3/8
15	73540600	Nut, Crown Lock 3/8-24 unf
16	585869202	Shaft Steering
19	194729	Plate Steering
20	400803X428	Boot, Steering
21	186737	Adapter, Wheel Steering
22	585029802	Bearing, Shaft
26	414852X428	Insert, Wheel Steering
27	19211616	Washer 21/32 x 1 x 16 Ga.
28	17000612	Screw 3/8-16 x 3/4
33	10040500	Washer Lock 5/16
35	194732	Gear, Sector Plate
45	19113812	Washer 11/32 x 2-3/8 x 12 Ga.
53	188967	Washer Hardened .793 x 1.637 x .060
57	407465	Bracket Upstop
58	194747	Bolt Shoulder Sector Pivot CFM
59	194748	Washer Thrust Sector Steering
60	73971000	Nut Flange Lock 5/8-11
61	194740	Draglink, LH
62	194741	Draglink, RH
63	17000512	Screw 5/16-18 x 3/4
64	199849	Retainer Clip Spring Steering
66	71020748	Bolt Hex Fghd 7/16-14 x 3 Serr
67	194737	Bushing PM Front Axle
68	73900700	Nut Lock
69	199162	Washer 1.5 x .505 x .118
70	585338801	Bracket Deck Susp. Front
71	190752	Shaft Ext. Steering
72	428982	Bolt Fin Hex 5/16-18 x 4
74	3366R	Bearing
75	580683702	Pinion
76	580683601	Screw, Head, Sock
122	444962	Cap Gear Sector

**NOTE:** All component dimensions given in U.S. inches.  
1 inch = 25.4 mm.

# TRACTOR- -MODEL NO. 917.990380

## MOWER

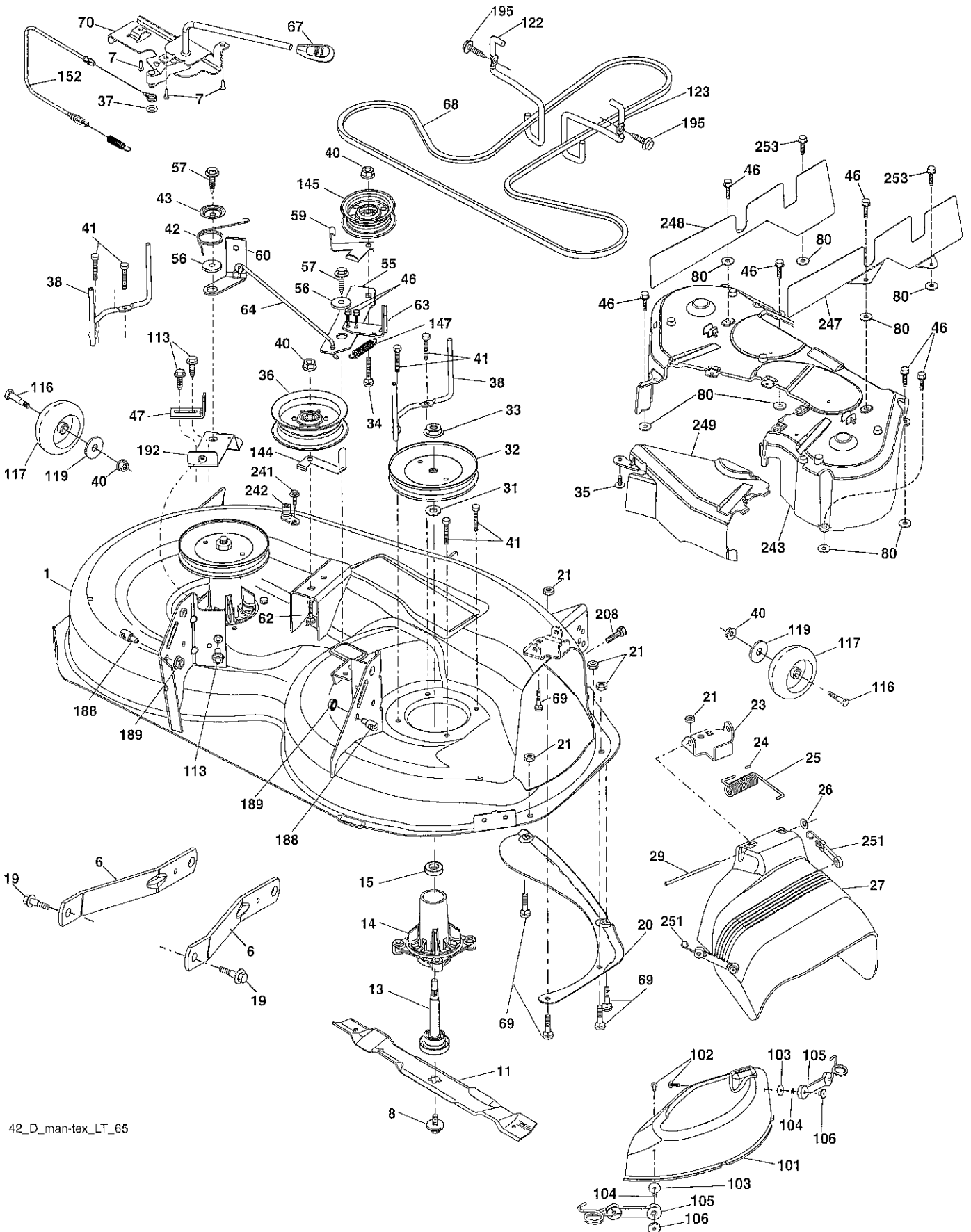

42\_D\_man-tex\_LT\_65

# TRACTOR- -MODEL NO. 917.990380

## MOWER

KEY NO.	PART NO.	DESCRIPTION	KEY NO.	PART NO.	DESCRIPTION
1	196495	Deck Weldment Mower	80	423062	Palnut 1/4
6	195186	Arm Suspension	101	193107	Cover, Asm. Mulching 42"
7	416358	Screw #10 x .750 BOS Thread	102	71081010	Screw Pan Hd Phillips 10-24 x 5/8
8	193003	Bolt/Washer asm 7/16-20 unf	103	19061216	Washer #10
11	424752	Blade, 42" 3NI	104	10071000	Washer Lock #10
13	192872	Shaft Assembly, Mandrel	105	160793	Latch Asm
14	187281	Housing, Mandrel	106	2029J	Nut Weld 327/304#10-24
15	110485X	Bearing, Ball, Mandrel	113	17000510	Bolt 5/16-18
19	196539	Bolt, Shoulder	116	4898H	Bolt, Shoulder
20	159770	Baffle Vortex	117	188606	Wheel, Gauge
21	73680500	Nut, Crownlock 5/16-18 unc	119	19121414	Washer 3/8 x 7/8 x 14 Ga.
23	192557	Bracket, Deflector	122	197258	Keeper Belt Engine LH
24	105304X	Cap, Sleeve	123	197259	Keeper Belt Engine RH
25	197026	Spring, Torsion, Deflector	144	199204	Keeper Belt
26	110452X	Nut, Push	145	193197	Pulley Idler, Flat
27	406520X428	Shield, Deflector	147	401971	Spring Return
29	131491	Rod, Hinge	152	584243501	Manual Clutch Cable
31	187690	Washer, Spacer	188	195161	Stud Fastener
32	197473	Pulley, Mandrel	189	73900500	Nut Lock Hex Flange
33	400234	Nut, Toplock, Flanged	192	197260	Bracket Brake Stand LH
34	72110612	Bolt Carr Sh. 3/8-16 x 1-1/2 Gr. 5	195	17000612	Screw Hex Wsh Thdr 3/8-16 x 3/4
35	133835	Fastner, Christmas Tree	208	17670608	Screw 3/8-16 x 1/2
36	197379	Pulley, Idler	241	152927	Screw TT #10-32.5. 3/8 Flange
37	19131316	Washer	242	415598	Port Washout
38	432520	Keeper Belt LH Mandrel	243	432394	Cover Asy. Tex Deck 42"
40	73900600	Nut, Lock Flg. 3/8-16 unc	247	430261	Shield, Deck Rh 42"
41	584953901	Bolt, Hex 3/8-18 x 1.19	248	430260	Shield, Deck Lh 42"
42	198410	Spring Torsion Brake	249	406514	Cover, Cable Clutch 38/42"
43	197256	Spring Torsion Retainer	253	427350	Rivet, Rulfok 25 x 24
46	137729	Screw Thd Roll 1/4-20 x 5/8	--	192870	Mandrel Assembly (Includes housing (key #14), shaft assembly (key #13), and bearing only (key #15) - pulley/nut/washer and blade bolt/washers not included)
47	197250	Bracket Clutch Cable	--	588119101	Replacement Mower, Complete
55	437110	Arm, Idler			
56	199092	Spacer, Retainer			
57	17000616	Screw 3/8-16 x 1			
59	141043	Guard, Tuv Idler			
60	197261	Arm Brake Mower			
62	72110616	Bolt Rd Hd Sq Nk 3/8-16 unc x 2			
63	199477	Arm Brake Mower			
64	199790	Link Brake Asm			
67	198398X428	Handle Clutch Cable			
68	429636	Drive, Belt			
69	72140505	Bolt			
70	401246	Clutch Asm Manual			

**NOTE:** All component dimensions given in U.S. inches  
1 inch = 25.4 mm

# TRACTOR- -MODEL NO. 917.990380

## MOWER LIFT

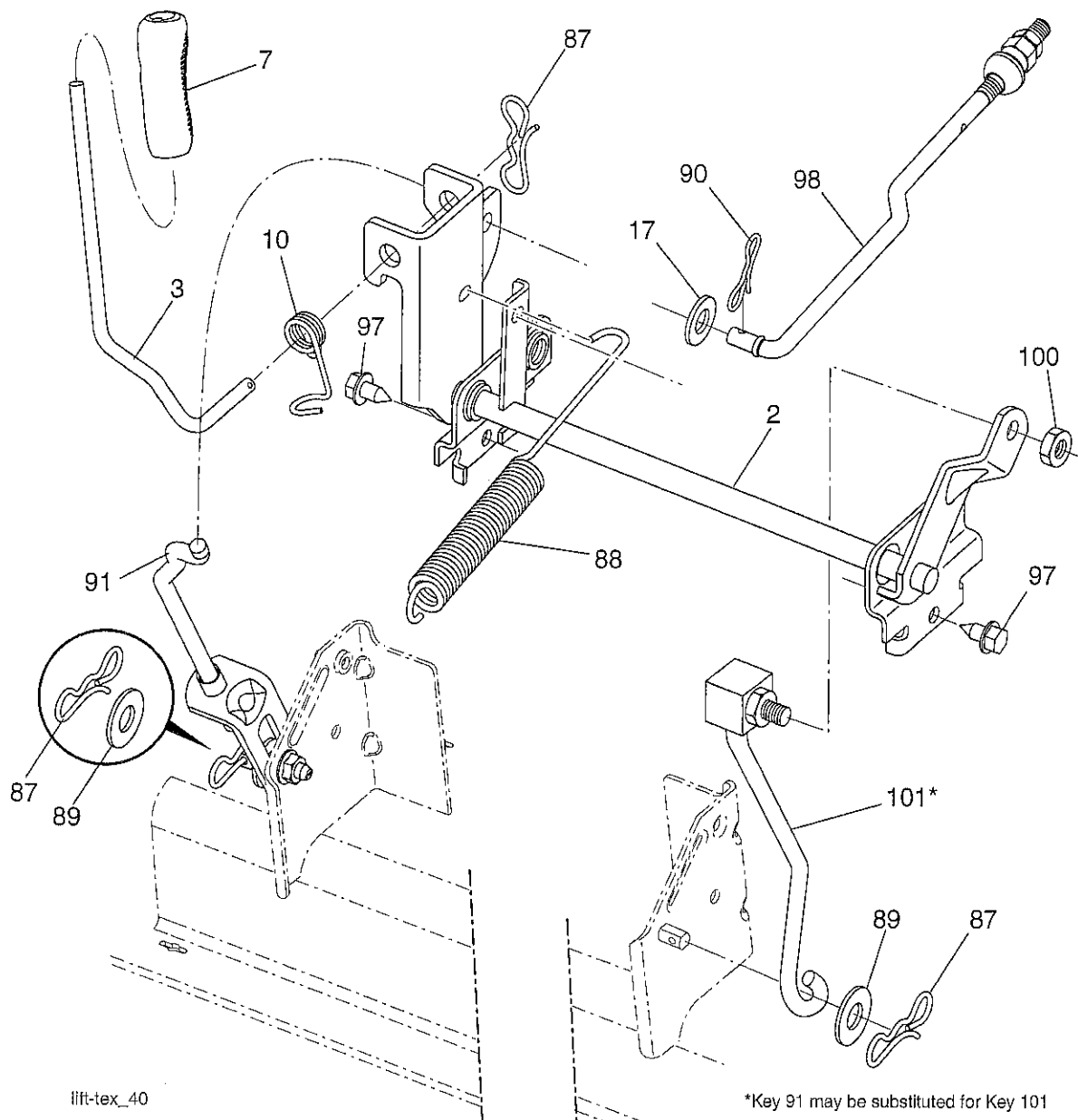

KEY NO.	PART NO.	DESCRIPTION
2	197250	Shaft Asm., Lift
3	195231	Lever Asm., Lift RH
7	445060X428	Grip, Lever
10	196314	Spring Torsion
17	19131312	Washer 13/32 x 13/16 x 12 Ga.
87	194209	Pin Cotter 7/16 Bow Tie Lock
88	410710	Spring Lift Assist
89	19191912	Washer Clear Zinc
90	194208	Pin Cotter 5/16 Bow Tie Lock

KEY NO.	PART NO.	DESCRIPTION
91	195181	Link Lift Susp Mower Rear
97	17000612	Screw 3/8-16 x .75
98	195270	Link Lift Susp. Front Mower
100	73930600	Nut Centerlock 3/8-16 unc
101	407003	Link Asm. Lift FXD

**NOTE:** All component dimensions given in U.S. inches  
1 inch = 25.4 mm



# TRACTOR- -MODEL NO. 917.990380

## SEAT ASSEMBLY

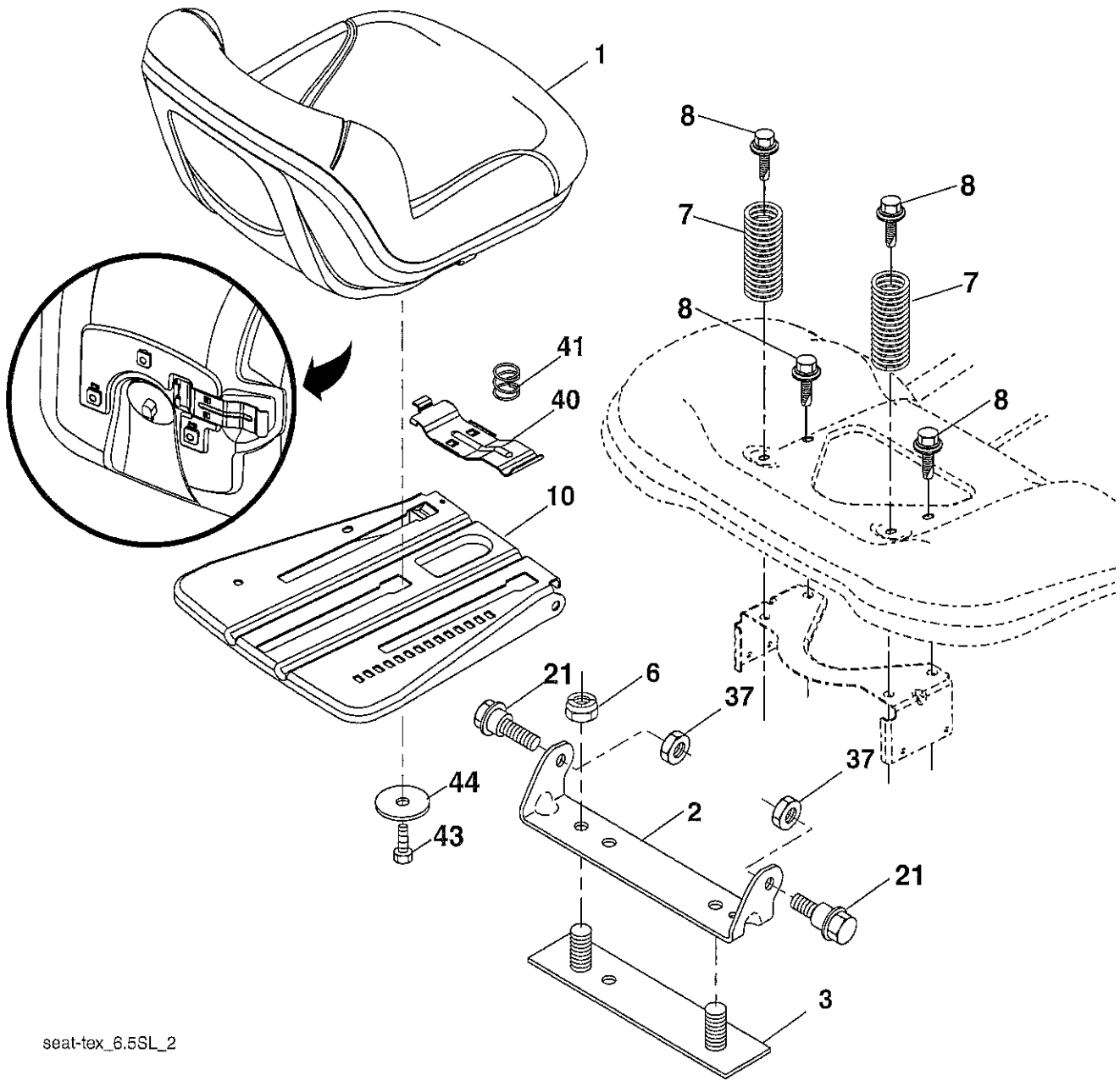

seat-tex\_6.5SL\_2

KEY NO.	PART NO.	DESCRIPTION
1	197250	Seat
2	180166	Bracket Pivot Fender
3	140675	Strap, Asm Fender
6	73800600	Nut, Lock w/Ins. 3/8-16 unc
7	124181X	Spring, Seat Cprsn
8	171877	Bolt 5/16-18 unc x 3/4 w/Sems
10	196977	Pan, Seat
21	171852	Bolt, Shoulder 5/16-18

KEY NO.	PART NO.	DESCRIPTION
37	73800500	Nut, Lock 5/16-18 unc
40	197661	Handle Slide
41	198200	Spring Latch
43	74760612	Bolt 3/8-16 unc x 3/4
44	19133812	Washer 13/32 x 2 3/8 x 12 Ga.

**NOTE:** All component dimensions given in U.S. inches.  
1 inch = 25.4 mm

# TRACTOR- -MODEL NO. 917.990380

## DECALS

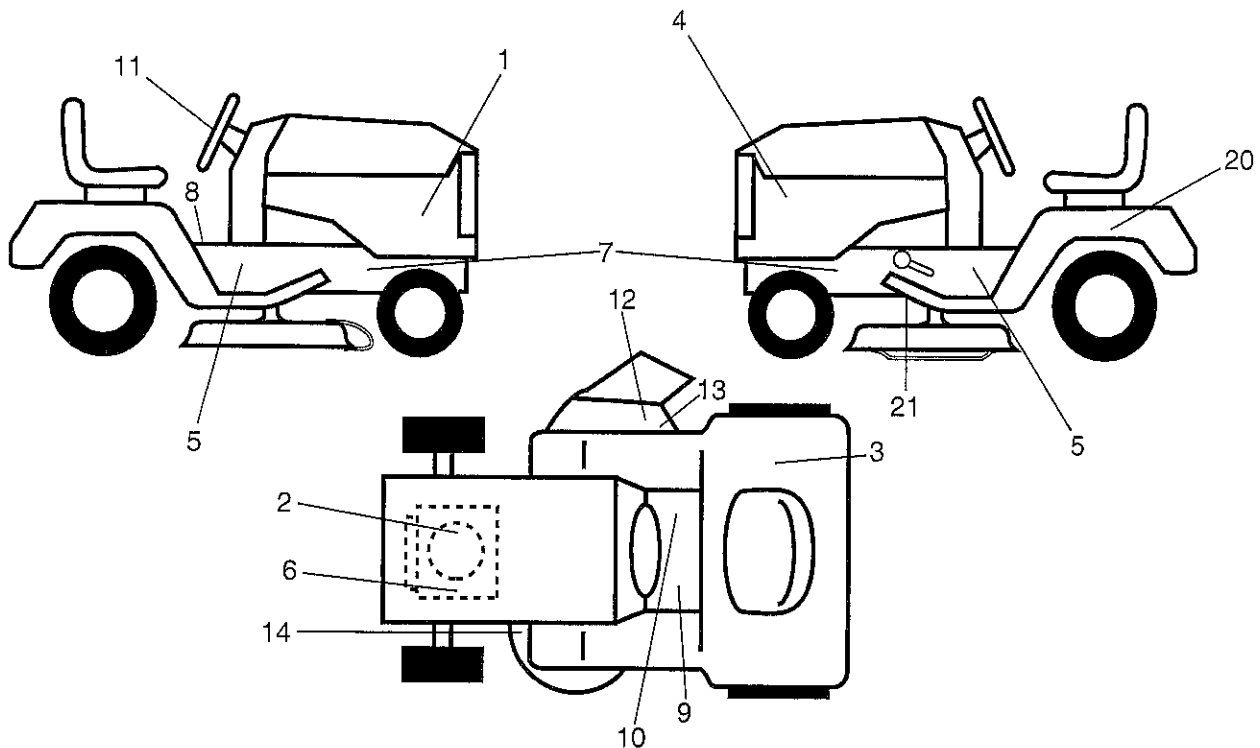

KEY NO.	PART NO.	DESCRIPTION
1	586207301	Decal Sideskirt RH
2	586373401	Decal Eng. H.P.
3	588049701	Decal Fender 100 DB/CE
4	586207302	Decal Sideskirt LH
5	581579801	Decal Warning
6	581579701	Decal Warning Engine Symbols
7	581579601	Decal Chassis Hot Muffler
8	581578101	Decal Fender Warn
9	581724001	Decal Brake/Clutch Symbols
10	581578001	Decal Saddle Brake Parking
11	439525	Decal Ins Strg Whl
12	584904601	Decal, Deflect. Warning
13	581579201	Decal Deflect. Warn. Cutfng. Sym.

KEY NO.	PART NO.	DESCRIPTION
14	581580003	Decal V-Belt Schematic
20	145005	Decal Bat Dan/Psn
21	421534	Decal V-Belt Sch.
--	581724601	Decal Drawbar Load Limit
--	581724801	Decal Bypass
--	193226X428	Pad Footrest LH
--	193227X428	Pad Footrest RH
--	588096040	Manual Operator's (Euro)
--	588096050	Manual Operator's (Scand)
--	588096020	Manual Operator's (Ebloc)
--	588096030	Manual Operator's (Baltic)
--	588096026	Manual Parts

## WHEELS & TIRES

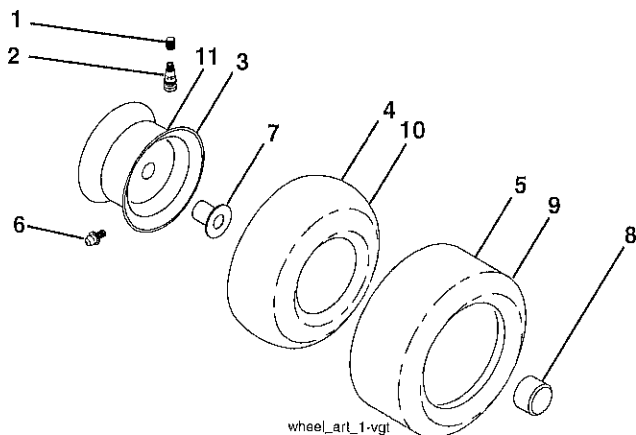

wheel\_art\_1-vgt

KEY NO.	PART NO.	DESCRIPTION
1	59192	Cap Valve Tire
2	65139	Stem Valve
3	106732X613	Rim Asm 6" Front
4	59904	Tube Front (Service Item Only)
5	106222X	Tire Front 15 x 6-6
6	278H	Fitting Grease (Front Wheel Only)
7	9040H	Bearing Flange (Front Wheel Only)
8	104757X428	Cap Axle Blk 1 50 x 1 00
9	420531	Tire Rear 18 x 9.5-8
10	7152J	Tube Rear (Service Item Only)
11	106108X613	Rim Asm 8" Rear Service
--	144334	Sealant, Tire (10 oz. Tube)

**NOTE:** All component dimensions given in U.S. inches  
1 inch = 25.4 mm

---

# SERVICE NOTES

---

TRACTOR - - MODEL NUMBER 917.990380

HYDRO GEAR - MODEL NUMBER T2-CDBE-5X1A-18C1

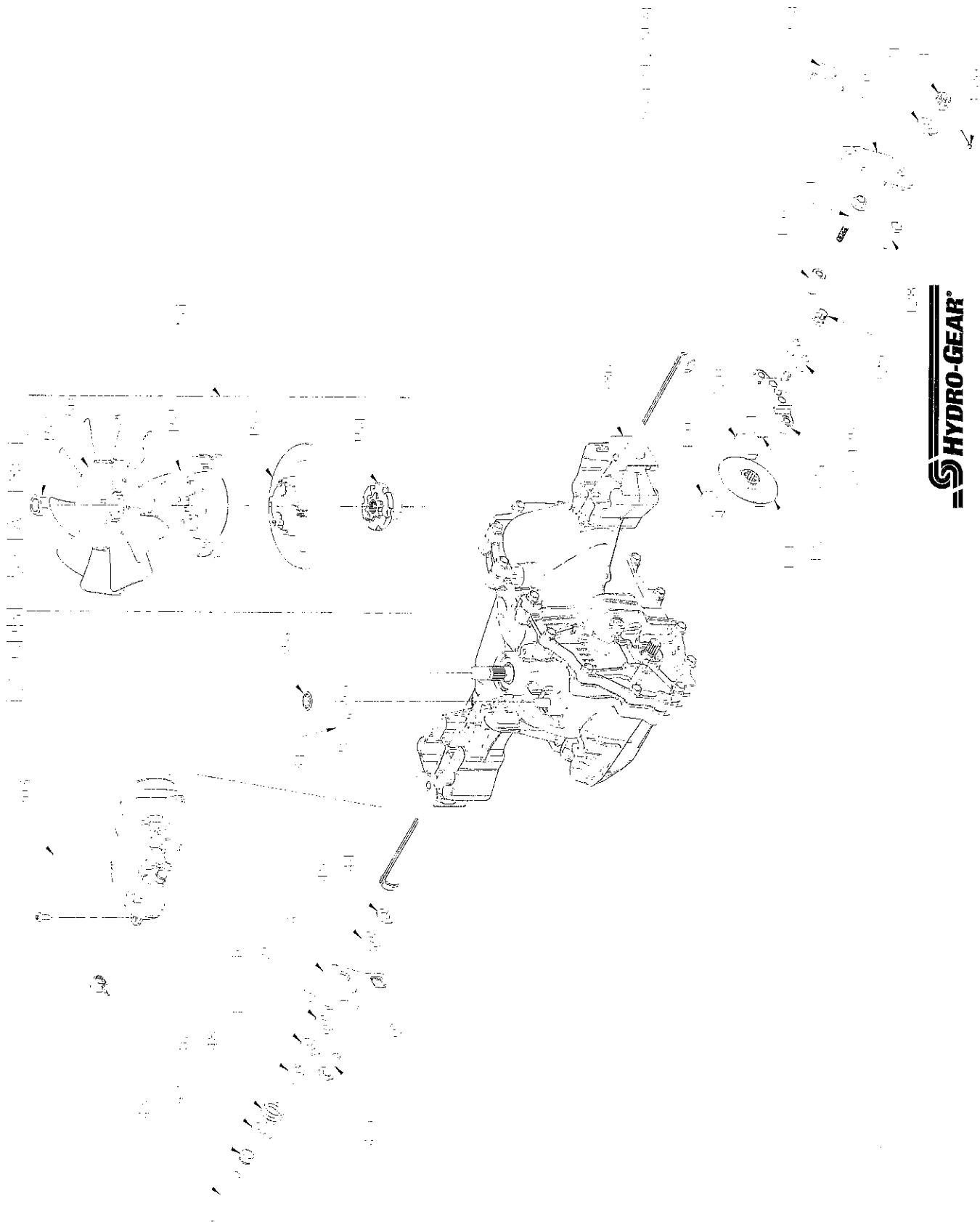

**TRACTOR - - MODEL NUMBER 917.990380****HYDRO GEAR - MODEL NUMBER T2-CDBE-5X1A-18C1**

<b>KEY NO.</b>	<b>PART NO.</b>	<b>DESCRIPTION</b>
34	584280701	Arm Bypass
35	584281001	Ring, Ret .375 Ext
41	584281201	Screw 5/16-18X1
42	584289801	Arm Control
43	584281301	Screw Set 5/16-24X2.50
44	584283301	Washer Belleville
45	584283101	Washer Plastic.32X.80X.21
46	584283001	Washer.34X.88X.06
47	584282801	Spacer .32X.59X.50
48	584282701	Spring Helical Comp
49	584289501	Nut,Hex 5/16-24 Nylon Insert
120	584282601	Puck.Brake
121	584282501	Rotor.Brake
122	584289601	Plate.Puck
124	584289701	Yoke.Brake
125	584287501	Pin.Brake.31X.73 Plated
126	584282401	Spacer.26X.57X.87
127	584281401	Screw ¼-20X2.0 W/Patch
128	584281501	Screw ¼-20X1 Patch
129	584282201	Spring, Comp Brake Anti Drag
130	584282301	Arm.Brake
131	584287401	Washer .34X.88X.06
132	584281701	Nut.Castle 5/16-24 PI
133	584286601	Pin.Cotter 3/32X3/4
134	584281901	Spring Brake Arm Bias
150	584282001	Fan 7", 10 Blade
151	584286101	Pulley 4.0
152	584282101	Nut,Hex Ja ½-20 W Patch
153	584287201	Flange Pulley 4.895
154	584287301	Hub Pulley
180	584281601	Spring,Clip Housing Thrust
203	584285201	Kit,E-Tank
204	584285002	Kit,Fan & Pulley
205	584285001	Kit, Seal

**NOTE:** All component dimensions give in U.S. inches  
1 inch = 25.4 mm

# TRACTOR- -MODEL NO. 917.990380

## BRIGGS & STRATTON ENGINE - - MODEL NUMBER 31R777, TYPE NUMBER 0003-B1

48 SHORT BLOCK

1036 EMISSIONS LABEL

1058 OPERATOR'S MANUAL

1329 REPLACEMENT ENGINE

1330 REPAIR MANUAL

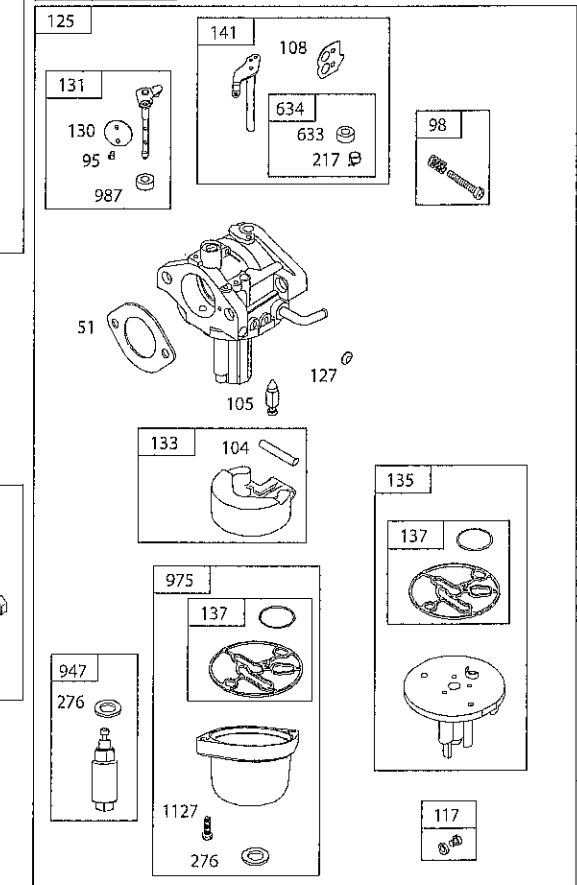
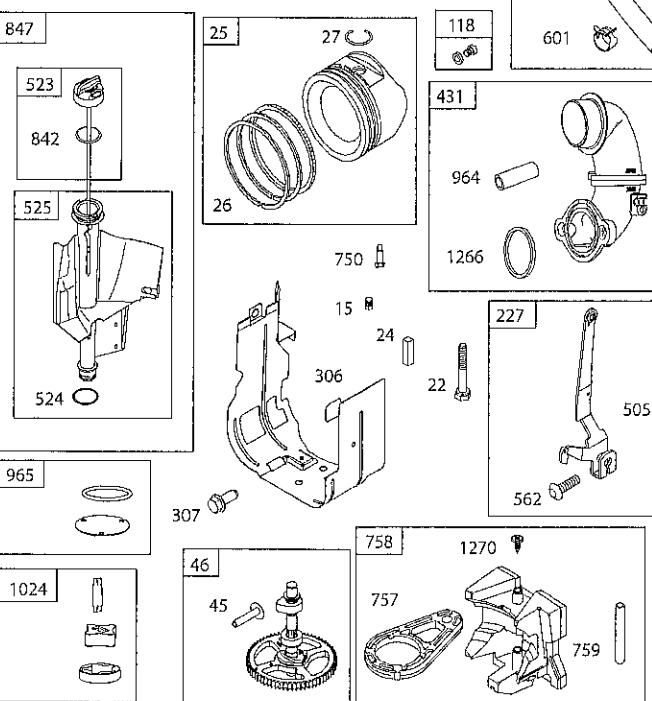
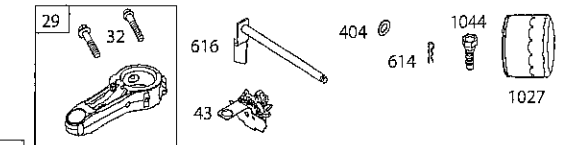
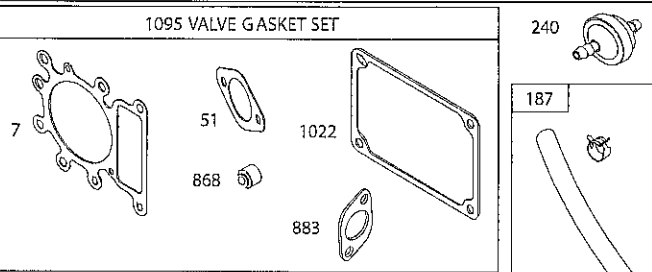
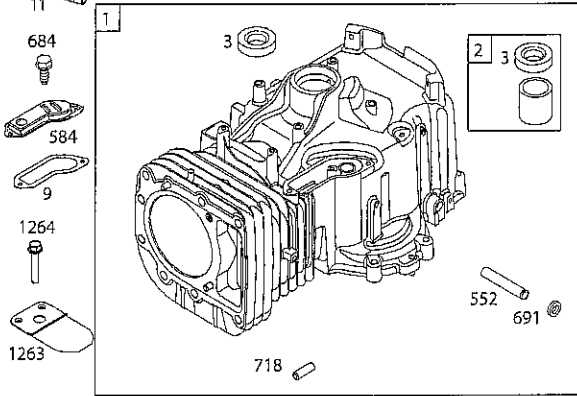
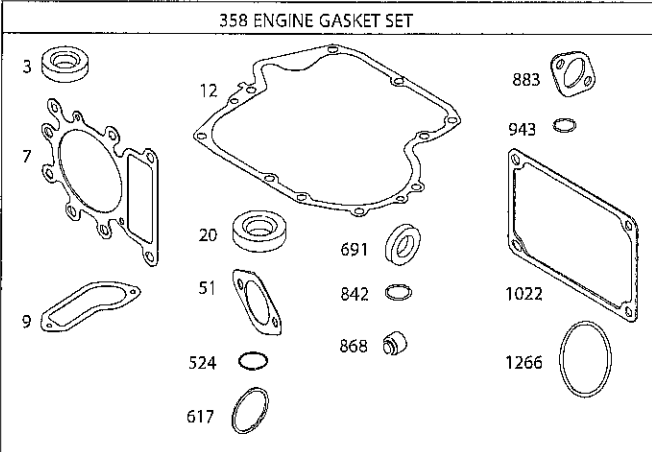
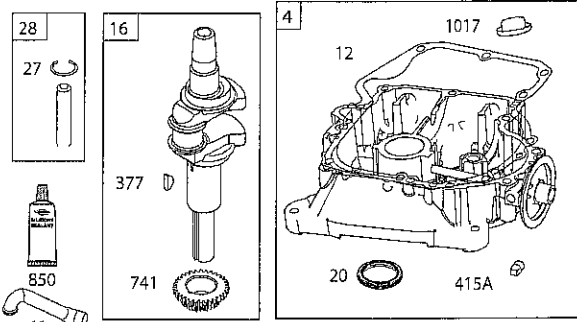
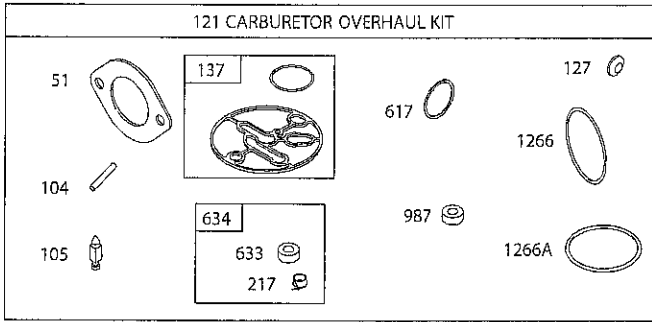

**TRACTOR- -MODEL NO. 917.990380**  
**BRIGGS & STRATTON ENGINE - - MODEL NUMBER 31R777, TYPE NUMBER 0003-B1**

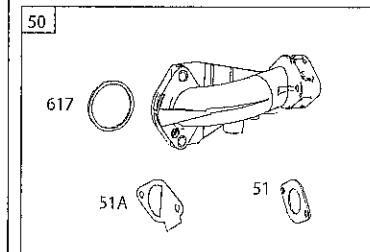
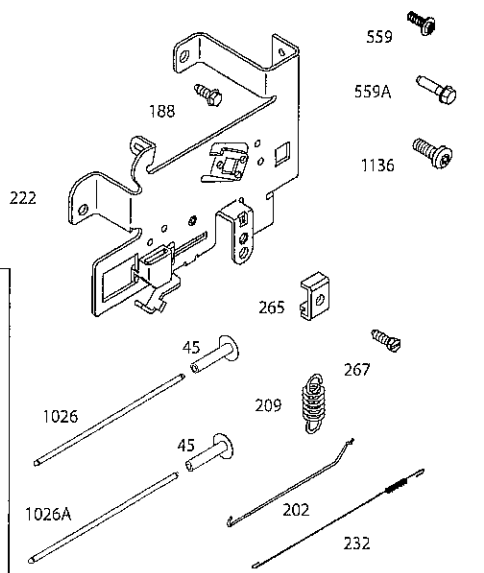
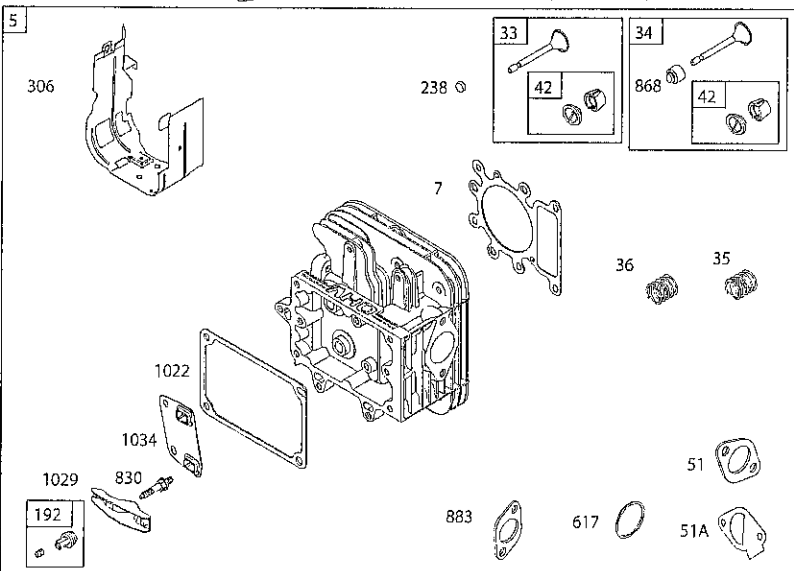
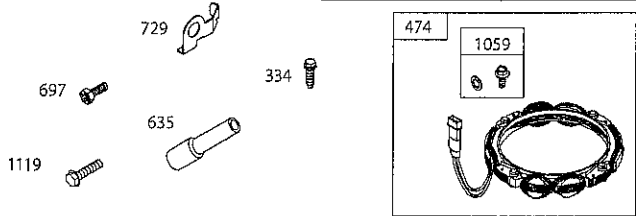
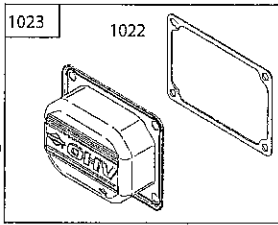
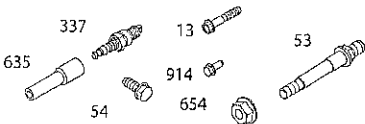
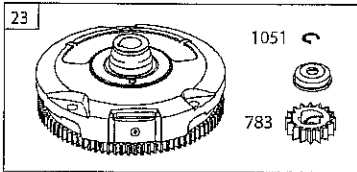
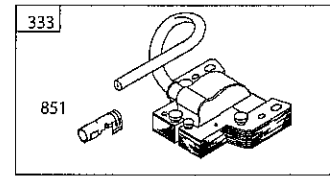
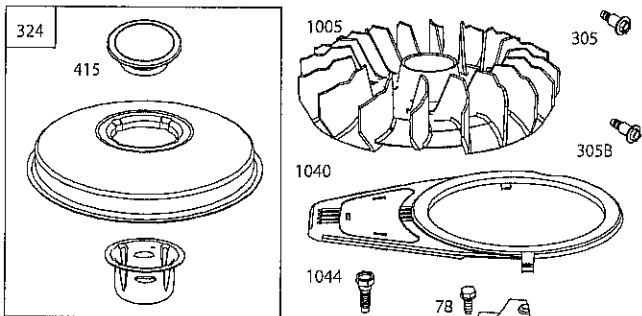
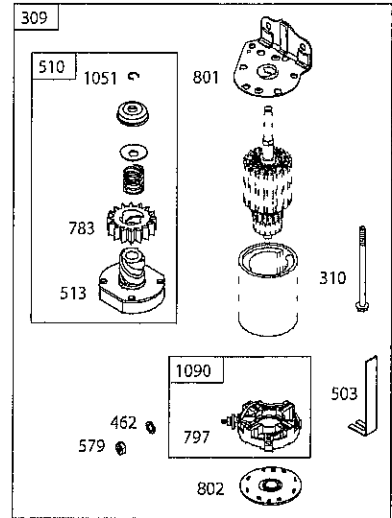
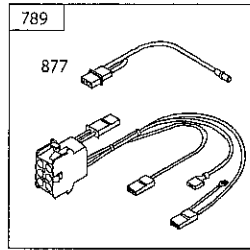
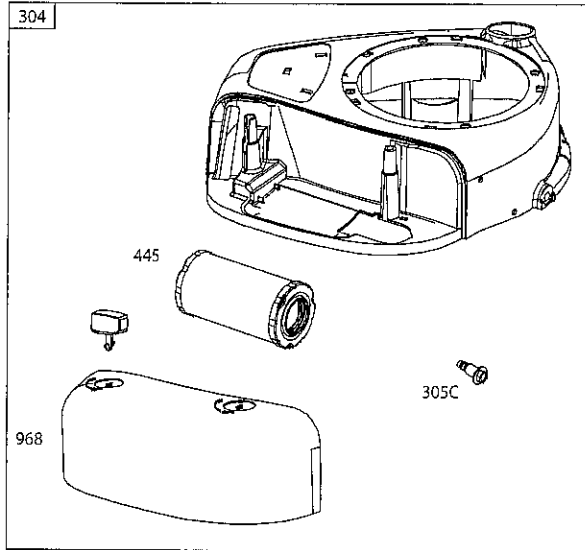

**TRACTOR- -MODEL NO. 917.990380**  
**BRIGGS & STRATTON ENGINE - - MODEL NUMBER 31R777, TYPE NUMBER 0003-B1**

KEY NO.	PART NO.	DESCRIPTION	KEY NO.	PART NO.	DESCRIPTION
1	796010	Cylinder Assembly	137	698781	Gasket-Float Bowl
2	797673	Bushing/Seal Kit (Magneto Side)	141	592937	Kit-Choke Shaft
3	391086s	Seal-Oil (Magneto Side)	187	791766	Line-Fuel (Cut to Required Length)
4	592849	Sump-Engine	188	691693	Screw (Control Bracket)
5	796026	Head-Cylinder	192	691986	Adjuster-Rocker Arm
7	796584	Gasket-Cylinder Head	202	691841	Link-Mechanical Governor
9	697109	Gasket-Breather	209	796260	Spring-Governor (Green)
11	794683	Tube-Breather	217	695409	Spring-Choke Return
12	697110	Gasket-Crankcase	222	694042	Bracket-Control
13	592244	Screw (Cylinder Head)	227	691374	Lever-Governor Control
15	690946	Plug-Oil Drain	232	691842	Spring-Governor Link
16	591762	Crankshaft	238	691843	Cap-Valve
20	795387	Seal-Oil (PTO Side)	240	394358s	Filter-Fuel
22	692125	Screw (Crankcase Cover/Sump)	265	691024	Clamp-Casing
23	591759	Flywheel	267	794904	Screw (Casing Clamp)
24	591757	Key-Flywheel (Steel)	276	695410	Washer-Sealing
25	796172	Piston Assembly (Standard)	304	591642	Blower Housing
	796173	Piston Assembly (.020" Oversize)	305	697102	Screw (Blower Housing)
26	791936	Ring Set (Standard)			(1/4-20x1.21)
	792649	Ring Set (.020" Oversize)	305B	795891	Screw (Blower Housing)
27	698469	Lock-Piston Pin			(#10-16x.43)
28	796007	Pin-Piston	305C	799370	Screw (Blower Housing)
29	794122	Rod-Connecting			(1/4-20x.90)
32	791118	Screw (Connecting Rod)	306	592777	Shield-Cylinder
33	792868	Valve-Exhaust	307	691693	Screw (Cylinder Shield)
34	791935	Valve-Intake	309	693551	Motor-Starter
35	691279	Spring-Valve (Intake)	310	690323	Screw (Starter Motor)
36	691279	Spring-Valve (Exhaust)	324	796308	Screen/Cup Assembly
37	697352	Guard-Flywheel	333	592841	Armature-Magneto
42	499586	Keeper-Valve	334	691061	Screw (Magneto Armature)
43	691968	Slinger-Governor/Oil	337	792015	Plug-Spark
45	690564	Tappet-Valve	358	796187	Gasket Set-Engine
46	793880	Gear-Cam	377	691639	Key-Woodruff
48	N/A	Short Block (Not Available at This Printing)	404	691691	Washer (Governor Crank)
			415	794129	Plug (Cover/Retainer)
50	592842	Manifold-Intake	415A	794903	Plug
51	692137	Gasket-Intake	431	797901	Elbow-Intake
51A	796081	Gasket-Intake	445	591334	Filter-Air Cleaner Cartridge
53	591260	Stud (Carburetor)	462	691261	Washer (Starter Cable)
54	691148	Screw (Intake Manifold)	474	592831	Alternator
78	691693	Screw (Flywheel Guard)	503	691532	Strap-Starter
95	690718	Screw (Throttle Valve)	505	691251	Nut (Governor Control Lever)
98	695408	Kit-Idle Speed	510	693699	Drive-Starter
104	694918	Pin-Float Hinge	513	692024	Clutch-Drive
105	696136	Valve-Float Needle	523	699908	Dipstick
108	695419	Valve-Choke	524	691032	Seal-Dipstick Tube
117	699457	Jet-Main (Standard)	525	697184	Tube-Dipstick
118	695415	Jet-Main (High Altitude) (5000/9000 Feet)	552	697144	Bushing-Governor Crank
			559	693675	Screw (Remote Choke Stop)
121	796184	Kit-Carburetor Overhaul			(6 Lobe)
125	591731	Carburetor	559A	697561	Screw (Remote Choke Stop)
127	690727	Plug-Welch			(#8-32x.37)
130	699500	Valve-Throttle	562	691119	Screw (Governor Control Lever)
131	699501	Kit-Throttle Shaft	579	691029	Nut (Starter Cable)
133	694914	Float-Carburetor	584	794682	Cover-Breather Passage
135	698780	Tube-Fuel Transfer	601	791850	Hose-Clamp (Green)





---

# SERVICE NOTES

---

---

# SERVICE NOTES

---

### LIMITED WARRANTY ON CRAFTSMAN RIDING EQUIPMENT

For two (2) years from the date of purchase, if this Craftsman Riding Equipment is maintained, lubricated and tuned up according to the instructions in the owner's manual, Sears will repair or replace free of charge any parts that are found to be defective in material or workmanship according to the guidelines of coverage listed below. Sears will also provide free labor for these applicable warranted parts for the two full years. During the first 30 days of purchase, there will be no charges to service the product at your home for issues covered by this warranty. (See exclusions below). For your convenience, IN HOME warranty service will still be available after the first 30 days of purchase, but a trip charge will apply. This charge will be waived if the Craftsman product is dropped off at an authorized Sears location. For the nearest authorized Sears location, please call 1-800-4-MY-HOME®. This warranty applies only while this product is within the United States.

This Warranty does not cover:

- Expendable items which become worn during normal use, including but not limited to blades, spark plugs, air cleaners, belts, and oil filters.
- Standard Maintenance Servicing, oil changes, or tune-ups
- Tire replacement or repair caused by punctures from outside objects, such as nails, thorns, stumps, or glass.
- Repairs necessary because of operator abuse, including but not limited to, damage caused by towing objects beyond the capability of the riding equipment, impacting objects that bend the frame or crankshaft, or over-speeding the engine.
- Repairs necessary because of operator negligence, including but not limited to, electrical and mechanical damage caused by improper storage, failure to use the proper grade and amount of engine oil, failure to keep the deck clear of flammable debris, or failure to maintain the equipment according to the instructions contained in the owner's manual.
- Engine (fuel system) cleaning or repairs caused by fuel determined to be contaminated or oxidized (stale). In general, fuel should be used within 30 days of its purchase date.
- Normal deterioration and wear of the exterior finishes, or product label replacement.
- Riding equipment used for commercial or rental purposes.

### LIMITED WARRANTY ON BATTERY

For ninety (90) days from date of purchase, if any battery included with this riding equipment proves defective in material or workmanship and our testing determines the battery will not hold a charge, Sears will replace the battery at no charge. During the first 30 days of purchase, there will be no charges to replace the battery at your HOME. After the first 30 days, for your convenience, IN-HOME warranty service will still be available but a trip charge will apply. This charge will be waived if the Craftsman product is dropped off at an authorized Sears location. For the nearest authorized Sears location, please call 1-800-4-MY-HOME®.

This battery warranty applies only while this product is within the United States.

This warranty gives you specific legal rights, and you may also have other rights, which vary, from state to state.

Sears Brands Management Corporation, Dept.817WA, Hoffman Estates, IL 60179

